



(51) International Patent Classification:

A61B 5/00 (2006.01) A61N 1/39 (2006.01)  
A41D 1/00 (2006.01) H04W 4/22 (2009.01)

(21) International Application Number:

PCT/IL2014/050895

(22) International Filing Date:

12 October 2014 (12.10.2014)

(25) Filing Language:

English

(26) Publication Language:

English

(30) Priority Data:

61/892,475 18 October 2013 (18.10.2013) US

(71) Applicant: **HEALTHWATCH LTD.** [IL/IL]; 34 Hazeitim Street, 4630734 Herzliya (IL).

(72) Inventors: **ROMEM, Yoram**; 34 Hazeitim Street, 4630734 Herzliya (IL). **AMIR, Uri**; 6 Almog Street, 60405 Or Yehuda (IL).

(74) Agent: **KATZ, Itzhak**; 7 Haim Gilad Street, 4937754 Petach Tikva (IL).

(81) Designated States (unless otherwise indicated, for every kind of national protection available): AE, AG, AL, AM, AO, AT, AU, AZ, BA, BB, BG, BH, BN, BR, BW, BY, BZ, CA, CH, CL, CN, CO, CR, CU, CZ, DE, DK, DM,

DO, DZ, EC, EE, EG, ES, FI, GB, GD, GE, GH, GM, GT, HN, HR, HU, ID, IL, IN, IR, IS, JP, KE, KG, KN, KP, KR, KZ, LA, LC, LK, LR, LS, LU, LY, MA, MD, ME, MG, MK, MN, MW, MX, MY, MZ, NA, NG, NI, NO, NZ, OM, PA, PE, PG, PH, PL, PT, QA, RO, RS, RU, RW, SA, SC, SD, SE, SG, SK, SL, SM, ST, SV, SY, TH, TJ, TM, TN, TR, TT, TZ, UA, UG, US, UZ, VC, VN, ZA, ZM, ZW.

(84) Designated States (unless otherwise indicated, for every kind of regional protection available): ARIPO (BW, GH, GM, KE, LR, LS, MW, MZ, NA, RW, SD, SL, ST, SZ, TZ, UG, ZM, ZW), Eurasian (AM, AZ, BY, KG, KZ, RU, TJ, TM), European (AL, AT, BE, BG, CH, CY, CZ, DE, DK, EE, ES, FI, FR, GB, GR, HR, HU, IE, IS, IT, LT, LU, LV, MC, MK, MT, NL, NO, PL, PT, RO, RS, SE, SI, SK, SM, TR), OAPI (BF, BJ, CF, CG, CI, CM, GA, GN, GQ, GW, KM, ML, MR, NE, SN, TD, TG).

Declarations under Rule 4.17:

— of inventorship (Rule 4.17(iv))

Published:

— with international search report (Art. 21(3))  
— before the expiration of the time limit for amending the claims and to be republished in the event of receipt of amendments (Rule 48.2(h))

(54) Title: INDEPENDENT WEARABLE HEALTH MONITORING SYSTEM, ADAPTED TO INTERFACE WITH A TREATMENT DEVICE

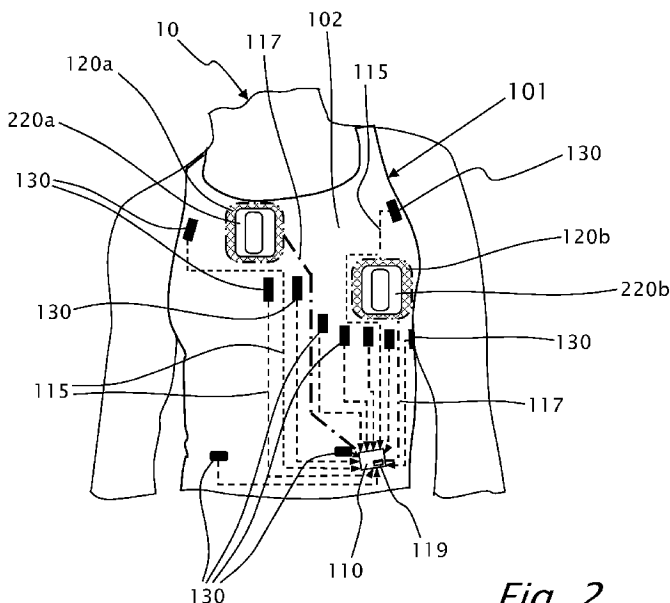

Fig. 2

(57) Abstract: An independent wearable health monitoring system, configured for use by a living being on a daily basis. The system includes a knitted garment worn by the living being adjacently to preconfigured body locations, a garment-processing device having processor, and a multiplicity of sensors adapted to measure health parameters, wherein at least some sensors are integrally knitted with the knitted garment, and wherein the knitted textile sensors include electrodes adapted to provide ECG data. The system further includes an interface adapted to operatively connect at least one external medical device to the garment-processing device. Preferably, the health monitoring system further includes two conductive, integrally knitted pads operatively disposed tightly adjacently to the skin of the monitored living being, adapted to facilitate placing of a respective defibrillator paddles thereon and applying defibrillator shocks. Preferably, the garment-processing device controls the activation and deactivation of the defibrillator shocks.

WO 2015/056262 A1

INDEPENDENT WEARABLE HEALTH MONITORING SYSTEM, ADAPTED TO  
INTERFACE WITH A TREATMENT DEVICE

CROSS REFERENCE TO RELATED APPLICATIONS

5           This application claims the benefit under 35 USC 119(e) from US provisional application 61/892,475 filed Oct 18<sup>th</sup>, 2013, the disclosure of which is included herein by reference.

          This application also relates to PCT applications PCT/IL2010/000774 ('774), PCT/IL2012/000248 ('248), PCT/IL2013/050964 ('964) and PCT/IL2014/050134  
10 ('134), the disclosures of which are included herein by reference in their entirety.

FIELD OF THE INVENTION

          The present invention relates to real-time health monitoring systems and more particularly, the present invention relates to an independent wearable, substantially  
15 continuous health monitoring system, carried by a monitored person (or another living being) by wearing special garments having textile electrodes knitted therein, such that the system does not interfere with the everyday life of the monitored living being. The system is adapted to plug-in external medical and other devices, such as a defibrillator, a team-tracker (sport, games, first-responders etc.) or an ergometer, that utilize ECG data  
20 or any other relevant system data such as blood pressure, oxygen saturation, breathing, temperature, dehydration, impedance and data obtained from any other sensors (and may be processed) that are in operative communicating with the controlling unit of the system.

          Furthermore, the system of the present invention issues a personal-alert to the  
25 monitored person, and possibly to external parties, upon detecting a potentially health hazardous situation. The monitored person does not need to do anything in order to get a personal-alert, but just to wear the special garments (including an undershirt or a bra) that are part of the system and to have a smart device, such as his/her personal smart-phone, nearby, thus facilitating the detection of a variety of health related abnormalities,  
30 including the main aspects of cardiac hazards such as Arrhythmia, Ischemia, heart failure and more.

## BACKGROUND OF THE INVENTION AND PRIOR ART

PCT application '774 explains the need for “a health monitoring system, implantable into and/or wearable by a living being to be monitored, wherein the system does not interfere with the everyday life of the monitored living being and issues an alert  
5 upon detecting a potentially health hazardous situation or a tendency to develop such situation.” Such an “early warning” system, is the basis of the current invention.

As described in '774, there is a need for a health monitoring system that continuously checks the well being of a person (or any other living being) that, typically, is considered healthy, or a person with a known set of diseases or a person in a specific  
10 risk group, covering a significant range of health hazards that may cause a significant life style change/limitation, and provides an alert as early as possible – all this, with no significant limitation to the normal life style of the person bearing the system. Naturally, such a system may also be used by a sick person, detecting potential exacerbations or new problems.

15 PCT application '964 describes a garment, having built-in sensors and electrodes, adapted to provide clinical level ECG, providing a 15-leads ECG, as well as measuring other health parameters.

There are other medical devices and systems that require heart parameters measurement to operate and that may take advantage of the clinical level ECG provided  
20 by the garment described in PCT application '964, for example a defibrillator.

In the case of a defibrillator, there is a need, in regular operation, to attach two paddles or pads to the chest of the person. This operation takes some critical time and needs to be performed by an experienced operator. Furthermore, the defibrillator usually needs to verify that the person is suitable to receive this treatment, by measuring ECG  
25 and determining whether the person has persistent ventricular fibrillation, a systole or consistence atrial fibrillation. This process, again, consumes critical time in the interval before being able to perform the actual defibrillation.

There is therefore a need and it would be advantageous to have an interface built into the garment described in PCT application '964, thereby adapting the garment to  
30 provide the data needed for the specific device or system interfacing into the garment. This will save critical time before the defibrillation.

There is also a need, and it would be advantageous to have built-in pads or paddles in the garment, to save additional critical time in their placement before the defibrillation.

In other cases, being able to track the person, including the motion/posture and the data from other sensors embedded or attached to the garment provides advantage in the gaming, exercising or emergency management.

The term “continuous monitoring”, as used herein with conjunction with a health monitoring system, refers to a health monitoring system, facilitated to monitor a living being substantially continuous, day and night, when the monitored living being is awake or asleep, and active in substantially all common activities of such living being.

The term “seamless”, as used herein with conjunction with a wearable device, refers to a device that when worn by an average person, wherein the device puts no significant limitation to the normal life style of that person and preferably not seen by anybody when used and not disturbingly felt by the user while wearing it. Furthermore, no activity is required from the monitored person in order for the system to provide a personal-alert when needed. It should be noted that people that pursue non-common life style, such as soldiers in combat zone or in combat training zone, or firefighters in training and action, or athletes in training or competition may utilize non-seamless devices. As the "seamless" characteristics refers also to the user's behavior, the wearable component is preferably an item that is normally worn (e.g., underwear) and not some additional item to be worn just for getting the alert.

The terms “underwear” or "garment", as used herein with conjunction with wearable clothing items, refers to seamless wearable clothing items that preferably, can be tightly worn adjacently to the body of a monitored living being, typically adjacently to the skin, including undershirts, brassiere, underpants, socks and the like. Typically, the terms “underwear” or "garment" refer to a clothing item that is worn adjacently to the external surface of the user's body, under external clothing or as the only clothing, in such way that the fact that there are sensors embedded therein and/or integrated therein, is not seen by any other person in regular daily behavior. An underwear item may also include a clothing item that is not underwear per se, but still is in direct and preferably tight contact with the skin, such as a T-shirt, sleeveless or sleeved shirts, sport-bra, tights, dancing-wear, and pants. The sensors, in such a case, can be embedded in such a way that are still unseen by external people to comply with the "seamless" requirement.

The term "tightly" means that specific portions of the garment where there are electrodes or other sensors that require certain pressure on the body to obtain a satisfactory signal, are designed to be as tight as needed. However, all the other parts of the garment may be not as tight. Optionally, there is a provision to facilitate tightening or releasing certain portions of the garment, by built-in straps or other tightening means, so that the need for more or less tightness does not require the replacement of the whole garment.

The term "independent" as used herein with conjunction with a garment, having a wearable device or a health monitoring system, refers to an item that does not depend on any external entity, such as remote monitoring center, but may operationally depend on another regular common personal item of the same user, such as a personal mobile device having a garment-processing application, being part of the health monitoring system. It should be noted that if the monitored living being is not a human being, the personal mobile device is carried by the care-taker of the monitored living being. It should be noted that in the case of an animal, the seamless feature is of lesser importance.

The term "abnormal", as used herein with conjunction with health related parameters, refers to a parameter value or one or more ranges of values which are defined as health hazardous or as potential health hazardous, when a trend is identified, and requires attention. For example, the normal blood pressure of an adult person is in the range 120/80 mm Hg. Typically, a systolic blood pressure of 130 mm Hg would not be considered hazardous. However, if a person has a stable mean blood pressure of around  $85 \pm 10$  mm Hg, and suddenly it increases to  $125 \pm 10$  mm Hg, this may be considered as an abnormal situation. Likewise, if the mean blood pressure changes gradually and consistently from 85 mm Hg to 120 mm Hg, in a clear trend, a personal-alert should be issued. The threshold value from which the high blood pressure parameter is considered as health hazardous may vary and can be set personally and optionally, dynamically updated, either manually or automatically, by an adaptation algorithm. Once the high blood pressure parameter, in the above example, is set, any value out of the set threshold value will then be considered as abnormal for that person.

The phrase "clinical level ECG", as used herein with conjunction with ECG measurements, refers to the professionally acceptable number of leads, sensitivity and specificity needed for a definite conclusion by most cardiology physicians to suspect a

risky cardiac problem (for example, arrhythmia, myocardial ischemia, heart failure) that require immediate further investigation or intervention. Clinical level ECG is derived from a pre-configured number of ECG leads, typically, with no limitations 12 and up to 15-leads ECG, and further preferably coupled with a motion/posture compensation  
5 element, and a real-time processor with adequate algorithms.

The term "personal-alert", as used herein, is a notification issued to the specific user or a designated person (e.g., a person responsible to perform medical intervention in emergency situations or perform the defibrillation), after detecting a health risk hazard by a system according to the present invention. The personal-alert issued by the system  
10 is substantially similar to a decision of a family doctor or another professional physician who would have taken, seeing the abnormal measured parameters, in order to instruct further investigation or intervention. The term "specific user" as used herein, means that the personal-alert decision is preferably made while taking into consideration the history of indications, treatments and personal situation of the user, including personal  
15 preferences and other personally adapted considerations.

A number of systems that analyze a cardiac patient's condition are commonly used. Such systems include some form of ECG electrodes ("probes") that are removably attached adjacent to the patient's body and are connected to the system. Typically, the electrodes are securely attached to the patient's body at a selected location by suction  
20 cups, pads having two-sided glue and other attaching means that can be securely attached to the patient's body and forcedly removed when the measurements are concluded. Thereby, the electrode remains attached to the patient's body at a specific location during the time of measurement, which time is very limited and typically lasts a few minutes up to a few hours.

25 Also, typically, either a physician or a nurse is responsible for the actual placement of the electrodes at the specific points known to be adequate for accurate ECG measurements.

However, when using a wearable, continuous real-time health monitoring system, worn by a monitored person thereby placing the probes just by wearing, a sensor  
30 that is built into garment remains in the vicinity of a specific target bodily location of the monitored person. However, still, there are some changes in the relative position of the sensor with respect to a specific bodily target location of the monitored patient, due to

relative movements of the garment, carrying the sensor, with respect to the body of the monitored patient, or due to the other reasons.

There is therefore an additional need to ensure a reliable sensed signal from a probe, integrated into a garment, requiring at least some compensation for both an initial  
5 misplacement and physical activity displacement.

It should be noted that such a mechanism can be useful in any system with sensors and probes that may move away from their optimal location, thus degrading the quality of their measurement.

It should be further noted that there are several levels of alerts, and several levels  
10 require some operation of interfaced devices, such as, with no limitations, activation and deactivation of a defibrillator.

#### BRIEF SUMMARY OF THE INVENTION

The principal intentions of the present invention include providing a health-  
15 monitoring and self-alert system, including a smart garment adapted to issues a personal-alert to the monitored person wearing the garment (and possibly to external parties), upon detecting a potentially health hazardous situation, including a cardiac related health hazardous situation. The monitored person does not need to do anything in order to get a personal-alert, but just to wear the smart garment (including an undershirt or a bra) that  
20 are part of the system, and to have a smart device, such as his/her personal smart-phone, nearby. A variety of sensors are embedded and/or integrated into the smart garment, thus enabling the detection of a variety of health related abnormalities, including the main aspects of cardiac hazards such as Arrhythmia, Ischemia, heart failure and more. The sensors include textile electrodes for measuring clinical level ECG, providing up to  
25 (with no limitations) 15-leads ECG.

The system of the present invention is adapted to measure health related physiological bodily parameters, including (with no limitations) measuring preferably clinical level ECG, analyzing the data in real-time, and upon detecting a situation which requires further investigation or immediate intervention, alarms the system carrier to  
30 seek medical help. Furthermore, the wearable system includes an interface adapted to operatively connect to one or more external medical systems or devices, such as, with no

limitations, a defibrillator, and to provide required data and analysis such as persistent ventricular fibrillation or ventricular tachycardia indications.

The present invention will be described in terms of the external interfacing device being a defibrillator, but the present invention is not limited to interfacing to a defibrillator, wherein the external interfacing device or system can be any device/system that needs the ECG data to operate properly, for example an ergometer.

According to the teachings of the present invention, there is provided an independent wearable health monitoring system, configured for use by a living being on a daily basis, including a healthy living being. The system includes a knitted garment worn by the living being adjacently to preconfigured portions of the body of the living being, a garment-processing device and a multiplicity of sensors adapted to measure health parameters, wherein at least a portion of the sensors are integrally knitted with the knitted garment, and wherein the knitted textile sensors include electrodes or probe-devices adapted to provide ECG data. The system further includes an interface adapted to operatively connect at least one external medical device to the garment-processing device. The garment-processing device includes a garment-processor and a power sources such as a battery.

The garment-processing device is adapted to acquire the ECG data from the sensors and analyze the ECG data, and upon detecting at least one predefined abnormality in the ECG data, activating at least one pre-selected the external medical device configured to cope with the detected abnormality.

Optionally, the health monitoring system further includes an alerting unit, wherein the garment-processing device, upon detecting at least one predefined abnormality in the ECG data, activates the alerting unit. Optionally, the ECG data in a clinical level ECG data.

Optionally, the sensors include sensors for sensing blood pressure, oxygen saturation, breathing, temperature, dehydration, impedance, sweat analysis, lung fluids and heart rate.

Optionally, the health monitoring system is seamless self-alert system.

In some embodiments, the health monitoring system further includes at least one conductive knitted pad operatively disposed tightly adjacently to the skin of the monitored living being, wherein the at least one conductive knitted pad is adapted to

facilitate placing of a respective defibrillator paddle thereon and applying defibrillator shocks. Preferably, the garment-processing device is operatively connected to an apparatus controlling the at least one defibrillator paddle, and wherein the garment-processing device controls the activation and deactivation of the defibrillator shocks.

5 Optionally, the at least one defibrillator paddle is manually activated and deactivated.

Optionally, the knitted garment has a tubular form having variable elasticity, and wherein the at least one conductive knitted pad is operatively disposed tightly adjacently to the skin of the monitored living being.

Optionally, the garment-processing device further includes protecting means to  
10 protect the garment-processing device from the current surge inflicted by the defibrillator onto the at least one conductive knitted pad.

#### BRIEF DESCRIPTION OF THE DRAWINGS

The present invention will become fully understood from the detailed description  
15 given herein below and the accompanying drawings, which are given by way of illustration and example only and thus not limitative of the present invention:

Fig. 1 (prior art) schematically illustrates a seamless independent wearable health monitoring and self-alert system, including a knitted garment-body being an undershirt, interconnected sensors/electrodes by conductive yarns, a garment-processing device and  
20 a mobile device having a remote-processor, as described PCT application '964.

Fig. 2 is a schematic illustration of the undershirt shown in Fig. 1, adapted to operatively interface with an external device, for example a defibrillator, according to embodiments of the present invention, wherein the defibrillator paddles are placed over respective textile pads integrally knitted into the undershirt.

25 Fig. 3a is a schematic illustration the undershirt shown in Fig. 2, having the defibrillator paddles removed.

Fig. 3b is a detailed view illustration of window A, shown in Fig. 3a.

Fig. 4a depicts a front view of an exemplary garment of the schematic system shown in Fig. 3a, wherein the textile electrodes are designed to measure a 15-lead ECG signal.

30 Fig. 4b depicts a side view of the garment shown in Fig. 4a.

## DETAILED DESCRIPTION OF THE INVENTION

The present invention will now be described more fully hereinafter with reference to the accompanying drawings, in which preferred embodiments of the invention are shown. This invention may, however, be embodied in many different  
5 forms and should not be construed as limited to the embodiments set forth herein; rather, these embodiments are provided, so that this disclosure will be thorough and complete, and will fully convey the scope of the invention to those skilled in the art.

An embodiment is an example or implementation of the inventions. The various appearances of "one embodiment," "an embodiment" or "some embodiments" do not  
10 necessarily all refer to the same embodiments. Although various features of the invention may be described in the context of a single embodiment, the features may also be provided separately or in any suitable combination. Conversely, although the invention may be described herein in the context of separate embodiments for clarity, the invention may also be implemented in a single embodiment.

Reference in the specification to "one embodiment", "an embodiment", "some  
15 embodiments" or "other embodiments" means that a particular feature, structure, or characteristic described in connection with the embodiments is included in at least one embodiment, but not necessarily all embodiments, of the inventions. It is understood that the phraseology and terminology employed herein is not to be construed as limiting  
20 and are for descriptive purpose only.

Meanings of technical and scientific terms used herein are to be commonly understood as to which the invention belongs, unless otherwise defined. The present invention can be implemented in the testing or practice with methods and materials equivalent or similar to those described herein.

As used herein, the singular form "a", "an" and "the" include plural references  
25 unless the context clearly dictates otherwise. For example, the term "a compound" or "at least one compound" may include a plurality of compounds, including mixtures thereof.

The word "exemplary" is used herein to mean "serving as an example, instance or illustration". Any embodiment described as "exemplary" is not necessarily to be  
30 construed as preferred or advantageous over other embodiments and/or to exclude the incorporation of features from other embodiments.

The word "optionally" is used herein to mean "is provided in some embodiments and not provided in other embodiments". Any particular embodiment of the invention

may include a plurality of “optional” features unless such features conflict.

It should be noted that the present invention will often be described in terms of the knitted monitoring-garment being an undershirt, but the present invention is not limited to an undershirt being the monitoring-garment, and type of garment, at least partially worn adjacently to the body of the monitored living being can be used as a monitoring-garment.

It should be noted that the present invention will be described in terms of the mobile device being a smart-phone, but the present invention is not limited to being a smart-phone, and includes all types of mobile devices having a central processing unit and memory, including a mobile phone, laptop, a PDA, a processing pad, etc., all having Bluetooth or any other wireless communication capabilities. According to the teachings of the present invention, there is provided an independent, seamless and preferably substantially continuous health monitoring system, designed for use by a healthy living being but also suitable for non-healthy living being.

Reference now made to the drawings. Fig. 1 (prior art) schematically illustrates an example seamless, independent, wearable and preferably continuous health monitoring and self-alert system **100** (also referred to herein as "health-monitoring-garment-based system **100**"), including a basic knitted garment **102** having a tubular form, a removable garment-processor **110** and optionally, a mobile device **500**, having a remote-processor **510**. Health-monitoring-garment-based system **100** is a non-limiting, exemplary monitoring-garment item, wherein sensors **130** are operatively with garment-processing device **110**, as schematically illustrated in Fig. 1. Sensors **130** are embedded into the garment-body **102** of monitoring-garment **100**, preferably knitted therein. Preferably, sensors **130** are formed by washable yarn, when the garment is knitted.

Typically, health-monitoring-garment-based system **100** looks like a regular undershirt and preferably, the embedded sensors are adapted to sense physiological bodily parameters, including (with no limitations) measuring cardiac related parameter such ECG . A person **10** can easily wear the undershirt in any situation where he or she is used to. When the undershirt is firstly provided to person **10**, the size and tightness to the person’s body are fitted such that sensors **130** are disposed at the correct bodily regional places and with appropriate contact with the person’s body, tightened to the skin. Tightness is achieved by using preconfigured variable elasticity of knitted garment **102**, as described in ‘134.

Health-monitoring-garment-based system **100** may include a variety of sensors, including optical sensors for sensing the oxygen level in the blood. ECG sensors are for detecting heart-rate (HR) related irregularities (arrhythmia) as well as ischemia (more precisely, placed at the standard ECG positions), facilitated by up to 15-leads ECG (with no limitations). Acoustic sensors are for detecting lung fluids and HR and impedance sensors are for detecting congestive heart failure (CHF). Also, breathing sensors, such as carbon-elastomer stretch or impedance sensors that can detect breathing rhythm and breathing regularity or irregularity. A pressure sensor is an example sensor that measures the in and out motion of the thorax, facilitating detecting breathing and measuring breathing rate. The sensors may further include sweat analysis sensors, temperature and other sensors.

Knitted garment **102** of health-monitoring-garment-based system **100** is preconfigured for wear either by a man or a woman and preferably, comes in a variety of sizes.

Preferably, also embedded into knitted garment **102** are conductive textile wires **115**, connecting the sensors to garment-processor **110**. Optionally, also embedded into knitted garment **102** are wires interconnecting some of the sensors (e.g. between couples of impedance sensors). In some embodiments, conductive textile wires **115** are connected to garment-processor **110** via click-on button interface **111**. In some embodiments, conductive textile wires **115** are connected to garment-processor **110** via an HDMI interface. Such a connecting mechanism is described in US Provisional Patent Applications 61/981,213 filed in Apr 18, 2014 and 62/014,753 filed in June 20, 2014, the disclosures of which are included herein by reference in their entirety.

Reference is now made to Fig. 2, schematically illustrating a health-monitoring-garment-based system **101**, which health-monitoring-garment-based system **101** is similar to health-monitoring-garment-based system **100**, wherein knitted garment **102** may further includes conductive pads **220** integrally knitted into knitted garment **102**. Hosting pads **220**, being operatively disposed tightly adjacently to the skin of person **10**, are adapted for hosting paddles **220** of a defibrillator, wherein hosting pads **220** are connected to garment-processing device **110** by designated conductive wiring **117**, such as conductive yarns, according to embodiments of the present invention. The paddles of a defibrillator may also be attached to knitted garment **102** at selected locations by any other attaching mechanism known in the art. The paddle, however, are connected to

garment-processing device **110** by designated conductive wiring **117**, according to other embodiments of the present invention.

Reference is also made to Fig. 3a, schematically illustrating a health-monitoring-garment-based system **101**, as schematically shown in Fig. 2, wherein the defibrillator paddles **220** are removed from hosting paddles **220**. Fig. 4a depicts a front view of an exemplary garment **101** of the schematic system shown in Fig. 3a, wherein the textile electrodes are designed to measure up to 15-lead ECG signal. Fig. 4b depicts a side view of garment **101** shown in Fig. 4a.

Reference is also made to Fig. 3b, a detailed view illustration of a window **A** shown in Fig. 3a that illustrates health-monitoring-garment-based system **101**, wherein garment-control device **110** further includes an interface **119** adapted to interconnect with an external device **210** or an interface thereof.

Interface **119** is adapted to transfer relevant system data to one or more external medical systems or devices such as a defibrillator, operatively connect to health-monitoring-garment-based system **100** via an interface such as interface **119**. In the case of a defibrillator, health-monitoring-garment-based system **100** provides required data and analysis such as persistent ventricular fibrillation. Optionally, the external device is given permission to control usage of the embedded sensors and other usable devices of health-monitoring-garment-based system **100**. Optionally, interface **119** is physically separated from garment-processing device **110**. In the case of a defibrillator, interface **119** is designed to withstand high electric current surges.

In the case external device **210** is a defibrillator, hosting pads **220** are operatively connected to garment-processing device **110** by designated conductive wiring **117**. Garment-processing device **110** further includes an interface **119** adapted to interconnect with the external defibrillator (or any other external device), wherein external device **210** is operatively connected to the paddles held by hosting pads **220**. Thereby, when garment-processing device **110** determines a pre-determined health related situation that requires activation of the defibrillator paddles, garment-processing device **110** activates external device **210** to thereby activate the paddles via interface **119**. Upon detecting cardiac vitality, garment-processing device **110** deactivates external device **210** to thereby deactivate the paddles.

Alternatively, a preconfigured number of designated textile electrodes, disposed at preconfigured location, about the heart position, may be activated manually by a

medical personal, by connecting directly to the designated textile electrodes.

Since pads **220** and sensors **130** must be in substantially adjacent to the user's skin, pads **220** and the sensors **130** are typically spatially separated on knitted garment **102**. However, since the contact surface of a pad **220** is substantially larger than that of a  
5 sensor **130**, one or more sensors **130** may be disposed in a void formed inside a pad **220**, or may be part of a pad **220**, provided that sensor **130** is immune to high electric surges.

Optionally, the external defibrillator is removably connected to a designated button, similar to button **111**, wherein optionally, the designated button facilitates a click-on connection or removal operations, and wherein the designated button is  
10 operatively connected to the processor of garment-processing device **110**.

In some embodiments of the present invention, garment-processing device **110** analyzes the sensed data obtained by one or more of the sensors **130** to thereby determine if a health hazardous situation has occurred. In such an event, garment-processing device **110** activates an alerting unit, coupled to operate with garment-processing device **110**, to thereby provide a personal-alert to person **10**. The personal-alert  
15 may be in the form of an audio sound, a light indication, any other form known in the art, or a combination thereof.

Garment-processing device **110** may further calculate values, compare thresholds, trends, averages etc., and may provide the calculated data to an external  
20 recipient. Optionally, garment-processing device **110** further includes memory for storing data for calculations, comparisons to past measurements, determining trends, calibration, determining sensors reliability, further remote analysis at external places and for future use (for example, for use in physical exercise consulting).

In some embodiments of the present invention, garment-processing device **110** is  
25 subdivided into multiple, individual processing units, wherein each of the individual processing unit is operatively coupled with one or more sensors.

Optionally, garment-processor **112** does not have an "On/Off" button, but is activated automatically when engaged with button **111**. This eliminates the need of a manual activation by the user, which is a source for errors and inconvenience.

To facilitate clinical level ECG measurements and thereby clinical level  
30 cardiologic ischemia analysis, ECG sensors **130** may be configured as multiple-lead ECG, preferably 12 or 15-leads ECG, as shown in Fig. 1, having additional electrodes on the back (such as at positions V<sub>7</sub>, V<sub>8</sub>) and on the left side of person **10**. For activating a

defibrillator, the only sensors that the health monitoring and self-alert system needs are the multiple-lead ECG (multi-lead ECG), facilitating clinical level ECG measurements and thereby clinical level cardiologic ischemia analysis. The ECG can thus be a 15-leads ECG (for added sensitivity), an 18-lead ECG or any additional number of electrodes that the wearable platform enables. The sensors are embedded in the monitoring-garment so that they are tightened to the skin at a respective preconfigured position, per each sensor's specific functionality (e.g. ECG - standard positions, acoustic - at the basal aspects of the lungs).

The ECG can detect, for example, HR related irregularities as well as ischemia (for example, ST elevation and depression, T-wave inversion and new left bundle branch block). Blood pressure is also indicative of heart or other cardio-vascular problems, as well as body temperature changes.

In some embodiments of the present invention the interface by which interface conductive textile wires **115** are connected to garment-processor **110**, such as an HDMI interface, includes a protecting means to protect garment-processor **110** from the current surge inflicted by the defibrillator. The protecting means may include Zener diodes and or other current surge protecting means such as ZL70584 an eight-terminal IC, for example.

It should be noted that the pads for housing the defibrillator can be part of the wearable garment or external (attached defibrillator connecting to the control unit of the garment including external pads). In this configuration, time is saved in the process of getting all the data needed for the appropriate activation of the defibrillator, but the time needed to attach the defibrillator is not saved.

It should be further noted that the garment may have a special "emergency tearing" when there is a need for immediate defibrillation.

The invention being thus described in terms of embodiments and examples, it will be obvious that the same may be varied in many ways. Such variations are not to be regarded as a departure from the spirit and scope of the invention, and all such modifications as would be obvious to one skilled in the art are intended to be included within the scope of the following claims.

## WHAT IS CLAIMED IS:

1. An independent wearable health monitoring system, configured for use by a living being on a daily basis, including a healthy living being, the system comprising:
  - a) a knitted garment worn by the living being adjacently to preconfigured portions of the body of the living being;
  - b) a garment-processing device comprising:
    - i) a garment-processor; and
    - ii) a battery;
  - c) a multiplicity of sensors adapted to measure health parameters, wherein at least a portion of said sensors are integrally knitted with said knitted garment, and wherein said knitted textile sensors include electrodes or probe-devices adapted to provide ECG data; and
  - d) an interface adapted to operatively connect at least one external medical device to said garment-processing device,

wherein said garment-processing device is adapted to acquire said ECG data from said sensors and analyze said ECG data, and upon detecting at least one predefined abnormality in said ECG data, activating at least one pre-selected said external medical device configured to cope with said detected abnormality.

2. A health monitoring system as in claim 1 further comprising an alerting unit, wherein said garment-processing device, upon detecting at least one predefined abnormality in said ECG data, activates said alerting unit.
3. A health monitoring system as in claim 2, wherein said ECG data is a clinical level ECG data.
4. A health monitoring system as in claim 1, wherein said sensors include sensors for sensing blood pressure, oxygen saturation, breathing, temperature, dehydration, impedance, sweat analysis, lung fluids and heart rate.
5. A health monitoring system as in claim 1, wherein the health monitoring system is a seamless self-alert system.

6. A health monitoring system as in claim 1 further comprising at least one conductive knitted pad operatively disposed tightly adjacently to the skin of the monitored living being, wherein said at least one conductive knitted pad is adapted to facilitate placing of a respective defibrillator paddle thereon and applying defibrillator shocks.
7. A health monitoring system as in claim 6, wherein said garment-processing device is operatively connected to an apparatus controlling said at least one defibrillator paddle, and wherein said garment-processing device controls the activation and deactivation of said defibrillator shocks.
8. A health monitoring system as in claim 6, wherein said at least one defibrillator paddle is manually activated and deactivated.
9. A health monitoring system as in claim 6, wherein said knitted garment has a tubular form having variable elasticity, and wherein said at least one conductive knitted pad is operatively disposed tightly adjacently to the skin of the monitored living being.
10. A health monitoring system as in claim 6, wherein said garment-processing device further comprises protecting means to protect said garment-processing device from the current surge inflicted by the defibrillator onto said at least one conductive knitted pad.

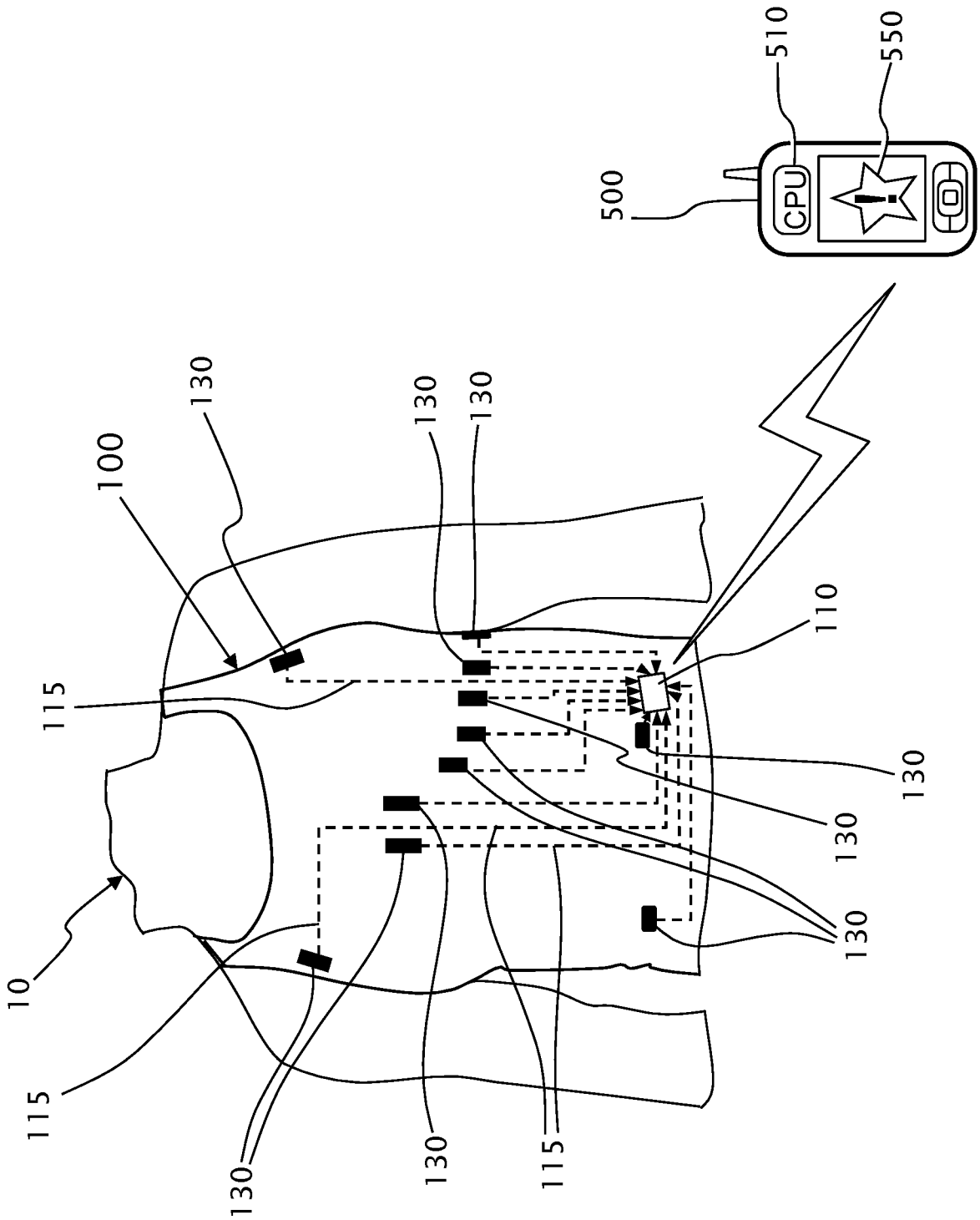

Fig. 1

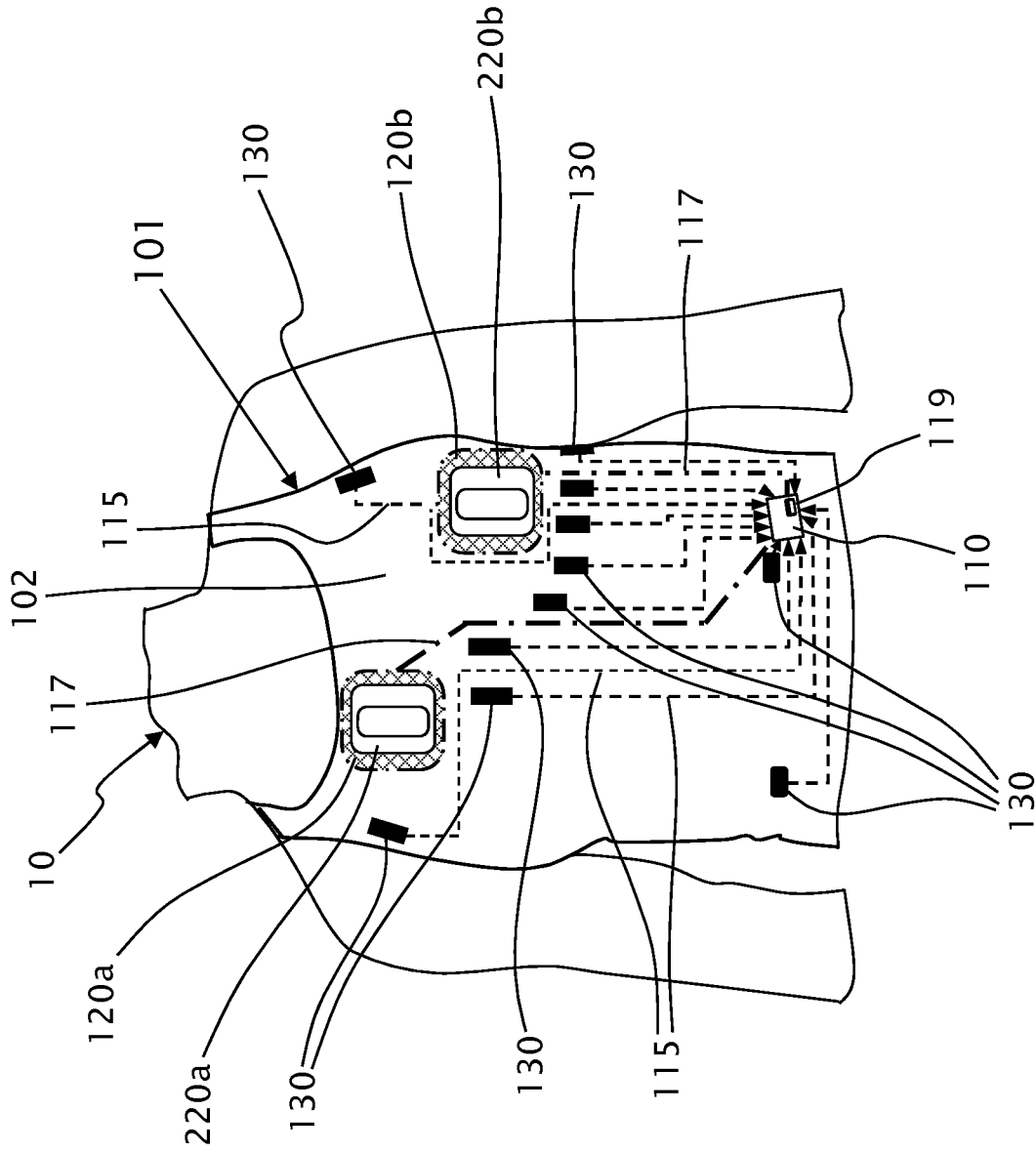

Fig. 2

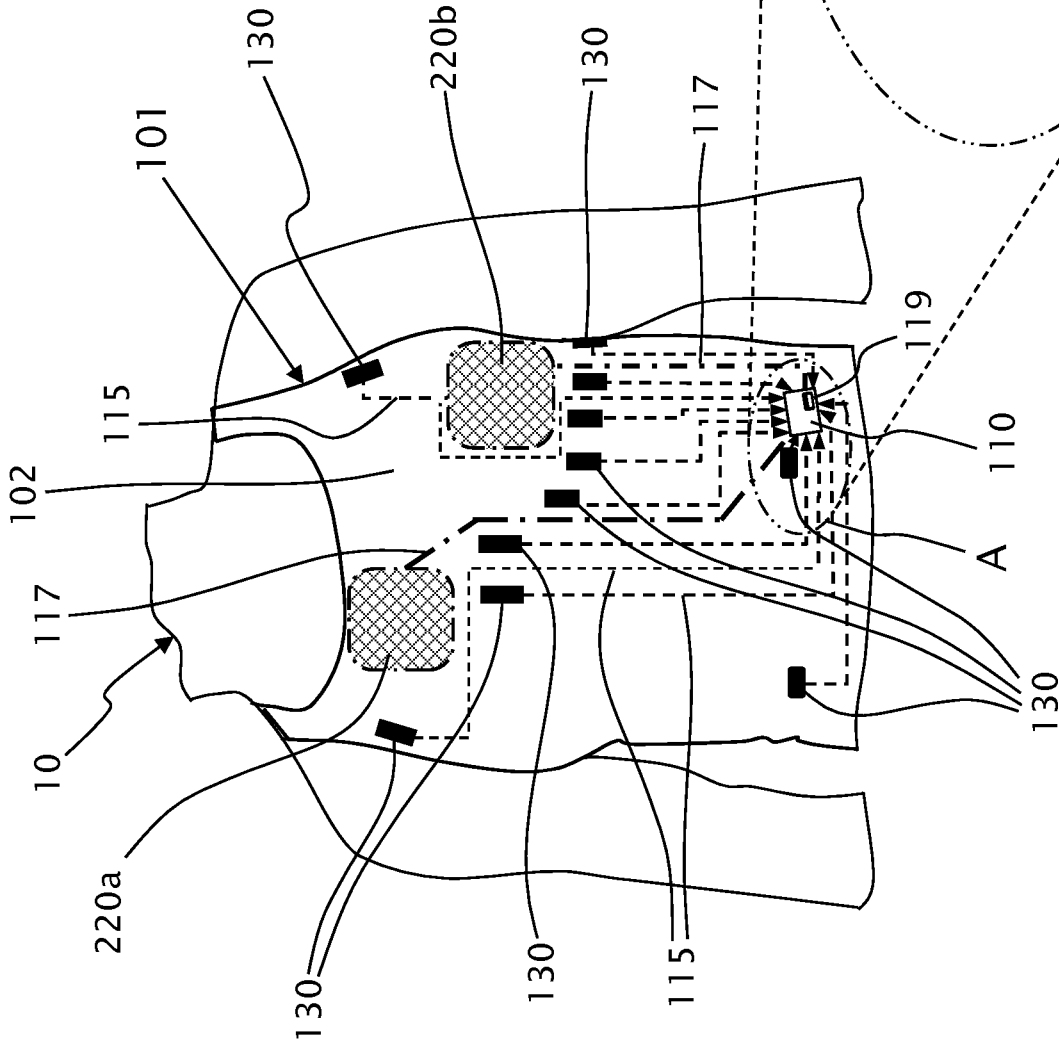

Fig. 3a

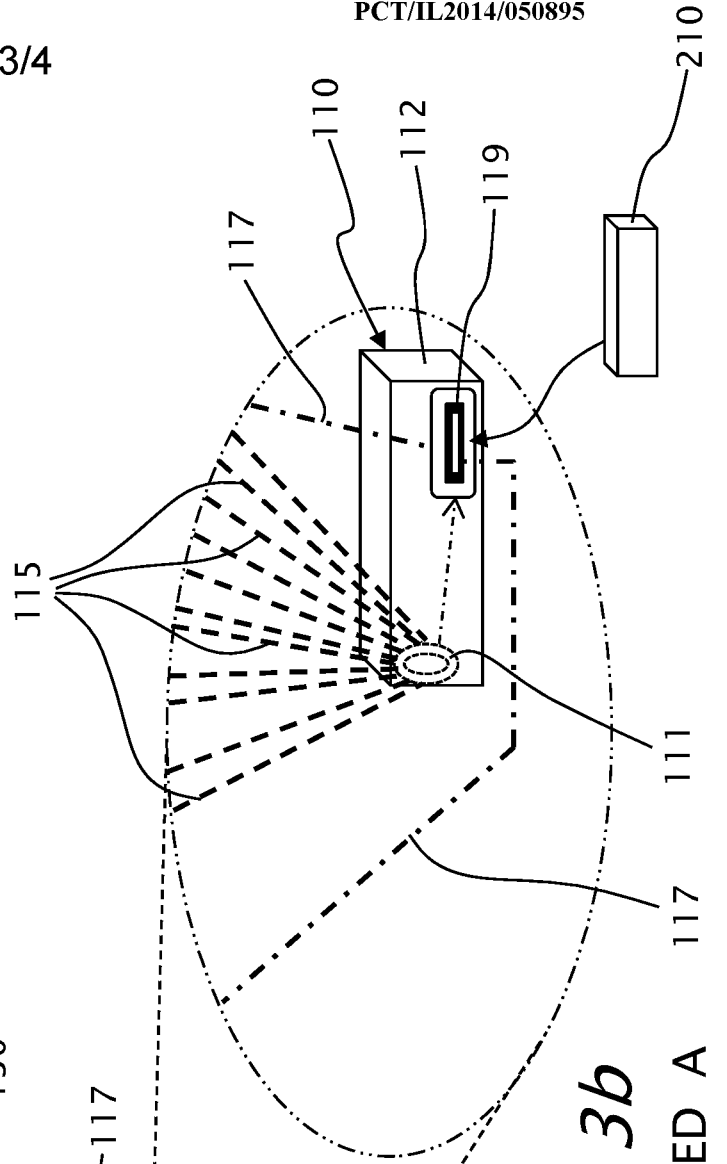

Fig. 3b

DETAILED A

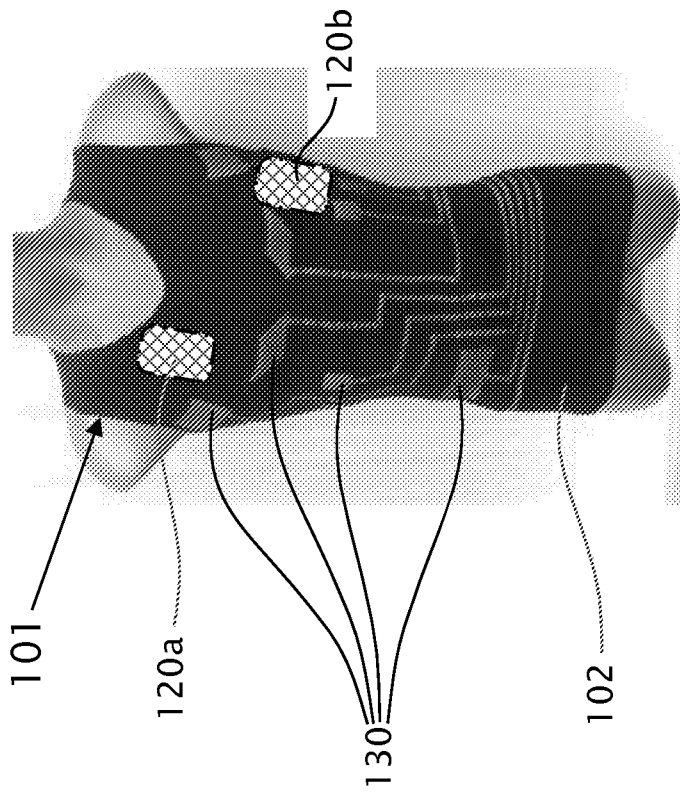

Fig. 4a

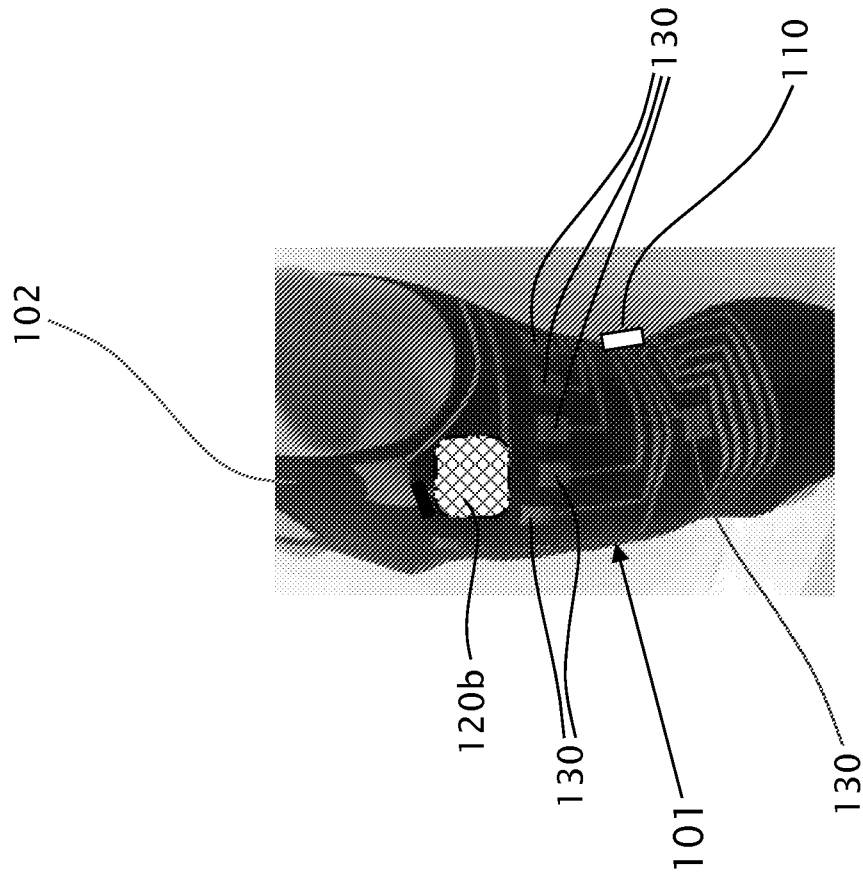

Fig. 4b

**INTERNATIONAL SEARCH REPORT**

International application No.

PCT/IL2014/050895

**A. CLASSIFICATION OF SUBJECT MATTER**

IPC (2015.01) A61B 5/00, A41D 1/00, A61N 1/39, H04W 4/22

According to International Patent Classification (IPC) or to both national classification and IPC

**B. FIELDS SEARCHED**

Minimum documentation searched (classification system followed by classification symbols)

IPC (2015.01) A61B 5/00, A61B, A41D 1/00, A61N 1/39, H04W 4/22

Documentation searched other than minimum documentation to the extent that such documents are included in the fields searched

Electronic data base consulted during the international search (name of data base and, where practicable, search terms used)

Databases consulted: PATENTSCOPE, THOMSON INNOVATION, Esp@cenet, Google Patents, PatBase

Search terms used: "medical device", garment\*, (sens\* or monitor), electrode\*, (paddle\* OR Defibr\*) connect\*

**C. DOCUMENTS CONSIDERED TO BE RELEVANT**

Category*	Citation of document, with indication, where appropriate, of the relevant passages	Relevant to claim No.
A	US 2011288604 A1 Kaib Thomas E et al 24 Nov 2011 (2011/11/24) Full document	1-10
A	US 2008306562 A1 Donnelly Edward J et al 11 Dec 2008 (2008/12/11) Full document	1-10
A	EP 1455640 B1 Philips Electronics N.V. 16 Jan 2008 (2008/01/16) Full document	1-10
A	US 2008306560 A1 Macho John D et al 11 Dec 2008 (2008/12/11) Full document	1-10
A	US 4928690 A Lifecor, Inc. 09 May 1990 (1990/05/09) Full document	1-10

Further documents are listed in the continuation of Box C.

See patent family annex.

\* Special categories of cited documents:

“A” document defining the general state of the art which is not considered to be of particular relevance

“E” earlier application or patent but published on or after the international filing date

“L” document which may throw doubts on priority claim(s) or which is cited to establish the publication date of another citation or other special reason (as specified)

“O” document referring to an oral disclosure, use, exhibition or other means

“P” document published prior to the international filing date but later than the priority date claimed

“T” later document published after the international filing date or priority date and not in conflict with the application but cited to understand the principle or theory underlying the invention

“X” document of particular relevance; the claimed invention cannot be considered novel or cannot be considered to involve an inventive step when the document is taken alone

“Y” document of particular relevance; the claimed invention cannot be considered to involve an inventive step when the document is combined with one or more other such documents, such combination being obvious to a person skilled in the art

“&” document member of the same patent family

Date of the actual completion of the international search

01 Feb 2015

Date of mailing of the international search report

10 Feb 2015

Name and mailing address of the ISA:

Israel Patent Office  
Technology Park, Bldg.5, Malcha, Jerusalem, 9695101, Israel  
Facsimile No. 972-2-5651616

Authorized officer

JOCHNOWITZ Gershon

Telephone No. 972-5651775

## INTERNATIONAL SEARCH REPORT

International application No.

PCT/IL2014/050895

C (Continuation). DOCUMENTS CONSIDERED TO BE RELEVANT		
Category*	Citation of document, with indication, where appropriate, of the relevant passages	Relevant to claim No.
A	US 5741306 A Lifecor, Inc. 21 Apr 1998 (1998/04/21) All document	1-10
A	US 6065154 A Lifecor, Inc. 23 May 2000 (2000/05/23) Full document	1-10
A	US 2009069857 A1 Heinz Bucher 12 Mar 2009 (2009/03/12) Full document	1-10
A	US 2008312709 A1 Volpe Shane S et al 18 Dec 2008 (2008/12/18) Full document	1-10
A	US 5348008 A Robert Bornn et al 20 Sep 1994 (1994/09/20) Full document	1-10
A	US 2012283794 A1 Kaib Thomas E et al 08 Nov 2012 (2012/11/08) Full document	1-10

**INTERNATIONAL SEARCH REPORT**  
Information on patent family members

International application No. PCT/IL2014/050895
--

Patent document cited search report	Publication date	Patent family member(s)	Publication Date
US 2011288604 A1	24 Nov 2011	US 2011288604 A1	24 Nov 2011
		CN 103025379 A	03 Apr 2013
		EP 2571572 A1	27 Mar 2013
		EP 2571572 A4	13 Nov 2013
		JP 2013526371 A	24 Jun 2013
		WO 2011146448 A1	24 Nov 2011
US 2008306562 A1	11 Dec 2008	US 2008306562 A1	11 Dec 2008
		US 8271082 B2	18 Sep 2012
		DE 102008025709 A1	14 May 2009
		FR 2916982 A1	12 Dec 2008
		FR 2916982 B1	11 Oct 2013
		JP 2008302228 A	18 Dec 2008
		JP 5492388 B2	14 May 2014
		JP 2014111162 A	19 Jun 2014
		US 2013013014 A1	10 Jan 2013
EP 1455640 B1	16 Jan 2008	EP 1455640 A2	15 Sep 2004
		EP 1455640 B1	16 Jan 2008
		AT 383812 T	15 Feb 2008
		AU 2002341332 A1	06 May 2003
		CN 1578639 A	09 Feb 2005
		CN 1297227 C	31 Jan 2007
		DE 60224717 D1	06 Mar 2008
		DE 60224717 T2	08 Jan 2009
		ES 2299606 T3	01 Jun 2008
		JP 2005506467 A	03 Mar 2005
		JP 4430934 B2	10 Mar 2010
		KR 20040048425 A	09 Jun 2004
		US 2003083593 A1	01 May 2003
		US 6755795 B2	29 Jun 2004

**INTERNATIONAL SEARCH REPORT**  
Information on patent family members

International application No.  
PCT/IL2014/050895

Patent document cited search report	Publication date	Patent family member(s)	Publication Date
		US 2004210165 A1	21 Oct 2004
		US 7211053 B2	01 May 2007
		WO 03034890 A2	01 May 2003
		WO 03034890 A3	17 Jun 2004
<hr/>			
US 2008306560 A1	11 Dec 2008	US 2008306560 A1	11 Dec 2008
		US 8369944 B2	05 Feb 2013
		DE 102008026871 A1	11 Dec 2008
		FR 2916981 A1	12 Dec 2008
		FR 2916981 B1	05 Jul 2013
		JP 2008302225 A	18 Dec 2008
		JP 5467733 B2	09 Apr 2014
		JP 2014111158 A	19 Jun 2014
		US 2013144355 A1	06 Jun 2013
		US 8774917 B2	08 Jul 2014
		US 2014324112 A1	30 Oct 2014
<hr/>			
US 4928690 A	09 May 1990	US 4928690 A	29 May 1990
		CA 1321814 C	31 Aug 1993
		CA 2043507 A1	30 Nov 1991
		CA 2043507 C	14 Apr 1998
		DE 68927898 D1	30 Apr 1997
		DE 68927898 T2	16 Oct 1997
		DE 69121470 D1	26 Sep 1996
		DE 69121470 T2	09 Jan 1997
		EP 0339471 A2	02 Nov 1989
		EP 0339471 A3	27 Nov 1991
		EP 0339471 B1	26 Mar 1997
		EP 0459239 A2	04 Dec 1991
		EP 0459239 A3	20 May 1992
		EP 0459239 B1	21 Aug 1996

**INTERNATIONAL SEARCH REPORT**  
Information on patent family members

International application No.  
PCT/IL2014/050895

Patent document cited search report	Publication date	Patent family member(s)	Publication Date
		JP H07541 A	06 Jan 1995
		JP 3001301 B2	24 Jan 2000
		JP H01320069 A	26 Dec 1989
		JP 2791095 B2	27 Aug 1998
		JP 2000051372 A	22 Feb 2000
		JP 3383611 B2	04 Mar 2003
		JP 2000051373 A	22 Feb 2000
		JP 3383612 B2	04 Mar 2003
		JP 2000051371 A	22 Feb 2000
		JP 3393092 B2	07 Apr 2003
		US 5078134 A	07 Jan 1992
<hr/>			
US 5741306 A	21 Apr 1998	US 5741306 A	21 Apr 1998
		CA 2205321 A1	23 Nov 1997
		CA 2205321 C	27 Mar 2001
		CA 2304348 A1	28 Dec 2000
		DE 69717192 D1	02 Jan 2003
		DE 69717192 T2	08 May 2003
		EP 0808639 A2	26 Nov 1997
		EP 0808639 A3	08 Dec 1999
		EP 0808639 B1	20 Nov 2002
		EP 1064963 A1	03 Jan 2001
		US 6097982 A	01 Aug 2000
		US 6280461 B1	28 Aug 2001
<hr/>			
US 6065154 A	23 May 2000	US 6065154 A	23 May 2000
		CA 2266784 A1	07 Oct 1999
		CA 2266784 C	31 Jul 2001
		EP 0948972 A2	13 Oct 1999
		EP 0948972 A3	13 Dec 2000
<hr/>			

**INTERNATIONAL SEARCH REPORT**  
Information on patent family members

International application No.  
PCT/IL2014/050895

Patent document cited search report	Publication date	Patent family member(s)	Publication Date
US 2009069857 A1	12 Mar 2009	US 2009069857 A1	12 Mar 2009
		US 8121683 B2	21 Feb 2012
		DE 102005054778 A1	24 May 2007
		DE 102005054778 B4	07 May 2009
		EP 1954350 A1	13 Aug 2008
		EP 1954350 B1	28 Sep 2011
		ES 2374604 T3	20 Feb 2012
		WO 2007057169 A1	24 May 2007
US 2008312709 A1	18 Dec 2008	US 2008312709 A1	18 Dec 2008
		US 7974689 B2	05 Jul 2011
		DE 102008020562 A1	02 Jan 2009
		EP 2590710 A1	15 May 2013
		FR 2917298 A1	19 Dec 2008
		FR 2917298 B1	20 Dec 2013
		JP 2008307382 A	25 Dec 2008
		JP 5478034 B2	23 Apr 2014
		JP 2013530776 A	01 Aug 2013
		JP 2014121629 A	03 Jul 2014
		US 2010298899 A1	25 Nov 2010
		US 8140154 B2	20 Mar 2012
		US 2012197353 A1	02 Aug 2012
		US 8649861 B2	11 Feb 2014
		US 2010312297 A1	09 Dec 2010
		US 8676313 B2	18 Mar 2014
		US 2014163334 A1	12 Jun 2014
		US 2014303680 A1	09 Oct 2014
WO 2012006524 A1	12 Jan 2012		
US 5348008 A	20 Sep 1994	US 5348008 A	20 Sep 1994
		AU 2908792 A	28 Jun 1993

**INTERNATIONAL SEARCH REPORT**  
Information on patent family members

International application No.  
PCT/IL2014/050895

Patent document cited search report	Publication date	Patent family member(s)	Publication Date
		EP 0615424 A1	21 Sep 1994
		EP 0615424 A4	25 Jan 1995
		US 5353793 A	11 Oct 1994
		US 5564429 A	15 Oct 1996
		WO 9310706 A1	10 Jun 1993
<hr/>			
US 2012283794 A1	08 Nov 2012	US 2012283794 A1	08 Nov 2012
		EP 2704625 A1	12 Mar 2014
		EP 2704625 A4	01 Oct 2014
		JP 2014516654 A	17 Jul 2014
		WO 2012151160 A1	08 Nov 2012
<hr/>			

专利名称(译)	独立的可穿戴健康监测系统，适用于与治疗设备的接口		
公开(公告)号	<a href="#">EP3057492A1</a>	公开(公告)日	2016-08-24
申请号	EP2014854403	申请日	2014-10-12
[标]申请(专利权)人(译)	株式会社自动网络技术研究所		
申请(专利权)人(译)	HEALTHWATCH LTD.		
当前申请(专利权)人(译)	HEALTHWATCH LTD.		
[标]发明人	ROMEM YORAM AMIR URI		
发明人	ROMEM, YORAM AMIR, URI		
IPC分类号	A61B5/00 A41D1/00 A61N1/39 H04W4/22 H04W4/90		
CPC分类号	A61B5/0006 A61B5/0024 A61B5/0205 A61B5/02055 A61B5/021 A61B5/02438 A61B5/04085 A61B5/0432 A61B5/053 A61B5/0816 A61B5/14542 A61B5/4836 A61B5/4875 A61B5/6804 A61B5/6805 A61N1/046 A61N1/0484 H04W4/80 H04W4/90 A61B5/04012 A61B5/0402 A61B5/746		
代理机构(译)	沃尔夫FELIX		
优先权	61/892475 2013-10-18 US		
其他公开文献	EP3057492A4		
外部链接	<a href="#">Espacenet</a>		

#### 摘要(译)

独立的可穿戴健康监测系统，配置为每天由生物使用。该系统包括由生活者穿着的与预先配置的身体位置相邻的针织服装，具有处理器的服装处理装置，以及适于测量健康参数的多个传感器，其中至少一些传感器与针织服装整体编织，并且其中编织纺织品传感器包括适于提供ECG数据的电极。该系统还包括适于将至少一个外部医疗设备可操作地连接到服装处理设备的接口。优选地，健康监测系统还包括两个导电的，整体编织的垫，其可操作地设置成与被监测的动物的皮肤紧密相邻，适于便于在其上放置相应的除颤器叶片并施加除颤器冲击。优选地，服装处理装置控制除颤器冲击的激活和停用。