

(19) World Intellectual Property
Organization
International Bureau



(43) International Publication Date
14 April 2005 (14.04.2005)

PCT

(10) International Publication Number
WO 2005/033701 A2

(51) International Patent Classification⁷: **G01N 33/50**

(21) International Application Number:
PCT/US2004/028505

(22) International Filing Date:
2 September 2004 (02.09.2004)

(25) Filing Language: English

(26) Publication Language: English

(30) Priority Data:
10/669,426 23 September 2003 (23.09.2003) US

(71) Applicant (for all designated States except US):
MEDTRONIC MINIMED, INC. [US/US]; 18000
Devonshire Street, Northridge, CA 91325 (US).

(72) Inventors; and

(75) Inventors/Applicants (for US only): **SHAH, Rajiv**
[US/US]; 28003 Lobrook, Rancho Palos Verdes, CA
90275 (US). **REGHABI, Bahar** [US/US]; 4652 Via Ma-
rina #209, Marina Del Rey, CA 90292 (US). **GOTTLIEB,**
Rebecca [US/US]; 3646 1/2 Schaefer Street, Culver City,
CA 90232 (US). **ENEGREN, Bradley, J.** [US/US]; 11253
Bentcreek Road, Moorpark, CA 93021 (US).

(74) Agent: **RITTMASER, Ted, R.**; Foley & Lardner, 35th
Floor, 2029 Century Park East, Los Angeles, CA 90067-
3021 (US).

(81) Designated States (unless otherwise indicated, for every
kind of national protection available): AE, AG, AL, AM,
AT, AU, AZ, BA, BB, BG, BR, BW, BY, BZ, CA, CH, CN,
CO, CR, CU, CZ, DE, DK, DM, DZ, EC, EE, EG, ES, FI,
GB, GD, GE, GH, GM, HR, HU, ID, IL, IN, IS, JP, KE,
KG, KP, KR, KZ, LC, LK, LR, LS, LT, LU, LV, MA, MD,
MG, MK, MN, MW, MX, MZ, NA, NI, NO, NZ, OM, PG,
PH, PL, PT, RO, RU, SC, SD, SE, SG, SK, SL, SY, TJ, TM,
TN, TR, TT, TZ, UA, UG, US, UZ, VC, VN, YU, ZA, ZM,
ZW.

(84) Designated States (unless otherwise indicated, for every
kind of regional protection available): ARIPO (BW, GH,
GM, KE, LS, MW, MZ, NA, SD, SL, SZ, TZ, UG, ZM,
ZW), Eurasian (AM, AZ, BY, KG, KZ, MD, RU, TJ, TM),
European (AT, BE, BG, CH, CY, CZ, DE, DK, EE, ES, FI,
FR, GB, GR, HU, IE, IT, LU, MC, NL, PL, PT, RO, SE, SI,
SK, TR), OAPI (BF, BJ, CF, CG, CI, CM, GA, GN, GQ,
GW, ML, MR, NE, SN, TD, TG).

Published:

— with declaration under Article 17(2)(a); without abstract;
title not checked by the International Searching Authority

For two-letter codes and other abbreviations, refer to the "Guid-
ance Notes on Codes and Abbreviations" appearing at the begin-
ning of each regular issue of the PCT Gazette.



WO 2005/033701 A2

(54) Title: IMPLANTABLE MULTI-PARAMETER SENSING SYSTEM AND METHOD

(57) Abstract:

PATENT APPLICATION IN THE U.S. PATENT AND TRADEMARK OFFICE

for

IMPLANTABLE MULTI-PARAMETER SENSING SYSTEM AND METHOD

by

Bahar Reghabi
Rebecca Gottlieb
Rajiv Shah
Bradley Enegren

BACKGROUND

1. Field of the Invention

[0001] Embodiments of the present invention relate to biomedical sensor technology and, in particular, to implantable, multi-parameter sensing systems and methods.

2. Description of Related Art

[0002] Continuous parameter measurement is important in the detection and monitoring of disease in patients. The ability to monitor biological or physiological parameters, analytes and other parameters in a patient in emergency rooms, intensive care units and other hospital settings is critical in stabilizing patients and reducing mortality rates. The monitoring of blood oxygen saturation, blood pressure, glucose, lactate, temperature, ion concentration, such as potassium, for example, and pH, for example, provides an indication of the state of tissue oxygen balance in the patient, knowledge of which is crucial in preventing a patient from progressing toward a serious, debilitating medical condition or even death.

[0003] Various situations require prompt monitoring and response to a change in body chemistry or other patient parameters. For example, sepsis, a toxic condition resulting from the spread of bacteria or their products from a focus of infection, can lead to global tissue hypoxia, multiple organ failures, cardiovascular collapse and eventual death. Increased blood lactate concentrations and decreased mixed venous oxygen saturation are classic indicators of the early phases of septic shock. By monitoring these

parameters, blood chemistry levels can be regulated and the incidence of sepsis decreased.

[0004] The prevention of sepsis is becoming increasingly important. Cases of sepsis occur more frequently in elderly persons than in younger populations. As the number of elderly persons nationwide and worldwide continues to increase, the number of cases of sepsis can be expected to increase as well.

[0005] Blood glucose is another parameter that requires monitoring in a medical setting in order to reduce injury and mortality rates. For example, for patients who are in an intensive care environment, especially those with diabetes, glucose monitoring is critical. If the amount of glucose in the diabetic patient's system is not maintained at proper levels, the patient may sustain serious or life-threatening injury. If too much glucose accumulates in the diabetic patient's system, the patient could become hyperglycemic, resulting in shortness of breath, nausea and vomiting at best or diabetic coma and death in the worst case. If there is too little glucose in the diabetic patient's system, the patient could become hypoglycemic, resulting in dizziness, sweating and headache at best and unconsciousness and death in the worst case.

[0006] Electrolyte and ion monitoring may have great potential for some electrolyte disorders. For example, low sodium or hyponatremia (an acute or chronic condition caused by kidney failure, pneumonia, meningitis, trauma, adrenal/pituitary gland insufficiency, congestive heart failure and cirrhosis) can cause water from the body fluids to move into the higher osmolarity tissue, causing the tissue to expand (edema). One clinical manifestation of this syndrome is increased brain pressure from cerebral edema. Potassium deficit (<3.5 mmol/L) has been linked with increased incidence of stroke in elderly individuals, especially those with arterial fibrillation. Additionally, serum potassium level has been a predictor of serious peri- and intra-operative arrhythmia, and postoperative arterial fibrillation.

[0007] Traditionally, the monitoring of patient parameters in a hospital or other medical setting has been accomplished by drawing a blood sample and sending the sample to a laboratory for analysis. This type of monitoring process, while well-established and providing accurate results, is time-consuming and, indeed, time-prohibitive in an emergency situation. By the time lab results return to an attending

physician, the patient may have already entered into a serious state or even may have already died.

[0008] Some industry attempts have been made to provide continuous, immediate monitoring of patient parameters. For example, Diametrics Medical, Inc., has developed several sensing systems for monitoring patient parameters, such as the NEUROTREND Sensor and the PARATREND7+ Sensors. The NEUROTREND Sensor is a disposable, single-use device for the continuous measurement of intra cranial pH, pCO₂, pO₂, and temperature that is used in conjunction with an appropriate intracranial access device. The device incorporates optical sensors and thermocouples for the measurement of pH, pCO₂, and pO₂, and a thermocouple for temperature measurement. The NEUROTREND sensor indicates the perfusion and metabolic acidosis /alkalosis status of cerebral tissue in the vicinity of the sensor. The PARATREND7+ Sensors are disposable, single-use fiber optic devices for continuous measurement of pH, pCO₂, pO₂ and temperature, providing real-time oxygenation, ventilation and metabolic information for critically ill patients.

[0009] However, the NEUROTREND Sensors and the PARATREND7+ Sensors have limited capabilities. Optical sensors lose effectiveness quickly when proteins deposit on their surface, which is inevitable in the body. The NEUROTREND Sensors and the PARATREND7+ Sensors, which are based on optical sensors, thus, tend to lose their effectiveness quickly. Accordingly, medical professionals must still use conventional techniques for obtaining reliable, quantifiable parameter values in addition to the values indicated by the NEUROTREND Sensors and the PARATREND7+ Sensors when administering to patients.

[0010] To date, there have been no implantable sensors providing continuous, quantifiable, simultaneous measurement values for patient parameters. In particular, there have been no implantable sensors providing continuous, quantifiable, simultaneous measurement values for lactate, glucose, pH, temperature, venous oxygen pressure, venous oxygen concentration and potassium. An implantable, multi-parameter sensor that monitors one or more of glucose, lactate, pH, temperature, venous oxygen pressure, venous oxygen concentration and blood potassium could be used advantageously in hospital or medical settings, in critical care, emergency care and intensive care situations, in triage, surgery and in field applications. For example, because a patient's blood

glucose concentration may increase during kidney dialysis, the monitoring of glucose, oxygen and temperature during dialysis may be helpful.

SUMMARY

[0011] It is therefore an object of embodiments of the present invention to provide a system and method for sensing and quantifying multiple parameters in a patient. It is a further object of embodiments of the present invention to provide a system and method for using an implantable, multi-parameter sensor that responds to a plurality of analytes simultaneously. It is yet a further object of embodiments of the present invention to provide a system and method for sensing multiple parameters that can be used in critical care, intensive care or emergency environments. It is yet a further object of embodiments of the present invention to provide a system and method for sensing multiple parameters that can provide continuous measurement of blood oxygen saturation, lactate, oxygen pressure, ion measurement, such as, potassium, hydrogen (pH) and sodium, for example, carbon dioxide, glucose and other ion concentrations.

[0012] A method of sensing multiple parameters may include implanting an implantable sensor at a single site in a patient, the implantable sensor having a housing within which are disposed a plurality of implantable sensing elements; and reading an output from at least one of the implantable sensing elements. A plurality of parameters may be read from the implantable sensor at the single site. The output read from at least one of the implantable sensing elements may be a quantifiable value. Also, at least one of the implantable sensing elements may be a biological parameter sensor, a physiological parameter sensor or an analyte sensor. Reading an output from at least one of the implantable sensing elements may include reading an output from the at least one implantable sensing element that responds to lactate, blood oxygen saturation, blood pressure, glucose, blood temperature, potassium or pH.

[0013] The method may also include administering therapy to the patient based on the output read from the at least one implantable sensing element. Administering therapy may include administering therapy for myocardial ischemia, myocardial infarction, sepsis, septic shock or angina. Administering therapy may also include adjusting a function or a placement of an implantable cardiovascular defibrillator

disposed within the patient or administering therapy for a patient receiving extracorporeal membrane oxygenation. The method may also include classifying a severity of a condition of the patient or classifying a worsening condition of the patient. The method may be used in a surgical environment in an intensive care environment.

[0014] A method of evaluating a patient may include implanting an implantable sensor at a single site in a patient, the implantable sensor having a housing within which are disposed a plurality of implantable sensing elements; reading an output from at least one of the implantable sensing elements; and evaluating the patient based on the output read from the at least one implantable sensing element. A plurality of parameters may be read from the implantable sensor at the single site. The output read from at least one of the implantable sensing elements may be a quantifiable value. Evaluating the patient may include evaluating the patient based on an output from the at least one implantable sensing element that responds to lactate or from at least one implantable sensing element that responds to blood oxygen saturation, blood pressure, glucose, blood temperature, potassium or pH.

[0015] Evaluating the patient may also include evaluating the patient for myocardial ischemia, myocardial infarction, angina, sepsis or septic shock or any other condition or situation. Evaluating the patient may also include evaluating the patient having an implantable cardiovascular defibrillator or evaluating the patient receiving extracorporeal membrane oxygenation.

BRIEF DESCRIPTION OF THE DRAWINGS

[0016] Figure 1 shows a perspective view of an apparatus for sensing multiple parameters according to an embodiment of the present invention.

[0017] Figure 2 shows a perspective view of another apparatus for sensing multiple parameters according to an embodiment of the present invention.

[0018] Figure 3 shows a generalized method for using an implantable, multi-parameter sensor according to an embodiment of the present invention.

[0019] Figure 4 shows a method for using an implantable, multi-parameter sensor according to an embodiment of the present invention.

[0020] Figure 5 shows another method for using an implantable, multi-parameter sensor according to an embodiment of the present invention.

[0021] Figure 6 shows another method for using an implantable, multi-parameter sensor according to an embodiment of the present invention.

[0022] Figure 7 shows another method for using an implantable, multi-parameter sensor according to an embodiment of the present invention.

[0023] Figure 8 shows another method for using an implantable, multi-parameter sensor according to an embodiment of the present invention.

[0024] Figure 9 shows a block diagram of an apparatus for sensing multiple parameters implanted in a patient according to an embodiment of the present invention.

[0025] Figure 10 shows a block diagram of another apparatus for sensing multiple parameters implanted in a patient according to an embodiment of the present invention.

[0026] Figure 11 shows a block diagram of another apparatus for sensing multiple parameters implanted in a patient according to an embodiment of the present invention.

DETAILED DESCRIPTION

[0027] In the following description of preferred embodiments, reference is made to the accompanying drawings which form a part hereof, and in which are shown by way of illustration specific embodiments in which the invention may be practiced. It is to be understood that other embodiments may be utilized and structural changes may be made without departing from the scope of the preferred embodiments of the present invention.

[0028] Although the following description is directed primarily toward systems and methods for sensing multiple parameters in a patient, embodiments of the present invention may be used in a variety of capacities and applications. For example, embodiments of the present invention may be used for critical care, intensive care or emergency environments or in triage, surgery and in field applications or, for example, in particular medical or surgical procedures, such as dialysis or cardiac bypass, for example. Also, embodiments of the present invention may be used in hospitals to simultaneously measure multiple analytes. Generally, embodiments of the present invention may be adapted for use in any type of medical or hospital situation where simultaneous measurement of biological or physiological parameters or analytes is desired.

[0029] An apparatus for sensing multiple parameters 10 according to an embodiment of the present invention may be seen in Fig. 1. The apparatus for sensing multiple parameters 10 shown in Fig. 1 includes, but is not limited to, a housing 14, a plurality of sensors 12a-12e, a tip 16 and an interconnect 18. The housing 14 may also include one or more apertures 20 for permitting physical or other contact between fluids in the body and sensing elements located on each of the plurality of sensors 12a-12e.

[0030] Each of the plurality of sensors 12a-12e may be designed to sense one or more parameters. For example, each of the plurality of sensors 12a-12e may be designed to sense a biological or physiological parameter in a patient, such as, for example, blood oxygen saturation, blood pressure, blood temperature, or blood pH. Also, each of the plurality of sensors 12a-12e may be designed to sense a parameter such as an analyte in a patient, such as, for example, glucose, lactate, potassium, pH, sodium, pCO_2 , pO_2 , SvO_2 , pvO_2 , temperature and urea. Accordingly, given the various mechanisms required to sense various parameters, each of the plurality of sensors 12a-12e may be designed as an electrochemical sensor, a potentiometric sensor, a current sensor, a physical quantity sensor, an optical sensor or other type of sensor, dictated by the parameter being measured. In addition, the output of one or more of the plurality of sensors 12a-12e may be a quantifiable value. In other words, a measurement may be made by one or more of the plurality of sensors 12a-12e such that a quantifiable or absolute value is returned by the sensor.

[0031] Although the embodiment of the present invention shown in Fig. 1 includes five sensors, embodiments of the present invention may be designed with any number of sensors desired or necessary for a particular application. For example, an embodiment of the present invention shown in Fig. 5 includes, without limitation, three sensors.

[0032] The plurality of sensors 12a-12e shown in Fig. 1 are "daisy-chained" together via the interconnect 18. Because "daisy-chaining" modules is facilitated by digital addressing, each of the plurality of sensors 12a-12e shown in the embodiment of Fig. 1 includes an analog-to-digital (A/D) converter integrated circuit as well as a power supply for powering the integrated circuit, such as, for example, a capacitor. Thus,

because each of the plurality of sensors 12a-12e includes an onboard A/D, the information leaving the housing 14 on the interconnect 18 is in digital form.

[0033] Also, each of the plurality of sensors 12a-12e may be individually addressed by a remote device, such as, for example, a computer or other controller. The addressing schemes may be any scheme common in the industry and may include, without limitation, frequency modulation or time modulation schemes.

[0034] The housing 14 may be fabricated in a variety of ways. For example, the housing 14 may be a single, standard catheter that is flexible for vascular placement. If the housing 14 is a flexible catheter, the apparatus for sensing multiple parameters 10 may be placed independently in the body. In addition, the housing 14 may be one lumen of a multi-lumen catheter or may be part of a central venous line or sheath. According to an embodiment of the present invention, the housing 14 may be made of silicone or a polyethylene, for example.

[0035] According to an embodiment of the present invention, the tip 16 may be an ogive shape, i.e., a "bullet nose." An ogive-shaped tip 16 may optimize a flow field around the apparatus for sensing multiple parameters 10 and, being curved, may be less likely to gouge the patient during insertion. According to another embodiment of the present invention, the tip 16 may have some sort of structure, such as, for example, a screw anchor or other structure, allowing it to be fixed into tissue.

[0036] Fig. 2 shows an apparatus for sensing multiple parameters 30 according to another embodiment of the present invention. The apparatus for sensing multiple parameters 30 includes, but is not limited to, a plurality of sensors 32a-32e, a housing 34, a tip 36 and an interconnect 38. The housing 34 may also include one or more apertures 40 allowing fluids in the body to come into physical contact with the sensors 32a-32e.

[0037] Whereas each of the plurality of sensors 12a-12e of Fig. 1 were daisy-chained together, the plurality of sensors 32a-32e in Fig. 2 operate independently of one another and are individually wired. In other words, according to the embodiment of the present invention shown in Fig. 2, each of the plurality of sensors 32a-32e has a wire connected to it that is routed out of the housing 34 such that the interconnect 38 is actually a plurality of interconnects. Because there is no daisy-chain configuration in the embodiment of the invention shown in Fig. 2, there is no need for each of the plurality of

sensors 32a-32e to be digitally addressable. Each of the plurality of sensors 32a-32e may transmit or receive an analog signal; there is no requirement to include an onboard A/D integrated circuit and associated power supply. Without the A/D integrated circuit and associated power supply, the “wired” sensing apparatus 30 according to the embodiment of the present invention shown in Fig. 2 may have a reduced size, making it flexible and desirable for medical and/or surgical use.

[0038] Embodiments of the present invention need not be limited to a “daisy-chained” sensing apparatus as shown in Fig. 1 or a “wired” sensing apparatus as shown in Fig. 2. Embodiments of the present invention may also include, without limitation, a combination of daisy-chained and wired configurations.

[0039] The sensors 12a-12e and 32a-32e shown in the embodiments of the invention of Fig. 1 and Fig. 2 may be physically disposed in a variety of ways. For example, the plurality of sensors 12a-12e shown in Fig. 1 and the plurality of sensors 32a-32e shown in Fig. 2 are arranged in a “perpendicular” fashion. In other words, in the embodiments of the invention shown in Figs. 1 and 2, each sensor is aligned perpendicularly or is “on its side” relative to the sensor adjacent to it. Thus, according to embodiments of the present invention, flexibility in position and/or orientation may be achieved. For example, according to embodiments of the present invention, a drug may be dosed in a perpendicular fashion on one half of the catheter while a parameter may be measured on another half of the catheter. Also, in embodiments of the invention in which all sensing elements are disposed on one side of the catheter, for example, the catheter may be rotated or positioned in multiple orientations to determine a variance in readings for a particular environment, thus indicating whether an environment is “well-mixed.”

[0040] A generalized method for using an implantable, multi-parameter sensor according to an embodiment of the present invention is shown in Fig. 3. According to the embodiment of the invention shown in Fig. 3, an implantable, multi-parameter sensor is positioned in a patient at step 40. The implantable, multi-parameter sensor may be inserted into the vasculature. According to other embodiments of the present invention, the implantable, multi-parameter sensor may be positioned in the peritoneal or may be positioned subcutaneously, or, for example, may be positioned in ventricular spaces, neurological spaces, such as the spine or brain, for example, intramuscular, myocardial,

or pericardial spaces, and all vascular (venous and arterial) spaces. According to embodiments of the present invention, the implantable, multi-parameter sensor may also be positioned outside the body, for example, in an extracorporeal membrane oxygenation (ECMO) system.

[0041] At step 42, parameters are monitored using the implantable, multi-parameter sensor. According to embodiments of the present invention, a variety of parameters may be monitored. For example, lactate, blood oxygen saturation, potassium pH, blood pressure, glucose and blood temperature may be monitored. In addition, the parameters monitored may be monitored continuously or may be used to trigger alarms. According to other embodiments of the present invention, the parameters monitored may be used to suggest treatment for a patient based on measured values. Also, embodiments of the invention may be used in a variety of applications. For example, because a patient's blood glucose concentration may increase during kidney dialysis, embodiments of the invention may be used to monitor glucose, oxygen and temperature during dialysis. Also, for example, embodiments of the invention may be used to monitor parameters during surgical procedures, such as cardiac bypass, for example, or during triage.

[0042] At step 44, a risk level may be assessed or a therapy may be administered in response to the parameter levels sensed using the implantable, multi-parameter sensor. For example, based on the sensed level of a particular parameter, a medical professional may determine that the patient is at high-risk for a debilitating medical condition and an appropriate course of action may be commenced. According to another embodiment of the present invention, based on the sensed level of a particular parameter, a particular type of therapy may be administered, such as, for example, delivery to the patient of a particular drug.

[0043] A method for using an implantable, multi-parameter sensor in connection with myocardial ischemia according to an embodiment of the present invention is shown in Fig. 4. Myocardial ischemia, a condition in which oxygen deprivation to the heart muscle is accompanied by inadequate removal of metabolites because of reduced blood flow or perfusion, occurs due to an imbalance between myocardial oxygen supply and demand. According to embodiments of the present invention, myocardial ischemia may be monitored using an implantable, multi-parameter sensor.

[0044] According to an embodiment of the present invention shown in Fig. 4, an implantable, multi-parameter sensor is positioned in a patient at step 50. The implantable, multi-parameter sensor may be inserted into the vasculature. According to other embodiments of the present invention, the implantable, multi-parameter sensor may be positioned in the peritoneal or may be positioned subcutaneously or, for example, may be positioned in ventricular spaces, neurological spaces, such as the spine or brain, for example, intramuscular, myocardial, or pericardial spaces, and all vascular (venous and arterial) spaces. According to embodiments of the present invention, the implantable, multi-parameter sensor may also be positioned outside the body, for example, in an ECMO system.

[0045] At step 52, a variety of parameters may be monitored in connection with myocardial ischemia using the implantable, multi-parameter sensor. According to embodiments of the present invention, lactate levels, blood oxygen saturation, base deficit and pH, for example, may be monitored in connection with myocardial ischemia. Also, these and other parameters may be continuously monitored. Insufficient myocardial ischemia (or perfusion) may lead to irreversible cell damage and/or myocardial infarction. Also, the transition from myocardial ischemia to myocardial infarction happens over the course of several hours and, during this period, blood lactate concentrations elevate and remain elevated until tissue reperfusion.

[0046] At step 54, a risk may be assessed or a therapy administered for myocardial ischemia. Because blood lactate concentrations elevate and remain elevated during the transition from myocardial ischemia to myocardial infarction, the monitoring of lactate concentrations may be a predictor of heart attacks. Thus, if high levels of lactate are monitored using the implantable, multi-parameter sensor, the risk of heart attack may be assessed and appropriate medication administered. Also, in the case of a myocardial infarction, "clot-busting" drugs need to be administered within the first few hours of the event.

[0047] A method for using an implantable, multi-parameter sensor in connection with myocardial infarction or angina according to an embodiment of the present invention is shown in Fig. 5. Myocardial infarction implies a death of heart muscle cells resulting from lack of oxygen supply and supply of other nutrients due to closure of the

coronary artery. Lack of oxygen, otherwise known as tissue hypoxia, or oxygen imbalance, causes tissue metabolism to shift from aerobic to anaerobic. This shift results in increased tissue and blood lactate concentrations. Global tissue hypoxia may indicate serious illness and may precede multiple organ failure and death.

[0048] Angina is a discomfort experienced in the chest, arms neck or back by patients with coronary artery disease and indicates that the heart muscle is not getting enough blood. According to embodiments of the present invention, myocardial infarction and angina may be monitored using an implantable, multi-parameter sensor.

[0049] According to an embodiment of the present invention shown in Fig. 5, an implantable, multi-parameter sensor is positioned in a patient at step 60. The implantable, multi-parameter sensor may be inserted into the vasculature. According to other embodiments of the present invention, the implantable, multi-parameter sensor may be positioned in the peritoneal or may be positioned subcutaneously.

[0050] At step 62, a variety of parameters may be monitored in connection with myocardial infarction and angina using the implantable, multi-parameter sensor. According to embodiments of the present invention, lactate levels, blood oxygen saturation, base deficit and pH, for example, may be monitored in connection with myocardial infarction and angina. Also, these parameters may be continuously monitored. For example, potassium deficit has been linked with increased incidence of stroke in elderly individuals and an increase in atrial fibrillation after cardiac surgery.

[0051] At step 64, a risk may be assessed or a therapy administered for myocardial ischemia. Ischemic myocardium releases lactate in a quantitative relation to the extent of ischemia. At least one animal study has shown that 5-, 15- and 45 minute ischemic events result in 2.80, 9.27 and 6.11 mM blood lactate concentrations, respectively. Thus, the transition from myocardial ischemia to myocardial infarction and angina may be inferred from the shape of a blood lactate concentration curve with respect to time. Then, a state of myocardial infarction may be assessed and appropriate medication administered.

[0052] A method for using an implantable, multi-parameter sensor in connection with the function and placement of an implantable cardiovascular defibrillator (ICD) according to an embodiment of the present invention is shown in Fig. 6. According to an

embodiment of the present invention shown in Fig. 6, an implantable, multi-parameter sensor is positioned in a patient at step 70. The implantable, multi-parameter sensor may be inserted into the vasculature. According to other embodiments of the present invention, the implantable, multi-parameter sensor may be positioned in the peritoneal or may be positioned subcutaneously.

[0053] At step 72, a variety of parameters may be monitored in connection with the ICD using the implantable, multi-parameter sensor. According to embodiments of the present invention, lactate levels, blood oxygen saturation, base deficit and pH, for example, may be monitored in connection with the ICD in a patient. Also, these parameters may be continuously monitored.

[0054] At step 74, the function and placement of the ICD may be evaluated. For example, the trends in level and frequency of electrical shocks or pulses generated by the ICD relative to lactate levels, blood oxygen saturation, base deficit, blood pH or other parameters may be tracked and monitored. Depending on the efficacy of the ICD in connection with the levels of the monitored parameters, the functioning of the ICD may be adjusted to improve its effects. In addition, the appropriateness of the placement or positioning of the ICD may be evaluated. For example, the placement of the ICD may be adjusted if a medical professional determines that, given the frequency and levels of electrical shocks or pulses generated by the ICD relative to lactate levels, blood oxygen saturation, base deficit, blood pH or other parameters, a more advantageous position within the patient is desirable.

[0055] A method for using an implantable, multi-parameter sensor in connection with sepsis or septic shock according to an embodiment of the present invention is shown in Fig. 7. Sepsis, defined by the presence of toxins from pathogenic organisms in the blood or tissue, often leads to global tissue hypoxia, multiple organ failure, such as sudden cardiovascular collapse, for example, and eventual death. Increased lactate concentrations and decreased mixed venous oxygen saturation are typical signs of early phases of septic shock. Lactate concentrations remain elevated throughout sepsis.

[0056] Sepsis is responsible for as many deaths as myocardial infarction. Severe sepsis and septic shock may be mitigated by using embodiments of the present invention. Severe sepsis and septic shock may be mitigated by continuously monitoring lactate

levels in a patient. The concentration of lactate in the blood increases as a patient enters a septic phase. In addition, the concentration of blood potassium typically lowers as a patient enters a septic phase while central venous pressure drops. Also, according to some schools of thought, venous O₂ can rise as a patient becomes septic or is going through sepsis. Thus, embodiments of the present invention may be used to continuously monitor blood lactate, venous O₂, potassium and central venous pressure. According to embodiments of the present invention, sepsis and septic shock may be monitored using an implantable, multi-parameter sensor.

[0057] According to an embodiment of the present invention shown in Fig. 7, an implantable, multi-parameter sensor is positioned in a patient at step 80. The implantable, multi-parameter sensor may be inserted into the vasculature. According to other embodiments of the present invention, the implantable, multi-parameter sensor may be positioned in the peritoneal or may be positioned subcutaneously.

[0058] At step 82, a variety of parameters may be monitored in connection with sepsis or septic shock using the implantable, multi-parameter sensor. According to embodiments of the present invention, lactate levels, blood oxygen saturation, base deficit and pH, for example, may be monitored in connection with sepsis or septic shock in a patient. Also, these parameters may be continuously monitored.

[0059] At step 84, a risk may be assessed or a therapy administered for sepsis or septic shock. By continuously monitoring blood lactate, venous O₂, potassium and central venous pressure, a physician or other medical attendant may administer to the patient responsive treatment based on the monitored parameters and prevent the patient from becoming septic.

[0060] A method for using an implantable, multi-parameter sensor in connection with ECMO according to an embodiment of the present invention is shown in Fig. 8. ECMO, a form of therapy supporting heart and lung functions in a patient when the patient's own heart and lung functions are inadequate, is typically administered from three to twenty-one days depending on the severity of the condition. Children typically require ECMO support from five to seven days. ECMO is typically performed on neonates but is also performed on adults. In ECMO, blood is drained from a patient through a catheter and is pumped through a membrane oxygenator serving as an artificial

lung, adding oxygen into the blood and removing carbon dioxide from the blood. The blood then reenters the patient through a catheter placed in an artery. According to embodiments of the present invention, patient condition during ECMO therapy may be monitored using an implantable, multi-parameter sensor.

[0061] Also, hypoxia and hypertension are common not only in critically ill adults but also in sick neonates, particularly pre-term infants receiving intensive care. Hyperlactataemia is associated with increased mortality in premature infants with respiratory distress syndrome (RDS) and respiratory failure patients receiving ECMO. Hyperlactataemia in neonates is defined as an arterial blood lactate concentration above 2.5 mM.

[0062] According to an embodiment of the present invention shown in Fig. 8, an implantable, multi-parameter sensor is positioned in a patient at step 90. The implantable, multi-parameter sensor may be inserted into the vasculature. According to other embodiments of the present invention, the implantable, multi-parameter sensor may be positioned in the peritoneal or may be positioned subcutaneously, or, for example, may be positioned in ventricular spaces, neurological spaces, such as the spine or brain, for example, intramuscular, myocardial, or pericardial spaces, and all vascular (venous and arterial) spaces. According to embodiments of the present invention, the implantable, multi-parameter sensor may also be positioned outside the body, for example, in an ECMO system.

[0063] At step 92, a variety of parameters may be monitored in connection with ECMO using the implantable, multi-parameter sensor. According to embodiments of the present invention, lactate levels, blood oxygen saturation, base deficit and pH, for example, may be monitored in connection with the administration of ECMO. Also, these parameters may be continuously monitored.

[0064] At step 94, a risk may be assessed or a therapy administered in connection with the administration of ECMO. By continuously monitoring blood lactate, blood oxygen saturation, base deficit, pH and other parameters, a physician or other medical attendant may administer to the patient responsive treatment based on the monitored parameters and the effects of the ECMO.

[0065] A block diagram of a multi-parameter sensing system 100 with a multi-parameter sensor implanted in a patient may be seen in Fig. 9. In Fig. 9, an apparatus for sensing multiple parameters 102 is inserted into a patient 101. A catheter portion 104 of the apparatus for sensing multiple parameters 102 exits the patient 101 at an incision 106 and extends out of the patient 101. If the apparatus for sensing multiple parameters 102 shown in Fig. 9 is a daisy-chained apparatus, the information present on the interconnect 108 may be in digital form and may be connected directly to a computer 112 or other analytical device. The apparatus for sensing multiple parameters 102 in Fig. 9 may also include an infusion line 110 which may be connected to an infusant delivery system 114 or other delivery system.

[0066] A block diagram of a multi-parameter sensing system 120 according to another embodiment of present the present invention may be seen in Fig. 10. In Fig. 10, an apparatus for sensing multiple parameters 122 is implanted in a patient 121. A catheter portion 124 of the apparatus for sensing multiple parameters 122 exits the patient 121 at an incision 126 and extends out of the patient 121. In the embodiment of the invention shown in Fig. 10, if the apparatus for sensing multiple parameters 122 is a "wired" sensing apparatus, the information contained on the interconnect 128 may be in analog form. The interconnect 128, which may be a plurality of interconnects, may be connected to an analog-to-digital converter (A/D) 136. The information coming out of the A/D 136 is in digital form and may be connected to a computer 132 or other analytical device. According to another embodiment of the present invention, the information contained on the interconnect 128, being in analog form, may also be connected directly to an oscilloscope or other analytical device. The multi-parameter sensing system 120 may also include an infusion line 130 which may be connected to an infusant delivery system 134.

[0067] A block diagram of a multi-parameter sensing system 140 according to another embodiment of present the present invention may be seen in Fig. 11. In Fig. 11, an apparatus for sensing multiple parameters 142 is implanted in a patient 156. A catheter portion 144 of the apparatus for sensing multiple parameters 142 exits the patient 156 at an incision 146 and extends out of the patient 156. In the embodiment of the invention shown in Fig. 11, one of the sensors in the apparatus for sensing multiple

parameters 142 includes an internal electrode which cooperates with an external electrode 154. An first interconnect 148, which includes a signal from the internal electrode on one of the sensors in the apparatus for sensing multiple parameters 142, and a second interconnect 150 are connected to a computer or other controller/analyzer 152. The computer or other controller/analyzer 152 is able to sense a change of impedance between the internal electrode on one of the sensors in the apparatus for sensing multiple parameters 142 and the external electrode 154, corresponding to a change in the chemical, biological or physiological make-up of the area between the two electrodes, i.e., the patient.

[0068] For example, if a patient enters a state of edema, an increase in fluid in body tissue, the embodiment of the present invention shown in Fig. 11 could be used to detect the edema. An increase in fluid in body tissue may correspond to a change in the impedance of the body tissue, which would be sensed by the internal electrode and the external electrode 154. Edema is also associated with low sodium concentration or hyponatremia. Low sodium levels may cause body fluids to move into the higher osmolarity tissue, causing tissue to expand (edema). One clinical manifestation of this syndrome is increased brain pressure from cerebral edema.

[0069] Embodiments of the present invention may also be used to maintain proper insulin levels, especially in diabetics. For example, according to an embodiment of the present invention, blood glucose may be monitored and insulin levels adjusted accordingly to prevent a patient from becoming hypoglycemic or hyperinsulinemic. Along with glucose, O₂ and temperature measurements may be made to assist the medical professional in determining the most advantageous time and manner to adjust the patient's insulin to the proper levels.

[0070] Embodiments of the present invention allow medical professionals to use one sensing apparatus to measure multiple parameters. Thus, the medical and surgical risks involved by placing multiple devices or sensors on a patient to measure desired parameters are reduced.

[0071] Embodiments of the present invention may be used in vascular or non-vascular applications. For example, sensors according to embodiments of the present invention be inserted into the vasculature. According to other embodiments of the

present invention, sensors may be positioned in the peritoneal or may be positioned subcutaneously or, for example, may be positioned in ventricular spaces, neurological spaces, such as the spine or brain, for example, intramuscular, myocardial, or pericardial spaces, and all vascular (venous and arterial) spaces. According to embodiments of the present invention, the implantable, multi-parameter sensor may also be position outside the body, for example, in an ECMO system. Embodiments of the present invention may also be used for intracranial or defibrillation applications.

[0072] Embodiments of the present invention may also be used to classify the severity of a disease of a patient. For example, embodiments of the present invention may be useful in assisting physicians or other medical professionals in determining a patient's Simplified Acute Physiology Score (SAPS), Multiple Organ Dysfunction Score (MODS) or other scoring index. In addition, embodiments of the present invention may be used in connection with grading systems such as the Acute Physiology and Chronic Health Evaluator (APACHE), for example.

[0073] Embodiments of the present invention may be used in a variety of environments. For example, embodiments of the present invention may be used in point-of-care testing or in a surgical, emergency, critical care or intensive care environment.

[0074] Embodiments of the present invention may also be used with other devices. For example, embodiments of the present invention may be used with heart pacemakers and defibrillators. In addition, embodiments of the present invention may be used in connection with internal or external pumps. For example, embodiments of the present invention may be used along with an implantable insulin pump.

[0075] While particular embodiments of the present invention have been shown and described, it will be obvious to those skilled in the art that the invention is not limited to the particular embodiments shown and described and that changes and modifications may be made without departing from the spirit and scope of the appended claims.

CLAIMS

What is claimed is:

1. A method of sensing multiple parameters comprising:
implanting an implantable sensor at a single site in a patient, the implantable sensor having a housing within which are disposed a plurality of implantable sensing elements; and
reading an output from at least one of the implantable sensing elements,
wherein a plurality of parameters are read from the implantable sensor at the single site, and
wherein the output read from at least one of the implantable sensing elements is a quantifiable value.
2. The method of Claim 1, wherein at least one of the implantable sensing elements is a biological parameter sensor.
3. The method of Claim 1, wherein at least one of the implantable sensing elements is a physiological parameter sensor.
4. The method of Claim 1, wherein at least one of the implantable sensing elements is an analyte sensor.
5. The method of Claim 1, wherein reading an output from at least one of the implantable sensing elements comprises reading an output from an implantable sensing element that responds to lactate.
6. The method of Claim 1, wherein reading an output from at least one of the implantable sensing elements comprises reading an output from an implantable sensing element that responds to blood oxygen saturation.
7. The method of Claim 1, wherein reading an output from at least one of the implantable sensing elements comprises reading an output from an implantable sensing element that responds to blood pressure.

8. The method of Claim 1, wherein reading an output from at least one of the implantable sensing elements comprises reading an output from an implantable sensing element that responds to glucose.
9. The method of Claim 1, wherein reading an output from at least one of the implantable sensing elements comprises reading an output from an implantable sensing element that responds to temperature.
10. The method of Claim 1, wherein reading an output from at least one of the implantable sensing elements comprises reading an output from an implantable sensing element that responds to potassium.
11. The method of Claim 1, wherein reading an output from at least one of the implantable sensing elements comprises reading an output from at least one implantable sensing element that responds to pH.
12. The method of Claim 1, further comprising administering therapy to the patient based on the output read from the at least one implantable sensing element.
13. The method of Claim 12, wherein administering therapy comprises administering therapy for myocardial ischemia.
14. The method of Claim 12, wherein administering therapy comprises administering therapy for myocardial infarction.
15. The method of Claim 12, wherein administering therapy comprises administering therapy for angina.
16. The method of Claim 12, wherein administering therapy comprises adjusting a function of an implantable cardiovascular defibrillator disposed within the patient.
17. The method of Claim 12, wherein administering therapy comprises adjusting a placement of an implantable cardiovascular defibrillator disposed within the patient.

18. The method of Claim 12, wherein administering therapy comprises administering therapy for sepsis.
19. The method of Claim 12, wherein administering therapy comprises administering therapy for septic shock.
20. The method of Claim 12, wherein administering therapy comprises administering therapy for a patient receiving extracorporeal membrane oxygenation.
21. The method of Claim 12, wherein administering therapy comprises administering therapy for a patient undergoing cardiac bypass.
22. The method of Claim 12, wherein administering therapy comprises administering therapy for a patient during dialysis.
23. The method of Claim 1, further comprising classifying a severity of a condition of the patient based on the output read from the at least one implantable sensing element.
24. The method of Claim 1, wherein the patient is in a surgical environment.
25. The method of Claim 1, wherein the patient is in an intensive care environment.
26. A method of evaluating a patient comprising:
 - implanting an implantable sensor in a patient, the implantable sensor having a housing within which are disposed a plurality of implantable sensing elements;
 - reading an output from at least one of the implantable sensing elements; and
 - evaluating the patient based on the output read from the at least one implantable sensing element,wherein a plurality of parameters are read from the implantable sensor at the single site, and
 - wherein the output read from at least one of the implantable sensing elements is a quantifiable value.
27. The method of Claim 26, wherein evaluating the patient comprises evaluating the patient based on an output from an implantable sensing element that responds to lactate.

28. The method of Claim 26, wherein evaluating the patient comprises evaluating the patient based on an output from an implantable sensing element that responds to blood oxygen saturation.
29. The method of Claim 26, wherein evaluating the patient comprises evaluating the patient based on an output from an implantable sensing element that responds to blood pressure.
30. The method of Claim 26, wherein evaluating the patient comprises evaluating the patient based on an output from an implantable sensing element that responds to glucose.
31. The method of Claim 26, wherein evaluating the patient comprises evaluating the patient based on an output from an implantable sensing element that responds to temperature.
32. The method of Claim 26, wherein evaluating the patient comprises evaluating the patient based on an output from an implantable sensing element that responds to potassium.
33. The method of Claim 26, wherein evaluating the patient comprises evaluating the patient based on an output from an implantable sensing element that responds to pH.
34. The method of Claim 26, wherein evaluating the patient comprises evaluating the patient for myocardial ischemia.
35. The method of Claim 26, wherein evaluating the patient comprises evaluating the patient for myocardial infarction.
36. The method of Claim 26, wherein evaluating the patient comprises evaluating the patient for angina.
37. The method of Claim 26, wherein evaluating the patient comprises evaluating the patient having an implantable cardiovascular defibrillator.

38. The method of Claim 26, wherein evaluating the patient comprises evaluating the patient for sepsis.
39. The method of Claim 26, wherein evaluating the patient comprises evaluating the patient receiving extracorporeal membrane oxygenation.
40. The method of Claim 26, wherein evaluating the patient comprises evaluating the patient undergoing cardiac bypass.
41. The method of Claim 26, wherein evaluating the patient comprises evaluating the patient during dialysis.
42. A method of sensing multiple parameters in a triage patient comprising:
implanting an implantable sensor at a single site in the triage patient, the implantable sensor having a housing within which are disposed a plurality of implantable sensing elements; and
reading an output from at least one of the implantable sensing elements,
wherein a plurality of parameters are read from the implantable sensor at the single site, and
wherein the output read from at least one of the implantable sensing elements is a quantifiable value.
43. A method of sensing multiple parameters in field applications comprising:
implanting an implantable sensor at a single site in a patient in the field, the implantable sensor having a housing within which are disposed a plurality of implantable sensing elements; and
reading an output from at least one of the implantable sensing elements,
wherein a plurality of parameters are read from the implantable sensor at the single site, and
wherein the output read from at least one of the implantable sensing elements is a quantifiable value.

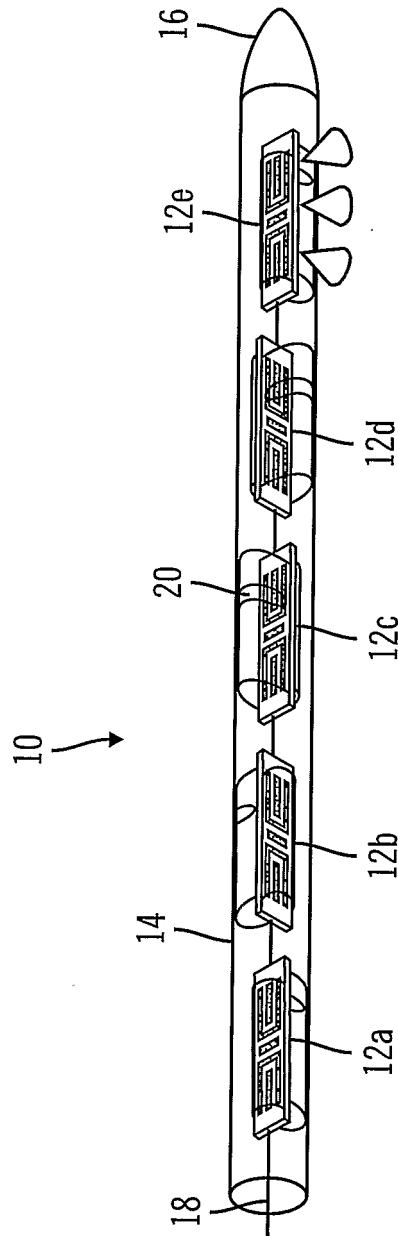

FIG. 1

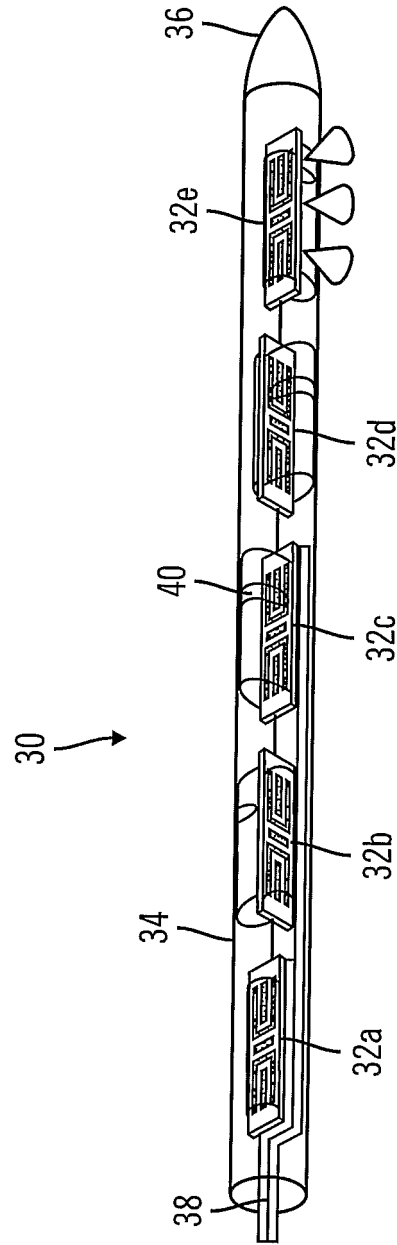

FIG. 2

3/11

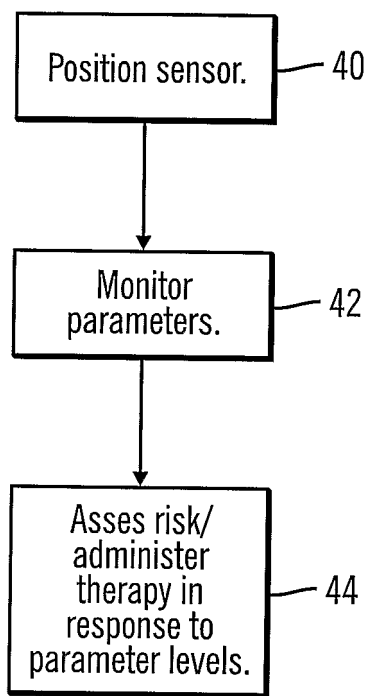

FIG. 3

4/11

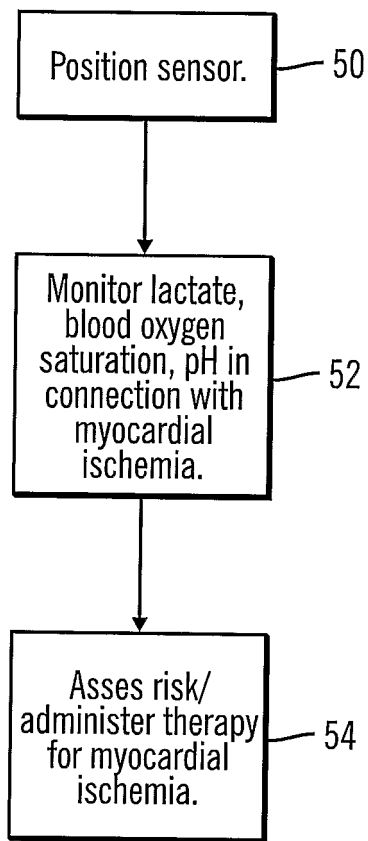

FIG. 4

5/11

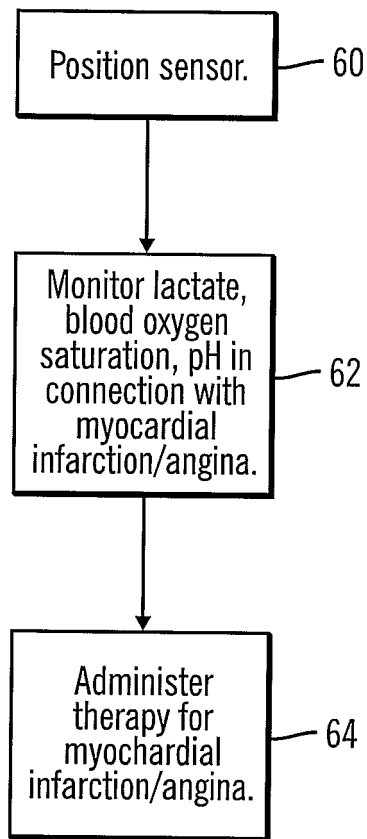

FIG. 5

6/11

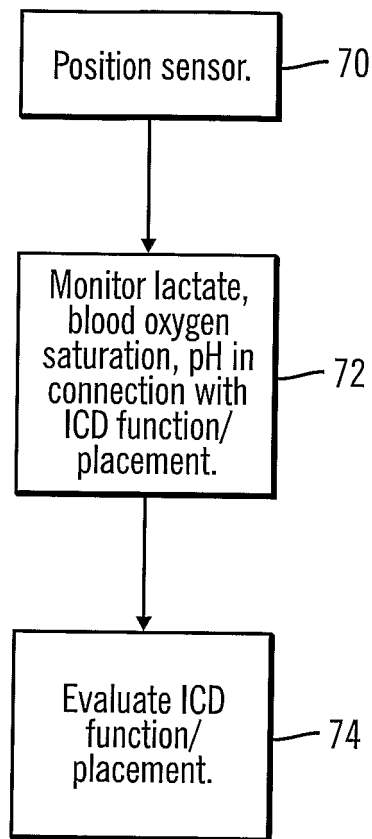

FIG. 6

7/11

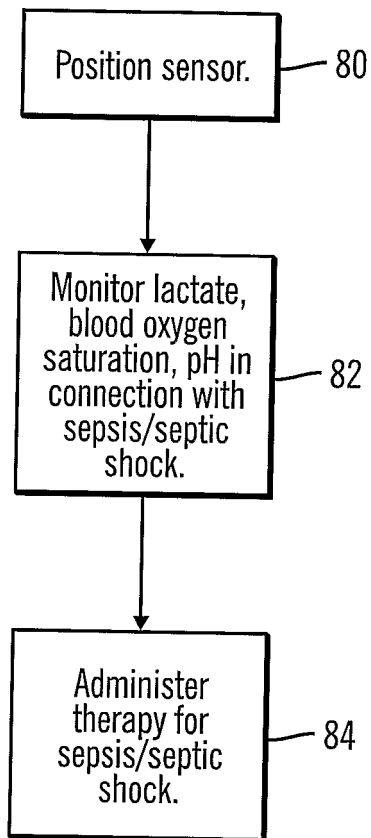

FIG. 7

8/11

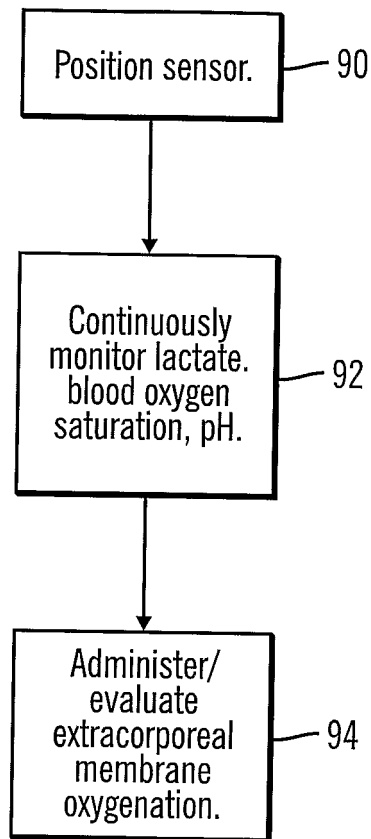

FIG. 8

9/11

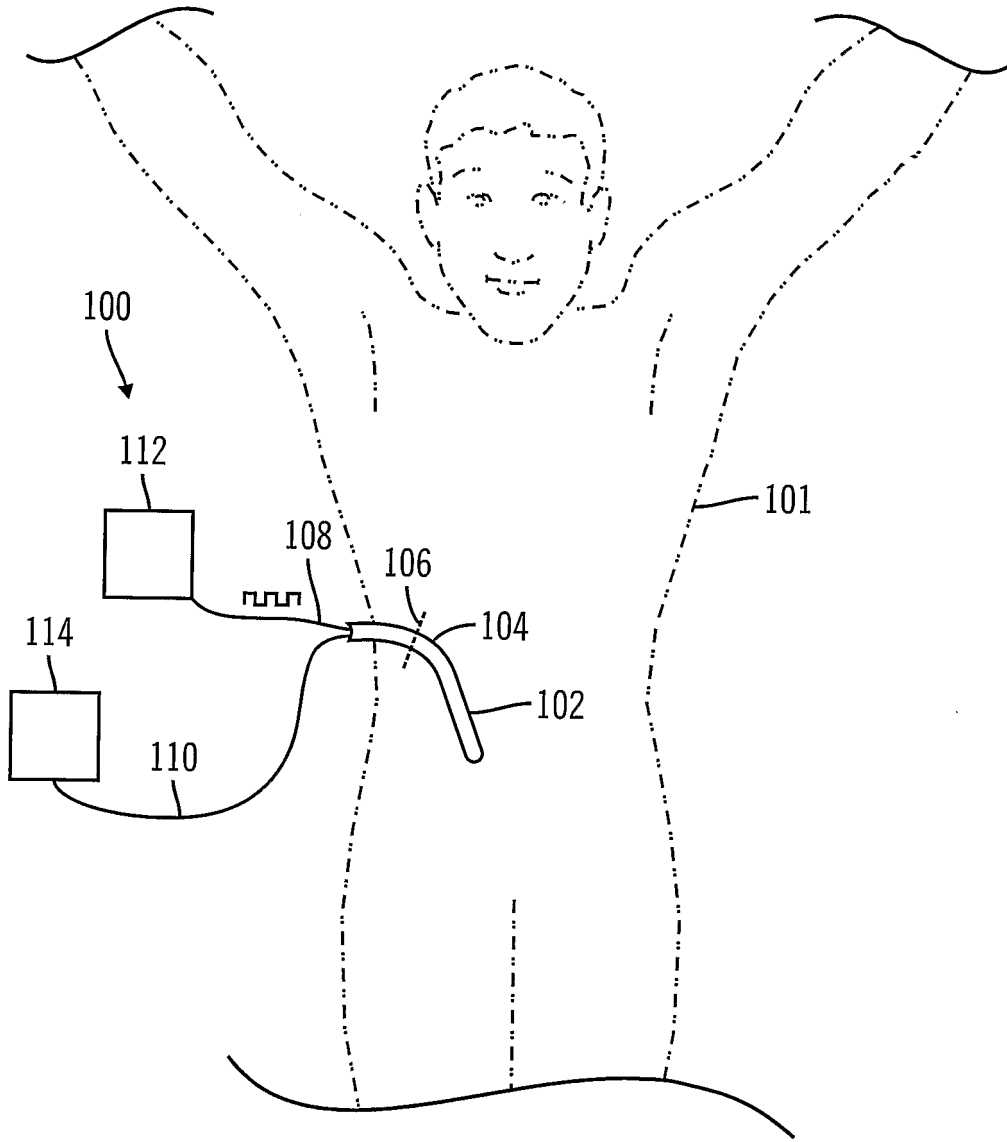

FIG. 9

10/11

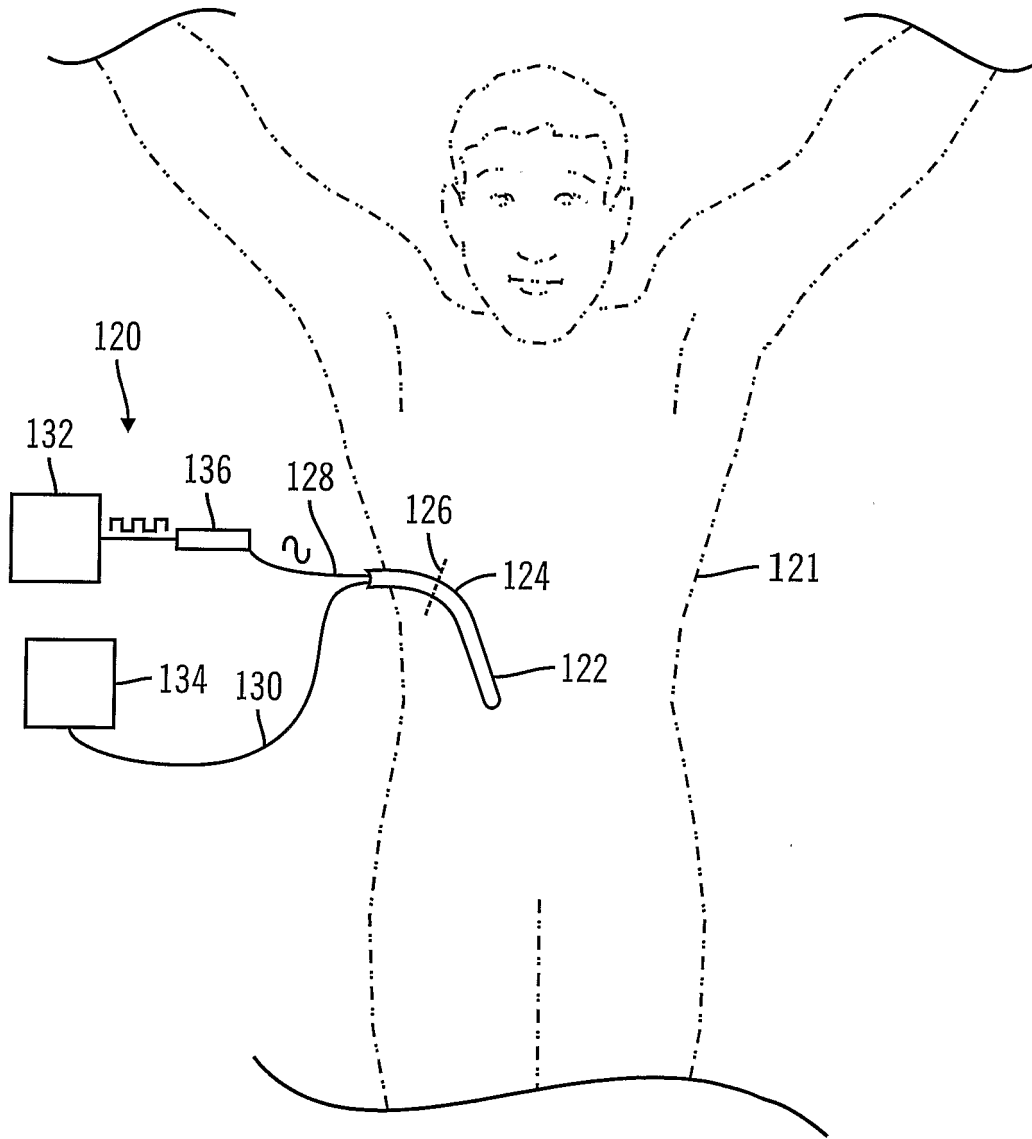

FIG. 10

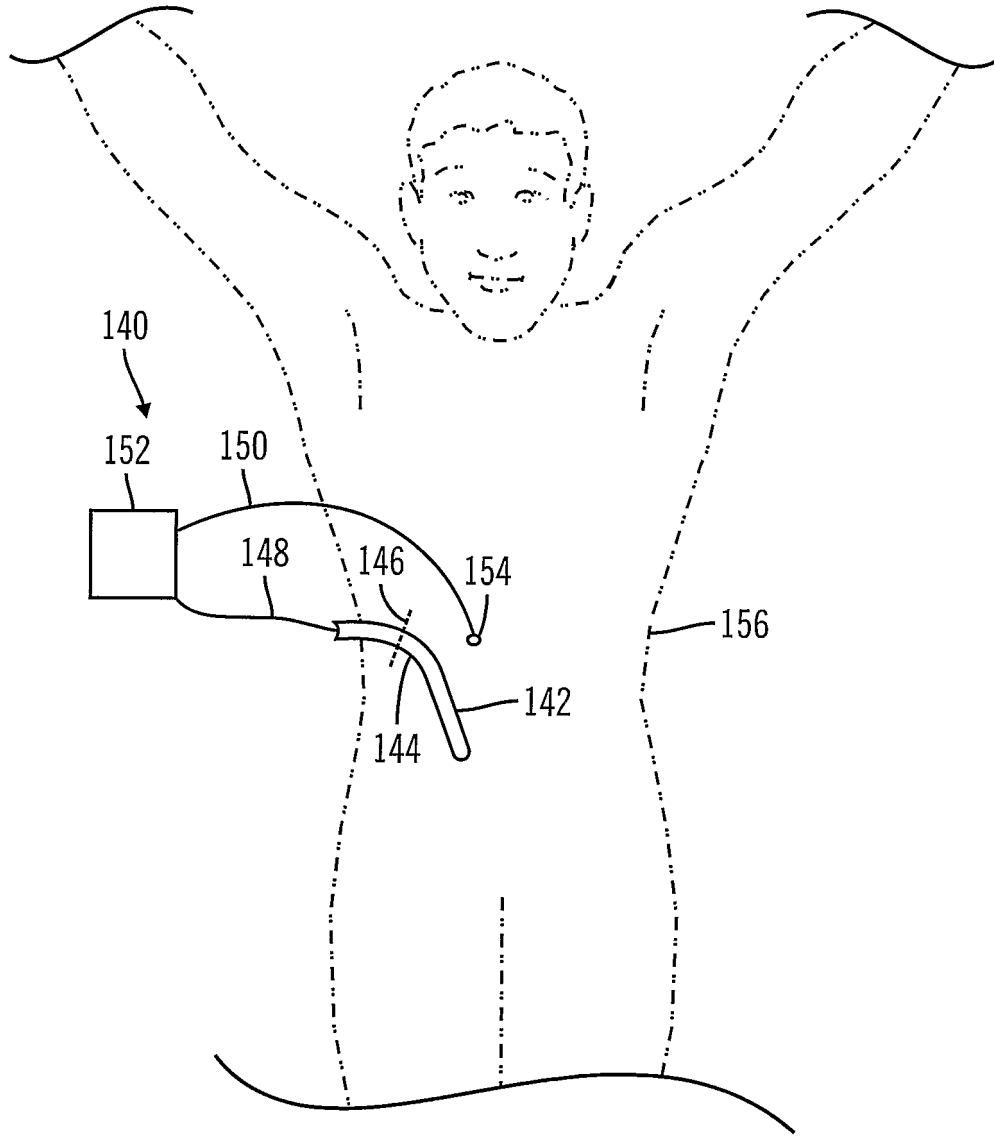

FIG. 11

PATENT COOPERATION TREATY

PCT

DECLARATION OF NON-ESTABLISHMENT OF INTERNATIONAL SEARCH REPORT

(PCT Article 17(2)(a), Rules 13ter.1(c) and Rule 39)

Applicant's or agent's file reference 047711-5145	IMPORTANT DECLARATION	Date of mailing(day/month/year) 14/12/2004
International application No. PCT/US2004/028505	International filing date(day/month/year) 02/09/2004	(Earliest) Priority date(day/month/year) 23/09/2003
International Patent Classification (IPC) or both national classification and IPC G01N33/50		
Applicant MEDTRONIC MINIMED, INC.		

This International Searching Authority hereby declares, according to Article 17(2)(a), that **no international search report will be established** on the international application for the reasons indicated below

1. The subject matter of the international application relates to:
 - a. scientific theories.
 - b. mathematical theories
 - c. plant varieties.
 - d. animal varieties.
 - e. essentially biological processes for the production of plants and animals, other than microbiological processes and the products of such processes.
 - f. schemes, rules or methods of doing business.
 - g. schemes, rules or methods of performing purely mental acts.
 - h. schemes, rules or methods of playing games.
 - i. methods for treatment of the human body by surgery or therapy.
 - j. methods for treatment of the animal body by surgery or therapy.
 - k. diagnostic methods practised on the human or animal body.
 - l. mere presentations of information.
 - m. computer programs for which this International Searching Authority is not equipped to search prior art.
2. The failure of the following parts of the international application to comply with prescribed requirements prevents a meaningful search from being carried out:

<input type="checkbox"/> the description	<input checked="" type="checkbox"/> the claims	<input type="checkbox"/> the drawings
--	--	---------------------------------------
3. The failure of the nucleotide and/or amino acid sequence listing to comply with the standard provided for in Annex C of the Administrative Instructions prevents a meaningful search from being carried out:

<input type="checkbox"/> the written form has not been furnished or does not comply with the standard.
<input type="checkbox"/> the computer readable form has not been furnished or does not comply with the standard.
4. The failure of the tables related to the nucleotide and/or amino acid sequence listing to comply with the technical requirements provided for in Annex C-bis of the Administrative Instructions prevents a meaningful search from being carried out:

<input type="checkbox"/> the written form has not been furnished.
<input type="checkbox"/> the computer readable form has not been furnished or does not comply with the technical requirements.
5. Further comments:

Name and mailing address of the International Searching Authority  European Patent Office, P.B. 5818 Patentlaan 2 NL-2280 HV Rijswijk Tel (+31-70) 340-2040, Tx. 31 651 epo nl, Fax: (+31-70) 340-3016	Authorized officer Eva San Miguel
---	--

FURTHER INFORMATION CONTINUED FROM PCT/ISA/ 203

A meaningful search is not possible on the basis of any of the claims because all claims are directed to a method for treatment of the human or animal body by surgery - Rule 39.1(iv) PCT: All claimed methods involve the surgical step of implanting a sensor in a patient. A single surgical step renders the entire method surgical in the sense of Rule 39.1(iv) PCT.

The applicant's attention is drawn to the fact that claims relating to inventions in respect of which no international search report has been established need not be the subject of an international preliminary examination (Rule 66.1(e) PCT). The applicant is advised that the EPO policy when acting as an International Preliminary Examining Authority is normally not to carry out a preliminary examination on matter which has not been searched. This is the case irrespective of whether or not the claims are amended following receipt of the search report or during any Chapter II procedure. If the application proceeds into the regional phase before the EPO, the applicant is reminded that a search may be carried out during examination before the EPO (see EPO Guideline C-VI, 8.5), should the problems which led to the Article 17(2) declaration be overcome.

专利名称(译)	可植入的多参数传感系统和方法		
公开(公告)号	EP1680676A1	公开(公告)日	2006-07-19
申请号	EP2004782904	申请日	2004-09-02
[标]申请(专利权)人(译)	美敦力迷你迈德公司		
申请(专利权)人(译)	MEDTRONIC MINIMED INC.		
当前申请(专利权)人(译)	MEDTRONIC MINIMED INC.		
[标]发明人	SHAH RAJIV REGHABI BAHAR GOTTLIEB REBECCA ENEGREN BRADLEY J		
发明人	SHAH, RAJIV REGHABI, BAHAR GOTTLIEB, REBECCA ENEGREN, BRADLEY, J.		
IPC分类号	G01N33/50 A61B5/0205 A61B5/00 A61B5/0215		
CPC分类号	A61B5/6852 A61B5/02055 A61B5/0215 A61B5/14532 A61B5/14539 A61B5/14546 A61B5/1473 A61B5/412 A61B5/7275		
优先权	10/669426 2003-09-23 US		
其他公开文献	EP1680676B1		
外部链接	Espacenet		

摘要(译)

一种感测多个参数的系统和方法。该方法可以包括将可植入传感器植入患者体内并从至少一个可植入传感元件读取输出。可植入传感器可以具有壳体，多个可植入传感元件设置在壳体内。至少一个可植入传感元件可响应乳酸。另外，医学专业人员可以根据输出读数向患者施用心肌缺血，心肌梗塞性心绞痛，败血症。医疗专业人员还可以向患者施用具有可植入心血管除颤器或正在接受体外膜氧合作用的患者。该方法可用于外科或重症监护环境。