



(12) **EUROPEAN PATENT APPLICATION**

(43) Date of publication:
27.09.2017 Bulletin 2017/39

(51) Int Cl.:
A61B 5/00 (2006.01) A61B 5/04 (2006.01)
A61B 5/0205 (2006.01) A61B 5/024 (2006.01)
A61B 5/0245 (2006.01) A61B 5/0402 (2006.01)
A61B 5/0476 (2006.01) A61B 5/08 (2006.01)

(21) Application number: **17169569.5**

(22) Date of filing: **25.07.2012**

(84) Designated Contracting States:
AL AT BE BG CH CY CZ DE DK EE ES FI FR GB GR HR HU IE IS IT LI LT LU LV MC MK MT NL NO PL PT RO RS SE SI SK SM TR

(72) Inventor: **ROMESBURG, Eric Douglas**
Chapel Hill, NC 27516 (US)

(30) Priority: **02.08.2011 US 201161514099 P**

(74) Representative: **Yeadon IP Limited**
Leeds Innovation Centre
103 Clarendon Road
Leeds LS2 9DF (GB)

(62) Document number(s) of the earlier application(s) in accordance with Art. 76 EPC:
12820308.0 / 2 739 207

Remarks:
This application was filed on 04.05.2017 as a divisional application to the application mentioned under INID code 62.

(71) Applicant: **Valencell, Inc.**
Raleigh, NC 27609 (US)

(54) **SYSTEMS AND METHODS FOR VARIABLE FILTER ADJUSTMENT BY HEART RATE METRIC FEEDBACK**

(57) A physiological signal processing system for a physiological waveform that includes a cardiovascular signal component provides a variable high pass filter that is responsive to the physiological waveform, and that is configured to high pass filter the physiological waveform in response to a corner frequency that is applied. A heart rate metric extractor is responsive to the variable high

pass filter and is configured to extract a heart rate metric from the physiological waveform that is high pass filtered. A corner frequency adjuster is responsive to the heart rate metric extractor and is configured to determine the corner frequency that is applied to the variable high pass filter, based on the heart rate metric that was extracted. Analogous methods may also be provided.

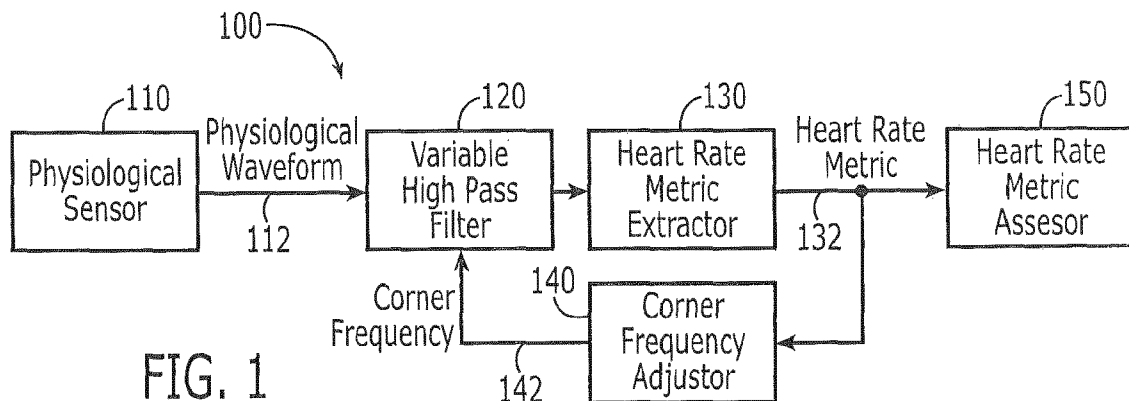

FIG. 1

Description

CROSS REFERENCE TO RELATED APPLICATION

5 **[0001]** This application claims the benefit of provisional Patent Application No. 61/514,099, filed August 2, 2011, entitled *Systems and Methods for Variable Filter Adjustment by Physiological Metric Feedback*, assigned to the assignee of the present invention, the disclosure of which is hereby incorporated herein by reference in their entirety as if set forth fully herein.

10 BACKGROUND

[0002] Various embodiments described herein relate generally to signal processing systems and methods, and more particularly to physiological signal processing systems and methods.

15 **[0003]** There is a growing market demand for personal health and environmental monitors, for example, for gauging overall health, fitness, metabolism, and vital status during exercise, athletic training, work, public safety activities, dieting, daily life activities, sickness and physical therapy. These personal health and environmental monitors process physiological signals that may be obtained from one or more physiological sensors, and are configured to extract one or more physiological metrics from physiological waveforms. Unfortunately, inaccurate physiological metric extraction can reduce the accuracy of health, fitness and/or vital status monitoring.

20

SUMMARY

[0004] It should be appreciated that this Summary is provided to introduce a selection of concepts in a simplified form, the concepts being further described below in the Detailed Description. This Summary is not intended to identify key features or essential features of this disclosure, nor is it intended to limit the scope of the invention.

25

[0005] Various embodiments described herein can provide physiological signal processing systems for physiological waveforms that include cardiovascular signal components therein. These physiological signal processing systems may include a variable high pass filter that is responsive to the physiological waveform and that is configured to high pass filter the physiological waveform in response to a corner frequency that is applied thereto. A heart rate metric extractor is responsive to the variable high pass filter and is configured to extract a heart rate metric from the physiological waveform that is high pass filtered. A corner frequency adjustor is responsive to the heart rate metric extractor and is configured to determine the corner frequency that is applied to the variable high pass filter, based on the heart rate metric that was extracted. A physiological metric assessor may also be provided that is responsive to the heart rate metric extractor and that is configured to process the heart rate metric to generate at least one physiological assessment.

30

35 **[0006]** Physiological waveforms may be processed according to various embodiments described herein. For example, the physiological waveform may include an electroencephalogram (EEG), an electrocardiogram (ECG) and/or a radio frequency (RF) waveform, an electro-optical physiological waveform including a photoplethysmograph (PPG) waveform, an electro-photoacoustic waveform including a photoacoustic waveform, an electro-mechanical physiological waveform including an auscultation waveform, a piezo sensor waveform and/or an accelerometer waveform, and/or an electro-nuclear physiological waveform. Moreover, various physiological assessments may be provided including ventilator threshold, lactate threshold, cardiopulmonary status, neurological status, aerobic capacity (VO_2 max) and/or overall health or fitness.

40

[0007] Various configurations of variable high pass filters may also be provided according to various embodiments described herein. For example, the variable high pass filter may comprise a single high pass filter having an adjustable corner frequency, wherein the corner frequency adjustor is configured to determine the adjustable corner frequency. Alternatively, the variable high pass filter may comprise a plurality of high pass filters, a respective one of which includes a different value of the corner frequency, wherein the corner frequency adjustor is configured to select one of the plurality of high pass filters that corresponds to the corner frequency that is determined.

45

[0008] Various other embodiments of variable high pass filters may also be provided. Analog variable high pass filters may be provided with adjustable component values thereof. Alternatively, the variable high pass filter may comprise a variable digital high pass filter having a plurality of delay taps, wherein the corner frequency corresponds to a number of the plurality of delay taps that are selected to filter the physiological waveform. In these embodiments, the corner frequency adjustor may comprise a mapping system that is configured to map the heart rate metric that is extracted from the physiological waveform that is filtered into the number of the delay taps that are selected to high pass filter the physiological waveform.

50

55 **[0009]** Various embodiments described herein can also configure the corner frequency adjustor to reduce or prevent locking on an erroneous heart rate metric. In some embodiments, the corner frequency adjustor is configured to initially set a predetermined corner frequency corresponding to a predetermined heart rate prior to determining the corner

frequency that is applied to the variable high pass filter from the heart rate metric. The predetermined heart rate may be a resting heart rate, such as 72 beats per minute. The corner frequency adjuster may also be configured to initially set the predetermined corner frequency corresponding to the predetermined heart rate until the heart rate metric extractor locks on a heart rate of the physiological waveform. Moreover, the corner frequency adjuster may also be configured to reset or reapply the predetermined corner frequency corresponding to the predetermined heart rate in response to determining that the physiological sensor is no longer responsive to a source of the physiological waveform. The corner frequency adjuster may also be configured to determine the at least one corner frequency that is applied to the variable high pass filter from the heart rate metric by applying a margin to the heart rate metric. Moreover, the variable high pass filter may include a gradual filter transition band (i.e., it is not a brick wall filter).

[0010] Various embodiments described herein may also provide physiological signal processing systems that may be used with physiological sensors that are configured to generate a physiological waveform that includes cardiovascular and pulmonary signal components therein. A variable high pass filter and a variable low pass filter are provided that are responsive to the physiological waveform and that are configured to high pass and low pass filter, respectively, the physiological waveform in response to at least one corner frequency that is applied thereto. A heart rate metric extractor is provided that is responsive to the variable high pass filter and that is configured to extract a heart rate metric from the physiological waveform that is filtered by the variable high pass filter. A respiration rate metric extractor is provided that is responsive to the variable low pass filter and that is configured to extract a respiration rate metric from the physiological waveform that is filtered by the variable low pass filter. A corner frequency adjuster is also provided that is responsive to the heart rate metric extractor and that is configured to determine the at least one corner frequency that is applied to the variable high pass filter and the variable low pass filter from the heart rate metric.

[0011] The variable high pass and the variable low pass filter may respectively comprise a single high pass and a single low pass filter having an adjustable corner frequency, and the corner frequency adjuster may be configured to determine the adjustable corner frequency for the single high pass filter and the single low pass filter. Alternatively, the variable high pass filter and the variable low pass filter may respectively comprise a plurality of high pass filters and a plurality of low pass filters, a respective one of which includes a different corner frequency, and the corner frequency adjuster may be configured to select one of the plurality of high pass filters and one of the plurality of low pass filters that corresponds to the at least one corner frequency that is determined by the corner frequency adjuster.

[0012] Moreover, in some embodiments, the variable high pass filter and the variable low pass filter comprise a variable digital high pass filter and a variable digital low pass filter having a plurality of high pass and low pass delay taps, respectively, and the corner frequency is determined by a number of the high pass and low pass delay taps that are selected to filter the physiological waveform.

[0013] The corner frequency adjuster may also comprise a mapping system that is configured to map the heart rate metric that is extracted from the physiological waveform that is filtered into the number of the delay taps that are selected to filter the physiological waveform. The mapping system may be configured to determine a corner frequency of the variable low pass filter and the variable high pass filter by determining a maximum of a minimum heart rate and the heart rate metric minus a margin, and may be further configured to determine the number of delay taps by rounding a product of the delay of the delay taps and the minimum heart rate divided by the corner frequency that was determined. Moreover, the mapping system may be configured to determine a corner frequency of the variable low pass filter and the variable high pass filter by applying a margin to the heart rate metric, and may be further configured to determine the number of delay taps from the corner frequency that was determined.

[0014] Various embodiments described herein can also configure the corner frequency adjuster to reduce or prevent locking on an erroneous heart rate metric. In some embodiments, the corner frequency adjuster is configured to initially set at least one predetermined corner frequency corresponding to a predetermined heart rate prior to determining the at least one corner frequency that is applied to the variable high pass filter and the variable low pass filter from the heart rate metric. The predetermined heart rate may be a resting heart rate, such as 72 beats per minute. The corner frequency adjuster may be configured to initially set the at least one predetermined corner frequency corresponding to the predetermined heart rate until the heart rate metric extractor locks on a heart rate in the physiological waveform. The corner frequency may also be configured to reset or reapply the at least one predetermined corner frequency corresponding to the predetermined heart rate in response to determining that the physiological sensor is no longer responsive to a source of the physiological waveform. The corner frequency adjuster may be configured to determine the corner frequency that is applied to the variable high pass filter and the variable low pass filter from the heart rate metric by applying a margin to the heart rate metric. Moreover, the variable high pass filter may include a gradual filter transition band (i.e., it is not a brick wall filter).

[0015] In any of the embodiments described herein, the corner frequency adjuster may include hysteresis to reduce or prevent excessive filter adjustment. Moreover, in any of these embodiments, the at least one corner frequency may comprise a same corner frequency that is applied to the variable high pass and low pass filters. Finally, in any of these embodiments, the sensor may be a plethysmograph sensor and, more specifically, a photoplethysmograph sensor.

[0016] Various embodiments have been described above in connection with physiological signal processing systems.

However, analogous physiological signal processing methods may also be provided according to various embodiments described herein. For example, some embodiments described herein can provide a physiological signal processing method comprising high pass filtering the physiological waveform in response to an adjustable high pass filter corner frequency, extracting a heart rate metric from the physiological waveform that is high pass filtered and determining the adjustable high pass filter corner frequency that is applied to the high pass filtering, from the heart rate that was extracted. Moreover, the determining may be provided by selecting one of a plurality of high pass filters that corresponds to the high pass filter corner frequency that is determined, or determining a number of a plurality of delay taps that are selected in the filtering. Other embodiments corresponding to the above described system embodiments also may be provided.

[0017] Yet other embodiments of physiological signal processing methods comprise obtaining a physiological waveform that includes cardiovascular and pulmonary signal components therein, variable high pass and low pass filtering the physiological waveform in response to at least one corner frequency, extracting a heart rate metric from the physiological waveform that is filtered by the variable high pass filtering, extracting a respiration rate metric from the physiological waveform that is filtered by the variable low pass filtering, and determining the at least one corner frequency that is applied to the variable high pass and low pass filtering from the heart rate metric that was extracted. Again, the determining may comprise adjusting the corner frequency for the variable high pass and low pass filtering, for example by selecting one of a plurality of high pass and low pass filters that corresponds to at least one corner frequency that is determined and/or determining a number of a plurality of high pass and low pass delay taps that are selected by the variable high pass and low pass filtering. Specifically, the heart rate metric may be mapped into the number of delay taps. This may be embodied, for example, by determining a corner frequency of the variable low pass and the variable high pass filtering by applying a margin to the heart rate metric and determining the number of delay taps from the corner frequency. Other embodiments corresponding to the above described system embodiments may also be provided.

BRIEF DESCRIPTION OF THE DRAWINGS

[0018]

Figures 1-4 are functional block diagrams of physiological signal processing systems and methods according to various embodiments described herein.

Figure 5 is a functional block diagram of a digital variable high pass filter according to various embodiments described herein.

Figure 6 is a functional block diagram of a digital variable low pass filter according to various embodiments described herein.

Figure 7 is a flowchart of operations that may be performed by a corner frequency adjuster according to various embodiments described herein.

Figure 8 graphically illustrates adjusting a corner frequency of a variable high pass filter according to various embodiments described herein.

Figure 9 graphically illustrates adjusting a corner frequency of a variable low pass filter according to various embodiments described herein.

Figures 10-15 illustrate measured waveforms according to various embodiments described herein.

DETAILED DESCRIPTION

[0019] The present invention will now be described more fully hereinafter with reference to the accompanying figures, in which various embodiments are shown. This invention may, however, be embodied in many different forms and should not be construed as limited to the embodiments set forth herein. Like numbers refer to like elements throughout. The sequence of operations (or steps) is not limited to the order presented in the figures and/or claims unless specifically indicated otherwise. Features described with respect to one figure or embodiment can be associated with another embodiment or figure although not specifically described or shown as such.

[0020] It will be understood that, when a feature or element is referred to as being "connected", "attached", "coupled" or "responsive" to another feature or element, it can be directly connected, attached, coupled or responsive to the other feature or element or intervening features or elements may be present. In contrast, when a feature or element is referred to as being "directly connected", "directly attached", "directly coupled" or "directly responsive" to another feature or element, there are no intervening features or elements present.

[0021] The terminology used herein is for the purpose of describing particular embodiments only and is not intended to be limiting of the invention. As used herein, the singular forms "a", "an" and "the" are intended to include the plural forms as well, unless the context clearly indicates otherwise. It will be further understood that the terms "comprises" and/or "comprising," when used in this specification, specify the presence of stated features, steps, operations, elements, and/or components, but do not preclude the presence or addition of one or more other features, steps, operations,

elements, components, and/or groups thereof. As used herein, the term "and/or" includes any and all combinations of one or more of the associated listed items.

5 [0022] It will be understood that although the terms first and second are used herein to describe various features/elements, these features/elements should not be limited by these terms. These terms are only used to distinguish one feature/element from another feature/element. Thus, a first feature/element discussed below could be termed a second feature/element, and similarly, a second feature/element discussed below could be termed a first feature/element without departing from the teachings of the present invention.

10 [0023] Unless otherwise defined, all terms (including technical and scientific terms) used herein have the same meaning as commonly understood by one of ordinary skill in the art to which this invention belongs. It will be further understood that terms, such as those defined in commonly used dictionaries, should be interpreted as having a meaning that is consistent with their meaning in the context of the specification and relevant art and should not be interpreted in an idealized or overly formal sense unless expressly so defined herein. Well-known functions or constructions may not be described in detail for brevity and/or clarity.

15 [0024] The term "headset" includes any type of device or earpiece that may be attached to or near the ear (or ears) of a user and may have various configurations, without limitation. Headsets as described herein may include mono headsets (one earbud) and stereo headsets (two earbuds), earbuds, hearing aids, ear jewelry, face masks, headbands, and the like.

20 [0025] The term "real-time" is used to describe a process of sensing, processing, or transmitting information in a time frame which is equal to or shorter than the minimum timescale at which the information is needed. For example, the real-time monitoring of pulse rate may result in a single average pulse-rate measurement every minute, averaged over 30 seconds, because an instantaneous pulse rate is often useless to the end user. Typically, averaged physiological and environmental information is more relevant than instantaneous changes. Thus, in the context of embodiments of the present invention, signals may sometimes be processed over several seconds, or even minutes, in order to generate a "real-time" response.

25 [0026] The term "monitoring" refers to the act of measuring, quantifying, qualifying, estimating, sensing, calculating, interpolating, extrapolating, inferring, deducing, or any combination of these actions. More generally, "monitoring" refers to a way of getting information via one or more sensing elements. For example, "blood health monitoring" includes monitoring blood gas levels, blood hydration, and metabolite/electrolyte levels.

30 [0027] The term "physiological" refers to matter or energy of or from the body of a creature (e.g., humans, animals, etc.). In embodiments of the present invention, the term "physiological" is intended to be used broadly, covering both physical and psychological matter and energy of or from the body of a creature. However, in some cases, the term "psychological" is called-out separately to emphasize aspects of physiology that are more closely tied to conscious or subconscious brain activity rather than the activity of other organs, tissues, or cells.

35 [0028] The term "body" refers to the body of a subject (human or animal) who may wear a headset incorporating embodiments of the present invention.

[0029] In the included figures, various embodiments will be illustrated and described. However, it is to be understood that embodiments of the present invention are not limited to those worn by humans.

40 [0030] The ear is an ideal location for wearable health and environmental monitors. The ear is a relatively immobile platform that does not obstruct a person's movement or vision. Headsets located at an ear have, for example, access to the inner-ear canal and tympanic membrane (for measuring core body temperature), muscle tissue (for monitoring muscle tension), the pinna and earlobe (for monitoring blood gas levels), the region behind the ear (for measuring skin temperature and galvanic skin response), and the internal carotid artery (for measuring cardiopulmonary functioning), etc. The ear is also at or near the point of exposure to: environmental breathable toxicants of interest (volatile organic compounds, pollution, etc.); noise pollution experienced by the ear; and lighting conditions for the eye. Furthermore, as the ear canal is naturally designed for transmitting acoustical energy, the ear provides a good location for monitoring internal sounds, such as heartbeat, breathing rate, and mouth motion.

45 [0031] Wireless, Bluetooth®-enabled, and/or other personal communication headsets may be configured to incorporate physiological and/or environmental sensors, according to some embodiments of the present invention. As a specific example, Bluetooth® headsets are typically lightweight, unobtrusive devices that have become widely accepted socially. Moreover, Bluetooth® headsets are cost effective, easy to use, and are often worn by users for most of their waking hours while attending or waiting for cell phone calls. Bluetooth® headsets configured according to embodiments of the present invention are advantageous because they provide a function for the user beyond health monitoring, such as personal communication and multimedia applications, thereby encouraging user compliance. Exemplary physiological and environmental sensors that may be incorporated into a Bluetooth® or other type of headsets include, but are not limited to accelerometers, auscultatory sensors, pressure sensors, humidity sensors, color sensors, light intensity sensors, pressure sensors, etc.

55 [0032] Optical coupling into the blood vessels of the ear may vary between individuals. As used herein, the term "coupling" refers to the interaction or communication between excitation light entering a region and the region itself. For

example, one form of optical coupling may be the interaction between excitation light generated from within a light-guiding earbud and the blood vessels of the ear. Light guiding earbuds are described in co-pending U.S. Patent Application Publication No. 2010/0217102, which is incorporated herein by reference in its entirety. In one embodiment, this interaction may involve excitation light entering the ear region and scattering from a blood vessel in the ear such that the intensity of scattered light is proportional to blood flow within the blood vessel. Another form of optical coupling may be the interaction between excitation light generated by an optical emitter within an earbud and the light-guiding region of the earbud.

[0033] Various embodiments described herein are not limited to headsets that communicate wirelessly. In some embodiments of the present invention, headsets configured to monitor an individual's physiology and/or environment may be wired to a device that stores and/or processes data. In some embodiments, this information may be stored on the headset itself. Furthermore, various embodiments described herein are not limited to earbuds. Some embodiments may be employed around another part of the body, such as a digit, finger, toe, limb, wrist, around the nose or earlobe, or the like. Other embodiments may be integrated into a patch, such as a bandage that sticks on a person's body.

[0034] Various embodiments described herein may arise from recognition that a physiological signal component in a physiological waveform may change dramatically over time, for example due to the user's activity level and/or other factors. In order to effectively extract a physiological metric from the physiological waveform, the physiological metric itself may be used to directly or indirectly adjust a parameter of a variable filter, such as a filter's low pass or high pass corner frequency. Accordingly, accurate filtering may be provided and accurate parameter extraction may be obtained, notwithstanding the large changes that may take place in the value of the physiological metric.

[0035] It also may be exceedingly difficult to extract metrics from physiological sensors that generate physiological waveforms that include multiple physiological signal components therein. For example, a physiological sensor, such as a plethysmograph or a photoplethysmograph, may include cardiovascular and pulmonary signal components therein. Unfortunately, these physiological metrics have overlapping frequency ranges. For example, the cardiovascular signal component (heart rate) may range from about 45 beats per minute to about 220 beats per minute, while the pulmonary signal component (respiration rate) may range from about 12 breaths per minute to about 70 breaths per minute. Due to the overlap, it may be exceedingly difficult to separate the two physiological components.

[0036] However, various embodiments described herein may arise from further recognition that, in general, although heart rate and respiration rate may overlap, their rise and fall may generally track due to, for example, changes in physical activity or the environment. Thus, they may both generally go up together and go down together. Accordingly, various embodiments described herein can provide a variable high pass and a variable low pass filter having at least one corner frequency that can be varied in response to a heart rate metric that is extracted from the high pass filtered physiological waveform. By providing variable filter adjustment using physiological metric feedback, the heart and/or respiration rate may be extracted accurately, notwithstanding the fact that they are contained in the same signal and overlap in their frequency ranges.

[0037] Various embodiments described herein may also arise from recognition that it did not appear to be heretofore possible to use an extracted heart rate to control a high pass filter that feeds a heart rate metric extractor. Specifically, due to the possibility for the extracted heart rate to be in error, the high pass filter may blind the metric extractor from the heart rate frequency in the physiological waveform signal. In other words, the heart rate metric extractor may get stuck at a high rate and, due to the high pass filtering that takes place, may never become responsive to the heart rate in the physiological waveform. Accordingly, the heart rate metric extractor may diverge or run away from the actual heart rate. Yet, despite these potential problems, various embodiments described herein can allow an extracted heart rate metric to be used to set a variable high pass filter corner frequency, and in some embodiments to also set a variable low pass filter corner frequency, while reducing or eliminating the heart rate extractor from being blinded to its own frequency.

[0038] Accordingly, various embodiments described herein can reduce or prevent locking on an erroneous heart rate metric. Thus, a heart rate metric can be used to set a corner frequency of a variable high pass filter for heart rate extraction. Moreover, the heart rate metric that is extracted may also be used to set a corner frequency for a variable low pass filter for respiration rate extraction, according to various embodiments described herein.

[0039] Figure 1 is a functional block diagram of physiological signal processing systems and methods according to various embodiments described herein. Referring now to Figure 1, these physiological signal processing systems/methods **100** may be used to process a physiological waveform **112** that is produced by a physiological sensor **110**, and that includes a physiological signal component therein. The physiological waveform **112** may include an electrical physiological waveform including an electroencephalogram (EEG), an electrocardiogram (ECG) and/or a radio frequency (RF) waveform, an electro-optical physiological waveform including a photoplethysmograph (PPG) waveform, an electro-photoacoustic waveform including a photoacoustic waveform, an electro-mechanical physiological waveform including an auscultation waveform, a piezo sensor waveform and/or an accelerometer waveform, and/or an electro-nuclear physiological waveform. The physiological signal component may include a neurological, cardiovascular and/or pulmonary signal component. For example, in some embodiments, the physiological sensor **110** may be a plethysmograph

sensor, such as a photoplethysmograph (PPG) sensor, and the physiological waveform may include both cardiovascular and pulmonary signal components therein.

[0040] Still referring to Figure 1, a heart rate metric extractor **130** extracts a heart rate metric **132** from the physiological waveform **112**. The heart rate metric extractor **130** may extract the heart rate metric using one or more conventional techniques. Moreover, a heart rate metric assessor **150** may be provided to assess the heart rate metric according to one or many known physiological metric assessment techniques. The physiological assessment may include ventilator threshold, lactate threshold, cardiopulmonary status, neurological status, aerobic capacity (VO₂ max) and/or overall health or fitness.

[0041] Still referring to Figure 1, the heart rate metric extractor **130** is coupled to the physiological sensor **110** by a variable high pass filter **120**. The variable high pass filter **120** is responsive to the physiological sensor **110**, and is configured to high pass filter the physiological waveform **112** in response to a corner frequency **142** that is applied thereto. The high pass filter **120** may include a single analog or digital high pass filter having an adjustable corner frequency **142**. Alternatively, the variable high pass filter **120** may comprise a plurality of analog or digital high pass filters, a respective one of which includes a different value of the corner frequency **142**. Moreover, depending on the physiological waveform that is processed, the variable filter may be a variable high pass, low pass, bandpass, notch and/or other filter, and the filter parameter may be a low pass filter corner frequency, a high pass filter corner frequency, a bandpass filter corner frequency and/or bandwidth and/or a notch frequency. The variable digital filter may be embodied by a plurality of delay taps, the number of which is selected to provide the variable filtering.

[0042] Still continuing with the description of Figure 1, a corner frequency adjuster **140** is provided that is responsive to the heart rate metric extractor **130** and is configured to determine the corner frequency **142** that is applied to the variable high pass filter **120** based on the heart rate metric **132** that was extracted. Accordingly, variable filter adjustment by physiological metric feedback is provided.

[0043] Many embodiments of corner frequency adjusters **140** will be described in detail below. In general, the corner frequency adjuster **140** may be configured to determine a corner frequency that is applied to the variable high pass filter **120** or to select from among a plurality of variable high pass filters, for example by selecting a number of delay taps in a variable digital high pass filter. For example, as will be described in more detail below, the corner frequency adjuster **140** may include a mapping system that is configured to map the heart rate metric **132** that is extracted from the physiological waveform **112** that is filtered by the variable high pass filter **120**, into a number of delay taps that is selected to filter the physiological waveform **112** by the variable high pass filter **120**.

[0044] Figure 2 is a functional block diagram of physiological signal processing systems and methods according to various other embodiments described herein. These physiological signal processing systems and methods **200** are configured to extract cardiovascular and pulmonary physiological signal components that are included in a physiological waveform **112** as provided by the physiological sensor **110**. In some embodiments, the cardiovascular and pulmonary physiological signal components rise and fall in frequency roughly in tandem, and the cardiovascular signal component includes a highest frequency that is higher than the lowest frequency of the pulmonary signal component. It will be understood that more than two physiological signal components may be processed in other embodiments, but only two components are illustrated in Figure 2 for ease of illustration.

[0045] In embodiments of Figure 2, a variable high pass filter **220a** and a variable low pass filter **220b** may be provided. The variable high pass filter **220a** is responsive to the physiological waveform **112** and is configured to high pass filter the physiological waveform in response to a first corner frequency **242a** that is applied thereto. The variable low pass filter **220b** is responsive to the physiological waveform **112** and is configured to low pass filter the physiological waveform in response to a second corner frequency **242b** that is applied thereto. The first and second corner frequencies **242a**, **242b** may be identical in some embodiments, and may be different in other embodiments. Moreover, when the first physiological signal component is a cardiovascular signal component and the second physiological signal component is a pulmonary signal component, the first corner frequency **242a** is a high pass corner frequency and the second corner frequency **242b** is a low pass corner frequency.

[0046] Continuing with the description of Figure 2, a heart rate metric extractor **230a** and a respiration rate metric extractor **230b** may be provided. The heart rate metric **232a** may be processed and analyzed by a heart rate metric assessor **250a**, and the respiration rate **232b** may be processed and analyzed by a respiration rate metric assessor **250b**. Many techniques for operating heart rate and respiration rate metric extractors and assessors are known, and need not be described further herein.

[0047] Still referring to Figure 2, a corner frequency adjuster **240** is provided. The corner frequency adjuster **240** is responsive to the heart rate metric extractor **230a** to determine the first and second corner frequencies **242a** and **242b** that are applied to the variable high pass and low pass filters **220a** and **220b**, respectively. Various embodiments of the corner frequency adjuster **240** may be provided. Various detailed examples will be provided below.

[0048] Figure 3 is a functional block diagram of an embodiment of Figure 1 that may be used to extract a heart rate metric **132** from the physiological waveform **112'** that is produced by a PPG sensor **110'**, wherein the physiological waveform **112'** includes both heart rate (HR) and respiration rate (RR) components. A variable high pass filter **120'** is

embodied in Figure 3 by a plurality of high pass filters **320**, each of which includes a different corner frequency. The heart rate metric extractor **130** is configured to extract a heart rate metric **132** using any known technique. The corner frequency adjuster **140** of Figure 1 is embodied by a corner frequency adjuster **140'**, represented as a switch that is configured to select one of the plurality of high pass filters **320** that corresponds to the corner frequency that is determined.

For example, in some embodiments, the corner frequency adjuster **140'** uses a mapping function to select one of the plurality of high pass filters **320** that has a corner frequency that is within a margin of the heart rate metric **132'**. In some embodiments, the margin may correspond to a margin of between about 18 and about 30 beats per minute below the heart rate metric **132'**. By selecting the appropriate high pass filter **320**, the corner frequency adjuster **140'** can reduce or prevent the respiration rate component from interfering with the extraction of the heart rate component.

[0049] It will be understood that the margin may be selected as a function of the heart rate metric **132**. For example, a table lookup may be used to map a heart rate metric **132** that is extracted into a desired high pass filter corner frequency, and then the filter **320** may be selected that has a corner frequency that is closest to the mapped corner frequency. It will also be understood that hysteresis may be used to reduce or prevent switching of the high pass filters **320** too rapidly, because the rapid switching may adversely affect the extraction of the heart rate metric by the heart rate metric extractor **130**.

[0050] In other embodiments of Figure 3, it may also be desirable to extract a respiration rate metric from the waveform **112'**, so that low pass filters may be used in addition to high pass filters **320**. The corner frequency adjuster **140'** may be configured to adjust low pass filter corner frequency by applying a given margin below the heart rate metric.

[0051] Figure 4 is a more detailed functional block diagram of embodiments of Figure 2, and may be used to extract a heart rate metric **232a** and a respiration rate metric **232b** from a PPG sensor **110'** that provides a PPG sensor waveform **112'** that includes both heart rate and respiration rate components. A variable high pass filter **220a** and a variable low pass filter **220b** is provided. Each of these filters may be embodied by a single filter with an adjustable corner frequency or by multiple filters having different corner frequencies, one of which may be selected. Heart rate extractor **230a** and respiration rate extractor **230b** are responsive to the variable high pass filter **220a** and the variable low pass filter **220b**, respectively, so as to obtain a heart rate metric **232a** and a respiration rate metric **232b**. The corner frequency adjuster previously described may be embodied by a mapping function **340**. As shown in embodiments of Figure 4, the mapping function **340** is responsive to the heart rate metric **232a** and is responsible for determining both the high pass filter corner frequency **242a** and the low pass filter corner frequency **242b**. In some embodiments, the same corner frequency may be used for both the variable high pass filter **220a** and the variable low pass filter **220b**. In other embodiments, the mapping function **340** may determine different corner frequencies **242a** and **242b**.

[0052] In embodiments of Figure 4, only the heart rate metric **232a** is used by the mapping function to determine the corner frequency for both the variable high pass filter **220a** and the variable low pass filter **220b**. It has been found, according to various embodiments described herein, that the heart rate metric **232a** may provide a more accurate basis for determining both corner frequencies, because the heart rate metric may be subject to less conscious control by the user compared to the respiration rate metric. A specific mapping function will be described below.

[0053] As was described above, the variable high pass filter **220a** and/or the variable low pass filter **220b** of Figure 4 may comprise a variable digital high pass filter and/or a variable digital low pass filter. Figure 5 illustrates an embodiment of a variable digital high pass filter, and Figure 6 illustrates an embodiment of a variable digital low pass filter.

[0054] Referring to Figure 5, these embodiments of a variable high pass filter **220a'** include a plurality of high pass delay taps **510** that are generated by a plurality of digital delay elements **520**. The digital delay elements **520** are responsive to an input signal, which may be the physiological waveform **112'** of a PPG sensor, and the variable high pass filter **220a'** provides an output signal, which may be provided to a metric extractor, such as an HR extractor **230a** of Figure 4. A "width" parameter determines the number of delay taps that are selected by a mean block **530** and a summing node **540**, to determine the output signal. As shown in Figure 6, the variable low pass filter **220b'** can include a similar architecture. However, a summer **540** may not be needed in the variable low pass filter **220b'** because the "DELAY" tap already feeds the mean block **530** with the same sign as the other taps **510**.

[0055] Accordingly, Figures 5 and 6 illustrate various embodiments wherein the variable high pass filter (Figure 5) and/or the variable low pass filter (Figure 6) comprises a variable digital high pass filter **220a'** and/or a variable digital low pass filter **220b'** having a plurality of high pass and/or low pass delays taps **510**, respectively, wherein the corner frequency is determined by a number of high pass and/or low pass delay taps **510** that are selected to filter the physiological waveform.

[0056] A specific embodiment of a mapping function **340** will now be described. In these embodiments, the mapping function **340** is configured to determine a corner frequency **242a** of the variable high pass filter **220a'** and the corner frequency **242b** of the variable low pass filter **220b'** by applying a margin to the heart rate metric **232a**, and is further configured to determine the number of delay taps **510** from the corner frequency that was determined.

[0057] A mathematical description of this mapping function **340** may be provided by Equations (1) and (2):

$$\text{CornerFreq} = \max(\text{MINIMUM_HR_BPM}, \text{HeartRate} - \text{MARGIN_BPM}) \quad (1)$$

$$\text{Width} = \text{round}(\text{DELAY} * \text{MINIMUM_HR_BPM} / \text{CornerFreq}) \quad (2)$$

[0058] In Equations (1) and (2), variables in CAPITAL LETTERS are predetermined constants, while variables in CamelCase may change every frame. In this mapping function, CornerFreq is the corner frequency **242a** and **242b**. MINIMUM_HR_BPM is the minimum heart rate to be measured in beats per minute. HeartRate is the heart rate metric **232a** that is measured. MARGIN_BPM is a desired margin between the reported heart rate and the corner frequency of the variable filter, which may be empirically determined. The margin allows for some error in the reported heart rate without causing significant attenuation by the variable high pass filter. Accordingly, in Equation (1) the corner frequency is determined by the maximum of either the minimum heart rate or the measured heart rate minus the margin that is set. Moreover, in Equation (2), Width is the parameter in Figures 5 and 6 that determines the number of delay taps **510**. Specifically, in Figures 5 and 6, two times the width determines the number of delay taps that are input into the mean block **530**. As shown in Equation (2), the width may be determined by rounding up or down the value of the delay of each of the delay elements **520** multiplied by the minimum heart rate divided by the corner frequency that was determined in Equation (1).

[0059] Accordingly, Equations (1) and (2) illustrate an embodiment wherein the mapping function **340** is configured to determine a corner frequency of the variable low pass filter **220b** and the variable high pass filter **220a** by determining a maximum of a minimum heart rate, and the heart rate metric **232a** minus the margin, and is further configured to determine the number of delay taps **510** by rounding a product of the delay **520** of the delay taps **510** and the minimum heart rate divided by the corner frequency **242a/242b** that was determined. It will be understood, however, that many other mapping functions may be provided according to other embodiments described herein.

[0060] Embodiments that were described above in connection with Figures 1-4 use a heart rate metric that was extracted to provide corner frequency adjustment of a variable high pass filter for a heart rate metric extractor, and may also use the heart rate metric that was extracted to adjust a corner frequency of a variable low pass filter of a respiration rate metric extractor. Heretofore, it does not appear that feedback of an extracted heart rate was used to control a high pass filter feeding a heart rate metric extractor. Specifically, because of the possibility for the extracted heart rate to be in error, the variable high pass filter may blind the heart rate metric extractor from the heart rate frequency in the physiological waveform. Stated differently, the heart rate metric extractor could lock on, i.e., get stuck at, a high rate, and remain unresponsive to the actual heart rate in the physiological waveform. Specifically, if the heart rate metric extractor locks on a high rate, the variable high pass filter may filter out the actual (lower) heart rate frequency in the physiological waveform. Accordingly, the heart rate metric extractor may diverge or run away from the actual heart rate. Thus, heretofore, feedback of the extracted heart rate to control the high pass filter feeding the heart rate metric extractor does not appear to have been used. In sharp contrast, various embodiments described herein can reduce or prevent locking on an erroneous heart rate metric. Thus, various embodiments described herein can use feedback of the heart rate metric that was extracted to control the high pass filter feeding the heart rate metric extractor, as was illustrated in Figures 1-4. The heart rate metric that was extracted may also be used to feed the low pass filter for the respiration rate metric extractor, as was shown in Figures 2 and 4.

[0061] Figure 7 is a flowchart of operations that may be performed by a corner frequency adjuster **700**, such as the corner frequency adjuster **140** of Figure 1, the corner frequency adjuster **240** of Figure 2, the corner frequency adjuster **140'** of Figure 3, or the mapping function **340** of Figure 4, to reduce or prevent an erroneous extracted heart rate from blinding the heart rate metric extractor to the heart rate frequency in the physiological waveform. Referring now to Figure 7, the corner frequency adjuster **700** may be configured to initially set at least one predetermined corner frequency corresponding to a predetermined heart rate prior to determining the at least one corner frequency that is applied to the variable high pass filter, and in some embodiments to the variable low pass filter, from the heart rate metric, as illustrated at Block **710**. Thus, at startup, the extracted heart rate **132** may be initialized to a predetermined, relatively low heart rate, such as a resting heart rate of, for example, 72 beats per minute. By initially setting the extracted heart **132** at a low value, subsequent blinding of the metric extractor by the high pass filter that is set for a high heart rate, may be reduced or prevented. Thus, the corner frequency adjuster **700** is configured to reduce or prevent locking on an erroneous heart rate in the physiological waveform.

[0062] Then, at Block **720**, once a heart rate metric is locked, the heart rate metric that was extracted may be used to determine the corner frequency at Block **730**. Thus, Blocks **710-730** illustrate the use of a "hunting mode" at startup, where the corner frequency of the high pass filter, and in some embodiments of the low pass filter, is set at a predetermined frequency (Block **710**) until the heart rate metric extractor locks on the heart rate PPG signal at Block **720**. Then, the heart rate metric that was extracted may be used at Block **730**.

[0063] One way to determine that the heart rate metric extractor has locked on the heart rate in the physiological waveform at Block **720** is to determine when the physiological waveform spectral peak is within a window around the extracted heart rate. The window may be a predetermined window that remains constant, or may be a variable window. If the spectral peak is within the window around the extracted heart rate, the heart rate may be deemed to be believed,

whereas if it is outside the window, it could be noise, and therefore be erroneous.

[0064] Finally, at Block **740**, a determination may be made that the physiological waveform signal is lost, for example, because the physiological sensor **110** goes off the body. A determination that the physiological sensor goes off the body may be obtained using a proximity sensor and/or other techniques. If the signal is lost at Block **740**, operations may return to Block **710** to reset (i.e., reapply) the predetermined heart rate and then return into hunting mode at Blocks **720** and **730**. On the other hand, as long as the signal is not lost at Block **740**, the heart rate metric that was extracted may continue to be used to determine the at least one corner frequency at Block **730**. Thus, the corner frequency adjuster is configured to reduce or prevent locking on an erroneous heart rate metric.

[0065] Other techniques may also be used to reduce or prevent the high pass filter from blinding the metric extractor to the heart rate frequency in the physiological waveform. For example, the high pass filters **120**, **220a**, **120'** or **220a'** may all use a gradual filter transition band. Stated differently, brick wall high pass filters are not used in these embodiments. Thus, the gradual transition high pass filter may have a greater ability to include the heart rate frequency in the high pass filtered signal. Another technique may use a margin between the extracted heart rate and the corner frequency of the high pass filter. For example, 18 beats per minute margin may be used, as was already described. The above described techniques may be used individually, or in various combinations and subcombinations, to reduce or prevent the high pass filter from blinding the metric extractor from the heart rate frequency in the physiological waveform, and thereby reduce or prevent locking on an erroneous heart rate metric.

[0066] Figure 8 illustrates how the corner frequency of a variable high pass filter, such as the variable high pass filter **220a'** of Figure 5, may be varied using the mapping function **340** described by Equations (1) and (2) above, according to various embodiments described herein. Figure 8 assumes a value of DELAY of 15 samples and plots the frequency response of the variable high pass filter **220a'** with various width values from 10 to 15 at a sample rate of 25Hz. As shown, the corner frequency of the variable high pass filter **220a'**, which may be measured at, for example, the -2 dB, -3dB or -6dB magnitude, can be varied by varying the width parameter. The high pass filter of Figure 8 may be used to extract the heart rate metric **232a**.

[0067] Figure 9 illustrates analogous operations for a variable digital low pass filter **220b'**, such as illustrated in Figure 6. Again, in Figure 9, a DELAY value of 15 samples is plotted as a function of widths from 10 to 15. The cutoff frequency may be measured, for example, by the -12dB, -10dB or -8dB points in the magnitude. Accordingly, variable cutoff frequency low pass filters may be used to extract the respiration rate metric **232b**.

[0068] Figures 10-15 illustrate other measured results. Specifically, Figure 10 graphically illustrates a typical noise-reduced PPG spectrum.

[0069] Figure 11 illustrates a signal-to-noise-and-distortion measurement for the same signal in Figure 10.

[0070] Figure 12 illustrates raw samples of the physiological waveform **112'** that may be obtained by a PPG sensor **110'**.

[0071] Figure 13 illustrates heart rate **HR** (**232a** of Figure 4) and step rate **SR** (in steps per minute) that may be extracted by a system and/or method of Figure 4 over time.

[0072] Figure 14 illustrates a respiration rate metric that may be provided by a respiration rate extractor **230b** of Figure 4 as a function of time. Finally, Figure 15 illustrates a peak normalized spectrum for the respiration rate.

[0073] Various embodiments have been described herein primarily with respect to physiological signal processing systems. However, Figures 1-7 also describe analogous physical signal processing methods according to various embodiments described herein. For example, various analogous method embodiments described herein can select among multiple filters for extracting a physiological signal component, where the selection is controlled by an extracted physiological metric. The physiological metric can be the same or different than the physiological component. For example, an extracted heart rate metric can control the filtering of both heart rate and respiration rate. Variable filter adjustment by physiological waveform metric feedback may thereby be provided.

[0074] Various embodiments have been described herein with reference to block diagrams and a flowchart of methods, apparatus (systems and/or devices) and/or computer program products. It is understood that a block of the block diagrams and/or flowchart, and combinations of blocks in the block diagrams and/or flowchart, can be implemented by computer program instructions that are performed by one or more computer circuits. These computer program instructions may be provided to a processor circuit of a general purpose computer circuit, special purpose computer circuit, and/or other programmable data processing circuit to produce a machine, such that the instructions, which execute via the processor of the computer and/or other programmable data processing apparatus, transform and control transistors, values stored in memory locations, and other hardware components within such circuitry to implement the functions/acts specified in the block diagrams and/or flowchart, and thereby create means (functionality), structure and/or methods for implementing the functions/acts specified in the block diagrams and/or flowchart.

[0075] These computer program instructions may also be stored in a computer-readable medium that can direct a

computer or other programmable data processing apparatus to function in a particular manner, such that the instructions stored in the computer-readable medium produce an article of manufacture including instructions which implement the functions/acts specified in the block diagrams and/or flowchart block or blocks.

5 **[0076]** A tangible, non-transitory computer-readable medium may include an electronic, magnetic, optical, electro-magnetic, or semiconductor data storage system, apparatus, or device. More specific examples of the computer-readable medium would include the following: a portable computer diskette, a random access memory (RAM) circuit, a read-only memory (ROM) circuit, an erasable programmable read-only memory (EPROM or Flash memory) circuit, a portable compact disc read-only memory (CD-ROM), and a portable digital video disc read-only memory (DVD/Blu-ray™).

10 **[0077]** The computer program instructions may also be loaded onto a computer and/or other programmable data processing apparatus to cause a series of operational steps to be performed on the computer and/or other programmable apparatus to produce a computer-implemented process or method such that the instructions which execute on the computer or other programmable apparatus provide steps for implementing the functions/acts specified in the block diagrams and/or flowchart.

15 **[0078]** Accordingly, the invention may be embodied in hardware and/or in software (including firmware, resident software, micro-code, etc.) that runs on a processor such as a digital signal processor, which may collectively be referred to as "circuitry," "a module" or variants thereof.

20 **[0079]** It should also be noted that in some alternate implementations, the functions/acts noted in the blocks may occur out of the order noted in the blocks. For example, two blocks shown in succession may in fact be executed substantially concurrently or the blocks may sometimes be executed in the reverse order, depending upon the functionality/acts involved. Moreover, the functionality of a given block of the block diagrams and/or flowchart may be separated into multiple blocks and/or the functionality of two or more blocks of the block diagrams and/or flowchart may be at least partially integrated. Finally, other blocks may be added/inserted between the blocks that are illustrated.

25 **[0080]** Aspects and embodiments of the invention will be further understood with reference to the following non-limiting clauses:

1. A physiological signal processing system comprising:

a physiological sensor that is configured to generate a physiological waveform that includes cardiovascular and pulmonary signal components therein;

30 a variable high pass filter and a variable low pass filter that are responsive to the physiological waveform and that are configured to high pass and low pass filter, respectively, the physiological waveform in response to at least one corner frequency that is applied thereto;

a heart rate metric extractor that is responsive to the variable high pass filter and that is configured to extract a heart rate metric from the physiological waveform that is filtered by the variable high pass filter;

35 a respiration rate metric extractor that is responsive to the variable low pass filter and that is configured to extract a respiration rate metric from the physiological waveform that is filtered by the variable low pass filter; and

a corner frequency adjustor that is responsive to the metric extractor and that is configured to determine the at least one corner frequency that is applied to the variable high pass filter and the variable low pass filter from the heart rate metric.

40 2. A physiological signal processing system according to Clause 1 wherein the variable high pass filter comprises a single high pass filter and the variable low pass filter comprises a single low pass filter, each having an adjustable corner frequency, and wherein the corner frequency adjustor is configured to determine the adjustable corner frequency for the single high pass filter and the single low pass filter.

45 3. A physiological signal processing system according to Clause 1 wherein the variable high pass filter comprises a plurality of high pass filters and the variable low pass filter comprises a plurality of low pass filters, a respective one of which includes a different corner frequency, and wherein the corner frequency adjustor is configured to select one of the plurality of high pass filters and one of the plurality of low pass filters that corresponds to the at least one corner frequency that is determined by the corner frequency adjustor.

50 4. A physiological signal processing system according to Clause 1:

55 wherein the variable high pass filter is responsive to the physiological waveform and is configured to filter the physiological waveform in response to a high pass filter corner frequency that is applied thereto;

wherein the variable low pass filter is responsive to the physiological waveform and is configured to filter the physiological waveform in response to a low pass filter corner frequency that is applied thereto; and

wherein the corner frequency adjustor is configured to determine the high pass filter corner frequency and the

low pass filter corner frequency that is applied to the variable high pass filter and the variable low pass filter, respectively, in response to the heart rate metric extracted by the heart rate metric extractor.

5 5. A physiological signal processing system according to Clause 2 wherein the variable high pass filter comprises a variable digital high pass filter having a plurality of high pass delay taps and the variable low pass filter comprises a variable digital low pass filter having a plurality of low pass delay taps, and wherein the adjustable corner frequency is determined by a number of the high pass and low pass delay taps that are selected to filter the physiological waveform.

10 6. A physiological signal processing system according to Clause 5 wherein the corner frequency adjustor comprises a mapping system that is configured to map the heart rate metric that is extracted from the physiological waveform that is filtered into the number of the delay taps that are selected to filter the physiological waveform.

15 7. A physiological signal processing system according to Clause 6 wherein the mapping system is configured to determine a corner frequency of the variable digital low pass filter and the variable digital high pass filter by determining a maximum of a minimum heart rate and the heart rate metric minus a margin, and is further configured to determine the number of delay taps by rounding a product of the delay of the delay taps and the minimum heart rate divided by the corner frequency that was determined.

20 8. A physiological signal processing system according to Clause 6 wherein the mapping system is configured to determine a corner frequency of the variable low pass filter and the variable high pass filter by applying a margin to the heart rate metric, and is further configured to determine the number of delay taps from the corner frequency that was determined.

25 9. A physiological signal processing system according to Clause 1 wherein the corner frequency adjuster includes hysteresis.

30 10. A physiological signal processing system according to Clause 1 wherein the at least one corner frequency comprises a same corner frequency that is applied to the variable high pass and low pass filters.

11. A physiological signal processing system according to Clause 1 wherein the sensor is a plethysmograph sensor.

35 12. A physiological signal processing system according to Clause 11 wherein the plethysmograph sensor is a photoplethysmograph sensor.

13. A physiological signal processing system according to Clause 1 wherein the corner frequency adjuster is configured to reduce locking on an erroneous heart rate metric.

40 14. A physiological signal processing system according to Clause 1 wherein the corner frequency adjuster is configured to initially set at least one predetermined corner frequency corresponding to a predetermined heart rate prior to determining the at least one corner frequency that is applied to the variable high pass filter and the variable low pass filter from the heart rate metric.

45 15. A physiological signal processing system according to Clause 14 wherein the predetermined heart rate is a resting heart rate.

50 16. A physiological signal processing system according to Clause 14 wherein the corner frequency adjuster is configured to initially set the at least one predetermined corner frequency corresponding to the predetermined heart rate until the heart rate metric extractor locks on a heart rate in the physiological waveform.

17. A physiological signal processing system according to Clause 14 wherein the corner frequency adjuster is configured to reset the predetermined corner frequency corresponding to the predetermined heart rate in response to determining that the physiological sensor is no longer responsive to a source of the physiological waveform.

55 18. A physiological signal processing system according to Clause 1 wherein the corner frequency adjuster is configured to set at least one predetermined corner frequency corresponding to a predetermined heart rate in response to determining that the physiological sensor is not responsive to a source of the physiological waveform.

19. A physiological signal processing system according to Clause 1 wherein the corner frequency adjuster is configured to determine the at least one corner frequency that is applied to the variable high pass filter and the variable low pass filter from the heart rate metric by applying a margin to the heart rate metric.

5 20. A physiological signal processing system according to Clause 1 wherein the variable high pass filter includes a gradual filter transition band.

10 21. A physiological signal processing system for a physiological waveform that includes a cardiovascular signal component therein, the physiological signal processing system comprising:

- a variable high pass filter that is responsive to the physiological waveform and that is configured to high pass filter the physiological waveform in response to a corner frequency that is applied thereto;
- a heart rate metric extractor that is responsive to the variable high pass filter and that is configured to extract a heart rate metric from the physiological waveform that is high pass filtered; and
- 15 a corner frequency adjuster that is responsive to the heart rate metric extractor and that is configured to determine the corner frequency that is applied to the variable high pass filter, based on the heart rate metric that was extracted.

20 22. A physiological signal processing system according to Clause 21 wherein the physiological waveform comprises an electrical physiological waveform including an electroencephalogram (EEG), an electrocardiogram (ECG) and/or a radio frequency (RF) waveform, an electro-optical physiological waveform including a photoplethysmograph (PPG) waveform, an electro-photoacoustic waveform including a photoacoustic waveform, an electro-mechanical physiological waveform including an auscultation waveform, a piezo sensor waveform and/or an accelerometer waveform, and/or an electro-nuclear physiological waveform.

25 23. A physiological signal processing system according to Clause 21 wherein the variable high pass filter comprises a single high pass filter having an adjustable corner frequency.

30 24. A physiological signal processing system according to Clause 21 wherein the variable high pass filter comprises a plurality of high pass filters, a respective one of which includes a different value of the corner frequency, and wherein the corner frequency adjuster is configured to select one of the plurality of high pass filters that corresponds to the corner frequency that is determined.

35 25. A physiological signal processing system according to Clause 21 wherein the variable high pass filter comprises a variable digital high pass filter having a plurality of delay taps and wherein the corner frequency corresponds to a number of the plurality of delay taps that are selected to filter the physiological waveform.

40 26. A physiological signal processing system according to Clause 25 wherein the corner frequency adjuster comprises a mapping system that is configured to map the heart rate metric that is extracted from the physiological waveform that is filtered into the number of the delay taps that are selected to high pass filter the physiological waveform.

27. A physiological signal processing system according to Clause 21 further comprising a PPG sensor that is configured to generate the PPG waveform that includes the cardiovascular signal component therein.

45 28. A physiological signal processing system according to Clause 21 wherein the corner frequency adjuster is configured to reduce locking on an erroneous heart rate metric.

50 29. A physiological signal processing system according to Clause 21 wherein the corner frequency adjuster is configured to initially set a predetermined corner frequency corresponding to a predetermined heart rate prior to determining the corner frequency that is applied to the variable high pass filter from the heart rate metric.

30. A physiological signal processing system according to Clause 29 wherein the predetermined heart rate is a resting heart rate.

55 31. A physiological signal processing system according to Clause 29 wherein the corner frequency adjuster is configured to initially set the predetermined corner frequency corresponding to the predetermined heart rate until the heart rate metric extractor locks on a heart rate in the physiological waveform.

32. A physiological signal processing system according to Clause 29 wherein the corner frequency adjuster is configured to reset the predetermined corner frequency corresponding to the predetermined heart rate in response to determining that the physiological sensor is no longer responsive to a source of the physiological waveform.

5 33. A physiological signal processing system according to Clause 21 wherein the corner frequency adjuster is configured to set a predetermined corner frequency corresponding to a predetermined heart rate in response to determining that the physiological sensor is not responsive to a source of the physiological waveform.

10 34. A physiological signal processing system according to Clause 21 wherein the corner frequency adjuster is configured to determine the corner frequency that is applied to the variable high pass filter from the heart rate metric by applying a margin to the heart rate metric.

15 35. A physiological signal processing system according to Clause 21 wherein the variable high pass filter includes a gradual filter transition band.

36. A physiological signal processing system according to Clause 21 further comprising:

a physiological metric assessor that is responsive to the heart rate metric extractor and that is configured to process the heart rate metric to generate at least one physiological assessment.

20 37. A physiological signal processing system according to Clause 36 wherein the at least one physiological assessment includes ventilator threshold, lactate threshold, cardiopulmonary status, neurological status, aerobic capacity (VO2 max) and/or overall health or fitness.

25 38. A physiological signal processing method comprising:

obtaining a physiological waveform that includes cardiovascular and pulmonary signal components therein;
variable high pass and low pass filtering the physiological waveform in response to at least one corner frequency;
extracting a heart rate metric from the physiological waveform that is filtered by the variable high pass filtering;
30 extracting a respiration rate metric from the physiological waveform that is filtered by the variable low pass filtering; and
determining the at least one corner frequency that is applied to the variable high pass and low pass filtering, from the heart rate metric that was extracted.

35 39. A physiological signal processing method according to Clause 38 wherein the determining comprises adjusting the corner frequency of the variable high pass and low pass filtering.

40 40. A physiological signal processing method according to Clause 38 wherein the determining comprises selecting one of a plurality of high pass and low pass filters that corresponds to the at least one corner frequency that is determined.

45 41. A physiological signal processing method according to Clause 38 wherein the determining comprises determining a number of a plurality of high pass and low pass delay taps that are selected by the variable high pass and low pass filtering.

42. A physiological signal processing method according to Clause 41 wherein the determining comprises mapping the heart rate metric into the number of the delay taps.

50 43. A physiological signal processing method according to Clause 42 wherein the mapping comprises:

determining a corner frequency of the variable low pass and the variable high pass filtering by applying a margin to the heart rate metric; and
determining the number of delay taps from the corner frequency.

55 44. A physiological signal processing method according to Clause 38 wherein the determining comprises reducing locking on an erroneous heart rate metric.

45. A physiological signal processing method according to Clause 38 further comprising:

initially setting a predetermined corner frequency corresponding to a predetermined heart rate prior to the determining the at least one corner frequency that is applied to the variable high pass and low pass filtering from the heart rate metric.

5 46. A physiological signal processing method according to Clause 45 wherein the predetermined heart rate is a resting heart rate.

10 47. A physiological signal processing method according to Clause 45 wherein the initially setting comprises initially setting the predetermined corner frequency corresponding to the predetermined heart rate until the extracting locks on a heart rate in the physiological waveform.

15 48. A physiological signal processing method according to Clause 45 further comprising:
resetting the predetermined corner frequency corresponding to the predetermined heart rate in response to determining that the physiological waveform is no longer being obtained.

20 49. A physiological signal processing method according to Clause 38 further comprising:
setting a predetermined corner frequency corresponding to a predetermined heart rate in response to determining that the physiological waveform is no longer being obtained.

25 50. A physiological signal processing method according to Clause 38 wherein the determining the at least one corner frequency that is applied to the variable high pass and low pass filtering from the heart rate metric comprises applying a margin to the heart rate metric.

51. A physiological signal processing method according to Clause 38 wherein the variable high pass filtering comprises a gradual filter transition band.

30 52. A physiological signal processing method for a physiological waveform that includes a cardiovascular signal component therein, the physiological signal processing method comprising:
high pass filtering the physiological waveform in response to an adjustable high pass filter corner frequency;
extracting a heart rate metric from the physiological waveform that is high pass filtered; and
35 determining the adjustable high pass filter corner frequency that is applied to the high pass filtering, from the heart rate metric that was extracted.

53. A physiological signal processing method according to Clause 52 wherein the determining comprises adjusting a high pass filter corner frequency of a single high pass filter.

40 54. A physiological signal processing method according to Clause 52 wherein the determining comprises selecting one of a plurality of high pass filters that corresponds to the corner frequency that is determined.

45 55. A physiological signal processing method according to Clause 52 wherein the determining comprises determining a number of a plurality of delay taps that are selected in the filtering.

56. A physiological signal processing method according to Clause 52 wherein the determining comprises reducing locking on an erroneous heart rate metric.

50 57. A physiological signal processing method according to Clause 52 further comprising:
initially setting a predetermined corner frequency corresponding to a predetermined heart rate prior to the determining the at least one corner frequency that is applied to the variable high pass filtering from the heart rate metric.

55 58. A physiological signal processing method according to Clause 57 wherein the predetermined heart rate is a resting heart rate.

59. A physiological signal processing method according to Clause 57 wherein the initially setting comprises initially

setting the predetermined corner frequency corresponding to the predetermined heart rate until the extracting locks on a heart rate in the physiological waveform.

5 60. A physiological signal processing method according to Clause 57 further comprising:

resetting the predetermined corner frequency corresponding to the predetermined heart rate in response to determining that the physiological waveform is no longer being obtained.

10 61. A physiological signal processing method according to Clause 52 further comprising:

setting a predetermined corner frequency corresponding to a predetermined heart rate in response to determining that the physiological waveform is no longer being determined.

15 62. A physiological signal processing method according to Clause 52 wherein the determining the corner frequency that is applied to the variable high pass filtering from the heart rate metric comprises applying a margin to the heart rate metric.

20 63. A physiological signal processing method according to Clause 52 wherein the variable high pass filtering comprises a gradual filter transition band.

25 **[0081]** Many different embodiments have been disclosed herein, in connection with the above description and the drawings. It will be understood that it would be unduly repetitious and obfuscating to literally describe and illustrate every combination and subcombination of these embodiments. Accordingly, the present specification, including the drawings, shall be construed to constitute a complete written description of all combinations and subcombinations of the embodi-

30 **[0082]** In the drawings and specification, there have been disclosed embodiments of the invention and, although specific terms are employed, they are used in a generic and descriptive sense only and not for purposes of limitation, the scope of the invention being set forth in the following claims.

Claims

35 1. A physiological signal processing system comprising:

a physiological sensor that is configured to generate a physiological waveform that includes a cardiovascular signal component therein;
 a variable high pass filter that is responsive to the physiological waveform and that is configured to high pass filter the physiological waveform in response to a corner frequency that is applied thereto;
 40 a heart rate metric extractor that is responsive to the variable high pass filter and that is configured to extract a heart rate metric from the physiological waveform that is high pass filtered; and
 a corner frequency adjustor that is responsive to the heart rate metric extractor and that is configured to determine the corner frequency that is applied to the variable high pass filter, based on the heart rate metric that was extracted from the physiological waveform.

45 2. A physiological signal processing system according to Claim 1 wherein the physiological waveform comprises an electrical physiological waveform including an electroencephalogram (EEG), an electrocardiogram (ECG) and/or a radio frequency (RF) waveform, an electro-optical physiological waveform including a photoplethysmograph (PPG) waveform, an electro-photoacoustic waveform including a photoacoustic waveform, an electro-mechanical physio-
 50 logical waveform including an auscultation waveform, a piezo sensor waveform and/or an accelerometer waveform, and/or an electro-nuclear physiological waveform.

55 3. A physiological signal processing system according to Claim 1 or 2 wherein the variable high pass filter comprises a plurality of high pass filters, a respective one of which includes a different value of the corner frequency, and wherein the corner frequency adjustor is configured to select one of the plurality of high pass filters that corresponds to the corner frequency that is determined.

4. A physiological signal processing system according to any preceding claim wherein the variable high pass filter

comprises a variable digital high pass filter having a plurality of delay taps and wherein the corner frequency corresponds to a number of the plurality of delay taps that are selected to filter the physiological waveform.

- 5 5. A physiological signal processing system according to Claim 4 wherein the corner frequency adjustor comprises a mapping system that is configured to map the heart rate metric that is extracted from the physiological waveform that is filtered into the number of the delay taps that are selected to high pass filter the physiological waveform, and optionally wherein the mapping system is configured to determine the corner frequency of the digital high pass filter by determining a maximum of a minimum heart rate and the heart rate metric minus a margin, and is further configured to determine the number of delay taps by rounding a product of a delay of the delay taps and the minimum heart rate divided by the corner frequency that was determined.
- 10 6. A physiological signal processing system according to any preceding claim wherein the corner frequency adjuster is configured to reduce locking on an erroneous heart rate metric.
- 15 7. A physiological signal processing system according to any preceding claim wherein the corner frequency adjuster is configured to initially set a predetermined corner frequency corresponding to a predetermined heart rate prior to determining the corner frequency that is applied to the variable high pass filter from the heart rate metric.
- 20 8. A physiological signal processing system according to Claim 7 wherein the corner frequency adjuster is configured to initially set the predetermined corner frequency corresponding to the predetermined heart rate until the heart rate metric extractor locks on a heart rate in the physiological waveform.
- 25 9. A physiological signal processing system according to Claim 7 wherein the corner frequency adjuster is configured to reset the predetermined corner frequency corresponding to the predetermined heart rate in response to determining that the physiological sensor is no longer responsive to a source of the physiological waveform.
- 30 10. A physiological signal processing system according to any preceding claim wherein the corner frequency adjuster is configured to set a predetermined corner frequency corresponding to a predetermined heart rate in response to determining that the physiological sensor is not responsive to a source of the physiological waveform.
- 35 11. A physiological signal processing system according to any preceding claim wherein the corner frequency adjuster is configured to determine the corner frequency that is applied to the variable high pass filter from the heart rate metric by applying a margin to the heart rate metric.
- 40 12. A physiological signal processing method for a physiological waveform that includes a cardiovascular signal component therein, the physiological signal processing method comprising:
 - high pass filtering the physiological waveform in response to an adjustable high pass filter corner frequency;
 - extracting a heart rate metric from the physiological waveform that is high pass filtered; and
 - determining the adjustable high pass filter corner frequency that is applied to the high pass filtering, from the heart rate metric that was extracted from the physiological waveform.
- 45 13. A physiological signal processing method according to Claim 12 wherein the determining comprises selecting one of a plurality of high pass filters that corresponds to the corner frequency that is determined.
- 50 14. A physiological signal processing method according to any of Claims 12-13 wherein the determining comprises determining a number of a plurality of delay taps that are selected in the high pass filtering.
- 55 15. A physiological signal processing method according to any of Claims 12-14, wherein the determining comprises reducing locking on an erroneous heart rate metric.
16. A physiological signal processing method according to any of Claims 12-15, further comprising:
 - initially setting a predetermined corner frequency corresponding to a predetermined heart rate prior to the determining the at least one corner frequency that is applied to the variable high pass filtering from the heart rate metric, and optionally:

wherein the initially setting comprises initially setting the predetermined corner frequency corresponding to

EP 3 222 210 A1

the predetermined heart rate until the extracting locks on a heart rate in the physiological waveform; or setting or resetting the predetermined corner frequency corresponding to the predetermined heart rate in response to determining that the physiological waveform is no longer being obtained.

- 5 **17.** A physiological signal processing method according to any of Claims 12-16, wherein the determining the corner frequency that is applied to the variable high pass filtering from the heart rate metric comprises applying a margin to the heart rate metric.

10

15

20

25

30

35

40

45

50

55

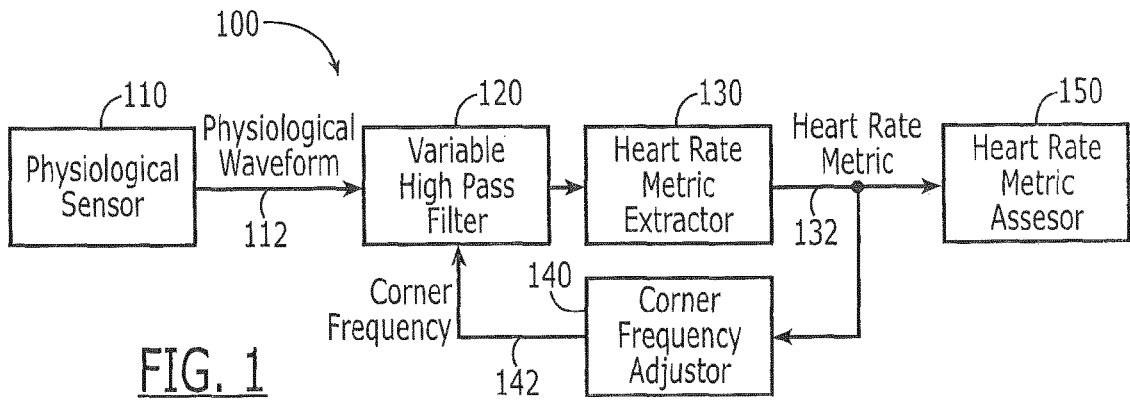

FIG. 1

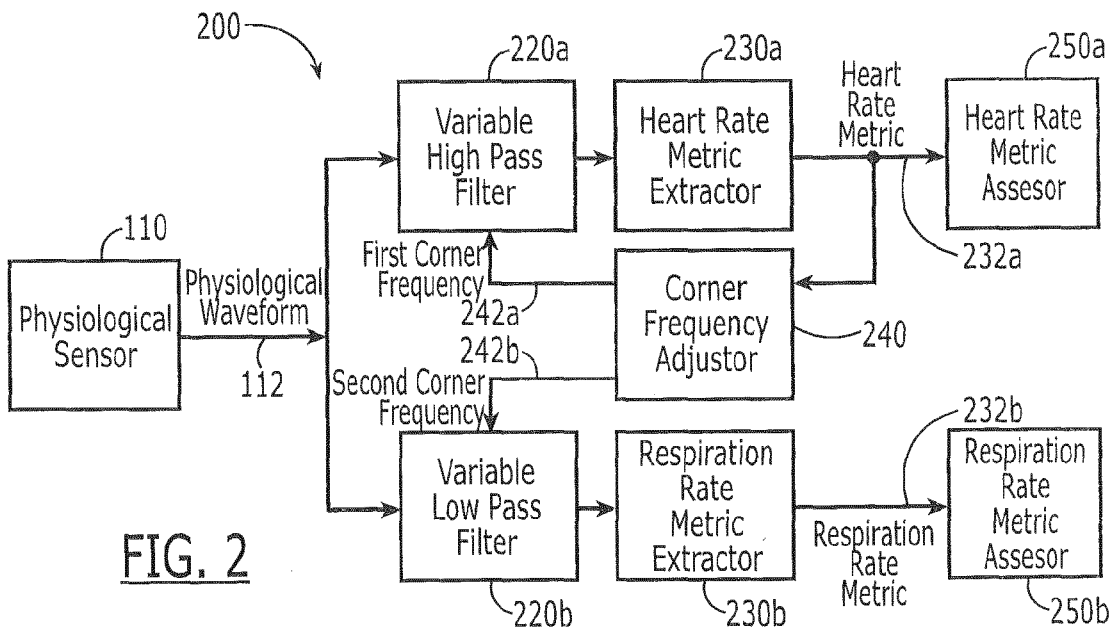

FIG. 2

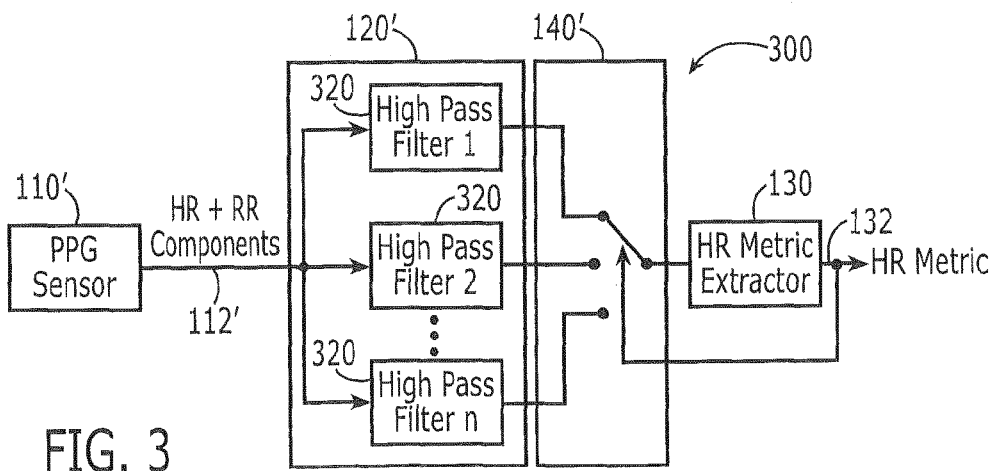

FIG. 3

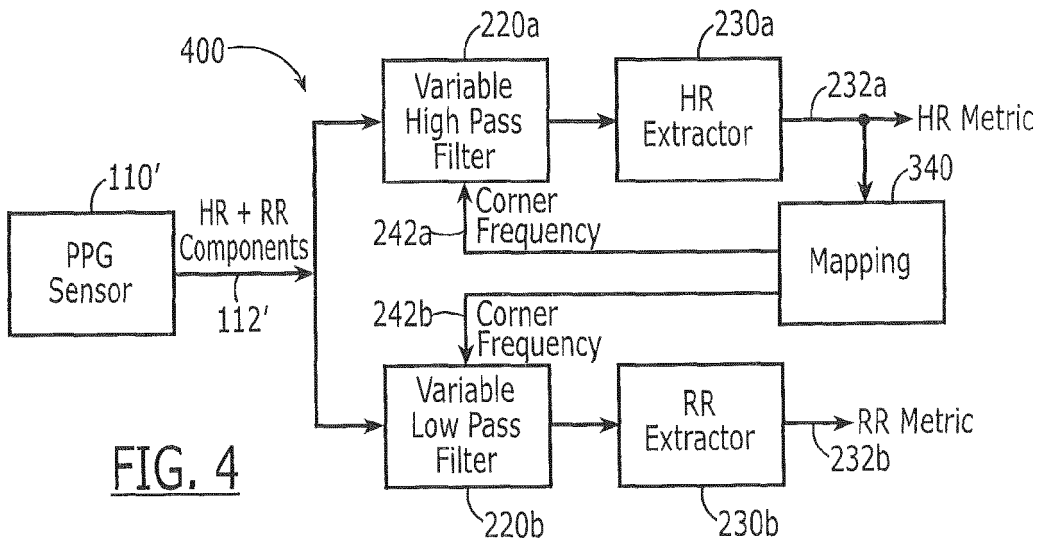

FIG. 4

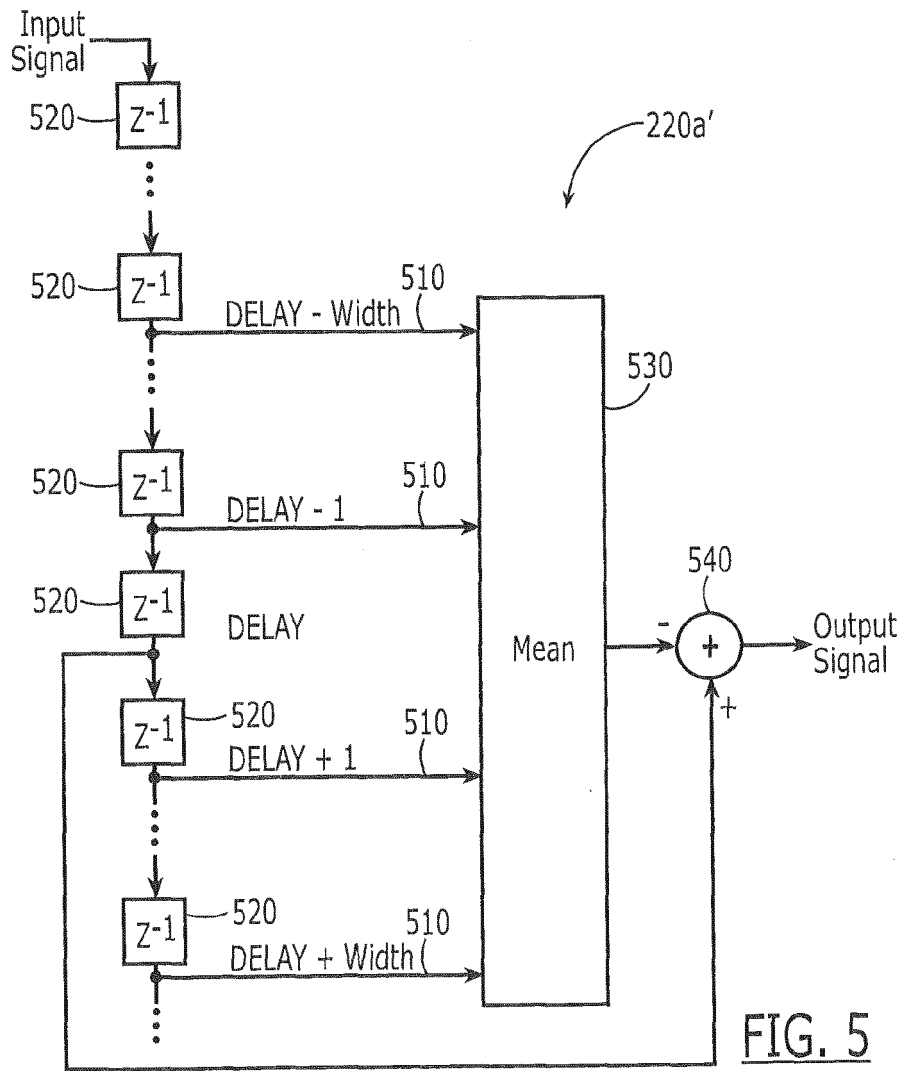
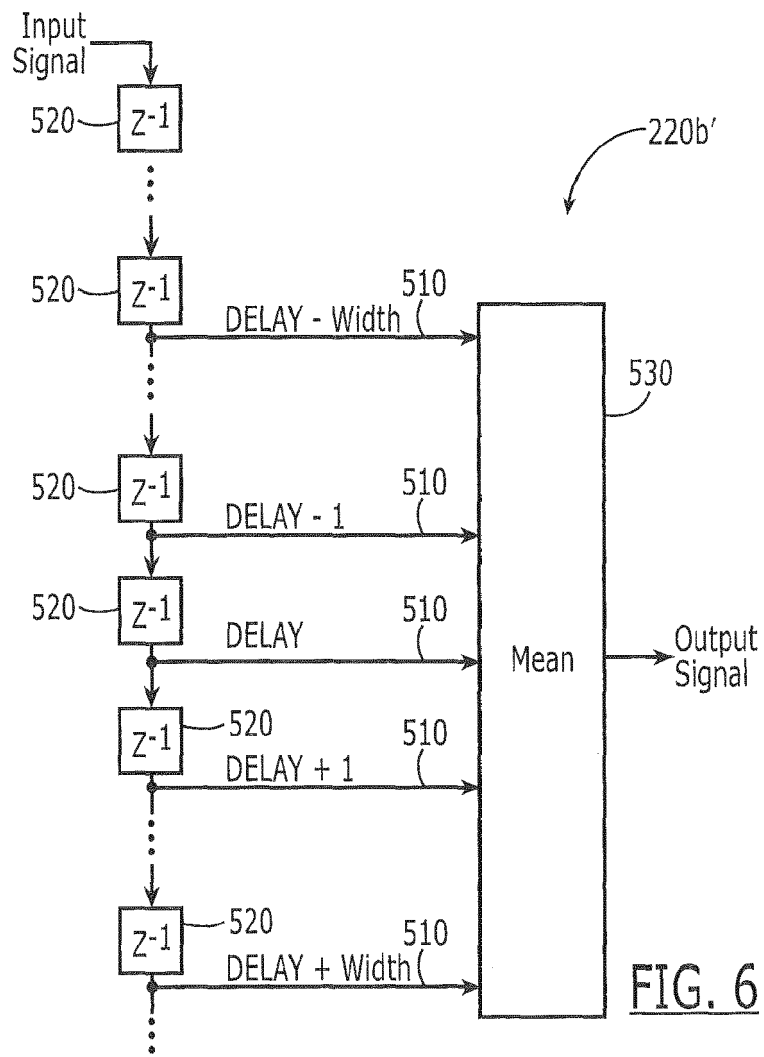

FIG. 5



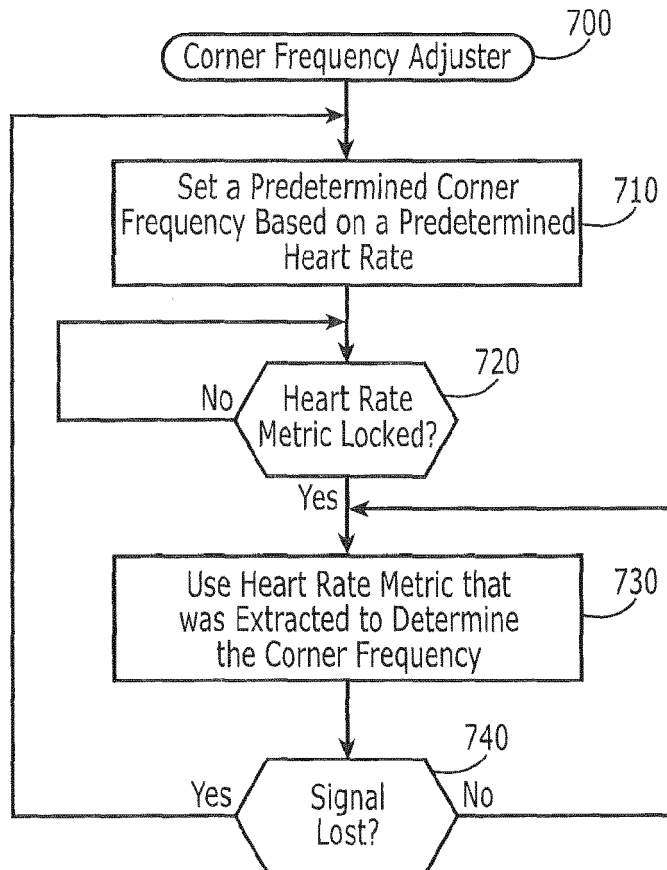

FIG. 7

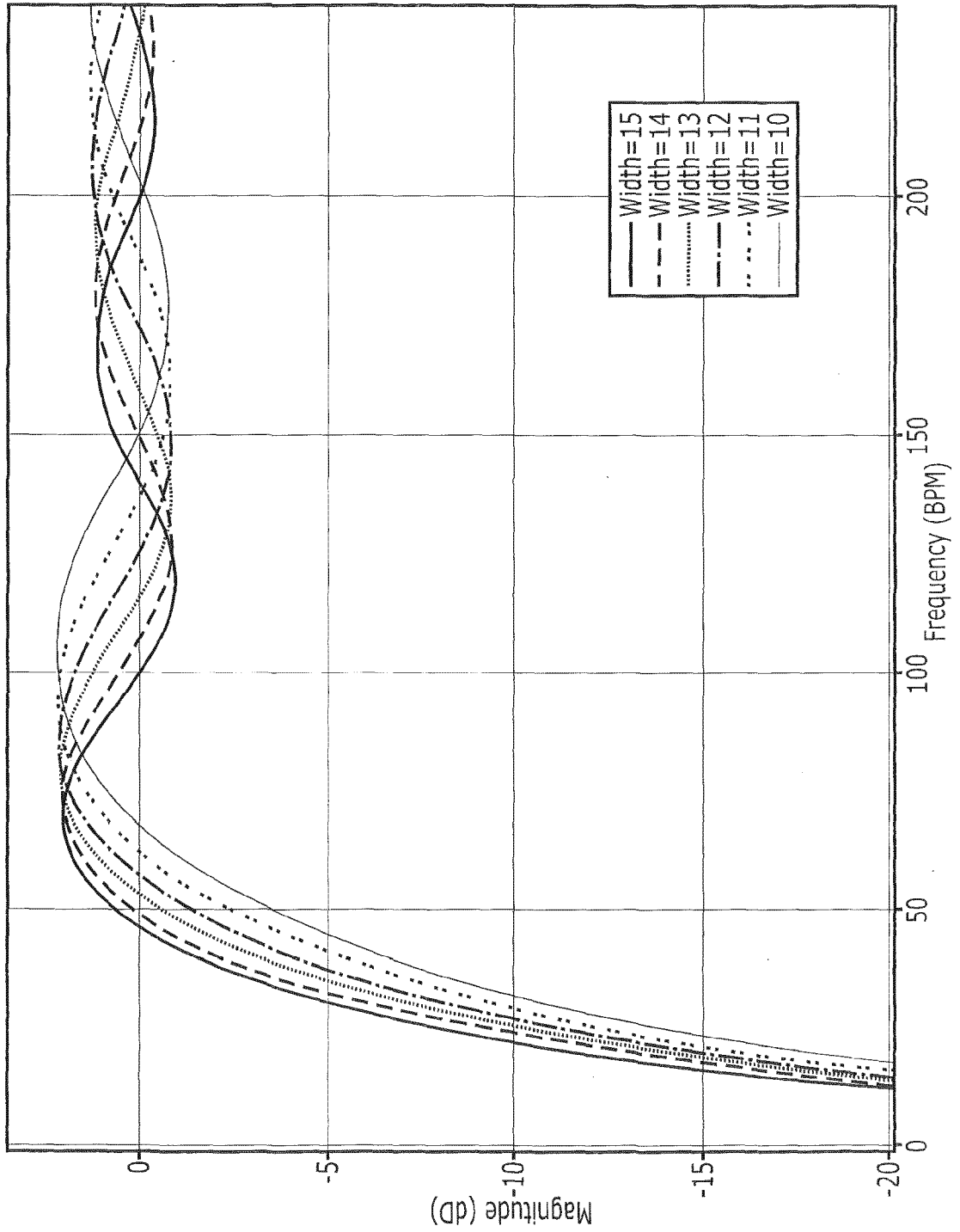

FIG. 8

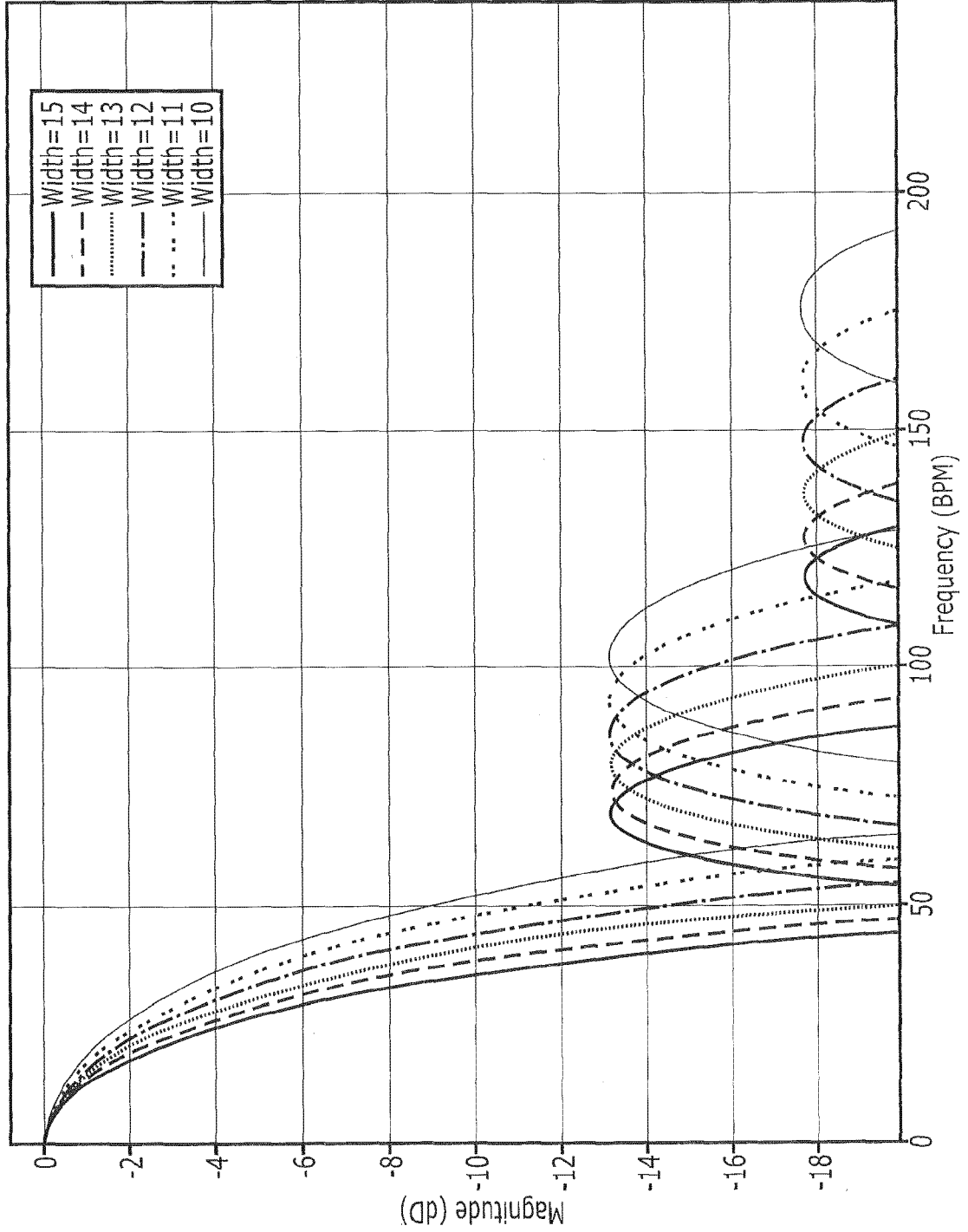

FIG. 9

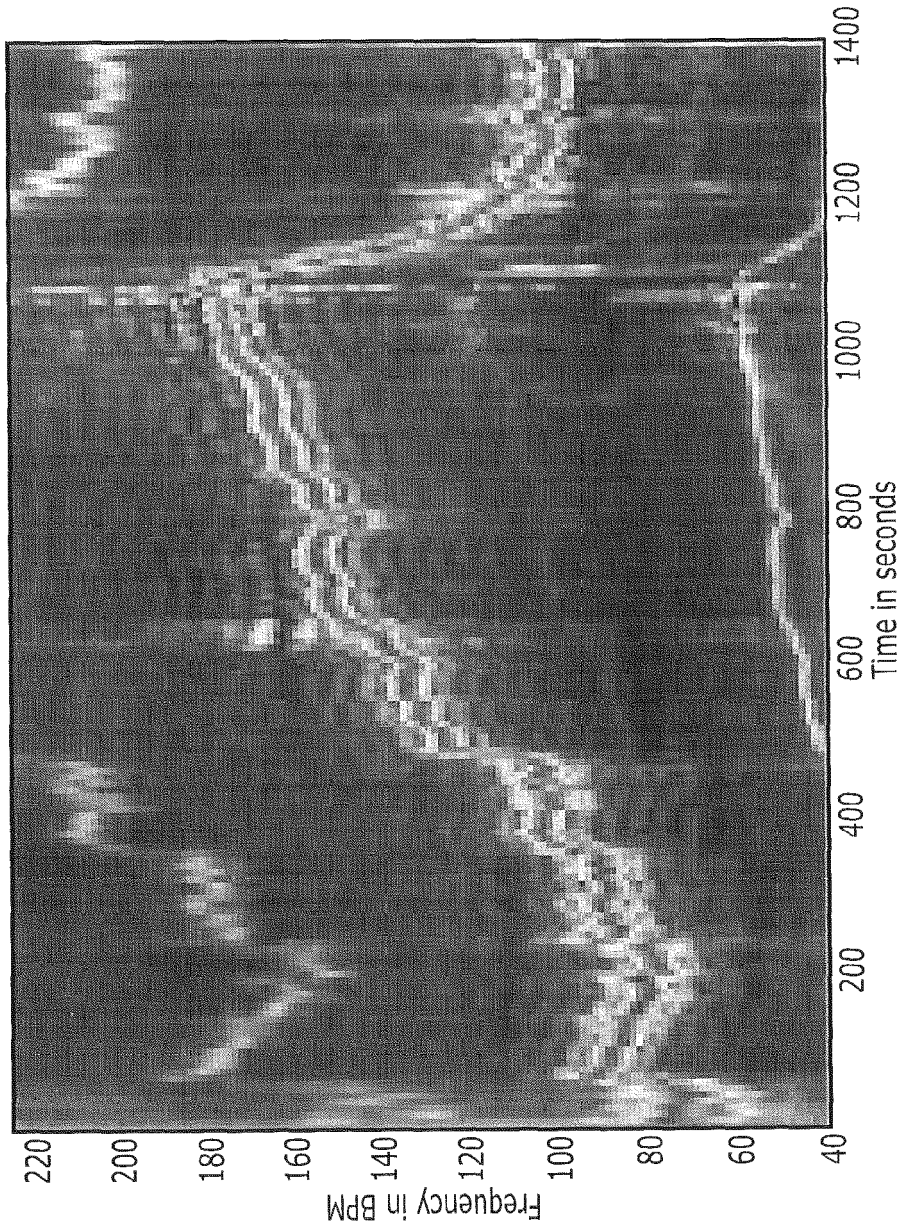

FIG. 10

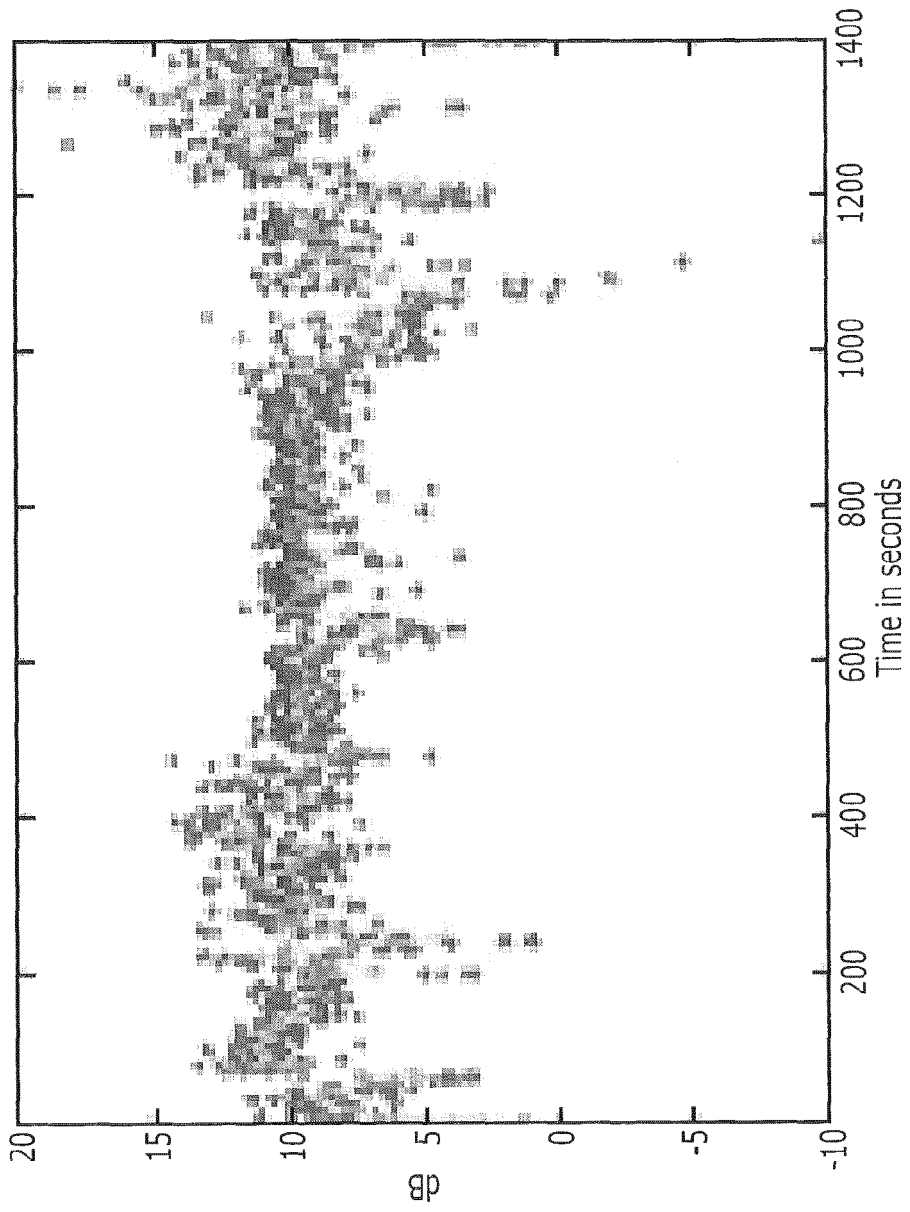

FIG. 11

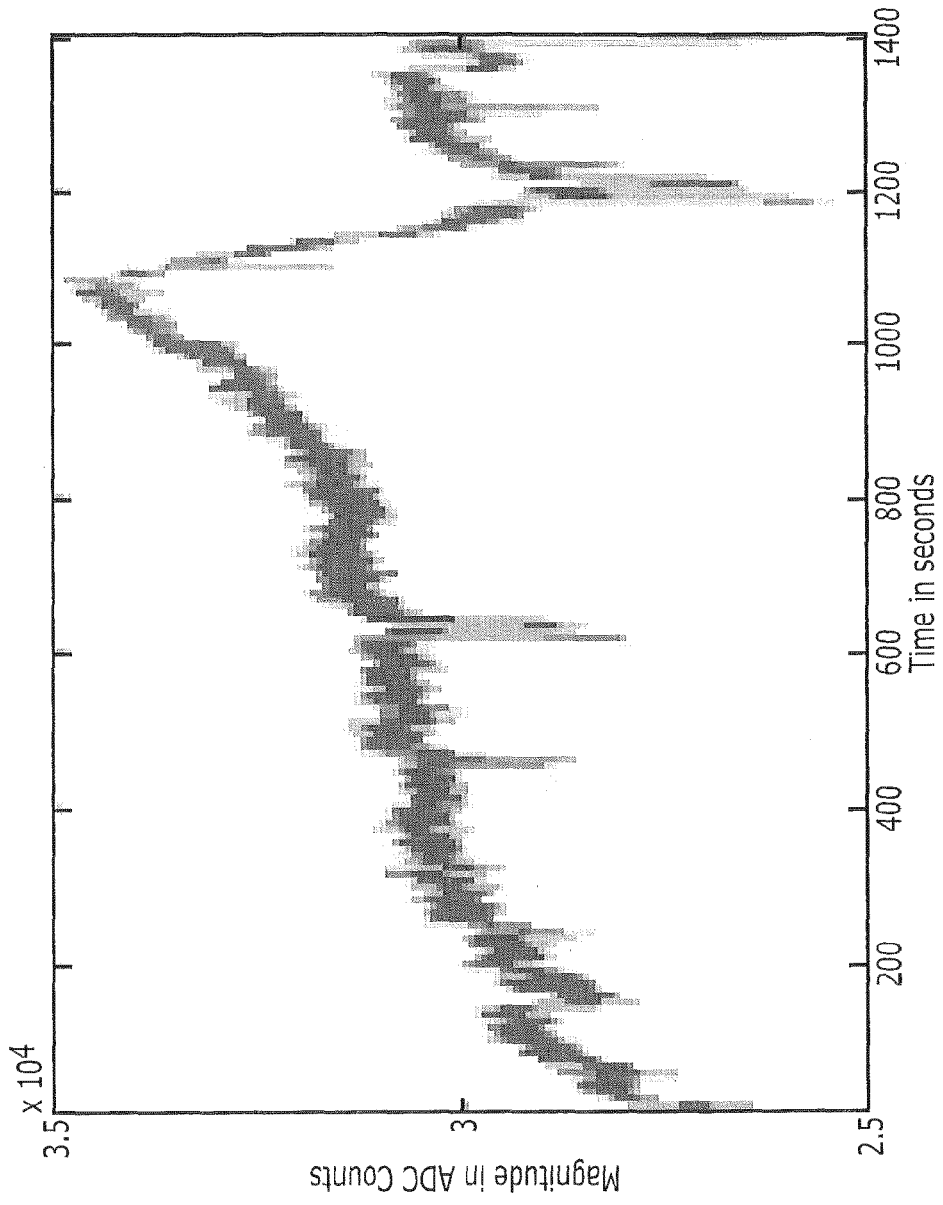

FIG. 12

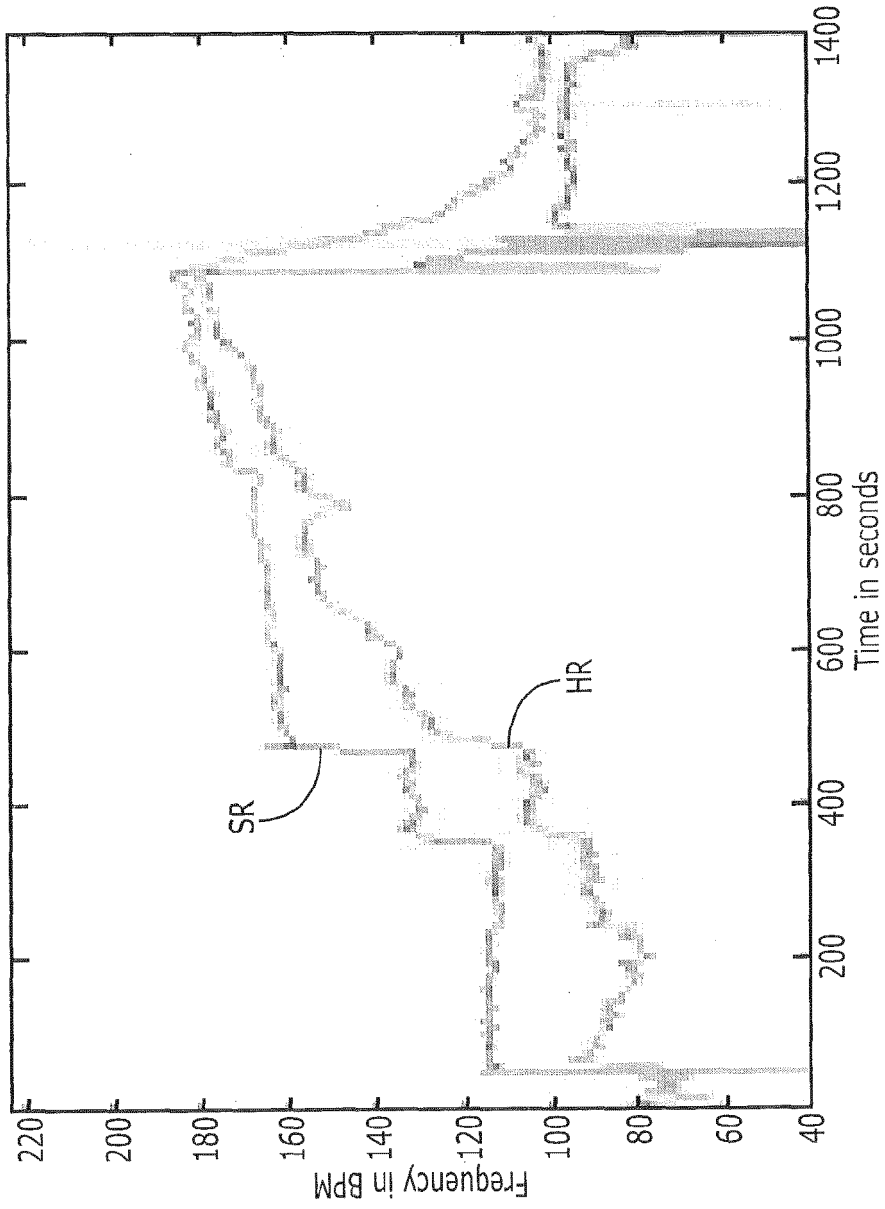

FIG. 13

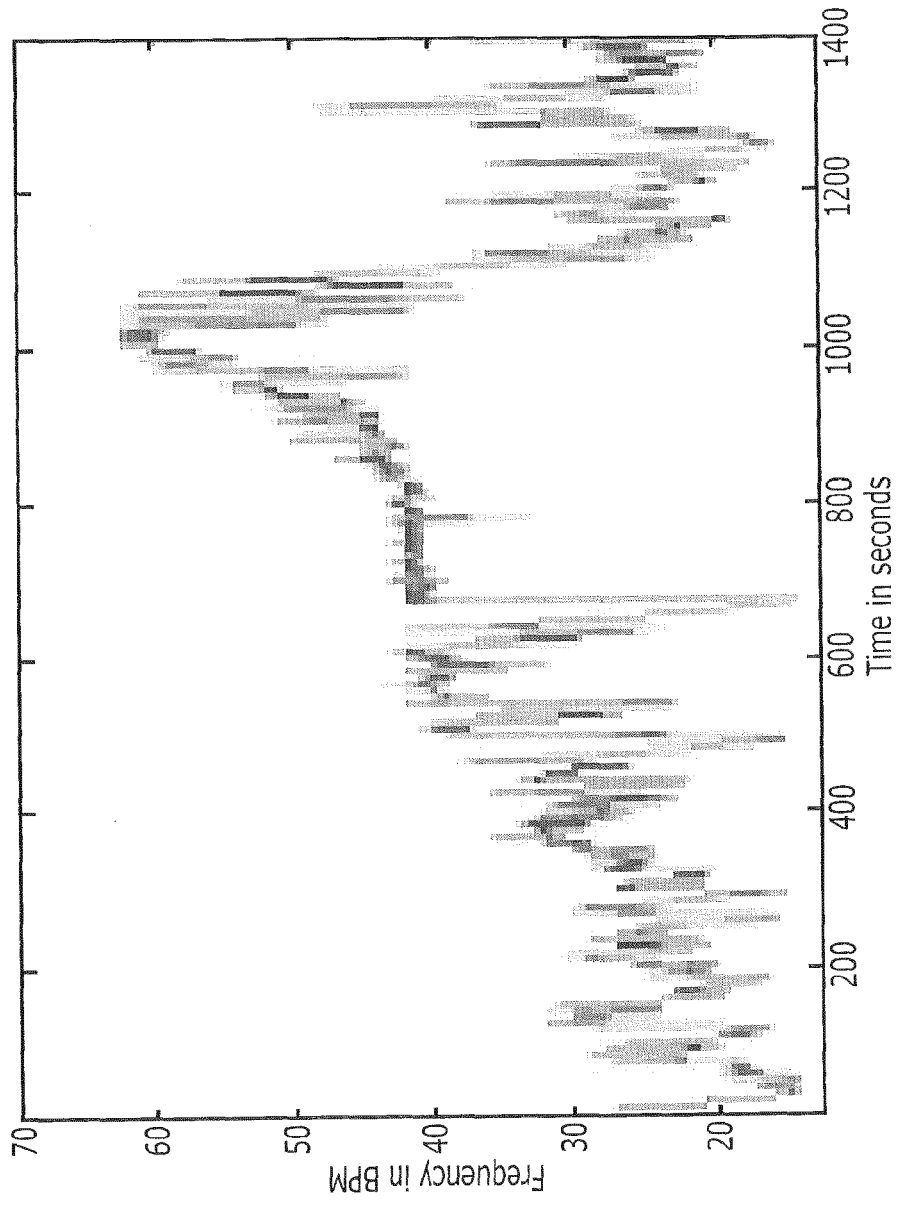

FIG. 14

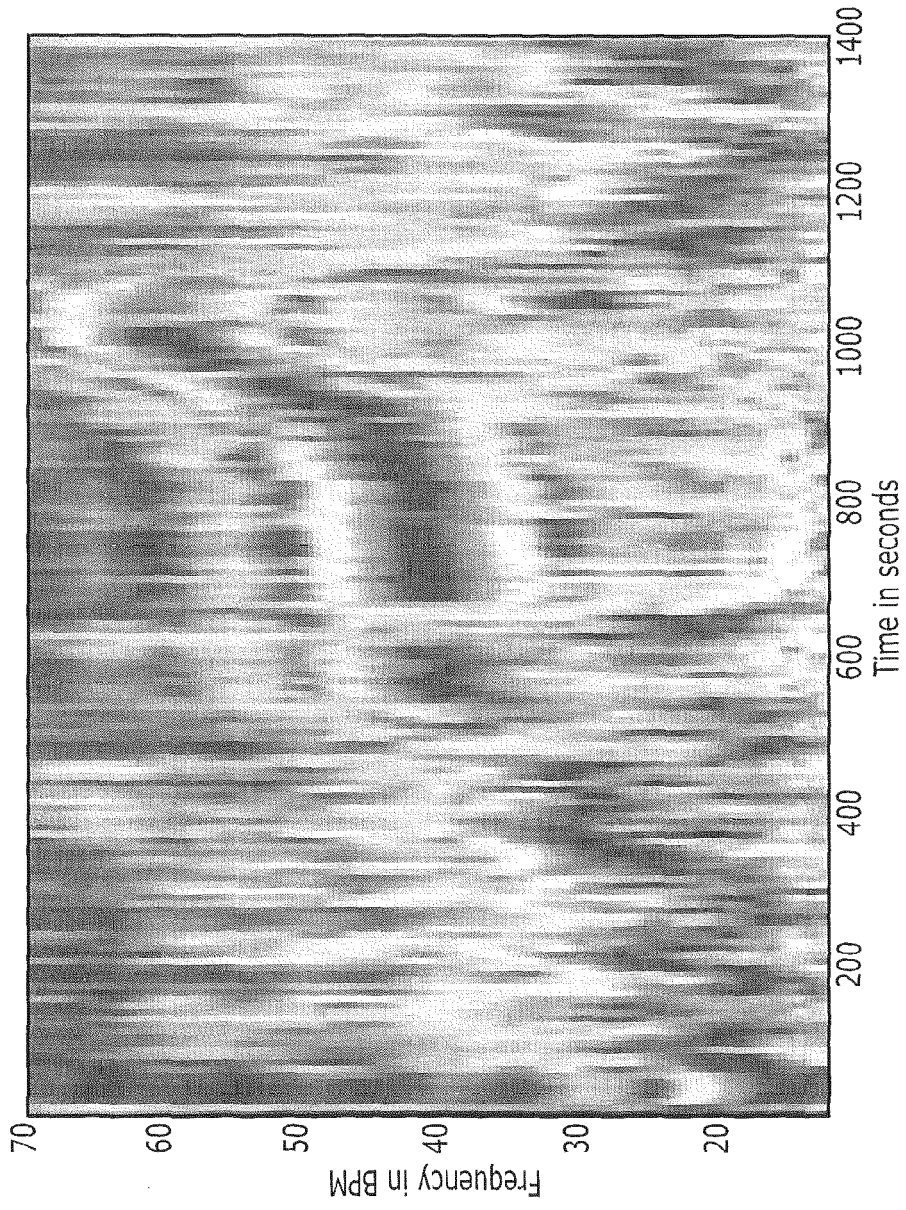

FIG. 15



EUROPEAN SEARCH REPORT

Application Number
EP 17 16 9569

5

10

15

20

25

30

35

40

45

50

55

DOCUMENTS CONSIDERED TO BE RELEVANT			
Category	Citation of document with indication, where appropriate, of relevant passages	Relevant to claim	CLASSIFICATION OF THE APPLICATION (IPC)
X	US 2004/133123 A1 (LEONHARDT STEFFEN [DE] ET AL) 8 July 2004 (2004-07-08) * paragraph [0025] * * figure 1 *	1-17	INV. A61B5/00 A61B5/04 A61B5/0205 A61B5/024 A61B5/0245 A61B5/0402 A61B5/0476 A61B5/08
X	US 2010/222655 A1 (STARR ERIC W [US] ET AL) 2 September 2010 (2010-09-02) * paragraph [0107] - paragraph [0122] *	1-17	
A	WO 02/17782 A2 (SQUID AG [DE]; STEINBERG FRITZ [DE]; FAINZELBERG LEONID [DE]) 7 March 2002 (2002-03-07) * abstract * * page 6, line 15 - page 10, line 20 * * figure 2 *	1-17	
			TECHNICAL FIELDS SEARCHED (IPC)
			A61B
The present search report has been drawn up for all claims			
Place of search The Hague		Date of completion of the search 23 August 2017	Examiner Van Dop, Erik
CATEGORY OF CITED DOCUMENTS X : particularly relevant if taken alone Y : particularly relevant if combined with another document of the same category A : technological background O : non-written disclosure P : intermediate document T : theory or principle underlying the invention E : earlier patent document, but published on, or after the filing date D : document cited in the application L : document cited for other reasons & : member of the same patent family, corresponding document			

EPO FORM 1503 03/02 (P04/C01)

ANNEX TO THE EUROPEAN SEARCH REPORT
ON EUROPEAN PATENT APPLICATION NO.

EP 17 16 9569

5 This annex lists the patent family members relating to the patent documents cited in the above-mentioned European search report.
The members are as contained in the European Patent Office EDP file on
The European Patent Office is in no way liable for these particulars which are merely given for the purpose of information.

23-08-2017

Patent document cited in search report	Publication date	Patent family member(s)	Publication date
US 2004133123 A1	08-07-2004	GB 2396426 A US 2004133123 A1	23-06-2004 08-07-2004
US 2010222655 A1	02-09-2010	US 7740591 B1 US 2010222655 A1 US 2014276120 A1	22-06-2010 02-09-2010 18-09-2014
WO 0217782 A2	07-03-2002	AU 8956901 A DE 10193581 D2 WO 0217782 A2	13-03-2002 17-07-2003 07-03-2002

REFERENCES CITED IN THE DESCRIPTION

This list of references cited by the applicant is for the reader's convenience only. It does not form part of the European patent document. Even though great care has been taken in compiling the references, errors or omissions cannot be excluded and the EPO disclaims all liability in this regard.

Patent documents cited in the description

- WO 61514099 A [0001]
- US 20100217102 A [0032]

专利名称(译)	用于通过心率度量反馈调整可变滤波器的系统和方法		
公开(公告)号	EP3222210A1	公开(公告)日	2017-09-27
申请号	EP2017169569	申请日	2012-07-25
[标]申请(专利权)人(译)	瓦倫賽爾公司		
申请(专利权)人(译)	VALENCELL INC.		
当前申请(专利权)人(译)	VALENCELL INC.		
[标]发明人	ROMESBURG ERIC DOUGLAS		
发明人	ROMESBURG, ERIC DOUGLAS		
IPC分类号	A61B5/00 A61B5/04 A61B5/0205 A61B5/024 A61B5/0245 A61B5/0402 A61B5/0476 A61B5/08		
CPC分类号	A61B5/0059 A61B5/0095 A61B5/0205 A61B5/02416 A61B5/0245 A61B5/04017 A61B5/0816 A61B5/7225 A61B5/725 A61B5/0402 A61B5/0476 A61B5/7278		
优先权	61/514099 2011-08-02 US		
外部链接	Espacenet		

摘要(译)

用于包括心血管信号分量的生理波形的生理信号处理系统提供响应于生理波形的可变高通滤波器，并且被配置为响应于所施加的转角频率对生理波形进行高通滤波。心率度量提取器响应于可变高通滤波器并且被配置为从高通滤波的生理波形中提取心率度量。转角频率调节器响应于心率度量提取器，并且被配置为基于所提取的心率度量来确定应用于可变高通滤波器的转角频率。还可以提供类似的方法。

