



(11) **EP 1 977 688 B1**

(12) **EUROPEAN PATENT SPECIFICATION**

(45) Date of publication and mention of the grant of the patent:  
**14.07.2010 Bulletin 2010/28**

(51) Int Cl.:  
**A61B 5/00 (2006.01)**

(21) Application number: **08006815.8**

(22) Date of filing: **03.04.2008**

(54) **Blood pressure monitoring apparatus and method**

Blutdrucküberwachungsvorrichtung und -verfahren

Appareil et procédé de surveillance de la pression artérielle

(84) Designated Contracting States:  
**DE FR GB NL**

(30) Priority: **04.04.2007 KR 20070033411**

(43) Date of publication of application:  
**08.10.2008 Bulletin 2008/41**

(73) Proprietor: **LG Electronics Inc.**  
**Seoul 150-721 (KR)**

(72) Inventors:  
• **Oh, Hyun Ho**  
**Seoul 137-724 (KR)**  
• **Shim, Bong Chu**  
**Seoul 137-724 (KR)**  
• **Lee, Youn Jae**  
**Seoul 137-724 (KR)**

- **Lee, Kwy Ro**  
**Seoul 137-724 (KR)**
- **Cho, Seong Moon**  
**Seoul 137-724 (KR)**
- **Hong, Hyung Ki**  
**Seoul 137-724 (KR)**

(74) Representative: **Urner, Peter**  
**TER MEER STEINMEISTER & PARTNER GbR**  
**Patentanwälte**  
**Mauerkircherstrasse 45**  
**81679 München (DE)**

(56) References cited:  
**WO-A-00/44274**                    **WO-A-02/33846**  
**WO-A-03/094720**            **WO-A-2007/017266**  
**US-A- 5 995 858**              **US-A1- 2002 193 692**  
**US-A1- 2007 016 086**

**EP 1 977 688 B1**

Note: Within nine months of the publication of the mention of the grant of the European patent in the European Patent Bulletin, any person may give notice to the European Patent Office of opposition to that patent, in accordance with the Implementing Regulations. Notice of opposition shall not be deemed to have been filed until the opposition fee has been paid. (Art. 99(1) European Patent Convention).

**Description**CROSS-REFERENCE TO RELATED APPLICATION

5 **[0001]** The present application is based on, and claims priority from, Korean Application Number 10-2007-0033411 filed April 4, 2007.

## BACKGROUND ART

10 **[0002]** The following description generally relates generally to a blood pressure monitoring apparatus and method.

**[0003]** Blood pressure is one of the most important vital signs used in the assessment of a (patient's) subject's cardiovascular health. In other words, the blood pressure is one of the most important biological index that contains various health-related information of a patient including cardiac output (CO) defined as the amount of blood ejected by the ventricles of the heart per minute (measured in liters per minute), vascular compliance and physiological changes.

15 **[0004]** There have been known two existing techniques for monitoring blood pressure, i.e., one is an invasive blood pressure monitoring method and the other is a non-invasive blood pressure monitoring method.

**[0005]** The invasive blood pressure monitoring method is such that a catheter is inserted into an artery and the blood pressure is continuously monitored. The advantage of the invasive blood pressure monitoring method is that the blood pressure can be accurately measured. However, this invasive method of monitoring blood pressure is associated with pains, discomfort and risks of complications to the subject such as infection, thrombosis and air embolism because the catheter must be inserted into an artery at all times.

20 **[0006]** Noninvasive measurement methods that provide continuous beat-to-beat blood pressure offers an alternative to invasive blood pressure monitoring because they do not carry with them the risk of complications associated with invasive monitoring as the noninvasive measurement methods measure blood pressure by applying pressure using a blood pressure cuff and monitoring the blood pressure by sound and vibration. However, this noninvasive measurement method has a disadvantage in that the blood pressure cannot be accurately measured and there are lots of errors involved, although blood pressure may be simply measured.

25 **[0007]** US 2002/01936 A1 describes a blood pressure monitoring apparatus having an ECG unit for detecting an electrocardiogram. Moreover, there is a photoelectric pulse wave detecting unit. The micro computer is calculating the blood pressure based on pulse wave signals generated by the photoelectric pulse wave unit, wherein the calculated blood pressure is displayed on a display device.

## SUMMARY

35 **[0008]** Thus, it is an object of the present disclosure to provide a blood pressure monitoring apparatus and method that can monitor an electrocardiogram signal and a pulse wave signal of a subject and the blood pressure of the subject safely and with high accuracy in continuous manner using the monitored electrocardiogram and pulse wave signals, body characteristic information and the body temperature of the subject without giving load on the subject.

**[0009]** Another object is to provide a blood pressure monitoring apparatus and method that can obviate the noise generated in the course of monitoring the pulse wave to improve a signal-to-noise (S/N) ratio, substantially reduce the power consumption and enhance the monitoring accuracy of the blood pressure.

40 **[0010]** According the objects of the instant novel concept, electrocardiogram signal and pulse wave signals of a subject are monitored. The electrocardiogram signal is monitored by using a plurality of electrocardiogram monitoring electrodes placed on the skin of a subject body.

45 **[0011]** The pulse wave signal is monitored in such a manner that a photoplethysmography (PPG) sensor generates a predetermined frequency of optical signal and emits the optical signal to a subject's body, where the signal is directed onto an area of the skin so that it penetrates or reflects from the tissue. This optical signal that has penetrated or reflected is received and converted to an electric signal. The converted electric signal is synchronized with a frequency band including a predetermined frequency to be removed of a noise signal, demodulated and filtered, whereby a pulse wave signal free of radio frequency is monitored.

50 **[0012]** A pulse wave propagation time is calculated using the detected electrocardiogram and pulse wave signals, the pulse wave signal is analyzed to calculate pulse wave analysis information, and the calculated pulse wave propagation time, pulse wave analysis information and body characteristic information of the subject are substituted into a predetermined regression equation to monitor the blood pressure.

55 **[0013]** The object is solved by the features of the independent claims.

**[0014]** Preferably, the electrocardiogram monitoring unit comprises: electrocardiogram monitoring electrodes monitoring an electric signal of the body by being brought into contact with the body; an electrocardiogram monitoring circuit monitoring an electrocardiogram signal by the electric signal monitored by the electrocardiogram monitoring electrodes

and outputting the signal to the micro computer.

[0015] In a preferred embodiment the PPG monitoring circuit comprises an analog-to-digital converter converting the pulse wave signal extracted by the pulse wave extractor and outputting the signal to the micro computer.

5 [0016] Preferably, the body characteristic information provided by the body characteristic information unit includes at least one or more of sex, weight, height, length of an arm and age of the subject.

[0017] Preferably, the pulse wave analysis information comprises: a pulse frequency (rate) of the subject monitored by the pulse wave signal; and a plurality of peak values of the acceleration waveform derived from second derivative of the pulse wave signal.

10 [0018] The object is also solved by a blood pressure monitoring apparatus which is integrated into one of a personal digital assistant (PDA), a portable multimedia player (PMP), a mobile communication terminal or an MP3 player.

[0019] The object is further solved by a mobile terminal including such blood pressure monitoring apparatus, as mentioned above, wherein the electrocardiogram monitoring electrodes are disposed at left and right lateral surfaces of a body of the mobile terminal and at an external lower surface of the mobile terminal, wherein the PPG sensor is disposed at an adjacent location of one electrocardiogram monitoring electrode disposed at the external lower surface. Alternatively, 15 the object is solved by a mobile terminal including such blood pressure monitoring apparatus, as mentioned above, wherein the electrocardiogram monitoring electrodes are disposed at on one lateral surface of the body of the mobile terminal and a further electrocardiogram monitoring electrode and the PPG sensor are disposed at the other lateral surface of the body of the mobile terminal.

20 BRIEF DESCRIPTION OF THE DRAWINGS

[0020] The general inventive concept now will be described more fully hereinafter with reference to the accompanying drawings, in which illustrative implementations of the concept are shown. This concept may, however, be implemented in many different forms and should not be construed as limited to the implementations set forth herein; rather, these 25 implementations are provided so that this disclosure will be thorough and complete, and will fully convey the scope of the concept to those skilled in the art. Like reference numerals refer to the same or similar elements throughout the drawings.

30 FIG.1 is a schematic block diagram illustrating an exemplary implementation of a blood pressure monitoring apparatus.

FIG.2 is a signal flowchart illustrating an exemplary implementation of a blood pressure monitoring method.

FIG.3 is a graph showing an electrocardiogram signal and a pulse wave signal.

FIG.4a is a schematic view of a representative electrocardiogram signal.

FIG.4b is a schematic view of a representative pulse wave signal.

35 FIG.4c is a schematic view of a second-derivative of acceleration waveform in a pulse wave signal.

FIGS.5a, 5b and 5c illustrate a construction of an exemplary implementation of a mobile communication terminal equipped with a blood pressure monitoring apparatus.

FIG.6 is a schematic block diagram illustrating another exemplary implementation of a blood pressure monitoring apparatus.

40 FIGS.7a to 7d illustrate waveforms of an output signal for each part of a photoplethysmography (PPG) monitoring unit in another exemplary implementation.

FIG.8 is a schematic view of a signal to noise ratio relative to a power consumption of a blood pressure monitoring apparatus in another exemplary implementation.

45 FIG.9 is a schematic block diagram illustrating a construction of still another exemplary implementation of a blood pressure monitoring apparatus.

FIG.10 is a schematic block diagram illustrating a construction of still another exemplary implementation of a blood pressure monitoring apparatus.

50 DETAILED DESCRIPTION

[0021] Implementations disclosed hereunder are exemplary only and not intended to be limiting, and serve to explain the principles and novel concept of the instant teaching and to enable a person skilled in the pertinent art(s) to make and use the teaching. For the purpose of clarity, technical material that is known in the technical fields related to the teaching has not been described in detail so that the teaching is not unnecessarily obscured. The teaching is susceptible 55 to various modifications and alternative forms, and specific implementations thereof are shown by way of example in the drawings.

[0022] FIG.1 is a schematic block diagram illustrating an exemplary implementation of a blood pressure monitoring apparatus, where reference numeral 100 defines an electrocardiogram monitoring unit for detecting an electrocardiogram

signal of a subject.

[0023] The electrocardiogram monitoring unit 100 may be operated in such a way that electrocardiogram monitoring electrodes 102 are placed on the skin of a subject's body to detect an electric signal of the body. The electric signal of the body detected by the electrocardiogram monitoring electrodes 102 may be inputted to an electrocardiogram monitoring circuit 104 to detect an electrocardiogram of the subject.

[0024] Reference numeral 110 defines a photoplethysmography (PPG) monitoring unit for detecting a pulse wave of the subject. The photoplethysmography (PPG) monitoring unit 110 may be operated in such a manner that a PPG sensor 112 (i.e., PPG finger sensor and PPG ear sensor) is placed on a subject's body, i.e., fingers or ears, to sense the PPG signal of the subject. The PPG signal sensed by the PPG sensor 112 may be inputted to a PPG monitoring circuit 114, whereby a pulse wave signal is monitored.

[0025] Reference numeral 120 is a body characteristic information input unit. The body characteristic information input unit 120 may include, for instance, a plurality of functional keys, and the body characteristic information of a subject that needs measurement of blood pressure is inputted by manipulation of the functional keys. The body characteristic information may include, but not limited to, at least any one or more of sex, weight, height, length of an arm and age of a subject.

[0026] Reference numeral 130 is a micro computer. The micro computer 130 may use the electrocardiogram signal monitored by the electrocardiogram monitoring unit 100 and the pulse wave signal monitored by the PPG monitoring unit 110 to calculate a pulse transit time and pulse wave analysis information. Furthermore, the micro computer 130 may plug the body characteristic information inputted from the body characteristic information input unit 120, the pulse wave propagation time and the pulse wave analysis information in a predetermined regression equation to calculate the blood pressure.

[0027] Reference numeral 140 is storage. The storage 140 may store the blood pressure calculated by the micro computer 130 under the control of the micro computer 130. Furthermore, the storage 140 may store respective body characteristic information of a plurality of subjects inputted from the body characteristic information input unit 120 under the control of the micro computer 130.

[0028] If the body characteristic information of the subject is stored in the storage 140 beforehand, the subject stored in the storage 140 may be selected by the manipulation of the functional keys of the body characteristic information input unit 120, and the body characteristic information of the selected subject may be read from the storage 140 and used. Reference numeral 150 is a display unit for allowing the blood pressure calculated by the micro computer 130 to be displayed for visual checks.

[0029] FIG.2 is a signal flowchart illustrating an exemplary implementation of a blood pressure monitoring method.

[0030] Referring to FIG.2, when the blood pressure is to be monitored, the micro computer 130 may input from the body characteristic information input unit 120 the body characteristic information of a subject from whom blood pressure is to be monitored. The body characteristic information may include, but not limited to, at least any one or more of sex, weight, height, length of an arm and age of a subject.

[0031] The body characteristic information may be inputted by manipulation of the plurality of functional keys disposed at the body characteristic information input unit 120.

[0032] The micro computer 130 may input the electrocardiogram signal monitored by the electrocardiogram monitoring unit 100 and the pulse wave signal monitored by the PPG monitoring unit 110 (S202).

[0033] Once the electrocardiogram signal and the pulse wave signal are inputted, the micro computer 130 uses the electrocardiogram signal and the pulse wave signal to calculate the pulse wave propagation time (S204). The pulse wave propagation time is a time for the blood starting from the heart to reach a peripheral structure such as a finger tip or a toe tip, and may be obtained by R wave of the electrocardiogram signal and pulse wave signal. The detailed operation of calculating the pulse wave propagation time will be described later. A relation between the blood pressure and the pulse wave propagation time may be expressed by the following equation 1.

**【Equation 1】**

$$c = \sqrt{\frac{V}{\delta(\partial V / \partial P)}} = \sqrt{\frac{V}{\delta} \frac{\partial P}{\partial V}}$$

where, c is a pulse wave velocity obtained by dividing a distance between the heart and the finger tip by a pulse wave propagation time,  $\delta$  is blood density, V is blood volume and P is blood pressure. Assuming that the blood density  $\delta$  is constant, the Equation 1 may be simply expressed by the following Equation 2.

## 【Equation 2】

$$\Delta P \propto c^2 \left( \frac{\Delta V}{V} \right)$$

where,  $\Delta P$  is a substitution of  $\partial P$ , and  $\Delta V$  is a substitution of  $\partial V$ .

**[0034]** As noted from the Equation 2, the blood pressure is proportional to changes of the pulse wave velocity and the blood volume, and the pulse wave velocity is equal to a value where a distance between the heart and the finger tip is divided by the pulse wave propagation time, where it can be noted that the blood pressure may be estimated by the pulse wave propagation time and the blood volume.

**[0035]** If the pulse wave propagation time is calculated, the micro computer 130 may analyze the pulse wave signal inputted from the PPG monitoring unit 110 to calculate the pulse wave analysis information (S206). The detailed operation of obtaining the pulse wave analysis information will be described later.

**[0036]** Once the pulse wave propagation time and the pulse wave analysis information are calculated, the micro computer 130 may substitute the body characteristic information of the subject, the pulse wave propagation time and the pulse wave analysis information into a predetermined regression equation to calculate the blood pressure (S208, S210). Once the blood pressure is calculated, the micro computer 130 may store the calculated blood pressure in the storage 140 for management, and display the blood pressure on the display unit 140 for visual checks (S212).

**[0037]** Now, the blood pressure monitoring apparatus will be described in detail with reference to FIGS.3, 4a and 4b.

**[0038]** FIG.3 is a graph showing an electrocardiogram signal and a pulse wave signal, FIG.4a is a schematic view of a representative electrocardiogram signal monitored by an electrocardiogram monitoring unit 100, and FIG.4b is a schematic view of a representative pulse wave signal monitored from a finger tip of a subject.

**[0039]** Referring to FIG.4a, the electrocardiogram signal may be divided to a P-wave, a Q-wave, an R-wave, an S-wave and a T-wave according to location of a peak point. The R-wave is a wave detected from a point where blood is charged from heart. The changes of blood volume are generated by repeated diastole and systole of the heart. The PPG monitoring unit 110 may monitor a pulse wave signal that is changed by the changes of blood volume as shown in FIG.4b.

**[0040]** The micro computer 130 may employ the R-wave of the electrocardiogram signal and the pulse wave signal to obtain the pulse wave propagation time. In order to monitor the pulse wave propagation time, a certain point from the pulse wave signal must be set up as a reference point. The pulse wave propagation time may be calculated by a time between the R-wave of the electrocardiogram signal and the reference point of the set-up pulse wave signal.

**[0041]** For example, as illustrated in FIG.3, a peak point of the pulse wave signal may be set up as a reference point (REF1), and a time between the set-up reference point (REF1) and the R-wave of the electrocardiogram signal may be determined as the pulse wave propagation time (PTT1). Alternatively, a peak point derived from first derivative of the pulse wave signal may be set up as the reference point (REF2) and a time between the set-up reference point (REF2) and the R-wave of the electrocardiogram signal may be determined as the pulse wave propagation time (PPT2). Alternatively, a peak point derived from second derivative of the pulse wave signal may be set up as a reference point (REF3) and a time between the set-up reference point (REF3) and the R-wave of the electrocardiogram signal may be determined as the pulse wave propagation time (PPT3).

**[0042]** Furthermore, the pulse wave analysis information may be acquired by analyzing waveforms of the pulse wave signal. FIGS. 4c is a schematic view of a second-derivative of acceleration waveform in a pulse wave signal.

**[0043]** The acceleration waveform in a pulse wave signal is well known art from Kenji Takazawa (American Heart Association, 1998). The micro computer 130 may use values of peak points in the second derivative of acceleration waveform in the pulse wave signal or time differences generated by the peak points to calculate the degree of aging of blood vessel or age of the blood vessel.

**[0044]** The micro computer 130 may divide the values of each peak point to a, b, c, d and e, as illustrated in FIG.4c, and the divided a, b, c, d and e values are employed to calculate the degree of aging of blood vessel or the aging of the blood vessel.

**[0045]** For example, the micro computer 130 may calculate the degree of aging of blood vessel or the aging of the

blood vessel using  $\frac{-b+c+d+e}{a}$

The method of calculating the degree of aging of blood vessel or the aging of the blood vessel using the acceleration waveform of pulse wave signal is known art, such that there will be no further explanation thereto.

[0046] The micro computer 130 may take the simple derivative with respect to the pulse wave signal and uses a time between the peak points of the first derivative of the pulse wave signal to calculate the pulse frequency (rate). Furthermore, the micro computer 130 may perform the second derivative of the pulse wave signal for conversion to the acceleration waveform and extract values of each peak point, i.e., a, b, c, d and e from the acceleration waveform in the pulse wave signal.

[0047] The micro computer 130 may use the pulse frequency and the values of the peak points, i.e., a, b, c, d and e, as the pulse wave analysis information to calculate the blood pressure. If thrombi are accumulated on walls of the blood vessel, a passage through which blood can pass is relatively narrowed, whereby resistance increases to have an effect on the blood pressure, such that the blood pressure may be calculated in consideration of blood states (degree of aging in blood vessel or ages of blood vessel).

[0048] The pulse wave signal (i.e., the pulse wave signal monitored from a finger tip) may be affected by the strength of force applied to the PPG sensor 112. The influence to the PPG sensor may be analyzed and solved by the patterns of the monitored pulse wave signal. Alternatively, a pressure sensor may be installed underneath the PPG sensor 112, such that the subject is induced to apply a predetermined force to the PPG 112 and to monitor the pulse wave signal.

[0049] Meanwhile, the peripheral structures such as legs, hands or feet of the body may sustain changes in body temperature due to decrease in the amount of blood flow. The pulse wave signal may not be monitored well if temperature is low at a location from which the pulse wave signal is to be monitored, i.e., the finger tip.

[0050] Accordingly, a separate temperature sensor is installed adjacent the PPG sensor 112 to allow the PPG sensor 112 to monitor the temperature at the finger tip from which the pulse wave signal is to be monitored, and the monitored temperature may be used as a factor for calculating the blood pressure.

[0051] Furthermore, if a temperature lower than the normal body temperature, i.e., lower than 35.5 degrees Celsius, is monitored, the subject is induced to rub or massage a body part having a particular lower temperature and to increase the temperature of the body part up to an average temperature, where the pulse wave signal may be monitored.

[0052] The micro computer 130 may use as a predetermined factor for regression equation for calculation of the blood pressure the body characteristic information including, but not limited to, at least any one or more of sex, weight, height, length of an arm and age of a subject. The micro computer 130 may plug the pulse wave propagation time, the pulse wave analysis information, the body characteristic information and the body temperature in the regression equation of the following Equation 3 to calculate the blood pressure (P).

**[Equation 3]**

$$\text{Blood pressure (P)} = k_1 * \text{pulse wave propagation time} + \sum_i k_{2i} * \text{pulse wave analysis information} + \sum_j k_{3j} * \text{body characteristic information} + k_4 * \text{body temperature,}$$

where  $k_1$ ,  $k_{2i}$ ,  $k_{3j}$  and  $k_4$  define coefficient values respectively corresponding to the pulse wave propagation time, the pulse wave analysis information, the body characteristic information and the body temperature monitored from the regression analysis, which are predetermined values that are experimentally obtained.

[0053] Although the body temperature may not be plugged in the Equation 3 to calculate the blood pressure, it is preferred that the body temperature be plugged in for an accurate calculation of the blood pressure. Furthermore, if the subject is induced to monitor the pulse wave signal by rubbing or massaging a body part, i.e., the finger tip, having a particular lower temperature and increasing the temperature of the body part up to an average temperature, the body temperature may not be inserted into the Equation 3 to calculate the blood pressure.

[0054] The blood pressure monitoring apparatus according to the instant novel concept may be configured in an independent blood pressure monitoring device. Furthermore, the blood pressure monitoring apparatus may be used as an integral part of a hand-held terminal such as a personal digital assistant (PDA), a portable multimedia player (PMP), a mobile communication terminal or an MP3 player.

[0055] When the blood pressure monitoring apparatus is integrally mounted in the mobile communication terminal, the micro computer 130 may be replaced by a micro computer disposed inside the mobile communication terminal. For example, a mobile communication terminal is disposed with a micro computer performing a function of processing one or more digital signals. As a result, the micro computer disposed in the mobile communication terminal may be embodied to monitor the blood pressure utilizing the body characteristic information, the electrocardiogram signal and the pulse

wave signal. Furthermore, the body characteristic information input unit 120, the storage 140 and the display unit 150 disposed in the blood pressure monitoring apparatus may be respectively replaced for use by a key pad, a memory and a display unit mounted in the mobile communication terminal. In doing so, the blood pressure may be accurately monitored at a lower cost using the mobile communication terminal.

5 **[0056]** FIGS.5a, 5b and 5c illustrate a construction of an exemplary implementation of a mobile communication terminal equipped with a blood pressure monitoring apparatus.

**[0057]** Referring to FIGS.5a, 5b and 5c, electrocardiogram monitoring electrodes 102a, 102b, 102c in the blood pressure monitoring apparatus may be respectively disposed at left and right lateral surfaces of a body of the mobile communication terminal and external lower surface of a folder 502. The PPG sensor 112 may be disposed at an adjacent location of the electrocardiogram monitoring electrode 102c disposed at an external lower surface of the folder 502.

10 **[0058]** Under these circumstances, when a subject may grasp to wrap a body 500 of the mobile communication terminal with one hand, two fingers, i.e., a thumb and an index finger may be brought into contact with the electrocardiogram monitoring electrodes 102a, 102b at the left and right lateral surfaces of the body. Another finger, i.e., a middle finger, may be brought into contact with both the electrocardiogram monitoring electrodes 102c at the lower part of the folder 502 and the PPG sensor 112 to simultaneously monitor the electrocardiogram signal and the pulse wave signal.

15 **[0059]** Although it is not illustrated in the drawings, a left lateral surface of the body of the mobile communication terminal may be disposed with the electrocardiogram monitoring electrodes 102a, 102b, and the right lateral surface of the body of the mobile communication terminal may be disposed with the remaining electrocardiogram monitoring electrode 102c and the PPG sensor 112. Under these circumstances, each finger, i.e., index fingers from both hands) of the subject may be brought into contact with the electrocardiogram monitoring electrodes 102a, 102b, 102c and the PPG sensor 112 to allow monitoring the pulse wave signal. The number of electrocardiogram monitoring electrodes that are used for monitoring the pulse wave signal may be three, or may be two. The locations of electrocardiogram monitoring electrodes 102a, 102b, 102c and the PPG sensor 112 may be changed according to the configuration of the mobile communication terminal.

25 **[0060]** When the blood pressure monitoring apparatus is integrally mounted in the mobile communication terminal, the electrocardiogram signal, the pulse wave signal and the blood pressure of a subject may be monitored using the mobile communication terminal. Furthermore, a user interface, an operating function and display function of the mobile communication terminal may be utilized to monitor the electrocardiogram signal, the pulse wave signal and the blood pressure of a subject and to display on the display unit 150, whereby a health status of a subject may be automatically checked. Still furthermore, the electrocardiogram signal, the pulse wave signal and the blood pressure of a subject may be utilized to provide a predetermined service including, but not limited to, a moody music such as classic music when the blood pressure or the stroke of pulse increases, a text message notifying a health state or a voice service.

30 **[0061]** In the blood pressure monitoring apparatus and method in the foregoing exemplary implementations, the PPG sensor 112 may generate noise signals amid the monitoring of the pulse wave signal, and the generated noise signals may increase the power consumption, resulting in an inaccurate monitoring of the pulse wave signal and subsequently an inaccurate measurement of the blood pressure. Therefore, the noise signals are preferably removed that are generated in the course of monitoring of the pulse wave signals to accurately detect the blood pressure.

35 **[0062]** Now, exemplary implementations of the blood pressure monitoring apparatus and method capable of removing noise signals generated from the monitoring of the pulse wave signal to reduce the power consumption, and enhancing the signal-to-noise (S/N) ratio will be described in detail with reference to FIGS.6 to 10.

40 **[0063]** FIG.6 is a schematic block diagram illustrating another exemplary implementation of a blood pressure monitoring apparatus, wherein the PPG sensor 112 comprises a light emitting device driving unit 600, an optical signal transmitter 602 and an optical signal receiver 604.

45 **[0064]** The light emitting device driving unit 600 may drive an optical device (not shown) disposed at the optical signal transmitter 602 to output an optical signal in response to an oscillation signal of a particular frequency (fm) outputted by the micro computer 130. For example, the micro computer 130 may generate an oscillation signal having a frequency (fm) of 300 MHz or more, whereby the light emitting device driving unit 600 drives the optical device of the optical signal transmitter 602 to generate an optical signal in response to the oscillation signal.

50 **[0065]** The optical device of the optical signal transmitter 602 may use, for example, a near infrared generating light emitting diode for generating the near infrared to generate the optical signal. The optical signal outputted from the optical signal transmitter 602 is emitted toward a subject. The optical signal outputted from the optical signal transmitter 602 is not the general direct current optical signal but an optical signal of a particular frequency generated by the micro computer 130 for removing the noise. For example, the optical signal generated by the optical signal transmitter 602 is an optical signal having a frequency (fm) of 300 MHz or more.

55 **[0066]** Therefore, even if part of the optical signal outputted from the optical signal transmitter 602 is absorbed by the body of a subject, and the remaining of the optical signal penetrates or is reflected from the body, the penetrated or reflected optical signal still holds the particular frequency (fm).

**[0067]** The optical signal of a particular frequency that has penetrated or reflected from the body may be received by

the optical signal receiver 604 and converted to an electric signal, and the converted electric signal may be outputted to the PPG monitoring circuit 114. The optical signal receiver 604 may be a photo diode or a phototransistor. The photo diode or phototransistor may convert the optical signal of a particular frequency (fm) received by the photo diode or the phototransistor to a current signal of a particular frequency, where the current signal may be outputted to the PPG monitoring circuit 114.

**[0068]** The PPG monitoring circuit 114 may include a current/voltage converter 610, a tuned amplifier 612, a pulse wave extractor 614 and analog-to-digital (A/D) converter 616, where the pulse wave extractor 614 may include a demodulator 614a and a lowpass filter 614b.

**[0069]** The current signal of a particular frequency outputted by the optical signal receiver 604 may be converted to a voltage signal of a particular frequency by the current/voltage converter 610 of the PPG monitoring circuit 114 and inputted to the tuned amplifier 612.

**[0070]** The signal of a particular frequency outputted by the current/voltage converter 610 may be tuned and amplified by the tuning amplifier 612.

It should be noted that only a signal of particular frequency out of the signals outputted from the current/voltage converter 610 may be tuned by the tuned amplifier 612, while a signal having no particular frequency, i.e., noise signal, may not be tuned by the tuning amplifier 612 but be removed of the noise signal.

**[0071]** The output signal of the tuning amplifier 612 is inputted to the demodulator 614a of the pulse wave extractor 614, where the demodulator 614a may multiply the output signal of the tuning amplifier 612 by an oscillation signal of a particular frequency outputted from the micro computer 130 and demodulated.

**[0072]** The output signal of the demodulator 614a may be filtered by the lowpass filter 614b to be removed of the noise signal from where a pulse wave signal is monitored. The monitored pulse wave signal may be converted to a digital signal by the A/D converter 616 to be inputted to the micro computer 130. The A/D converter 616 may be integrally mounted in the micro computer 130.

**[0073]** In other words, the blood pressure monitoring apparatus according to another exemplary implementation is configured in such a manner that a noise signal is initially removed by the tuning amplifier 612 when monitoring the pulse wave signal, and the noise signal may be secondly removed by the pulse wave extractor 614 to be converted to the digital signal by the A/D converter 616 and inputted to the micro computer 130. Therefore, the noise signal generated in the course of monitoring the pulse wave signal can be removed to reduce the consumed power and to enhance the signal-to-noise ratio.

**[0074]** If the micro computer 130 is integrally disposed with the function of converting the analog signal to the digital signal, the A/D converter 616 may not be disposed in the PPG monitoring circuit, and the output signal of the lowpass filter 614b may be directly inputted to the micro computer 130.

**[0075]** The electrocardiogram monitoring unit 100 may monitor the electrocardiogram signal of the subject and input to the micro computer 130, and the body characteristic information input unit 120 may input the body characteristic information of the subject to the micro computer 130 according to manipulation of a user.

**[0076]** Successively, the micro computer 130 may utilize the pulse wave signal and the electrocardiogram signal of the subject to calculate the pulse wave propagation time and the pulse wave analysis information, where the calculated pulse wave propagation time, the pulse wave analysis information and body characteristic information are plugged in the Equation 3 to monitor the blood pressure of the subject.

**[0077]** Once the blood pressure of the subject is monitored, the micro computer 130 may store and manage the monitored blood pressure in the storage 140 and display on the display unit 150 to allow a user to check.

**[0078]** The present novel concept may be used as a bio-signal monitoring apparatus for monitoring various bio-signals of a subject by using the pulse wave signal monitored by the PPG monitoring circuit 114. For example, the micro computer 130 may use the pulse wave signal to monitor not only the basic bio signals but body fat, body water, body heat, body composition and bone mineral density (BMD), and may be widely used for monitoring sugar content in fruits, an inner composition analysis of a plant or discrimination of various kinds of materials. To this end, the micro computer 130 in the instant novel concept may be mounted with various systems such as arithmetic algorithm, database and lookup table for providing results derived from various kinds of detections (pulse wave signals inputted to the micro computer 130), so that a variety of detection values may be comprehensively realized.

**[0079]** A blood pressure monitoring apparatus according to another exemplary implementation may remove the direct current offset or outside optical noise. i.e., fluorescent lamp noise of 60Hz or high frequency noises of 120Hz, using the PPG monitoring circuit 114 without causing any distortion to the pulse wave signal. Because the pulse wave signal is monitored with the noises being separated, a high signal-to-noise ratio may be maintained even if the intensity of optical signal outputted by the optical signal transmitter 602 in the PPG sensor 112 is low.

**[0080]** Furthermore, reduced power consumption in the optical signal transmitter 602 (where most of the power is consumed in the blood pressure monitoring apparatus) may enable a markedly reduced overall consumption of power in the blood pressure monitoring apparatus, whereby a low capacity battery may be used to increase the portability of the apparatus.

[0081] FIGS.7a to 7d illustrate waveforms of an output signal for each part of a photoplethysmography (PPG) monitoring unit in another exemplary implementation.

[0082] The light emitting device driving unit 600 may drive the optical device of the optical signal transmitter 602 to generate an optical signal having a predetermined frequency ( $f_m$ ) in response to the predetermined frequency ( $f_m$ ) outputted from the micro computer 130, and the generated optical signal penetrates or is reflected from the body of a subject. The optical signal that has penetrated or been reflected from the body may be received by the optical signal receiver 604 and converted to an electric signal. The signal outputted by the optical signal receiver 604 is a current signal, which is in turn converted to a voltage signal by the current/voltage converter 610 of the PPG monitoring circuit 114.

[0083] Referring to FIG.7a, the voltage signal converted by the current/voltage converter 610 may include various mixed noise signals including a direct current offset noise signal, an outside optical noise signal (i.e., 60Hz or 120Hz) besides the optical signal (the optical signal reflected from the body) converted to a predetermined frequency ( $f_m$ ).

[0084] The optical signal transmitter 602 in the instant novel concept may generate an optical signal having a predetermined frequency ( $f_m$ ), i.e., a frequency of 300Hz or more, to allow the optical signal having the predetermined frequency ( $f_m$ ) to be separated from the generated noise signals.

[0085] The output signal of the current/voltage converter 610 is inputted to the tuned amplifier 612 to be tuned and amplified. The tuning frequency scope of the tuned amplifier 612 may include the predetermined frequency as shown in FIG.7b. The signal having the predetermined frequency ( $f_m$ ) in the output signal of the current/voltage converter 610 is tuned and amplified by the tuned amplifier 612, and the direct current offset noise signal and the outside optical noise signal in the output signal of the current/voltage converter 610 are not tuned only to be removed thereafter.

[0086] The signal tuned by the tuned amplifier 612 may be outputted without being amplified, or may be outputted by being amplified as much as a predetermined magnification factor. The amplification in the tuned amplifier 612 is to enhance the quantization precision when the signal inputted to the micro computer 130 is converted to a digital signal.

[0087] The signal tuned by the tuned amplifier 612 is inputted to the demodulator 614a and demodulated as illustrated in FIG.7c. The demodulator 614 may be, for example, a mixer, where the demodulation is performed by multiplying the output signal of the tuned amplifier 612 by the signal of a predetermined frequency ( $f_m$ ) outputted by the micro computer 130. In fact, the signal demodulated by the demodulator 614a may include a signal of direct current domain and a high frequency having a frequency ( $2f_m$ ) twice the predetermined frequency ( $f_m$ ), as shown in FIG.7c.

[0088] The output signal from the demodulator 614a may be inputted to the lowpass filter 614b and filtered. A passband of the lowpass filter 614b may be set up as shown in dotted line of FIG.7d. In doing so, only the signal of the direct current domain may pass the lowpass filter 614b to be converted to a digital signal by the A/D converter 616 and inputted to the micro computer 130, and the high frequency having the frequency ( $2f_m$ ) twice the predetermined frequency ( $f_m$ ) may be blocked by the lowpass filter 614b and may not be inputted to the micro computer 130.

[0089] FIG. 8 is a schematic view of a signal to noise ratio relative to a power consumption of a blood pressure monitoring apparatus in another exemplary implementation.

[0090] Now, it can be noted from FIG.8 that the signal-to-noise ratio relative to the power consumption by the optical signal transmitter 602 that outputs an optical signal shows a gentle curve. For example, if the power consumption of the optical signal transmitter 602 is limited to 5mW, the signal-to-noise ratio is approximately 70dB. Furthermore, even if the power consumption of the optical signal transmitter 602 is reduced, the signal-to-noise ratio is not greatly changed but still reaches approximately 70dB. As a result, it can be noted that a precise pulse wave signal can be obtained even if the power consumption is reduced by setting up a low driving power of the optical signal transmitter 602.

[0091] FIG.9 is a schematic block diagram illustrating a construction of still another exemplary implementation of a blood pressure monitoring apparatus, where the apparatus may comprise a micro computer 130 integrally comprised of a pulse wave extractor 614 including a demodulator 614a and a lowpass filter 614b.

[0092] If the demodulator 614a and the lowpass filter 614b are integrally disposed inside the micro computer 130, the micro computer 130 may demodulate the digital signal inputted from the A/D converter 616 by the conventional arithmetic algorithm function. The micro computer 130 may use a finite impulse response (FIR) filter or an infinite impulse response (IIR) filter as the lowpass filter 614b to block the high frequency signal.

[0093] FIG.10 is a schematic block diagram illustrating a construction of still another exemplary implementation of a blood pressure monitoring apparatus, where the apparatus may comprise a micro computer 130 integrally comprised of a tuned amplifier 612, demodulator 614a and a lowpass filter 614.

[0094] As apparent from the foregoing, the blood pressure monitoring apparatus and method according to the instant teaching can monitor an electrocardiogram signal and a pulse wave signal of a subject to calculate a pulse wave propagation time and pulse wave analysis information, and the calculated pulse wave propagation time, pulse wave analysis information and body characteristic information are used to monitor the blood pressure of the subject. The apparatus and method are non-invasive and capable of monitoring the blood pressure without recourse to cuff.

[0095] An optical signal modulated by a particular frequency is emitted to a body of a subject, and the optical signal reflected from the body can be tuned, demodulated and lowpass filtered to remove noise signals generated in the course of monitoring the pulse wave signal, to enhance a signal-to-noise ratio, to reduce the power consumption and to increase

the monitoring accuracy of the blood pressure.

[0096] A tuned amplifier and a pulse wave extractor can be integrally disposed in a micro computer to reduce the size of the blood pressure monitoring apparatus and to enhance the portability of the apparatus.

[0097] Accordingly, exemplary implementations as described herein are illustrative of the general inventive concept, and should not to be construed as limiting thereof. Although the exemplary implementations of the general novel concept have been described, those skilled in the art will readily appreciate that many modifications and variations are possible in the exemplary implementations without materially departing from the scope of the claims.

## Claims

### 1. A blood pressure monitoring apparatus, comprising

- an electrocardiogram monitoring unit (100) adapted to monitor an electrocardiogram signal of a subject;
- a photoplethysmography (PPG) monitoring unit (110) adapted to emit an optical signal of a predetermined frequency to a subject's body, monitor the optical signal that has reflected from or penetrated the subject's body, remove noise and then monitor a pulse wave signal;
- a micro computer (140);
- a display unit (150);

the apparatus being **characterised in that** it further comprises

- a body characteristic information input unit (120) configured to receive a body characteristic information inputted by a user including at least one of sex, weight, height, length of an arm, and age of the subject;
- a temperature sensor adapted to monitor a body temperature of a body part from which the pulse wave signal is monitored; and **in that**
- the micro computer is configured to use the pulse wave signal to calculate a pulse wave analysis information, to calculate a pulse wave propagation time using the pulse wave signal and the electrocardiogram signal and to calculate a blood pressure (P) of the subject using the calculated pulse wave analysis information, the pulse wave propagation time, the body characteristic information inputted by the body characteristic information input unit and the body temperature; and
- the display unit (150) is adapted to display the blood pressure (P) calculated by the micro computer (130).

### 2. The apparatus as claimed in claim 1, wherein the PPG monitoring unit (110) comprises:

- a PPG sensor (112) generating an optical signal of a predetermined frequency and emitting the signal to the body of the subject, receiving the optical signal reflected from the body and converting the signal to an electric signal; and
- a PPG monitoring circuit (114) removing a noise signal and a signal of the predetermined frequency from the electric signal converted by the PPG sensor (112), monitoring a pulse wave signal and inputting the signal to the micro computer (130).

### 3. The apparatus as claimed in claim 2, wherein the PPG sensor (112) comprises:

- an optical transmitter (602) generating an optical signal of a predetermined frequency and emitting the signal to the body of the subject; and
- an optical signal receiver (604) receiving the optical signal reflected from the body and converting the signal to an electric signal.

### 4. The apparatus as claimed in claim 3, further comprising:

- an optical device driving unit (600) driving an optical device of the optical signal transmitter (602) in response to the signal of the predetermined frequency.

### 5. The apparatus as claimed in claim 2, wherein the PPG monitoring circuit (114) comprises:

- a current/voltage converter (610) converting an output current of the PPG sensor (112) to a voltage;
- a tuned amplifier (612) tuning the voltage converted by the current/voltage converter (610) by a frequency scope

that includes a band of a predetermined frequency to remove the noise signal; and  
 a pulse wave extractor (614) mixing the output signal of the tuned amplifier (612) with the signal of the predetermined frequency and lowpass filtering to extract a pulse wave signal and to output the pulse wave signal to the micro computer (130).

5  
 6. The apparatus as claimed in claim 5, wherein the pulse wave extractor (614) comprises:

10  
 a demodulator (614a) multiplying the output signal from the tuned amplifier (612) by the signal of the predetermined frequency; and  
 a lowpass filter (614b) lowpass-filtering the output signal of the demodulator (614a) to extract a pulse wave signal.

15  
 7. The apparatus as claimed in claim 5, wherein the pulse wave extractor (614) is integrally disposed in the micro computer (130), or the tuned amplifier (612) and the pulse wave extractor (614) are integrally disposed in the micro computer (130).

20  
 8. The apparatus as claimed in claim 1,  
 wherein the apparatus is adapted to calculate the blood pressure (P) by plugging the pulse wave propagation time, the pulse wave analysis information, the body characteristic information and the body temperature in the following regression equation:

25  

$$\text{Blood pressure (P)} = k_1 * \text{pulse wave propagation time} + \sum_i k_{2i} * \text{pulse wave analysis information} + \sum_j k_{3j} * \text{body characteristic information} + k_4 * \text{body temperature.}$$

30  
 where k1, k2i, k3j and k4 define coefficient values corresponding respectively to the pulse wave propagation time, the pulse wave analysis information, the body characteristic information and the body temperature monitored from the regression analysis, which are predetermined values that are experimentally obtained.

35  
 9. The apparatus as claimed in claim 1, further comprising: storage (140) for storing and managing the monitored blood pressure under the control of the micro computer (130) and/or for storing the body characteristic information of the subject, wherein if the body characteristic information unit (120) selects a subject stored in the storage (140), the body characteristic information of the selected subject is read out from the storage (140) and inputted.

40  
 10. Blood pressure monitoring apparatus as claimed in one of the claims 1-9, which is integrated into one of a personal digital assistant (PDA), a portable multimedia player (PMP), a mobile communication terminal or an MP3 player.

45  
 11. Mobile terminal including a blood pressure monitoring apparatus as claimed in one of the claims 1-9, wherein the electrocardiogram monitoring electrodes (102a, 102b, 102c) are disposed at left and right lateral surfaces of a body of the mobile terminal and at an external lower surface of the mobile terminal, wherein the PPG sensor (112) is disposed at an adjacent location of one electrocardiogram monitoring electrode (102c) disposed at the external lower surface.

50  
 12. Mobile terminal including a blood pressure monitoring apparatus as claimed in one of the claims 1-9, wherein the electrocardiogram monitoring electrodes (102a, 102b) are disposed at on one lateral surface of the body of the mobile terminal and a further electrocardiogram monitoring electrode (102c) and the PPG sensor (112) are disposed at the other lateral surface of the body of the mobile terminal.

55  
 13. A blood pressure monitoring method **characterized by the steps of:**

- inputting (S200) by a user body characteristic information of a subject including at least one of sex, weight, height, length of an arm, and age of the subject via a body characteristic information input unit (120);

- monitoring an electrocardiogram signal of the subject;
- emitting an optical signal of a predetermined frequency to the subject's body,
- receiving the optical signal that has reflected from or penetrated the subject's body to remove noise and to then monitor a pulse wave signal;
- monitoring a body temperature of a body part from which the pulse wave signal is monitored;
- calculating (S204, S206) a pulse wave propagation time and a pulse wave analysis information using the monitored electrocardiogram signal and pulse wave signal; and
- monitoring the blood pressure (P) of the subject by the calculated pulse wave propagation time, pulse wave analysis information, the body temperature and body characteristic information.

14. The method as claimed in claim 13, wherein the step of monitoring the pulse wave signal comprises: generating an optical signal of a predetermined frequency and emitting the signal to the body of the subject; receiving the optical signal that has penetrated or has been reflected from the body of the subject and converting the signal to an electric signal; tuning the electric signal to a frequency band including the predetermined frequency to remove the noise signal; and mixing the electric signal removed of the noise signal to the predetermined frequency and filtering to remove the high frequency and to monitor a pulse wave signal.

## Patentansprüche

1. Blutdruck-Überwachungsvorrichtung, umfassend:

- eine Elektrokardiogramm-Überwachungseinheit (100), die dazu geeignet ist, ein Elektrokardiogrammsignal einer Testperson zu überwachen;
- eine Photoplethysmographie (PPG)-Überwachungseinheit (110), die dazu geeignet ist, ein optisches Signal von einer vorgegebenen Frequenz zu einem Körper der Testperson auszusenden, das optische Signal zu überwachen, das vom Körper der Testperson reflektiert worden ist oder denselben durchdrungen hat, um Rauschen zu entfernen, und dann ein Pulswellensignal zu überwachen;
- einen Mikrocomputer (140);
- eine Anzeigeeinheit (150);

wobei die Vorrichtung **dadurch gekennzeichnet ist, dass** sie ferner umfasst:

- eine Einheit zur Eingabe von Körpereigenschaftsinformation (120), die dazu eingerichtet ist, eine von einem Benutzer eingegebene Körpereigenschaftsinformation einschließlich von mindestens einem von Geschlecht, Gewicht, Größe, Armlänge und Alter der Testperson zu empfangen;
- einen Temperatursensor, der dazu geeignet ist, eine Körpertemperatur eines Körperteils zu überwachen, von dem das Pulswellensignal überwacht wird; und wobei die Vorrichtung ferner **dadurch gekennzeichnet ist, dass**
- der Mikrocomputer dazu ausgerichtet ist, das Pulswellensignal zu verwenden, um eine Pulswellen-Analyseinformation zu berechnen, um eine Pulswellenlaufzeit mittels des Pulswellensignals und des Elektrokardiogrammsignals zu berechnen und um einen Blutdruck (P) der Testperson mittels der berechneten Pulswellen-Analyseinformation, der Pulswellenlaufzeit, der durch die Einheit zur Eingabe von Körpereigenschaftsinformation eingegebenen Körpereigenschaftsinformation und der Körpertemperatur zu berechnen; und
- die Anzeigeeinheit (150) dazu geeignet ist, den vom Mikrocomputer (130) berechneten Blutdruck (P) anzuzeigen.

2. Vorrichtung nach Anspruch 1, wobei die PPG-Überwachungseinheit (110) umfasst:

- einen PPG-Sensor (112), der ein optisches Signal einer vorgegebenen Frequenz erzeugt und das Signal zum Körper der Testperson aussendet, das vom Körper reflektierte optische Signal empfängt und das Signal in ein elektrisches Signal umwandelt; und
- einen PPG-Überwachungsschaltkreis (114), der ein Rauschsignal und ein Signal der vorgegebenen Frequenz von dem vom PPG-Sensor (112) umgewandelten elektrischen Signal entfernt, ein Pulswellensignal überwacht und das Signal dem Mikrocomputer (130) eingibt.

3. Vorrichtung nach Anspruch 2, wobei der PPG-Sensor (112) umfasst:

- einen optischen Sender (602), der ein optisches Signal einer vorgegebenen Frequenz erzeugt und das Signal

zum Körper der Testperson aussendet; und

- einen Empfänger für ein optisches Signal (604), der das vom Körper reflektierte optische Signal empfängt und das Signal in ein elektrisches Signal umwandelt.

5 4. Vorrichtung nach Anspruch 3, ferner umfassend:

- eine Treibereinheit (600) für eine optische Vorrichtung, die eine optische Vorrichtung des Senders für ein optisches Signal (602) in Antwort auf das Signal der vorgegebenen Frequenz ansteuert.

10 5. Vorrichtung nach Anspruch 2, wobei der PPG-Überwachungsschaltkreis (114) umfasst:

- einen Strom-/Spannungswandler (610), der einen Ausgabestrom des PPG-Sensors (112) in eine Spannung umwandelt;

15 - einen abgestimmten Verstärker (612), der die vom Strom-/Spannungswandler (610) gewandelte Spannung auf einen Frequenzbereich abstimmt, der ein Band einer vorgegebenen Frequenz enthält, um das Rauschsignal zu entfernen; und

- einen Pulswellenextraktor (614), der das Ausgabesignal des abgestimmten Verstärkers (612) mit dem Signal der vorgegebenen Frequenz mischt und einen Tiefpassfilter anwendet, um ein Pulswellensignal zu extrahieren und das Pulswellensignal dem Mikrocomputer (130) auszugeben.

20

6. Vorrichtung nach Anspruch 5, wobei der Pulswellenextraktor (614) umfasst:

- einen Demodulator (614a), der das Ausgabesignal vom abgestimmten Verstärker (612) mit dem Signal der vorgegebenen Frequenz multipliziert; und

25 - einen Tiefpassfilter (614b), der auf das Ausgabesignal des Demodulators (614a) einen Tiefpassfilter anwendet, um ein Pulswellensignal zu extrahieren.

7. Vorrichtung nach Anspruch 5, wobei der Pulswellenextraktor (614) fest eingebaut im Mikrocomputer (130) angeordnet ist, oder wobei der abgestimmte Verstärker (612) und der Pulswellenextraktor (614) fest eingebaut im Mikrocomputer (130) angeordnet sind.

30

8. Vorrichtung nach Anspruch 1, wobei die Vorrichtung dazu geeignet ist, den Blutdruck (P) durch Einsetzen der Pulswellenlaufzeit, der Pulswellen-Analyseinformation, der Körpereigenschaftsinformation und der Körpertemperatur in die folgende Regressionsgleichung zu berechnen:

35

$$\text{Blutdruck (P)} = k_1 * \text{Pulswellenlaufzeit} + \sum_i k_{2i} * \text{Pulswellen-Analyseinformation} +$$

$$40 \sum_j k_{3j} * \text{Körpereigenschaftsinformation} + k_4 * \text{Körpertemperatur};$$

45 wobei  $k_1$ ,  $k_{2i}$ ,  $k_{3j}$  und  $k_4$  aus der Regressionsanalyse beobachtete Koeffizientenwerte jeweils entsprechend der Pulswellenlaufzeit, der Pulswellen-Analyseinformation, der Körpereigenschaftsinformation und der Körpertemperatur definieren, die vorgegebene experimentell erhaltene Werte sind.

50 9. Vorrichtung nach Anspruch 1, ferner umfassend:

- Speicher (140) zum Speichern und Verwalten des überwachten Blutdrucks unter der Steuerung des Mikrocomputers (130) und/oder zum Speichern der Körpereigenschaftsinformation der Testperson, wobei wenn die Einheit zur Eingabe von Körpereigenschaftsinformation (120) eine im Speicher (140) gespeicherte Testperson auswählt, die Körpereigenschaftsinformation der ausgewählten Testperson aus dem Speicher (140) ausgelesen und eingegeben wird.

55

10. Blutdruck-Überwachungsvorrichtung nach einem der Ansprüche 1 bis 9, die in einem von einem Minicomputer (PDA), einem tragbaren Multimedia-Player (PMP), einem mobilen Kommunikationsendgerät oder einem MP3-Player

integriert ist.

5 11. Mobiles Endgerät, das eine Blutdruck-Überwachungsrichtung nach einem der Ansprüche 1 bis 9 enthält, wobei die Elektrokardiogramm-Überwachungselektroden (102a, 102b, 102c) an linken und rechten seitlichen Oberflächen eines Gehäuses des mobilen Endgeräts und an einer äußeren unteren Oberfläche des mobilen Endgeräts angeordnet sind, wobei der PPG-Sensor (112) an einer benachbarten Stelle von einer an der äußeren unteren Oberfläche angeordneten Elektrokardiogramm-Überwachungselektrode (102c) angeordnet ist.

10 12. Mobiles Endgerät, das eine Blutdrucküberwachungsrichtung nach einem der Ansprüche 1 bis 9 enthält, wobei die Elektrokardiogramm-Überwachungselektroden (102a, 102b) an einer seitlichen Oberfläche des Gehäuses des mobilen Endgeräts angeordnet sind und eine weitere Elektrokardiogramm-Überwachungselektrode (102c) und der PPG-Sensor (112) an der anderen seitlichen Oberfläche des Gehäuses des mobilen Endgeräts angeordnet sind.

15 13. Verfahren zur Blutdruck-Überwachung, **gekennzeichnet durch** folgende Schritte:

- Eingeben (S200) von Körpereigenschaftsinformation einer Testperson über eine Einheit zur Eingabe von Körpereigenschaftsinformation (120) **durch** einen Benutzer einschließlich von mindestens einem von Geschlecht, Gewicht, Größe, Armlänge und Alter der Testperson;
- Überwachen eines Elektrokardiogrammsignals der Testperson;
- 20 - Aussenden eines optischen Signals von einer vorgegebenen Frequenz zum Körper der Testperson;
- Empfangen des optischen Signals, das vom Körper der Testperson reflektiert worden ist oder denselben durchdrungen hat, um Rauschen zu entfernen und um dann ein Pulswellensignal zu überwachen;
- Überwachen einer Körpertemperatur eines Körperteils, von dem das Pulswellensignal überwacht wird;
- 25 - Berechnen (S204, S206) einer Pulswellenlaufzeit und einer Pulswellen-Analyseinformation mittels des überwachten Elektrokardiogrammsignals und des Pulswellensignals; und
- Überwachen des Blutdrucks (P) der Testperson **durch** die berechnete Pulswellenlaufzeit, die Pulswellen-Analyseinformation, die Körpertemperatur und die Körpereigenschaftsinformation.

30 14. Verfahren nach Anspruch 13, wobei der Schritt des Überwachens des Pulswellensignals umfasst:

- Erzeugen eines optischen Signals einer vorgegebenen Frequenz und Aussenden des Signals zum Körper der Testperson;
- Empfangen des optischen Signals, das den Körper der Testperson durchdrungen hat oder von demselben reflektiert worden ist und Umwandeln des Signals in ein elektrisches Signal;
- 35 - Abstimmen des elektrischen Signals auf ein Frequenzband einschließlich der vorgegebenen Frequenz, um das Rauschsignal zu entfernen; und
- Mischen des elektrischen Signals, das vom Rauschsignal entfernt worden ist, mit der vorgegebenen Frequenz und Filtern, um die hohe Frequenz zu entfernen und ein Pulswellensignal zu überwachen.

40 **Revendications**

45 1. Dispositif de contrôle de pression sanguine, comprenant une unité de contrôle d'électrocardiogramme (100) adaptée pour contrôler un signal d'électrocardiogramme d'un sujet ;  
 une unité de contrôle de photopléthysmographie (PPG) (110) adaptée pour émettre un signal optique d'une fréquence prédéterminée vers le corps d'un sujet, contrôler le signal optique qui a été réfléchi par ou a pénétré dans le corps du sujet, afin d'enlever le bruit et d'ensuite contrôler un signal d'onde de pression ;  
 un micro-ordinateur (140) ;  
 50 une unité d'affichage (150) ;  
 une unité d'entrée d'information caractéristique corporelle (120) configurée pour recevoir une information caractéristique corporelle entrée par un utilisateur incluant au moins l'une parmi le sexe, le poids, la taille, la longueur d'un bras, et l'âge du sujet ;  
 un capteur de température adapté pour contrôler une température corporelle d'une partie corporelle à partir de laquelle un signal d'onde de pression est contrôlé ; et en ce que  
 55 le microordinateur est configuré pour utiliser le signal d'onde de pression pour calculer une information d'analyse d'onde de pression, pour calculer un temps de propagation d'onde de pression en utilisant le signal d'onde de pression et le signal d'électrocardiogramme et pour calculer une pression sanguine (P) du sujet en utilisant l'in-

## EP 1 977 688 B1

formation d'analyse d'onde de pression, le temps de propagation d'onde de pression, l'information de caractéristique corporelle entrée par l'unité d'entrée d'information caractéristique corporelle et la température corporelle ; et l'unité d'affichage (150) est adaptée pour afficher la pression sanguine (P) calculée par le microordinateur (130).

5 2. Dispositif selon la revendication 1, dans lequel l'unité de contrôle de PPG (110) comprend :

un capteur de PPG (112) générant un signal optique d'une fréquence prédéterminée et émettant le signal vers le corps du sujet, recevant le signal optique réfléchi par le corps et convertissant le signal en un signal électrique ; et

10 un circuit de contrôle de PPG (114) enlevant un signal de bruit et un signal de la fréquence prédéterminée du signal électrique converti par le capteur de PPG (112), contrôlant un signal d'onde de pression et entrant le signal dans le microordinateur (130).

15 3. Dispositif selon la revendication 2, dans lequel le capteur de PPG (112) comprend :

un émetteur optique (602) générant un signal optique d'une fréquence prédéterminée et émettant le signal vers le corps du sujet ; et

20 un récepteur de signal optique (604) recevant le signal optique réfléchi par le corps et convertissant le signal en un signal électrique.

25 4. Dispositif selon la revendication 3, comprenant en outre :  
une unité de pilotage de dispositif optique (600) pilotant un dispositif optique de l'émetteur de signal optique (602) en réponse au signal de la fréquence prédéterminée.

30 5. Dispositif selon la revendication 2, dans lequel le circuit de contrôle de PPG (114) comprend :

un convertisseur courant/tension (610) convertissant un courant de sortie du capteur de PPG (112) en une tension ;

35 un amplificateur syntonisé (612) syntonisant la tension convertie par le convertisseur courant/tension (610) par un domaine de fréquence qui inclut une bande d'une fréquence prédéterminée pour enlever le signal de bruit ; et un extracteur d'onde de pression (614) mélangeant le signal de sortie de l'amplificateur syntonisé (612) avec le signal de la fréquence prédéterminée et filtrant passe-bas pour extraire un signal d'onde de pression et pour sortir le signal d'onde de pression vers le microordinateur (130).

40 6. Dispositif selon la revendication 5, dans lequel l'extracteur d'onde de pression (614) comprend :

un démodulateur (614a) multipliant le signal de sortie de l'amplificateur syntonisé (612) par le signal de la fréquence prédéterminée ; et

45 un filtre passe-bas (614b) filtrant passe-bas le signal de sortie du démodulateur (614a) pour extraire un signal d'onde de pression.

50 7. Dispositif selon la revendication 5, dans lequel l'extracteur d'onde de pression (614) est disposé intégralement dans le microordinateur (130), ou l'amplificateur syntonisé (612) et l'extracteur d'onde de pression (614) sont disposés intégralement dans le microordinateur (130).

55 8. Dispositif selon la revendication 1, dans lequel le dispositif est adapté pour calculer la pression sanguine (P) en combinant le temps de propagation d'onde de pression, l'information d'analyse d'onde de pression, l'information de caractéristique corporelle et la température corporelle dans l'équation de régression suivante :

$$\text{pression sanguine (P)} = k_1 * \text{temps de propagation d'onde de pression} + \sum_i k_{2i} * \text{information d'analyse d'onde de pression} + \sum_j k_{3j} * \text{information de caractéristique corporelle} + k_4 * \text{température corporelle},$$

où  $k_1$ ,  $k_{2i}$ ,  $k_{3j}$  et  $k_4$  définissent des valeurs de coefficient correspondant respectivement au temps de propagation d'onde de pression, à l'information d'analyse d'onde de pression, à l'information de caractéristique corporelle

et à la température corporelle contrôlés par l'analyse par régression, qui sont des valeurs prédéterminées qui sont obtenues expérimentalement.

9. Dispositif selon la revendication 1, comprenant en outre :

une mémoire (140) pour stocker et gérer la pression sanguine contrôlée sous le contrôle du microordinateur (130) et/ou pour stocker l'information de caractéristique corporelle du sujet, dans lequel si l'unité d'information de caractéristique corporelle (120) sélectionne un sujet stocké dans la mémoire (140); l'information de caractéristique corporelle du sujet sélectionné est lue dans la mémoire (140) et entrée.

10. Dispositif de contrôle de pression sanguine selon l'une quelconque des revendications 1-9, qui est intégré dans l'un d'un assistant personnel numérique (PDA), un lecteur multimédia portable (PMP), un terminal de communication mobile ou un lecteur MP3.

11. Terminal mobile incluant un dispositif de contrôle de pression sanguine selon l'une quelconque des revendications 1-9, dans lequel les électrodes de contrôle d'électrocardiogramme (102a, 102b, 102c) sont disposées au niveau de surfaces latérales gauche et droite d'un corps du terminal mobile et d'une surface inférieure extérieure du terminal mobile, dans lequel le capteur de PPG (112) est disposé en un emplacement adjacent à une électrode de contrôle d'électrocardiogramme (102c) disposée au niveau d'une surface inférieure extérieure.

12. Terminal mobile incluant un dispositif de contrôle de pression sanguine selon l'une quelconque des revendications 1-9, dans lequel les électrodes de contrôle d'électrocardiogramme (102a, 102b) sont disposées au niveau d'une surface latérale du corps du terminal mobile et une autre électrode de contrôle d'électrocardiogramme (102c) et le capteur de PPG (112) sont disposés au niveau de l'autre surface latérale du corps du terminal mobile.

13. Procédé de contrôle de pression sanguine **caractérisé par** les étapes consistant à :

entrer (S200) par un utilisateur une information de caractéristique corporelle d'un sujet incluant au moins l'une parmi le sexe, le poids, la taille, la longueur d'un bras, et l'âge du sujet via une unité d'entrée d'information caractéristique corporelle (120) ;

contrôler un signal d'électrocardiogramme du sujet ;

émettre un signal optique d'une fréquence prédéterminée vers le corps du sujet,

recevoir le signal optique qui a été réfléchi par ou a pénétré dans le corps du sujet pour enlever le bruit et ensuite contrôler un signal d'onde de pression ;

contrôler une température corporelle d'une partie corporelle à partir de laquelle le signal d'onde de pression est contrôlé ;

calculer (S204, S206) un temps de propagation d'onde de pression et une information d'analyse d'onde de pression en utilisant le signal d'électrocardiogramme contrôlé et le signal d'onde de pression ; et

contrôler la pression sanguine (P) du sujet par le temps de propagation d'onde de pression, l'information d'analyse d'onde de pression, la température corporelle et l'information de caractéristique corporelle.

14. Procédé selon la revendication 13, dans lequel l'étape consistant à contrôler le signal d'onde de pression comprend de :

générer un signal optique d'une fréquence prédéterminée et émettre le signal vers le corps du sujet ; recevoir le signal optique qui a pénétré ou a été réfléchi par le corps du sujet et convertir le signal en un signal électrique ; syntoniser le signal électrique à un bande de fréquence incluant la fréquence prédéterminée pour enlever le signal de bruit ; et

mélanger le signal électrique sans le signal de bruit à la fréquence prédéterminée et filtrer pour enlever la haute fréquence et pour contrôler un signal d'onde de pression.

FIG. 1

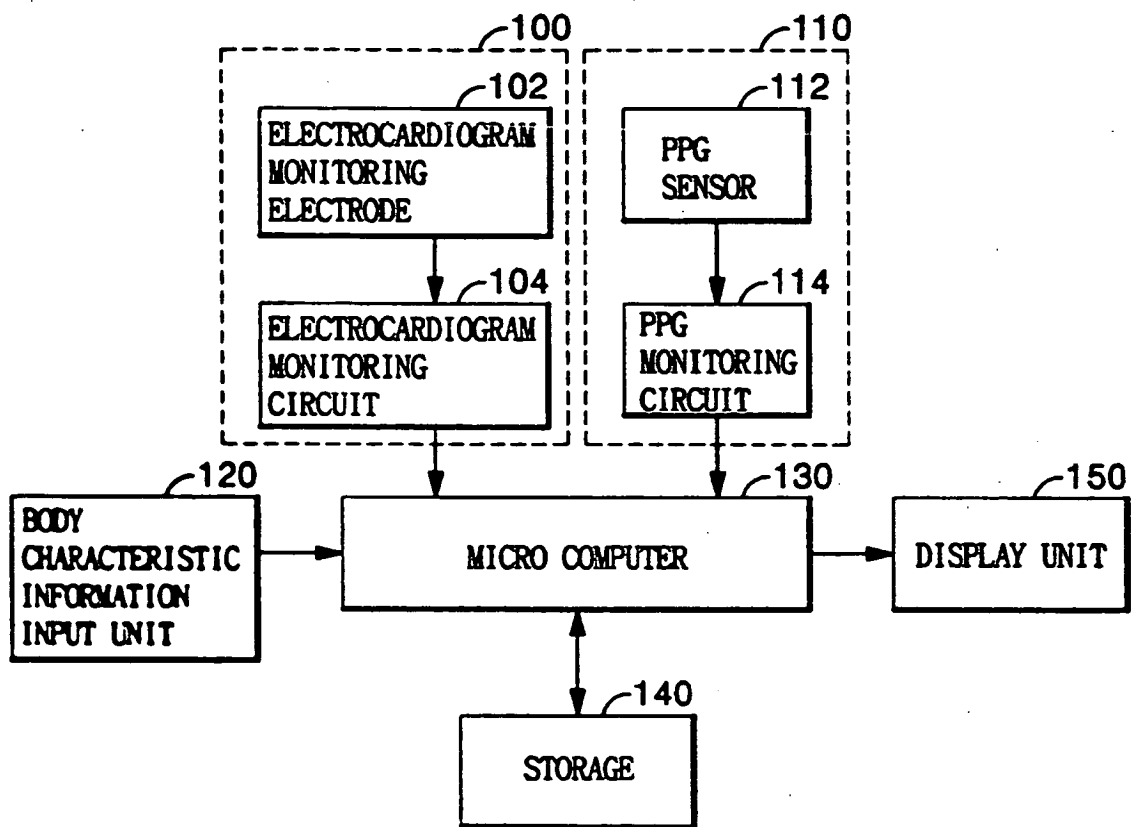
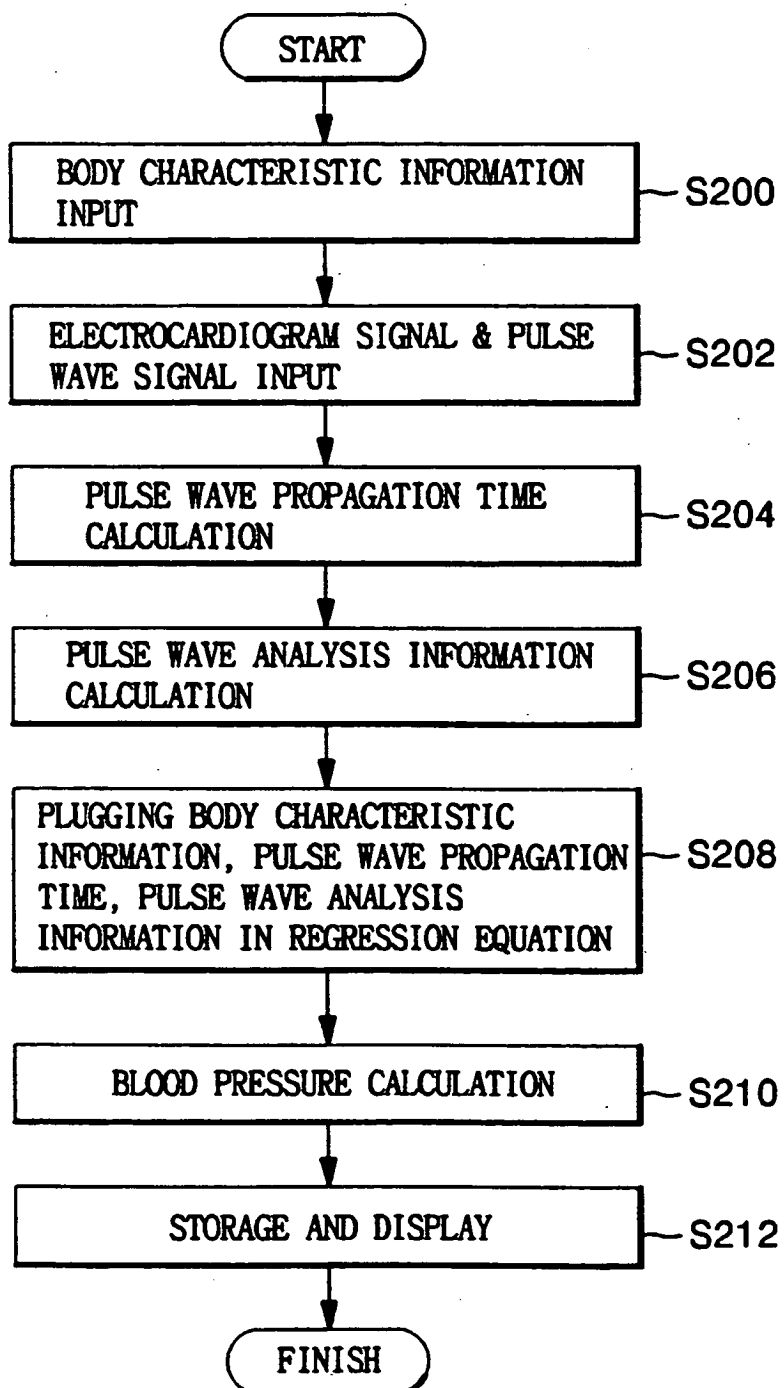
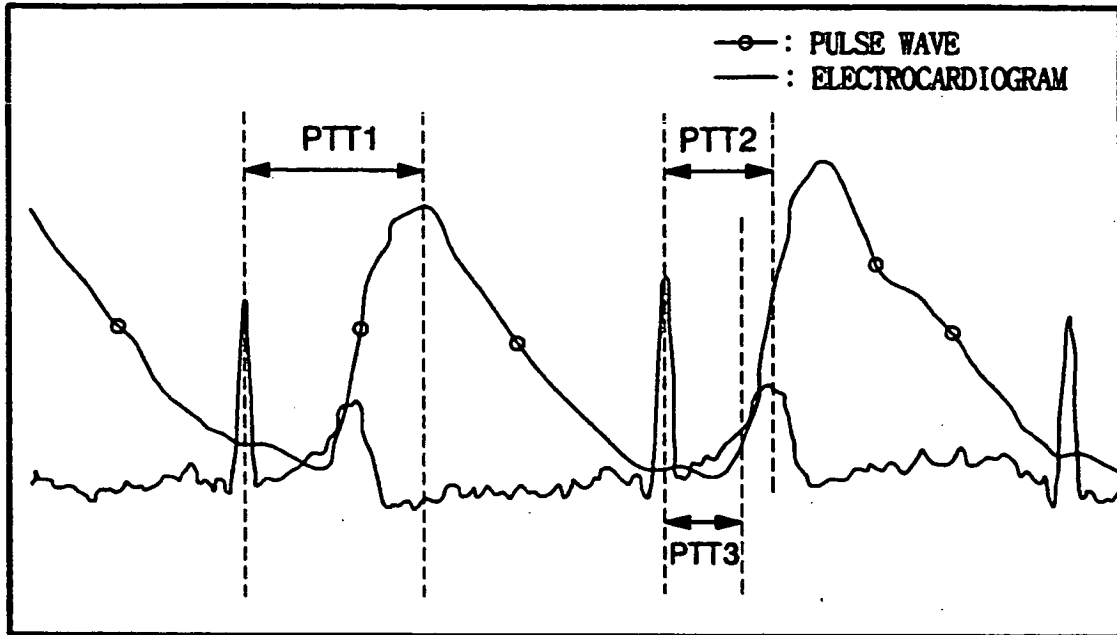

FIG. 2



**FIG. 3**



**FIG. 4A**

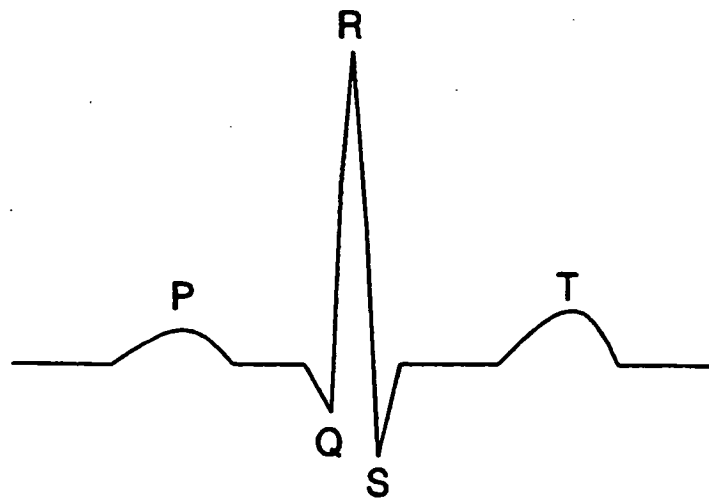

**FIG. 4B**

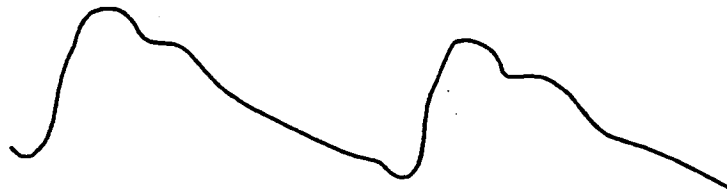

**FIG. 4C**

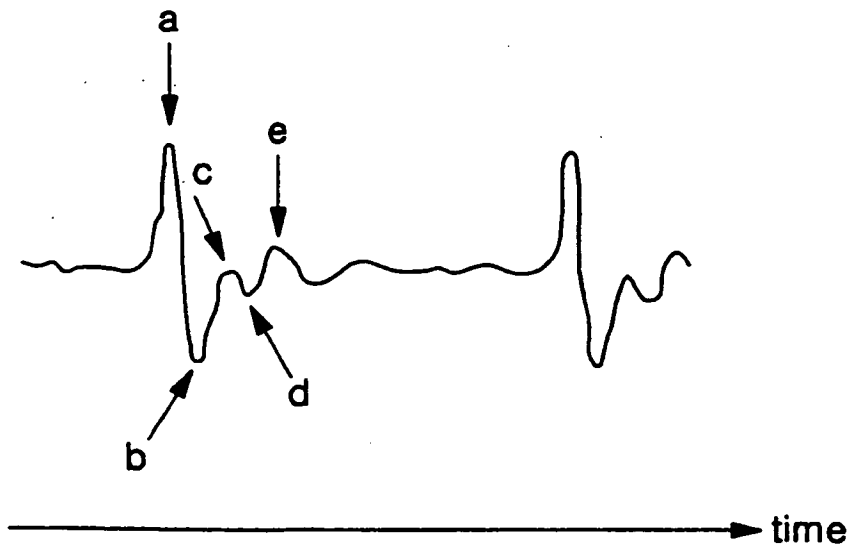

**FIG. 5**

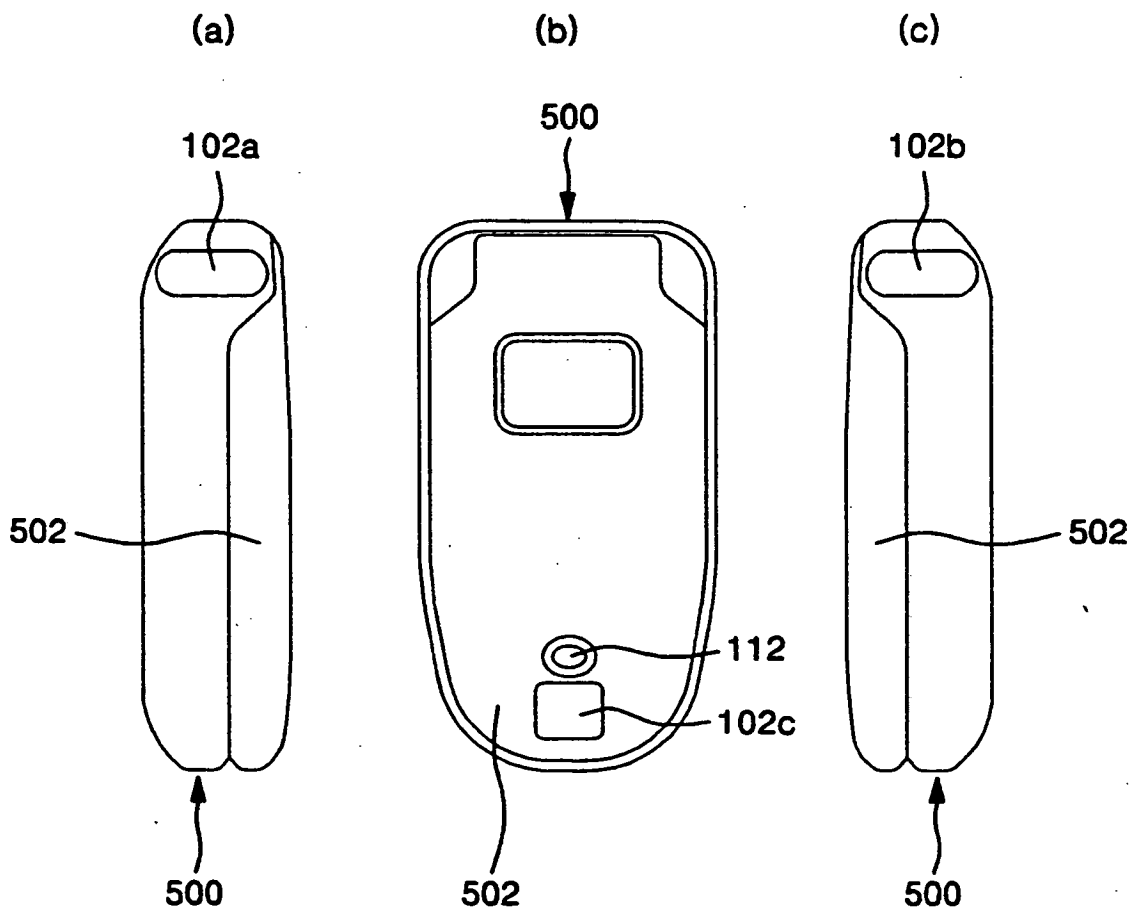

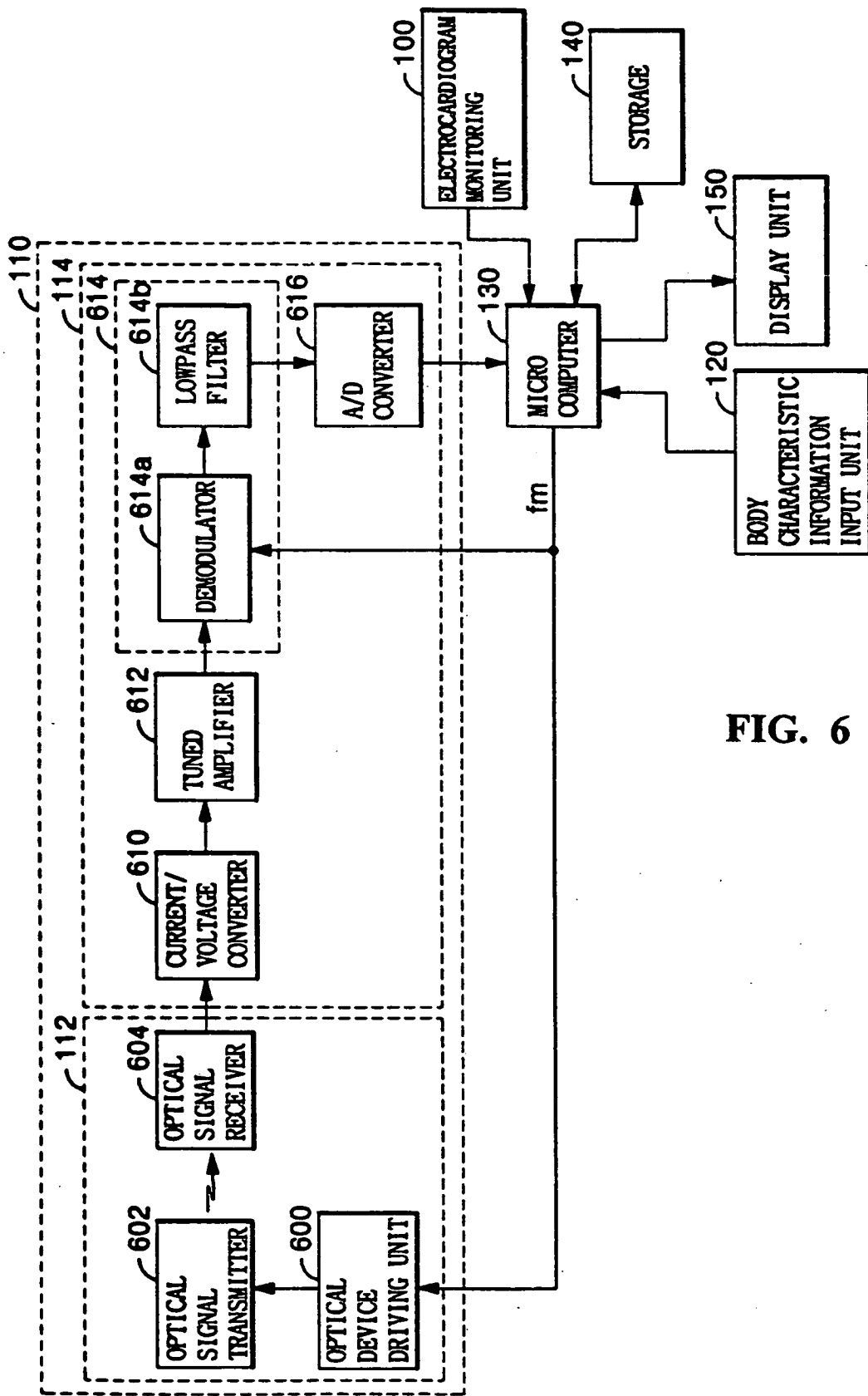

FIG. 6

FIG. 7A

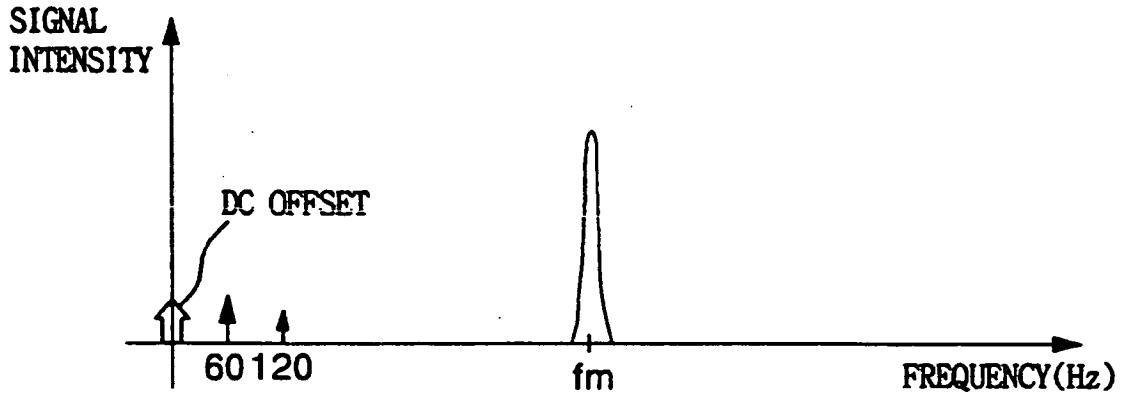

FIG. 7B

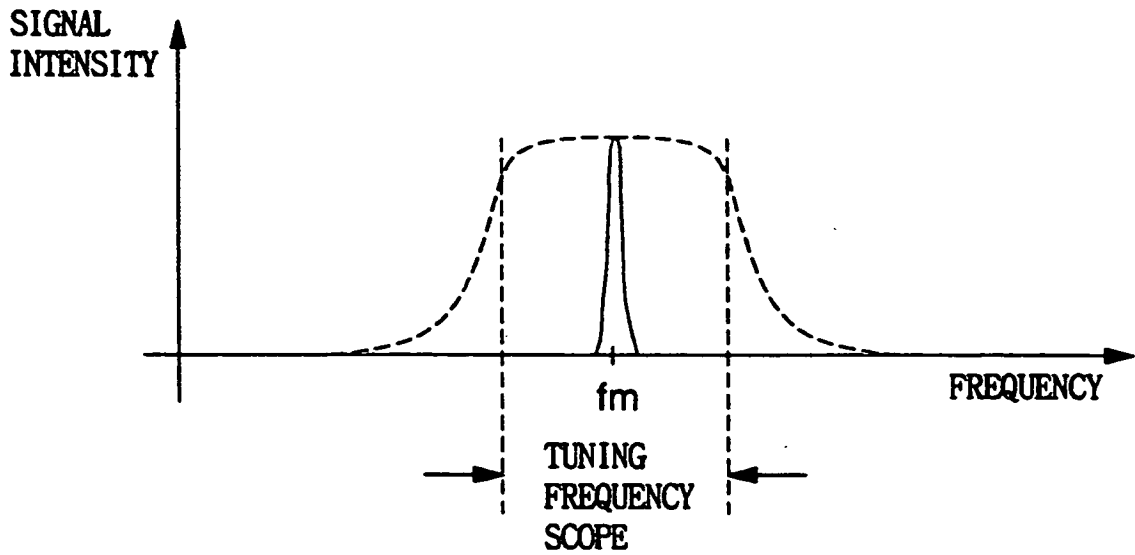

FIG. 7C

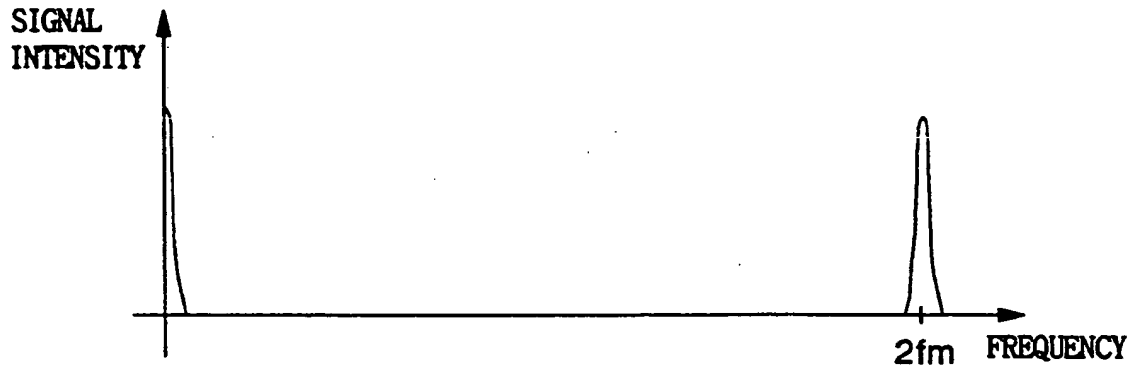

FIG. 7D

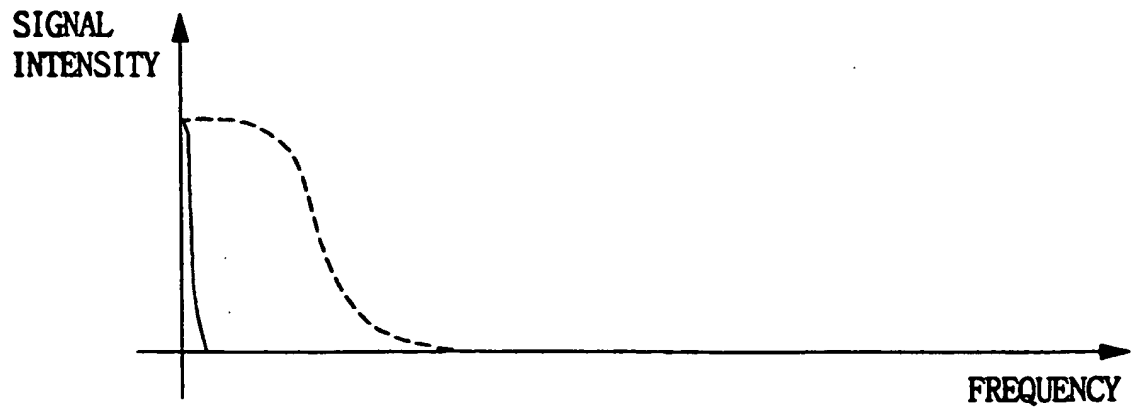
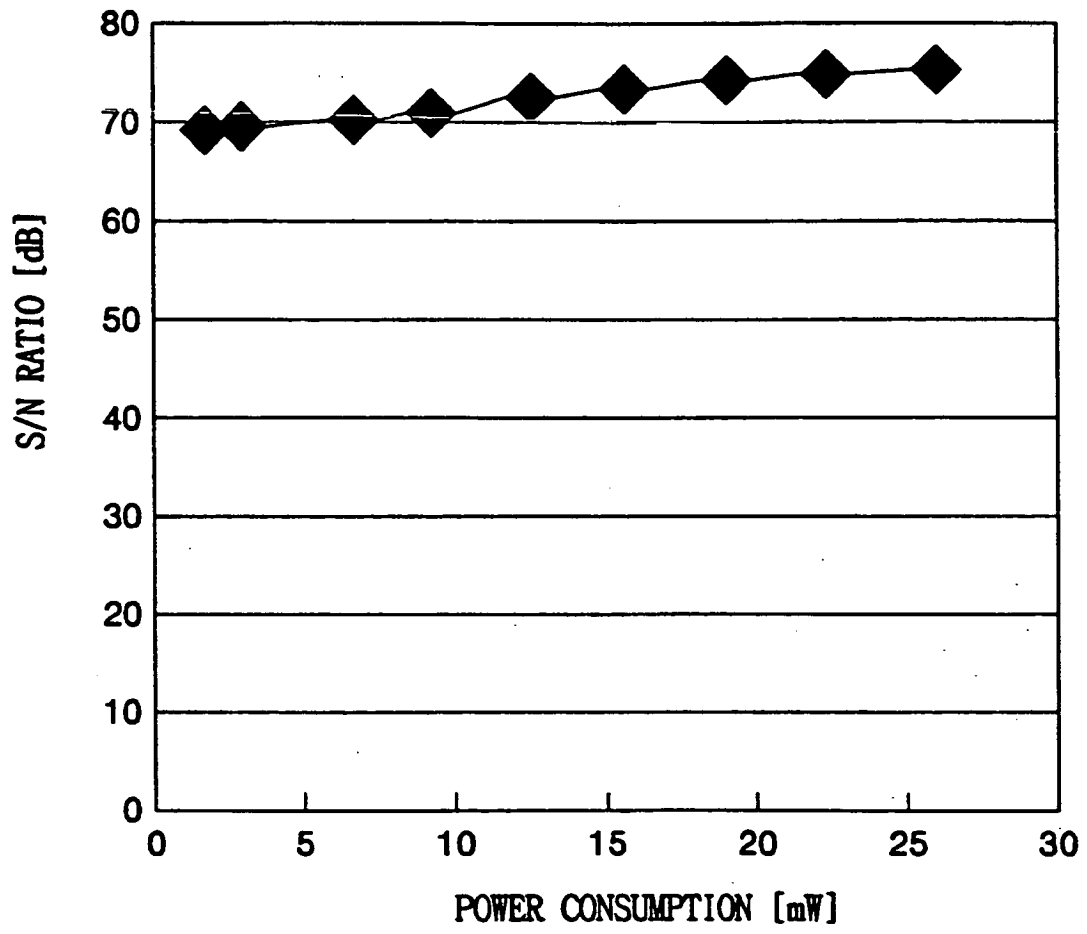

FIG. 8



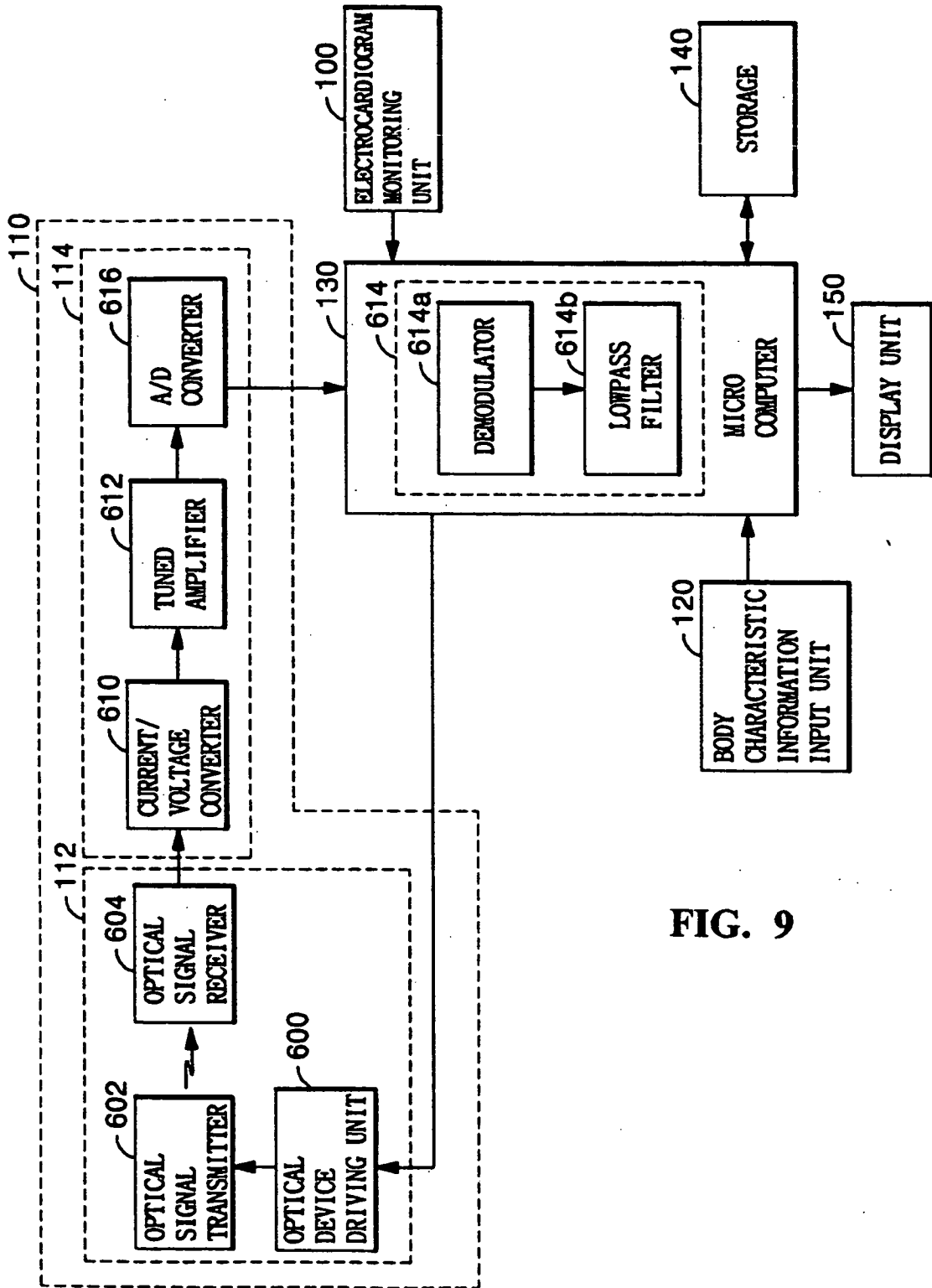
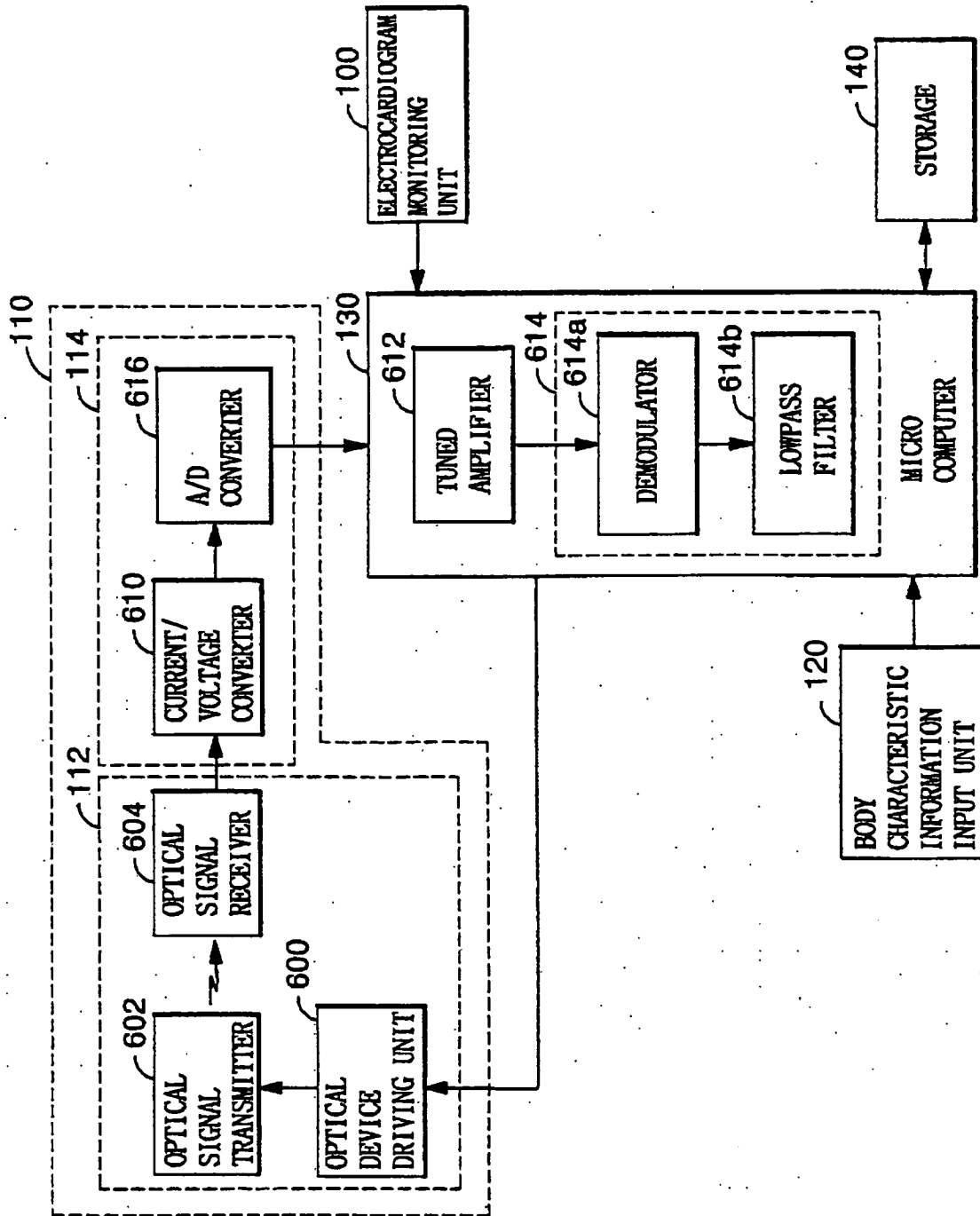

FIG. 9

FIG. 10



**REFERENCES CITED IN THE DESCRIPTION**

*This list of references cited by the applicant is for the reader's convenience only. It does not form part of the European patent document. Even though great care has been taken in compiling the references, errors or omissions cannot be excluded and the EPO disclaims all liability in this regard.*

**Patent documents cited in the description**

- KR 1020070033411 [0001]
- US 200201936 A1 [0007]

专利名称(译)	血压监测装置和方法		
公开(公告)号	<a href="#">EP1977688B1</a>	公开(公告)日	2010-07-14
申请号	EP2008006815	申请日	2008-04-03
申请(专利权)人(译)	LG电子株式会社.		
当前申请(专利权)人(译)	LG电子株式会社.		
[标]发明人	OH HYUN HO SHIM BONG CHU LEE YOUN JAE LEE KWY RO CHO SEONG MOON HONG HYUNG KI		
发明人	OH, HYUN HO SHIM, BONG CHU LEE, YOUN JAE LEE, KWY RO CHO, SEONG MOON HONG, HYUNG KI		
IPC分类号	A61B5/00		
CPC分类号	A61B5/02416 A61B5/021 A61B5/02125 A61B5/0245 A61B5/0456 A61B5/6826 A61B5/6838 A61B5/7239		
优先权	1020070033411 2007-04-04 KR		
其他公开文献	EP1977688A2 EP1977688A3		
外部链接	<a href="#">Espacenet</a>		

摘要(译)

公开了一种血压监测装置和方法，其能够使用心电图信号，脉搏波信号和对象的身体特征信息来监测对象的血压，其中监测对象的心电图信号和脉搏波信号。去除由监测脉搏波信号产生的噪声信号，允许监测受试者的精确血压，并使用监测的脉搏波信号计算脉搏波分析信息，并使用心电图信号和脉搏波信号计算脉冲传播时间（PPT），并将计算出的脉搏波传播时间，脉搏波分析信息和对象的身体特征信息插入预定的回归方程中以监测血压。

**[Equation 1]**

$$c = \sqrt{\frac{V}{\delta(\partial V / \partial P)}} = \sqrt{\frac{V}{\delta} \frac{\partial P}{\partial V}}$$