

(19)



(11)

**EP 1 885 235 B1**

(12)

**EUROPEAN PATENT SPECIFICATION**

(45) Date of publication and mention of the grant of the patent:  
**18.12.2013 Bulletin 2013/51**

(51) Int Cl.:  
**A61B 5/00** (2006.01) **G01N 21/25** (2006.01)  
**A61B 5/1455** (2006.01) **A61B 5/1495** (2006.01)

(21) Application number: **06770173.0**

(86) International application number:  
**PCT/US2006/018082**

(22) Date of filing: **10.05.2006**

(87) International publication number:  
**WO 2006/124455 (23.11.2006 Gazette 2006/47)**

**(54) IMPROVED METHOD FOR SPECTROPHOTOMETRIC BLOOD OXYGENATION MONITORING**

VERBESSERTES VERFAHREN FÜR DIE SPEKTROPHOTOMETRISCHE ÜBERWACHUNG DER BLUTOXYGENIERUNG

PROCEDE AMELIORE POUR CONTROLER L'OXYGENATION DU SANG PAR SPECTROPHOTOMETRIE

(84) Designated Contracting States:  
**AT BE BG CH CY CZ DE DK EE ES FI FR GB GR HU IE IS IT LI LT LU LV MC NL PL PT RO SE SI SK TR**

(72) Inventor: **BENNI, Paul, B.**  
**Guilford, CT 06437 (US)**

(30) Priority: **12.05.2005 US 680192 P**

(74) Representative: **Ramsay, Laura Anne Dehns**  
**St Bride's House**  
**10 Salisbury Square**  
**London EC4Y 8JD (GB)**

(43) Date of publication of application:  
**13.02.2008 Bulletin 2008/07**

(73) Proprietor: **CAS MEDICAL SYSTEMS, INC.**  
**Branford, CT 06450 (US)**

(56) References cited:  
**WO-A2-01/84107 WO-A2-2004/010844**  
**US-A- 5 772 589 US-B2- 6 456 862**

**EP 1 885 235 B1**

Note: Within nine months of the publication of the mention of the grant of the European patent in the European Patent Bulletin, any person may give notice to the European Patent Office of opposition to that patent, in accordance with the Implementing Regulations. Notice of opposition shall not be deemed to have been filed until the opposition fee has been paid. (Art. 99(1) European Patent Convention).

**Description**

## BACKGROUND OF THE INVENTION

## 5 1. Technical Field.

[0001] This invention relates to methods for non-invasively determining biological tissue oxygenation in general, and to non-invasive methods utilizing near-infrared spectroscopy (NIRS) techniques for determining the same in particular.

## 10 2. Background Information.

[0002] U.S. Patent No. 6,456,862 and WO 2004/010844 both assigned to the assignee of the present application, disclose methods for spectrophotometric blood oxygenation monitoring. Oxygen saturation within blood is defined as:

15

$$O_2\text{saturation}\% = \frac{HbO_2}{(HbO_2 + Hb)} * 100\% \quad (\text{Eqn. 1})$$

20 These methods, and others known within the prior art, utilize variants of the Beer-Lambert law to account for optical attenuation in tissue at a particular wavelength. Relative concentrations of oxyhemoglobin ( $HbO_2$ ) and deoxyhemoglobin ( $Hb$ ), and therefore oxygenation levels, within a tissue sample are determinable using changes in optical attenuation:

25

$$\Delta A_\lambda = -\log\left(\frac{I_{12}}{I_{11}}\right)_\lambda = \alpha_\lambda * \Delta C * d * B_\lambda \quad (\text{Eqn.2})$$

30 wherein " $A_\lambda$ " represents the optical attenuation in tissue at a particular wavelength  $\lambda$  (units: optical density or OD); " $I$ " represents the incident light intensity (units:  $W/cm^2$ ); " $\alpha_\lambda$ " represents the wavelength dependent absorption coefficient of the chromophore (units:  $OD * cm^{-1} * \mu M^{-1}$ ); " $C$ " represents the concentration of chromophore (units:  $\mu M$ ); " $d$ " represents the light source to detector (optode) separation distance (units: cm); and " $B_\lambda$ " represents the wavelength dependent light scattering differential pathlength factor (unitless)

35 [0003] To non-invasively determine oxygen saturation within tissue accurately, it is necessary to account for the optical properties (e.g., absorption coefficients or optical densities) of the tissue being interrogated. In some instances, the absorption coefficients or optical densities for the tissue components that create background light absorption and scattering can be assumed to be relatively constant over a selected wavelength range. The graph shown in FIG. 1, which includes tissue data plotted relative to a Y-axis of values representative of absorption coefficient values and an X-axis of wavelength values, illustrates such an instance. The aforesaid constant value assumption is reasonable in a test population where all of the subjects have approximately the same tissue optical properties; e.g., skin pigmentation, muscle and bone density, etc. A tissue interrogation method that relies upon such an assumption may be described as being wavelength independent within the selected wavelength range and subject independent. Our findings indicate that the same assumption is not reasonable, however, in a population of subjects having a wide spectrum of tissue optical properties (e.g., a range of significantly different skin pigmentations from very light to very dark) unless consideration for the wide spectrum of tissue optical properties is provided otherwise.

[0004] What is needed, therefore, is a method for non-invasively determining the level of oxygen saturation within biological tissue that accounts for optical influences from the specific tissue through which the light signal passes.

40 [0005] According to one aspect of the present invention, a method and apparatus for non-invasively determining the blood oxygen saturation level within a subject's tissue is provided, as defined by claims 1 and 14. In one embodiment, the method includes the steps of: 1) providing a near infrared spectrophotometric sensor operable to transmit light along a plurality of wavelengths into the subject's tissue; 2) sensing the light transmitted into the subject's tissue using the sensor, and producing signal data representative of the light sensed from the subject's tissue; 3) processing the signal data, including accounting for physical characteristics of the subject; and 4) determining the blood oxygen saturation level within the subject's tissue using a difference in attenuation between the wavelengths.

55

[0006] The apparatus includes at least one sensor having at least one light source and at least one light detector, wherein the sensor is operably connected to a processor. The light source is operable to transmit light along a plurality of wavelengths into the subject's tissue, and to produce signal data representative of the light sensed from the subject's

tissue. The algorithm selectively produces calibration constants for use with the sensor that account for the specific physical characteristics of the particular subject being sensed. The calibration constants are produced using the signal data.

**[0007]** According to another aspect of the present invention, a method for calibrating a NIRS sensor is provided that includes the steps of: 1) transmitting light into a subject's tissue using the sensor; 2) sensing the light using the sensor along a plurality of wavelengths after the light travels through the subject's tissue, and producing signal data from the sensed light; and 3) calibrating the sensor using the signal data.

**[0008]** The present method and apparatus provides advantageous accuracy. All prior art non-invasive devices and methods for determining blood oxygen saturation level within a subject's tissue, of which we are aware, do not consider the specific physical characteristics of the particular subject being sensed. The sensor is calibrated by use of assumed constants and /or relative to a source (e.g., a phantom sample, empirical data, etc.) other than the subject being sensed; i.e., calibrated in a "subject independent" manner. The present device and method, in contrast, considers the specific physical characteristics (e.g., tissue pigment, muscle and bone density and mass, etc.) of the particular subject by initially sensing the subject's tissue, creating signal data based on the sensing, and accounting for the specific physical characteristics of the subject using the signal data. The sensor, now calibrated in a "subject dependent" manner, can be used to determine the tissue blood oxygen saturation level of the subject tissue. As a result, the sensor is able to provide a more accurate assessment of the subject's blood oxygen saturation level within the tissue being sensed.

**[0009]** Another advantage of the present method and apparatus is that accurate blood oxygen saturation level information can be provided for a population of subjects having a wide range of physical characteristics. Physical characteristics (e.g., tissue pigmentation, thickness and density, etc.) naturally vary between subjects, and those characteristics create differences in light attenuation, background scattering and absorption. The present method and apparatus considers the physical characteristics of the specific subject being tested, and calibrates the sensor with signal data generated from sensing the tissue of the specific subject. Consequently, the present method and device accounts for the differences in light attenuation specific to that subject and enables the tissue blood oxygenation saturation level of subjects having a wide range of physical characteristics to be accurately sensed.

**[0010]** These and other objects, features, and advantages of the present invention method and apparatus will become apparent in light of the detailed description of the invention provided below and the accompanying drawings.

#### BRIEF DESCRIPTION OF THE DRAWINGS

**[0011]** FIG. 1 is a graph diagrammatically illustrating tissue data plotted relative to a Y-axis of values representative of absorption coefficient values, and an X-axis of wavelength values.

**[0012]** FIG. 2 is a diagrammatic representation of a NIRS sensor.

**[0013]** FIG. 3 is a diagrammatic representation of a NIRS sensor placed on a subject's head.

**[0014]** FIG. 4 is a diagrammatic view of a NIRS sensor.

**[0015]** FIG. 5 is a graph having values diagrammatically representative of subject-specific calibration coefficients plotted along a Y-axis, TOP index values plotted along an X-axis, and data representative of deoxyhemoglobin values and oxyhemoglobin values plotted therebetween with best-fit curves applied thereto.

**[0016]** FIG.6 is a flow chart illustrating steps according to one aspect of the present invention.

#### DETAILED DESCRIPTION THE INVENTION

**[0017]** The present method of and apparatus for non-invasively determining the blood oxygen saturation level within a subject's tissue is provided that utilizes a near infrared spectrophotometric (NIRS) sensor that includes a transducer capable of transmitting a light signal into the tissue of a subject and sensing the light signal once it has passed through the tissue via transmittance or reflectance. The present method and apparatus can be used with a variety of NIRS sensors, and is not therefore limited to any particular NIRS sensor.

**[0018]** Referring to FIGS. 2-4, an example of an acceptable NIRS sensor includes a transducer portion 10 and processor portion 12. The transducer portion 10 includes an assembly housing 14 and a connector housing 16. The assembly housing 14, which is a flexible structure that can be attached directly to a subject's body, includes one or more light sources 18 and light detectors 19, 20. A disposable adhesive envelope or pad is preferably used for mounting the assembly housing 14 easily and securely to the subject's skin. Light signals of known but different wavelengths from the light sources emit through a prism assembly. The light sources 18 are preferably laser diodes that emit light at a narrow spectral bandwidth at predetermined wavelengths. The laser diodes may be mounted remote from the assembly housing 14; e.g., in the connector housing 16 or within the processor portion 12. In these embodiments, a fiber optic light guide is optically interfaced with the laser diodes and the prism assembly that is disposed within the assembly housing 14. In other embodiments, the light sources 18 are mounted within the assembly housing 14. A first connector cable 26 connects the assembly housing 14 to the connector housing 16 and a second connector cable 28 connects

the connector housing 16 to the processor portion 12. The light detectors 19, 20 each include one or more photodiodes. The photodiodes are also operably connected to the processor portion 12 via the first and second connector cables 26, 28. Other examples of acceptable NIRS sensors are described in U.S. Patent Application No. 60/751,009 filed on December 16, 2005, and U.S. Patent Application No. 60/729,339 filed on October 21, 2005, both of which applications are commonly assigned to the assignee of the present application.

**[0019]** The processor portion 12 includes a processor for processing light intensity signals associated with the light sources 18 and the light detectors 19, 20 as described herein. A person of skill in the art will recognize that the processor may assume various forms (e.g., digital signal processor, analog device, etc.) capable of performing the functions described herein. The processor utilizes an algorithm that characterizes a change in attenuation as a function of the difference in attenuation between different wavelengths. The algorithm accounts for the effects of pathlength and parameter "E", which represents energy losses ("G") due to light scattering within tissue, other background absorption losses ("F") from biological compounds, and other unknown losses ("N") including measuring apparatus variability ( $E = G + F + N$ ). As will be discussed below, the parameter "E" reflects energy losses not specific to the subject being tested with a calibrated sensor (i.e., "subject-independent").

**[0020]** The absorption  $A_{b\lambda}$  detected from the deep light detector 20 includes attenuation and energy losses from both the deep and shallow tissue, while the absorption  $A_{x\lambda}$  detected from the shallow light detector 19 includes attenuation and energy losses from shallow tissue. Absorptions  $A_{b\lambda}$  and  $A_{x\lambda}$  can be expressed in the form of Equation 3 and Equation 4:

$$A_{b\lambda} = -\log\left(\frac{I_b}{I_o}\right)_\lambda = \alpha_\lambda * C_b * L_b + \alpha_\lambda * C_x * L_x + E_\lambda \quad (\text{Eqn.3})$$

$$A_{x\lambda} = -\log\left(\frac{I_x}{I_o}\right)_\lambda = \alpha_\lambda * C_x * L_x + E_{x\lambda} \quad (\text{Eqn.4})$$

In some applications (e.g., infants), a single light detector may be used, in which case Equation 5 is used:

$$A_{b\lambda} = -\log(I_b / I_o)_\lambda = \alpha_\lambda * C_b * L_b + E_\lambda \quad (\text{Eqn 5})$$

If both the deep and shallow detectors are used, then substituting Equation 4 into Equation 3 yields  $A'_\lambda$ , which represents attenuation and energy loss from deep tissue only:

$$A'_\lambda = A_{b\lambda} - A_{x\lambda} = \alpha_\lambda * C_b * L_b + (E_\lambda - E_{x\lambda}) \quad (\text{Eqn.6})$$

From Equation 5 or Equation 6, L is the effective pathlength of the photon traveling through the deep tissue and  $A'_1$  and  $A'_2$  represent light attenuation at two different wavelengths to determine differential wavelength light attenuation  $\Delta A'_{12}$ :

$$A'_1 - A'_2 = \Delta A'_{12} \quad (\text{Eqn.7})$$

Substituting Equation 5 or 6 into Equation 7 for  $A'_1$  and  $A'_2$ ,  $\Delta A'_{12}$  can be expressed as:

$$\Delta A'_{12} = \alpha_{\lambda 12} * C_b * L_b + \Delta E'_{12} \quad (\text{Eqn.8})$$

and Equation 8 can be rewritten in expanded form:

$$\Delta A'_{12} = \left( (\alpha_{r1} - \alpha_{r2}) [Hb]_b + (\alpha_{o1} - \alpha_{o2}) [HbO_2]_b \right) L_b + (E'_1 - E'_2) = \quad \text{(Eqn.9)}$$

$$\left( \Delta \alpha_{r12} * [Hb]_b * L_b \right) + \left( \Delta \alpha_{o12} * [HbO_2]_b * L_b \right) + \Delta E'_{12}$$

where:

$(\Delta \alpha_{r12} * [Hb]_b * L_b)$  represents the attenuation attributable to Hb; and  
 $(\Delta \alpha_{o12} * [HbO_2]_b * L_b)$  represents the attenuation attributable to HbO<sub>2</sub>; and

$\Delta E'_{12}$  represents energy losses due to light scattering within tissue, other background absorption losses from biological compounds, and other unknown losses including measuring apparatus variability.

**[0021]** The multivariate form of Equation 9 is used to determine  $[HbO_2]_b$  and  $[Hb]_b$  with three different wavelengths:

$$\begin{bmatrix} \Delta A'_{12} & \Delta E'_{12} \\ \Delta A'_{13} & \Delta E'_{13} \end{bmatrix} (L_b)^{-1} = \begin{bmatrix} \Delta \alpha_{r12} & \Delta \alpha_{o12} \\ \Delta \alpha_{r13} & \Delta \alpha_{o13} \end{bmatrix} \begin{bmatrix} [Hb]_b \\ [HbO_2]_b \end{bmatrix} \quad \text{(Eqn.10)}$$

Rearranging and solving for  $[HbO_2]_b$  and  $[Hb]_b$ , simplifying the  $\Delta \alpha$  matrix into  $[\Delta \alpha']$ :

$$\begin{bmatrix} \Delta A'_{12} \\ \Delta A'_{13} \end{bmatrix} [\Delta \alpha']^{-1} (L_b)^{-1} - \begin{bmatrix} \Delta E'_{12} \\ \Delta E'_{13} \end{bmatrix} [\Delta \alpha']^{-1} (L_b)^{-1} = \begin{bmatrix} [Hb]_b \\ [HbO_2]_b \end{bmatrix} \quad \text{(Eqn.11)}$$

Then combined matrices  $[\Delta A'] [\Delta \alpha']^{-1} = [A_c]$  and  $[\Delta E'] [\Delta \alpha']^{-1} = [\Psi_c]$ :

$$\begin{bmatrix} A_{Hb} \\ A_{HbO_2} \end{bmatrix} (L_b)^{-1} - \begin{bmatrix} \Psi_{Hb} \\ \Psi_{HbO_2} \end{bmatrix} (L_b)^{-1} = \begin{bmatrix} [Hb]_b \\ [HbO_2]_b \end{bmatrix} \quad \text{(Eqn.12)}$$

The parameters  $A_{Hb}$  and  $A_{HbO_2}$  represent the product of the matrices  $[\Delta A_\lambda]$  and  $[\lambda \alpha']^{-1}$  and the parameters  $\Psi_{Hb}$  and  $\Psi_{HbO_2}$  represent the product of the matrices  $[\Delta E'_\lambda]$  and  $[\Delta \alpha']^{-1}$ . To determine the level of cerebral tissue blood oxygen saturation ( $SnO_2$ ), Equation 12 is rearranged using the form of Equation 1 and is expressed as follows:

$$SnO_2 \% = \frac{(A_{HbO_2} - \Psi_{HbO_2})}{(A_{HbO_2} - \Psi_{HbO_2} + A_{Hb} - \Psi_{Hb})} * 100\% \quad \text{(Eqn.13)}$$

Note that tissue blood oxygen saturation is sometimes symbolized as  $StO_2$ ,  $SctO_2$ ,  $CrSO_2$ , or  $rSO_2$ . The effective pathlength  $L_b$  cancels out in the manipulation from Equation 12 to Equation 13.

**[0022]** The value for  $SnO_2$  is initially determined from an empirical reference of weighted combination of venous and arterial oxygen saturation ( $S_{mvO_2}$ ) value, for example using:

$$S_{mvO_2} = K_v * S_vO_2 + K_a * S_aO_2 \quad \text{(Eqn.14),}$$

and the empirically determined values for  $S_vO_2$  and  $S_aO_2$ , where the term " $S_vO_2$ " represents venous oxygen saturation, the term " $S_aO_2$ " represents arterial oxygen saturation, and the terms  $K_v$  and  $K_a$  are the weighted venous and arterial

contributions respectively ( $K_V + K_A = 1$ ). The empirically determined values for  $S_{VO_2}$  and  $SaO_2$  are based on data developed by discrete sampling or continuous monitoring of the subject's blood performed at or about the same time as the sensing of the tissue with the sensor; e.g., blood samples discretely collected can be analyzed by blood gas analysis and blood samples continuously monitored can be analyzed using a fiber optic catheter inserted within a blood vessel.

5 The temporal and physical proximity of the NIRS sensing and the development of the empirical data helps assure accuracy. The initial values for  $K_V$  and  $K_A$  within Equation 14 are clinically reasonable values for the circumstances at hand. The values for  $A_{HbO_2}$  and  $A_{Hb}$  are determined mathematically using the values for  $I_{b\lambda}$  and  $I_{x\lambda}$  for each wavelength sensed with the NIRS sensor (e.g., using Equation 3 & 4 for deep and shallow detectors or Equation 5 for a single detector). The calibration parameters  $\Psi_{Hb}$  and  $\Psi_{HbO_2}$ , which account for energy losses due to scattering as well as other background absorption from biological compounds, are then determined using Equation 14 and non-linear regression techniques by correlation to different weighted values of  $S_{VO_2}$  and  $SaO_2$ ; i.e., different values of  $K_A$  and  $K_V$ . Statistically acceptable values of  $K_V$  and  $K_A$  and  $\Psi_{Hb}$  and  $\Psi_{HbO_2}$  are converged upon using the non-linear regression techniques. Experimental findings show that with proper selection of  $K_A$  and  $K_V$ , the calibration parameters  $\Psi_{Hb}$  and  $\Psi_{HbO_2}$  are constant within a statistically acceptable margin of error for an individual NIRS sensor used to monitor brain oxygenation on different human subjects.

15 **[0023]** The above-identified process produces a NIRS sensor calibrated relative to a particular subject using invasive techniques, or a NIRS sensor calibrated relative to an already calibrated sensor (or relative to a phantom sample). When these calibrated sensors are used thereafter on a different subject; they do not account for the specific physical characteristics of the particular subject being tested. The present method and apparatus as described below permits a NIRS sensor to be calibrated in a non-invasive manner that accounts for specific physical characteristics of the particular subject being sensed.

20 **[0024]** Certain physical characteristics will vary from subject to subject; such as but not limited to, tissue pigmentation and thickness and density of muscle and/or bone. The present method and apparatus accounts for background tissue's wavelength dependent light attenuation differences due to these subject-dependent physical characteristics by sensing the subject's tissue, creating signal data from the sensing, and using the signal data to create one or more "subject-specific" calibration constants that account for the specific characteristics of the subject. For example, during an initial phase of monitoring, light is transmitted into and sensed passing out of the subject's tissue. Signal data representative of the sensed light is analyzed to account for the physical characteristics of the subject, and one or more subject-specific calibration constants indicative of the specific physical characteristics are created. The subject-specific calibration constants are subsequently used to determine properties such as the blood oxygen saturation level, deoxyhemoglobin concentration, oxyhemoglobin concentration, etc.

25 **[0025]** The subject-specific calibration constants can be determined by using the sensed signal data to create a tissue optical property (TOP) index value. The TOP index value is derived from wavelength dependent light attenuation attributable to physical characteristics such as tissue pigmentation, thickness and density of tissue, etc. These physical characteristics are collectively considered in determining the TOP index value because the characteristics have absorption coefficients that increase with decreasing wavelength from the near-infrared region to the red region (i.e., from about 900nm to about 400 nm) mainly due to the presence of melanin, the light absorbing pigmentation in skin and tissue. For example, it has been reported by S. L. Jacques et al., that light absorption in skin due to melanin can be described by the relationship:  $\mu_a = 1.70 \times 10^{12} (\text{wavelength in nm})^{-3.48} [\text{cm}^{-1}]$  in the wavelength range from about 400nm to about 850 nm. If the overall light absorption characteristics of tissue are modeled to follow that of melanin, then the TOP light absorption coefficients ( $\alpha_{TOP}$ ) can be determined using the same equation for the particular wavelengths of light used in the interrogation of the tissue (where  $A = 1.7 \times 10^{12}$  and  $T = -3.48$ ):

30

$$\alpha_{TOP} = A * (\text{wavelength})^{-T} \quad (\text{Eqn. 15})$$

45

To determine the TOP index value, one or more of the wavelengths in the near-infrared region to the red region (i.e., from about 900nm to about 600 nm; e.g., 690 nm, 780 nm, 805 nm, 850 nm) are sensed. Red wavelengths are favored because red light is more sensitive to the tissue optical properties than infrared light. Lower wavelengths of light could also be used, but suffer from increased attenuation from the higher tissue and hemoglobin absorption coefficients, resulting in reduced tissue penetration, reduced detected light signal strength, and resultant poor signal to noise ratio.

50 **[0026]** To calculate the TOP index value (identified in Equation 16 as "TOP"), a four wavelength, three unknown differential attenuation algorithm (following similarly to the derivation shown by Equations 3-10), is used such as that shown in Equation 16:

55

$$\begin{bmatrix} \Delta A'_{12} \\ \Delta A'_{13} \\ \Delta A'_{14} \end{bmatrix} (L_b)^{-1} = \begin{bmatrix} \Delta \alpha'_{r12} & \Delta \alpha'_{o12} & \Delta \alpha'_{TOP12} \\ \Delta \alpha'_{r13} & \Delta \alpha'_{o13} & \Delta \alpha'_{TOP13} \\ \Delta \alpha'_{r14} & \Delta \alpha'_{o14} & \Delta \alpha'_{TOP14} \end{bmatrix} \begin{bmatrix} Hb \\ HbO_2 \\ TOP \end{bmatrix} \quad (\text{Eqn.16})$$

Alternatively, Equation 17 shown below could be used. Equation 17 accounts for energy losses "E" as described above:

$$\begin{bmatrix} \Delta A'_{12} & \Delta E'_{12} \\ \Delta A'_{13} & \Delta E'_{13} \\ \Delta A'_{14} & \Delta E'_{14} \end{bmatrix} (L_b)^{-1} = \begin{bmatrix} \Delta \alpha'_{r12} & \Delta \alpha'_{o12} & \Delta \alpha'_{TOP12} \\ \Delta \alpha'_{r13} & \Delta \alpha'_{o13} & \Delta \alpha'_{TOP13} \\ \Delta \alpha'_{r14} & \Delta \alpha'_{o14} & \Delta \alpha'_{TOP14} \end{bmatrix} \begin{bmatrix} Hb \\ HbO_2 \\ TOP \end{bmatrix} \quad (\text{Eqn. 17})$$

**[0027]** The TOP index value determinable from Equations 16 or 17 accounts for subject tissue optical properties variability and can be converted to a "corrective" factor used to determine accurate tissue blood oxygen saturation  $SnO_2$ . In some embodiments, the TOP index value can be used with a database to determine subject-specific calibration constants (e.g.,  $Z_{Hb}$  and  $Z_{HbO_2}$ ). The database contains data, at least some of which is empirically collected, pertaining to oxyhemoglobin and deoxyhemoglobin concentrations for a plurality of subjects. The concentration data is organized relative to a range of TOP index values in a manner that enables the determination of the subject-specific calibration constants. The organization of the information within the database can be accomplished in a variety of different ways.

**[0028]** For example, the empirical database may be organized in the form of a graph having subject-specific calibration coefficients plotted along the y-axis versus TOP index values plotted along the x-axis. An example of such a graph is shown in FIG. 5, which contains data 30 representing the differences between calculated deoxyhemoglobin values (Hb) values and empirically derived deoxyhemoglobin values (the differences referred to in FIG.5 as "Hb-offset2 data"), and a best fit curve 32 applied to a portion of that data 30. The graph also contains data 34 representing the differences between calculated oxyhemoglobin values (HbO2) values and empirically derived oxyhemoglobin values (the differences referred to in FIG.5 as "HbO2-offset2 data"), and another best-fit curve 36 applied to a portion of that data 34. In the example shown in FIG. 5, a statistically significant number of the data 30, 34 for each curve lies within the sloped portion 32a, 36a (i.e., the portion that does not have a constant calibration constant value). At each end of the sloped portion 32a, 36a, the curves 32, 36 are depicted as having constant calibration values 32b, 32c, 36b, 36c for convenience sake. The values for the subject-specific calibration coefficients  $Z_{Hb}$  and  $Z_{HbO_2}$  are determined by drawing a line (e.g., see phantom line 38) perpendicular to the TOP index value axis at the determined TOP index value. The subject-specific calibration constant ( $Z_{Hb}$ ) for deoxyhemoglobin is equal to the value on the calibration constant axis aligned with the intersection point between the perpendicular line and the "Hb-offset2" curve, and the subject-specific calibration constant ( $Z_{HbO_2}$ ) for oxyhemoglobin is equal to the value on the calibration constant axis aligned with the intersection point with the "HbO2-offset2" curve.

**[0029]** Alternatively, the subject-specific calibration constant values may be determined using an empirical database in a form other than a graph. For example, a mathematical solution can be implemented rather than the above-described graph. The mathematical solution may use linear equations representing the "Hb-offset2" and the "HbO2-offset2" curves.

**[0030]** Once the subject-specific calibration constant values are determined, they are utilized with a variation of Equation 13:

$$SnO_2 \% = \frac{(A_{HbO_2} - \Psi_{HbO_2} + Z_{HbO_2})}{(A_{HbO_2} - \Psi_{HbO_2} + Z_{HbO_2} + A_{Hb} - \Psi_{Hb} + Z_{Hb})} * 100\% \quad (\text{Eqn. 18})$$

to determine the cerebral blood oxygen saturation level.

**[0031]** The above-described process for determining the subject-specific calibration constants can be performed one or more times in the initial period of sensing the subject to calibrate the sensor to that particular subject, preferably right after the sensor is attached to the subject. The subject-dependent calibration constants can then be used with an algorithm for measurement of a subject's blood oxygen saturation level using the same or different signal data. The

algorithm in which the subject-dependent calibration constants are utilized may be the same algorithm as used to determine the constants, or a different algorithm for determining the tissue oxygen saturation level. For example, calibration constants can be used with the three wavelength method disclosed above in Equations 2 - 14, and in U.S. Patent No. 6,456,862. Prior to the cerebral blood oxygen saturation level being calculated, the subject-specific calibration constants  $Z_{Hb}$  and  $Z_{HbO_2}$  can be incorporated as corrective factors into the three wavelength algorithm (e.g., incorporated into Eqn. 13). As a result, a more accurate determination of the subject's tissue oxygen saturation level is possible. FIG. 6 illustrates the above described steps within a flow chart.

**[0032]** In alternative embodiments not forming part of the invention, the TOP index methodology disclosed above can be used within an algorithm in a subject-independent manner. This approach does not provide all of the advantages of the above described subject-dependent methodology and apparatus, but does provide improved accuracy by specifically accounting for subject skin pigmentation. For example, the TOP absorption coefficients can be determined as described above and utilized within Equation 16 or Equation 17. Regardless of the equation used, the determined values for deoxyhemoglobin (Hb) and oxyhemoglobin (HbO<sub>2</sub>) can subsequently be used to determine the tissue oxygen saturation level. For example, the Hb and HbO<sub>2</sub> values can be utilized within Equations 11 through 13.

**[0033]** Although the present method and apparatus are described above in terms of sensing blood oxygenation within cerebral tissue, the present method and apparatus are not limited to cerebral applications and can be used to determine tissue blood oxygenation saturation within tissue found elsewhere within the subject's body. If the present invention is utilized to determine the tissue blood oxygenation saturation percentage is typically symbolized as StO<sub>2</sub> or rSO<sub>2</sub>.

## Claims

1. A method for non-invasively determining a blood oxygen saturation level within a subject's tissue, comprising the steps of:

providing a spectrophotometric sensor operable to transmit light along a plurality of wavelengths into the subject's tissue, and to sense the light;  
calibrating the sensor by:

transmitting light into the subject's tissue using the sensor;  
sensing the light using the sensor along a plurality of wavelengths after the light travels through the subject's tissue, and producing signal data from the sensed light; and  
calibrating the sensor using the signal data to create one or more subject-specific calibration constants that account for specific physical characteristics of the particular subject's tissue being sensed; and

using the subject-dependent calibration constants to determine the blood oxygen saturation level within the subject's tissue.

2. The method of claim 1, wherein the physical characteristics of the subject's tissue include pigmentation.

3. The method of claim 2, wherein the calibrating step includes the use of absorption coefficients for pigmentation in the subject's tissue.

4. The method of claim 3, wherein the calibrating step determines one or more calibration constants using the absorption coefficients for pigmentation, the calibration constants being used within the step of determining the blood oxygen saturation level within the subject's tissue.

5. The method of claim 4, wherein the step of determining the blood oxygen saturation level within the subject's tissue comprises processing signal data other than that used to create the one or more calibration constants.

6. The method of claim 1, wherein the blood oxygen saturation level is determined using a difference in attenuation between the wavelengths.

7. The method of claim 1, wherein the blood oxygen saturation level within the subject's tissue is determined using a difference in attenuation between wavelengths and the calibration constants.

8. The method of claim 7, wherein the step of determining the blood oxygen saturation level within the subject's tissue comprises processing signal data other than that used to create the one or more calibration constants.

9. The method of claim 7 or 8, wherein the blood oxygen saturation level within the subject's tissue is determined using a difference in attenuation between a first of the wavelengths and each of the other of the wavelengths.

5 10. The method of any of claims 7-9, wherein creating the one or more calibration constants includes the use of absorption coefficients for pigmentation in the subject's tissue.

11. The method of any preceding claim, further comprising the step of determining the concentration of oxyhemoglobin and/or deoxyhemoglobin within the subject's tissue.

10 12. The method of claim 11, wherein the signal data is processed to initially determine the concentration of oxyhemoglobin, deoxyhemoglobin, and pigmentation within the subject's tissue, and subsequently to determine the blood oxygen saturation level within the subject's tissue using the determined concentrations of oxyhemoglobin and deoxyhemoglobin.

15 13. The method of any preceding claim, wherein the spectrophotometric sensor is operable to transmit light within a predetermined range of wavelengths into the subject's tissue, and further comprising the step of:

processing the signal data, including determining light attenuation for one or more components of the subject's tissue, other than oxyhemoglobin and  
20 deoxyhemoglobin, which components have a tissue optical property that varies over the range of wavelengths, to determine the blood oxygen saturation level within the subject's tissue.

14. An apparatus for non-invasively determining a blood oxygen saturation level within a subject's tissue, comprising:

25 at least one spectrophotometric sensor (10) having at least one light source (18) and at least one light detector (19, 20), wherein the light source is operable to transmit light along a plurality of wavelengths into the subject's tissue, and the light detector is operable to detect light from the light source after the light has travelled through the subject's tissue, and the sensor is operable to produce initial signal data representative of the detected light;  
and

30 a processor (12) operably connected to the at least one sensor, the processor having an algorithm operable to process the initial signal data to account for the physical characteristics of the subject's tissue and to calibrate the at least one sensor to that particular subject using the initial signal data to create one or more subject-specific calibration constants that account for specific physical characteristics of the particular subject's tissue being sensed.

35 15. The apparatus of claim 14, wherein the physical characteristics of the subject's tissue include pigmentation and wherein the algorithm utilizes absorption coefficients for pigmentation in the subject's tissue.

40 16. The apparatus of claim 15, wherein the algorithm is operable to process the initial signal data to determine one or more calibration constants using the absorption coefficients for pigmentation, and operable to determine the blood oxygen saturation level within the subject's tissue using the calibration constant(s).

45 17. The apparatus of claim 16, wherein the algorithm is operable to determine the blood oxygen saturation level within the subject's tissue using signal data other than that used to create the one or more calibration constants.

## Patentansprüche

50 1. Verfahren zur nicht-invasiven Bestimmung eines Blutsauerstoffsättigungsgrads in dem Gewebe einer Person, welches die Folgenden Schritte aufweist:

Bereitstellen eines spektralphotometrischen Sensors, der zur Aussendung von Licht entlang einer Vielzahl von Wellenlinien in das Gewebe der Person und zum Erfassen des Lichts betreibbar ist; wobei der Sensor kalibriert wird durch:

55 Aussenden von Licht in das Gewebe der Person unter Verwendung des Sensors;  
Erfassen des Lichts unter Verwendung des Sensors entlang einer Vielzahl von Wellenlängen, nachdem das Licht durch das Gewebe der Person gelaufen ist, und Erzeugen von Signaldaten von dem erfassten

Licht; und

Kalibrieren des Sensors unter Verwendung der Signaldaten zur Erzeugung von einer oder mehreren personenspezifischen Kalibrierungskonstanten, welche die spezifischen physikalischen Eigenschaften von dem jeweiligen Gewebe der Person, das erfasst wird, berücksichtigen; und

5

Verwenden der personenabhängigen Kalibrierungskonstanten zum Bestimmen des Blutsauerstoffsättigungsgrads in dem Gewebe der Person.

10

2. Verfahren nach Anspruch 1, wobei die physikalischen Eigenschaften von dem Gewebe der Person Pigmentierung umfassen.

3. Verfahren nach Anspruch 2, wobei der Kalibrierungsschritt die Verwendung von Absorptionskoeffizienten für die Pigmentierung in dem Gewebe der Person umfasst.

15

4. Verfahren nach Anspruch 3, wobei der Kalibrierungsschritt eine oder mehrere Kalibrierungskonstanten unter Verwendung der Absorptionskoeffizienten für die Pigmentierung bestimmt, wobei die Kalibrierungskonstanten in dem Schritt zur Bestimmung des Blutsauerstoffsättigungsgrads in dem Gewebe der Person verwendet werden.

20

5. Verfahren nach Anspruch 4, wobei der Schritt der Bestimmung des Blutsauerstoffsättigungsgrads in dem Gewebe der Person die Weiterverarbeitung von anderen Signaldaten umfasst, als denjenigen, die zur Erzeugung von einer oder mehreren Kalibrierungskonstanten verwendet wurden.

25

6. Verfahren nach Anspruch 1, wobei der Blutsauerstoffsättigungsgrad unter Verwendung eines Unterschiedes in der Abschwächung zwischen den Wellenlängen verwendet wird.

7. Verfahren nach Anspruch 1, wobei der Blutsauerstoffsättigungsgrad in dem Gewebe der Person unter Verwendung eines Unterschiedes in der Abschwächung zwischen den Wellenlängen und den Kalibrierungskonstanten verwendet wird.

30

8. Verfahren nach Anspruch 7, wobei der Schritt der Bestimmung des Blutsauerstoffsättigungsgrads in dem Gewebe der Person die Weiterverarbeitung von anderen Signaldaten umfasst, als denjenigen, die zur Erzeugung von einer oder mehreren Kalibrierungskonstanten verwendet wurden.

35

9. Verfahren nach Anspruch 7 oder 8, wobei der Blutsauerstoffsättigungsgrad in dem Gewebe der Person unter Verwendung eines Unterschieds in der Abschwächung zwischen einer ersten der Wellenlängen und jeder der anderen Wellenlängen verwendet wird.

40

10. Verfahren nach einem der Ansprüche 7-9, wobei die Erzeugung der einen oder mehreren Kalibrierungskonstanten die Verwendung von Absorptionskoeffizienten für die Pigmentierung in dem Gewebe der Person umfasst.

11. Verfahren nach einem der vorangehenden Ansprüche, die ferner den Schritt umfasst von:

dem Bestimmen der Konzentration von Oxyhämoglobin und/oder Deoxyhämoglobin in dem Gewebe der Person.

45

12. Verfahren nach Anspruch 11, wobei die Signaldaten weiterverarbeitet werden, um zunächst die Konzentration von Oxyhämoglobin, Deoxyhämoglobin und Pigmentierung in dem Gewebe der Person zu bestimmen und daran anschließend den Blutsauerstoffsättigungsgrad in dem Gewebe der Person unter Verwendung der bestimmten Konzentrationen von Oxyhämoglobin und Deoxyhämoglobin zu bestimmen.

50

13. Verfahren nach einem der vorhergehenden Ansprüche, wobei der spektralphotometrische Sensor zum Aussenden von Licht in einem vorgegebenen Bereich der Wellenlängen in das Gewebe der Person betreibbar ist und das Verfahren ferner den Schritt umfasst von:

55

dem Weiterverarbeiten der Signaldaten, was die Bestimmung der Lichtabschwächung für eine oder mehrere Komponenten des Gewebes der Person mit Ausnahme von Oxyhämoglobin und Deoxyhämoglobin umfasst, wobei die Komponenten eine optische Eigenschaft aufweisen, die sich über den Bereich der Wellenlängen verändert, um den Blutsauerstoffsättigungsgrad in dem Gewebe der Person zu bestimmen.

14. Vorrichtung zur nicht-invasiven Bestimmung eines Blutsauerstoffsättigungsgrads in dem Gewebe einer Person, die Folgendes aufweist:

5 mindestens einen spektralphotometrischen Sensor (10) mit mindestens einer Lichtquelle (18) und mindestens einem Lichtdetektor (19, 20), wobei die Lichtquelle zum Aussenden von Licht entlang einer Vielzahl von Wellenlängen in das Gewebe der Person betreibbar ist und der Lichtdetektor zum Nachweisen von Licht aus der Lichtquelle betreibbar ist, nachdem das Licht durch das Gewebe der Person hindurchgelaufen ist, und der Sensor zur Erzeugung von anfänglichen Signaldaten, die für das nachgewiesene Licht kennzeichnend sind, betreibbar ist; und

10 einen Prozessor (12), der funktionsmäßig mit dem mindestens einen Sensor verbunden ist, wobei der Prozessor einen Algorithmus aufweist, der zur Weiterverarbeitung der anfänglichen Signaldaten betreibbar ist, um die physikalischen Eigenschaften von dem Gewebe der Person zu berücksichtigen und den mindestens einen Sensor für die bestimmte Person unter Verwendung der anfänglichen Signaldaten zur Erzeugung von einer oder mehreren personenspezifischen Kalibrierungskonstanten zu kalibrieren, welche die spezifischen physikalischen Eigenschaften des jeweiligen Gewebes der Person, das erfasst wird, berücksichtigen.

- 15 15. Vorrichtung nach Anspruch 14, wobei die physikalischen Eigenschaften von dem Gewebe der Person die Pigmentierung umfassen und wobei der Algorithmus die Absorptionskoeffizienten für die Pigmentierung in dem Gewebe der Person verwendet.

- 20 16. Vorrichtung nach Anspruch 15, wobei der Algorithmus zur Weiterverarbeitung der anfänglichen Signaldaten betreibbar ist, um die eine oder mehreren Kalibrierungskonstanten unter Verwendung der Absorptionskoeffizienten für die Pigmentierung zu bestimmen und zur Bestimmung des Blutsauerstoffsättigungsgrads in dem Gewebe der Person unter Verwendung der Kalibrierungskonstante(n) betreibbar ist.

- 25 17. Vorrichtung nach Anspruch 16, wobei der Algorithmus zur Bestimmung des Blutsauerstoffsättigungsgrads in dem Gewebe der Person unter Verwendung von anderen Signaldaten umfasst, als denjenigen, die zur Erzeugung von einer oder mehreren Kalibrierungskonstanten verwendet wurden.

30 **Revendications**

- 35 1. Procédé pour déterminer de manière non invasive un niveau de saturation de l'oxygène du sang dans un tissu d'un sujet, comprenant les étapes consistant à :

mettre en oeuvre un capteur spectrophotométrique qui est à même de transmettre de la lumière le long d'une pluralité de longueurs d'onde dans le tissu du sujet et de détecter la lumière ;  
étalonner le capteur par :

- 40 - transmission de lumière dans le tissu du sujet en utilisant le capteur ;  
- détection de la lumière en utilisant le capteur dans une pluralité de longueurs d'onde après que la lumière a traversé le tissu du sujet et production de données de signal à partir de la lumière détectée ; et  
- étalonnage du capteur en utilisant les données de signal pour créer un ou plusieurs constantes d'étalonnage spécifiques au sujet qui tiennent compte des caractéristiques physiques spécifiques du tissu du sujet particulier détecté ; et

45 utiliser les constantes d'étalonnage dépendant du sujet pour déterminer le niveau de saturation d'oxygène du sang dans le tissu du sujet.

- 50 2. Procédé selon la revendication 1, dans lequel les caractéristiques physiques du tissu du sujet comprennent la pigmentation.

- 55 3. Procédé selon la revendication 2, dans lequel l'étape d'étalonnage comprend l'utilisation de coefficients d'absorption pour la pigmentation dans le tissu du sujet.

4. Procédé selon la revendication 3, dans lequel l'étape d'étalonnage détermine une constante d'étalonnage ou plus en utilisant les coefficients d'absorption pour la pigmentation, les constantes d'étalonnage étant utilisées dans l'étape de détermination du niveau de saturation de l'oxygène du sang dans le tissu du sujet.

## EP 1 885 235 B1

5. Procédé selon la revendication 4, dans lequel l'étape de détermination du niveau de saturation de l'oxygène du sang dans le tissu du sujet comprend le traitement de données de signal autres que celles utilisées pour créer la ou les constantes d'étalonnage.
- 5 6. Procédé selon la revendication 1, dans lequel le niveau de saturation de l'oxygène du sang est déterminé en utilisant une différence d'atténuation entre les longueurs d'onde.
7. Procédé selon la revendication 1, dans lequel le niveau de saturation de l'oxygène du sang dans le tissu du sujet est déterminé en utilisant une différence d'atténuation entre les longueurs d'onde et les constantes d'étalonnage.
- 10 8. Procédé selon la revendication 7, dans lequel l'étape de détermination du niveau de saturation de l'oxygène du sang dans le tissu du sujet comprend le traitement de données de signal autres que celles utilisées pour créer la ou les constantes d'étalonnage.
- 15 9. Procédé selon la revendication 7 ou la revendication 8, dans lequel le niveau de saturation de l'oxygène du sang dans le tissu du sujet est déterminé en utilisant une différence d'atténuation entre une première des longueurs d'onde et chacune des autres longueurs d'onde.
- 20 10. Procédé selon l'une quelconque des revendications 7 à 9, dans lequel la création de la ou des constantes d'étalonnage comprend l'utilisation de coefficients d'absorption pour la pigmentation dans le tissu du sujet.
11. Procédé selon l'une quelconque des revendications précédentes, comprenant en outre l'étape consistant à :
- 25 déterminer la concentration d'oxyhémoglobine et/ou de désoxyhémoglobine dans le tissu du sujet.
12. Procédé selon la revendication 11, dans lequel les données de signal sont traitées pour déterminer initialement la concentration d'oxyhémoglobine, de désoxyhémoglobine et de pigmentation dans le tissu du sujet et pour déterminer ensuite le niveau de saturation de l'oxygène du sang dans le tissu du sujet en utilisant les concentrations déterminées d'oxyhémoglobine et de désoxyhémoglobine.
- 30 13. Procédé selon l'une quelconque des revendications précédentes, dans lequel le capteur spectrophotométrique est à même de transmettre de la lumière dans une plage prédéterminée de longueurs d'onde dans le tissu du sujet et comprenant par ailleurs l'étape consistant à :
- 35 traiter les données de signal, notamment déterminer l'atténuation de la lumière pour un ou plusieurs composants du tissu du sujet, autres que l'oxyhémoglobine et la désoxyhémoglobine, lesquels composants ont une propriété optique tissulaire qui varie sur la plage de longueurs d'onde, pour déterminer le niveau de saturation d'oxygène du sang dans le tissu du sujet.
- 40 14. Appareil pour déterminer de manière non invasive un niveau de saturation d'oxygène du sang dans un tissu de sujet, comprenant :
- 45 au moins un capteur spectrophotométrique (10) ayant au moins une source de lumière (18) et au moins un détecteur de lumière (19, 20), dans lequel la source de lumière est à même de transmettre de la lumière le long d'une pluralité de longueurs d'onde dans le tissu du sujet et le détecteur de lumière est à même de détecter de la lumière provenant de la source de lumière une fois que la lumière s'est déplacée à travers le tissu du sujet, et le capteur est à même de produire des données de signal initiales représentatives de la lumière détectée ; et un processeur (12) raccordé en service au au moins un capteur, le processeur ayant un algorithme qui est à même de traiter les données de signal initiales pour tenir compte des caractéristiques physiques du tissu du sujet et pour étalonner le au moins un capteur à ce sujet particulier en utilisant les données de signal initiales afin de créer une ou plusieurs constantes d'étalonnage spécifiques au sujet qui tiennent compte de caractéristiques physiques spécifiques du tissu détecté du sujet particulier.
- 50 15. Appareil selon la revendication 14, dans lequel les caractéristiques physiques du tissu du sujet comprennent la pigmentation et dans lequel l'algorithme utilise des coefficients d'absorption pour la pigmentation dans le tissu du sujet.
- 55 16. Appareil selon la revendication 15, dans lequel l'algorithme est à même de traiter les données de signal initiales

## EP 1 885 235 B1

pour déterminer une constante d'étalonnage ou plus en utilisant les coefficients d'absorption pour la pigmentation et à même de déterminer le niveau de saturation de l'oxygène du sang dans le tissu du sujet en utilisant la ou les constantes d'étalonnage.

- 5 17. Appareil selon la revendication 16, dans lequel l'algorithme est à même de déterminer le niveau de saturation d'oxygène du sang dans le tissu du sujet en utilisant des données de signal autres que celles utilisées pour créer la ou les constantes d'étalonnage.

10

15

20

25

30

35

40

45

50

55

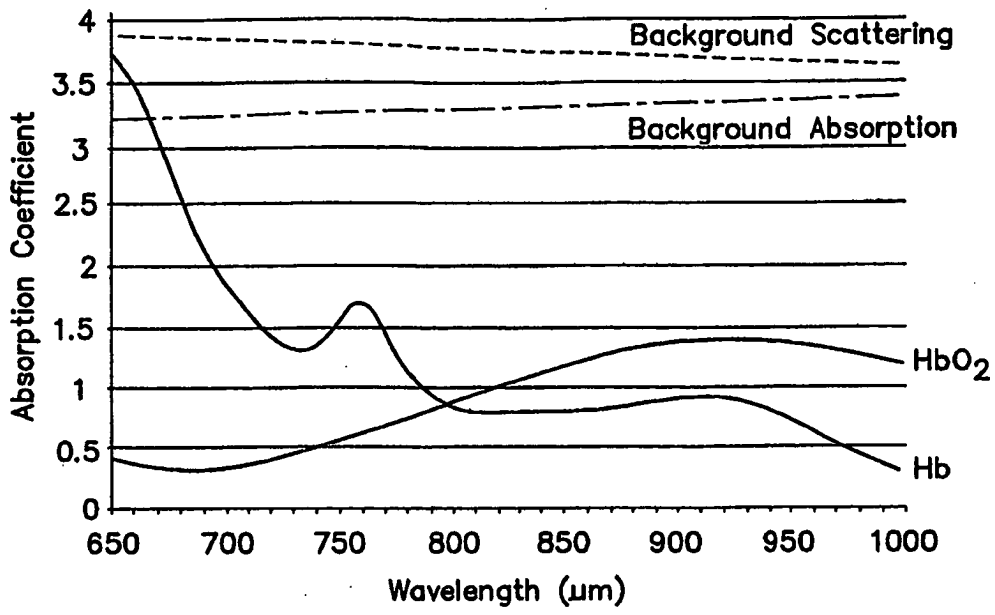

FIG. 1

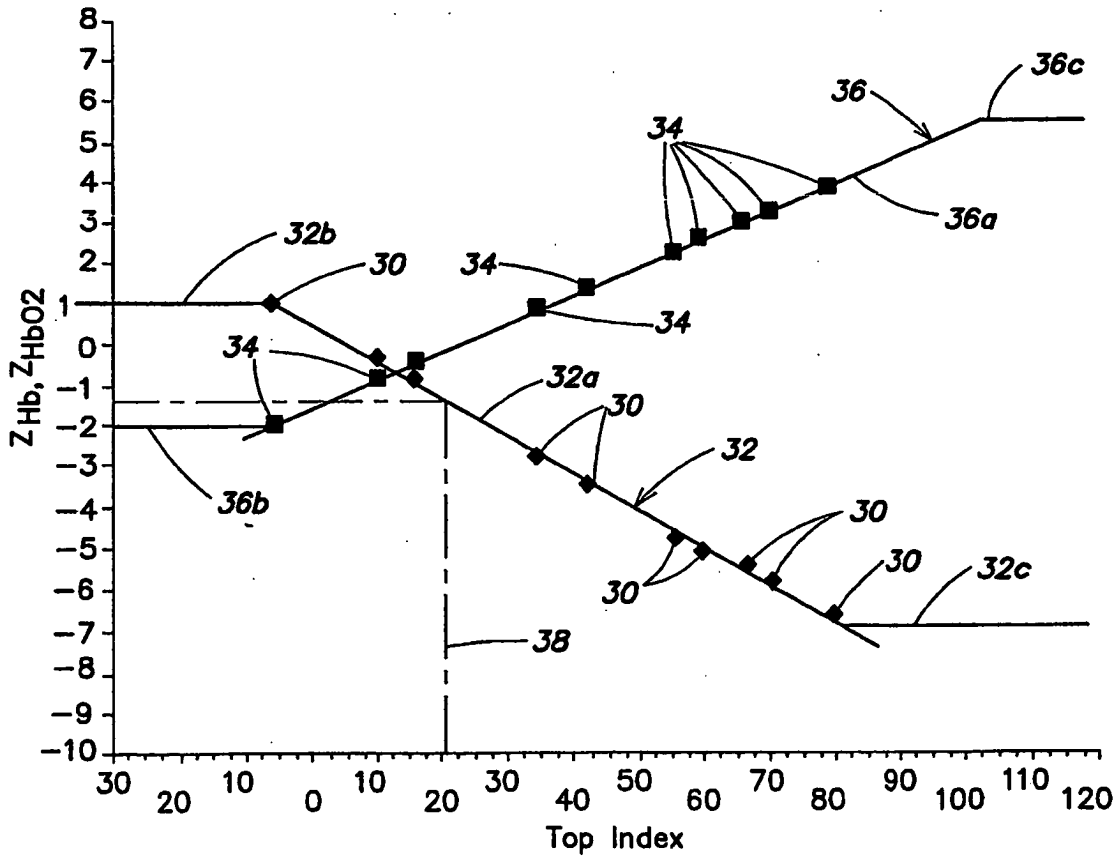
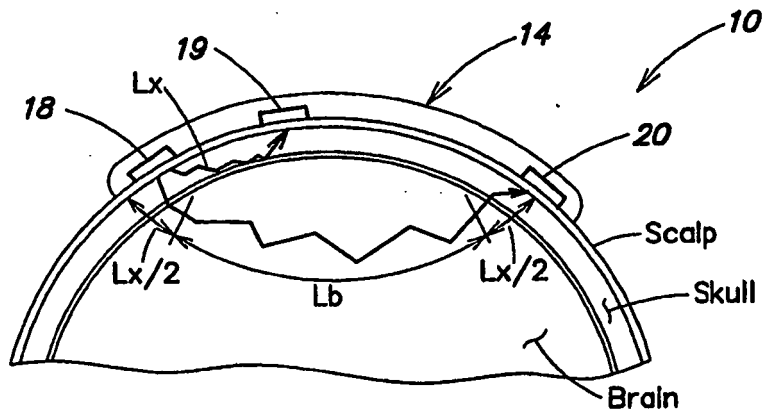
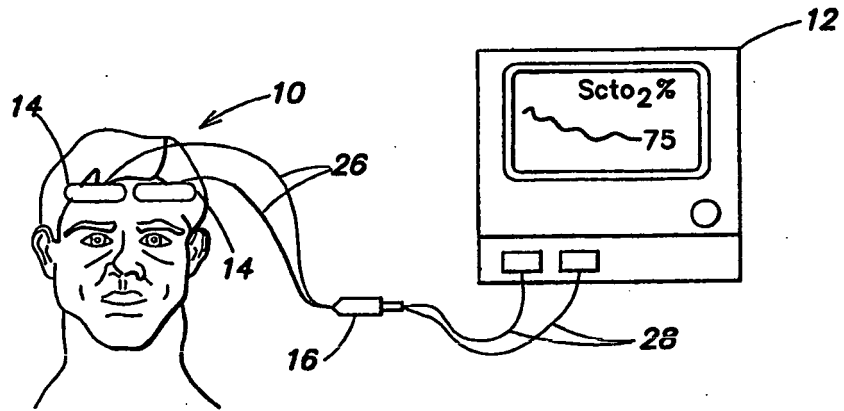

FIG. 5



**FIG. 2**



**FIG. 3**

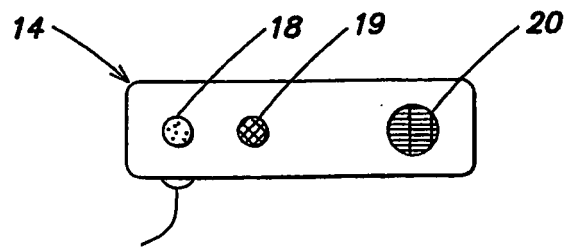

**FIG. 4**

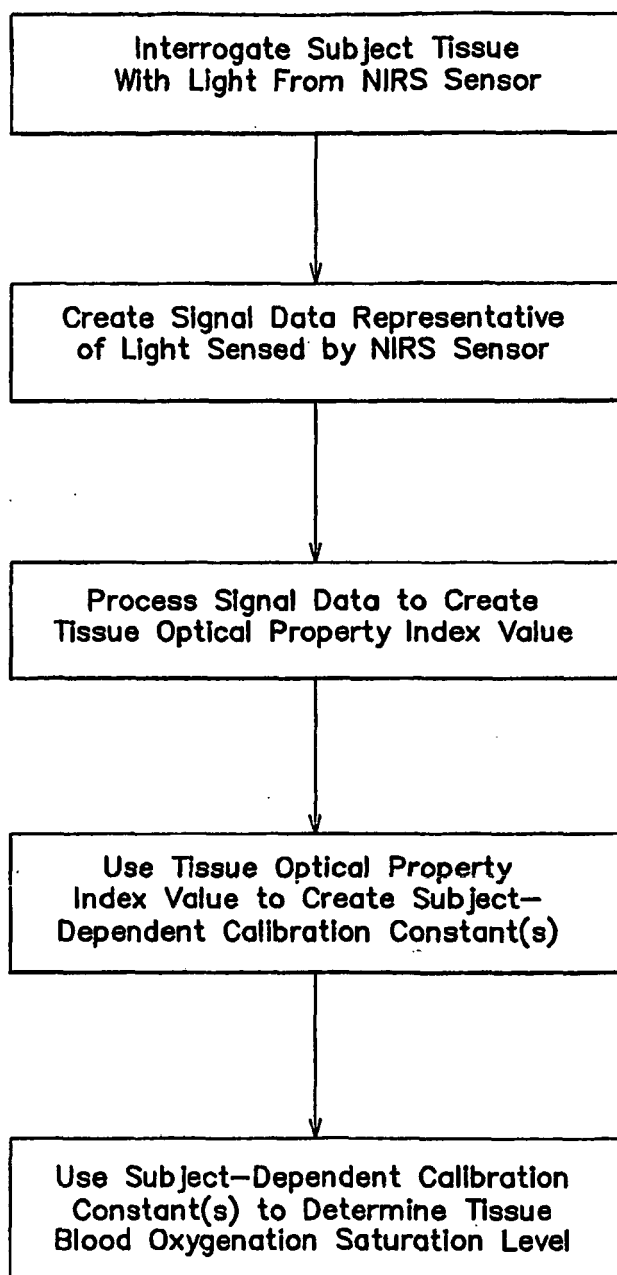

**FIG. 6**

**REFERENCES CITED IN THE DESCRIPTION**

*This list of references cited by the applicant is for the reader's convenience only. It does not form part of the European patent document. Even though great care has been taken in compiling the references, errors or omissions cannot be excluded and the EPO disclaims all liability in this regard.*

**Patent documents cited in the description**

- US 6456862 B [0002] [0031]
- WO 2004010844 A [0002]
- US 75100905 P [0018]
- US 72933905 P [0018]

专利名称(译)	改进的分光光度法血氧监测方法		
公开(公告)号	<a href="#">EP1885235B1</a>	公开(公告)日	2013-12-18
申请号	EP2006770173	申请日	2006-05-10
申请(专利权)人(译)	CAS医疗系统, INC.		
当前申请(专利权)人(译)	CAS医疗系统, INC.		
[标]发明人	BENNI PAUL B		
发明人	BENNI, PAUL, B.		
IPC分类号	A61B5/00 G01N21/25 A61B5/1455 A61B5/1495		
CPC分类号	A61B5/14551 A61B5/0205 A61B5/0261 A61B5/14546 A61B5/14552 A61B5/14553 A61B5/1495 A61B5/6814 G01N21/359 G01N21/49 G01N2021/3144		
优先权	60/680192 2005-05-12 US		
其他公开文献	EP1885235A4 EP1885235A1		
外部链接	<a href="#">Espacenet</a>		

摘要(译)

提供了一种用于非侵入性地确定对象组织内的血氧饱和度水平的方法和设备。分光光度传感器可操作以将光透射到受试者的组织中并感测光。该方法包括以下步骤：使用传感器感测对象的组织，以及从感测对象的组织产生信号数据；以及处理信号数据，包括考虑所感测的特定对象组织的特定物理特性；用从感测特定对象的组织产生的信号数据校准传感器；并使用校准后的传感器确定受试者组织内的血氧饱和度。已经以“取决于受试者”的方式校准的传感器能够提供受试者在组织内的血氧饱和度水平的更准确的评估。

$$O_2 \text{ saturation} \% = \frac{HbO_2}{(HbO_2 + Hb)} * 100\% \quad (\text{Eqn. 1})$$