



(11) **EP 1 741 384 B1**

(12) **EUROPEAN PATENT SPECIFICATION**

(45) Date of publication and mention of the grant of the patent:  
**11.11.2009 Bulletin 2009/46**

(51) Int Cl.:  
**A61B 5/00 (2006.01)**

(21) Application number: **06253582.8**

(22) Date of filing: **07.07.2006**

(54) **A system for adjusting power employed by a medical device**

System zur Leistungseinstellung für eine medizinische Vorrichtung

Système pour ajuster la puissance employée par un appareil médical

(84) Designated Contracting States:  
**DE FR GB**

(30) Priority: **08.07.2005 US 697615 P**

(43) Date of publication of application:  
**10.01.2007 Bulletin 2007/02**

(73) Proprietor: **Draeger Medical Systems, Inc.**  
**Andover, MA 01810 (US)**

(72) Inventor: **Huang, Johnnie**  
**Hillsborough, California 94010 (US)**

(74) Representative: **Vinsome, Rex Martin et al**  
**Urquhart-Dykes & Lord LLP**  
**Cale Cross House**  
**Pilgrim Street 156**  
**Newcastle upon Tyne NE1 6SU (GB)**

(56) References cited:  
**EP-A- 0 872 210 WO-A-03/003914**  
**WO-A-03/092490 US-A- 5 924 979**

**EP 1 741 384 B1**

Note: Within nine months of the publication of the mention of the grant of the European patent in the European Patent Bulletin, any person may give notice to the European Patent Office of opposition to that patent, in accordance with the Implementing Regulations. Notice of opposition shall not be deemed to have been filed until the opposition fee has been paid. (Art. 99(1) European Patent Convention).

**Description**

FIELD OF THE INVENTION

5 **[0001]** The present invention relates to power conservation in portable medical devices, and in particular to power conservation in portable medical devices which use light emitting devices.

BACKGROUND OF THE INVENTION

10 **[0002]** Recent trends in miniaturization of medical devices, in particular the design and implementation of patient monitors as portable units, have created the need to maximize power conservation in order to reduce the required size of the attached battery. Standalone pulse oximetry systems have generally not attempted to conserve power because either the continuous AC power is available or a sizable battery is attached. Present monitoring needs, however, demand smaller profile, higher computational capacity for advanced algorithmic processing, integration with monitoring capability for other medical parameters, and also portability. In general, therefore, it is desirable to minimize power consumption. Power conservation in the pulse oximetry system, in particular, can yield additional running time for other medical parameter monitors in a multi-parameter patient monitor running on batteries.

15 **[0003]** In a typical pulse oximetry system, as much as 50% of power is used for driving the light emitting diodes (LEDs). Therefore, minimizing the power consumption of the LEDs enhances the lifetime of a battery after a full charge. In addition, advances in accurate calculation of blood oxygen level and pulse rate by pulse oximetry systems are due to the development of sophisticated algorithms and the integration of high capacity data processors capable of performing these algorithms into pulse oximetry systems. Such high capacity processors can also consume a significant amount of power. Minimizing the power consumption of the data processor can also enhance the lifetime of a battery after a full charge. A system according to invention principles addresses these needs and associated problems.

20 **[0004]** US 5,924,979 discloses a method and apparatus for conserving power in a medical diagnostic apparatus by using a sleep mode. The sleep mode allows not only the processor to be put to sleep, but other detection circuitry as well. This is accomplished by not relying on detecting events to awaken the sleeping circuitry, but rather establishing the stability of a physiological parameter before going to sleep. The apparatus is periodically awakened from the sleep mode to take additional measurements and to ascertain that the stability of the physiological parameter has not changed.

30 BRIEF SUMMARY OF THE INVENTION

**[0005]** In accordance with principles of the present invention, a system for adjusting power employed by a medical device incorporating light emitting devices and being used for measuring patient medical parameters, includes a plurality of light emitting devices. A power unit is coupled to the light emitting devices and powers the light emitting devices responsive to respective control signals which determine power to be applied to the light emitting devices. A control unit provides the control signals and is coupled to the power unit. The control signals intermittently turn off at least one of the plurality of light emitting devices in a power save mode in response to a determination that a patient medical parameter value measured by the medical device, using an active light emitting device of the plurality of light emitting devices, is at a safe level.

40 **[0006]** According to an aspect of the present invention, there is provided a system for adjusting power employed by a medical device incorporating light emitting devices and being used for measuring patient medical parameters, comprising:

- 45 a plurality of light emitting devices;
- a power unit coupled to said light emitting devices for powering said light emitting devices responsive to respective control signals for determining power applied to said light emitting devices; and
- a control unit for providing said control signals and being coupled to the power unit, said control signals intermittently turning off at least one of said plurality of light emitting devices in a power save mode in response to a determination
- 50 that a patient medical parameter value measured by said medical device, using an active light emitting device of said plurality of light emitting devices, is at a safe level;

**characterised in that**, in said power save mode, at least one of said plurality of light emitting devices is maintained in an active state.

55 **[0007]** In a preferred embodiment, said control unit determines a patient medical parameter value comprising a blood oxygen saturation representative value is at said safe level by being above a predetermined threshold.

**[0008]** In a preferred embodiment, said control unit determines a patient medical parameter value comprising a pulse rate is at said safe level by being within a predetermined range.

**[0009]** The patient medical parameter may comprise at least one of:

- a blood oxygen saturation representative parameter;
- a change in a blood oxygen saturation representative parameter;
- 5 a rate-of-change of a blood oxygen saturation representative parameter;
- a pulse rate;
- a change in pulse rate;
- patient temperature;
- arterial blood pressure;
- 10 a hematocrit level; and
- a cardiac index.

**[0010]** In a preferred embodiment, said control signals intermittently turn off at least first and second different light emitting devices of said plurality of light emitting devices, and said medical device stores a parameter value obtained using an active first light emitting device prior to turning off said active light emitting device.

**[0011]** In a preferred embodiment, said control unit uses said stored parameter value obtained using said first light emitting device together with a parameter value obtained using an active second light emitting device to determine said patient medical parameter value measured by said medical device is at a safe level.

**[0012]** The system may further comprise:

- a data processor employing a plurality of different processing functions for processing data derived using said plurality of light emitting devices in determining said patient medical parameter value measured by said medical device; wherein:

said control unit provides a control signal for turning off at least one processing function of said plurality of processing functions in said power save mode in response to a sensitivity determination, said sensitivity determination being used to turn off a function having least effect in said determination of said patient medical parameter value measured by said medical device.

**[0013]** The control unit may provide control signals for progressively turning off processing functions of said plurality of processing functions in said power save mode in response to sensitivity determinations.

**[0014]** In a preferred embodiment, a subset of the plurality of processing functions operates in the frequency domain; the system further comprises a fast Fourier transform (FFT) processing function, for transforming a set of time domain input samples, representing respective signals from said plurality of light emitting devices, into a corresponding set of frequency domain samples; and said control unit provides control signals for reducing the processing required to produce said frequency domain samples in said power save mode.

**[0015]** The number of samples in the set of time domain samples may be reduced in said power save mode.

**[0016]** The rate at which successive sets of time domain samples are transformed into corresponding sets of frequency domain output samples may be reduced in said power save mode.

**[0017]** The control unit may provide a control signal for turning off said at least one of said plurality of light emitting devices in a power save mode for a user configurable predetermined time duration and monitor a patient medical parameter that is measured without using said at least one of said plurality of light emitting devices; and

in response to a determination said monitored patient medical parameter value is outside a predetermined range, said control unit may terminate said power save mode and turn on said at least one of said plurality of light emitting devices.

**[0018]** In a preferred embodiment, at least one of said control signals turns off at least one of said plurality of light emitting devices in a power save mode for a predetermined time duration, and said control unit

monitors a patient medical parameter that is measured without using said at least one light emitting device, and in response to a determination said monitored patient medical parameter value is outside a predetermined range, terminates said power save mode and turns on said plurality of light emitting devices.

**[0019]** The control unit may provide a control signal turning off operation of medical device functions unused in deriving said patient medical parameter that is measured without using said at least one light emitting device.

**[0020]** The system may further comprise:

- a data processor employing a plurality of different processing functions for processing data derived using at least one of said plurality of light emitting devices in determining a patient medical parameter value measured by said

medical device; wherein:

5 said control unit provides a control signal for turning off at least one processing function of said plurality of processing functions in a power save mode in response to a sensitivity determination, said sensitivity determination being used to turn off a function having least effect in said determination of said patient medical parameter value measured by said medical device.

**[0021]** The monitored patient medical parameter value may comprise at least one of:

10 a heart rate related parameter value;  
a rate-of-change of a blood oxygen representative parameter;  
patient temperature;  
arterial blood pressure;  
a hematocrit level, and  
15 a cardiac index.

**[0022]** The predetermined time duration may be user configurable.

**[0023]** The predetermined time duration may be adjustable by said system.

**[0024]** In a preferred embodiment, said control unit

20 provides a control signal for turning off processing of data occurring in deriving a patient medical parameter using at least one of said light emitting devices in said power save mode.

**[0025]** The patient medical parameter derived using said light emitting device may comprise at least one of, (a) a blood oxygen saturation representative parameter and (b) a pulse rate.

**[0026]** The system may further comprise

25 a data processor employing a plurality of different processing functions for processing data derived using at least one of said light emitting devices in determining a patient medical parameter value measured by said medical device; wherein said control unit further provides a control signal for turning off at least one processing function of said plurality of processing functions in a power save mode in response to a predetermined function disablement procedure.

30 **[0027]** In a preferred embodiment, said predetermined function disablement procedure turns off said at least one processing function in response to a sensitivity determination, said sensitivity determination being used to turn off a function having least effect in said determination of said patient medical parameter value measured by said medical device.

**[0028]** The control unit may provide control signals for progressively turning off processing functions of said plurality of processing functions in said power save mode in response to sensitivity determinations.

35 **[0029]** In a preferred embodiment, said control unit provides control signals for intermittently turning off said plurality of light emitting devices in a power save mode in response to a determination a patient medical parameter value measured by said medical device, using an active light emitting device of said plurality of light emitting devices, is at a safe level.

**[0030]** In a preferred embodiment,

40 a first control signal turns off at least one of said light emitting devices in a power save mode for a user configurable predetermined time duration; and

said control unit monitors a patient medical parameter that is measured without using at least one of said light emitting devices and in response to a determination said monitored patient medical parameter value is outside a predetermined range, terminates said power save mode and turns on said light emitting device.

45 **[0031]** In a preferred embodiment, at least one of said light emitting devices is used in monitoring a first parameter comprising a blood oxygen related patient parameter; and said control unit

provides a control signal for initiating switching off said at least one light emitting device for a predetermined time duration in a power save mode, and

50 in response to a determination that a monitored second parameter has a value outside a predetermined range, said monitored second parameter comprising a patient medical parameter that is measured without using said at least one light emitting device, switching on said light emitting device.

**[0032]** In a preferred embodiment,

said control unit

55 monitors a patient medical parameter that is measured without using said at least one of said light emitting devices, and in response to a determination said monitored patient medical parameter value is outside a predetermined range, turns on said at least one of said light emitting devices.

**[0033]** In a preferred embodiment, said control unit provides a control signal turning off at least one processing function of a plurality of processing functions in response to a sensitivity determination, said sensitivity determination being used to turn off a function having least effect in said determination of said patient medical parameter value measured by said

medical device.

#### BRIEF DESCRIPTION OF THE DRAWING

5 **[0034]** In the drawing:

Fig. 1 is a block diagram of a system according to principles of the present invention;

10 Fig. 2 is a flow chart illustrating the process of entering and terminating a power save mode in the system of Fig. 1 according to the present invention; and

Fig. 3 is a block diagram illustrating a portion of the processing which is performed in a data processor according to the present invention.

#### 15 DETAILED DESCRIPTION OF THE INVENTION

**[0035]** A processor, as used herein, operates under the control of an executable application to (a) receive information from an input information device, (b) process the information by manipulating, analyzing, modifying, converting and/or transmitting the information, and/or (c) route the information to an output information device. A processor may use, or comprise the capabilities of, a controller or microprocessor, for example. The processor may operate with a display processor or generator. A display processor or generator is a known element for generating signals representing display images or portions thereof. A processor and a display processor comprises any combination of, hardware, firmware, and/or software.

25 **[0036]** An executable application, as used herein, comprises code or machine readable instructions for conditioning the processor to implement predetermined functions, such as those of an operating system, medical device system or other information processing system, for example, in response to user command or input. An executable procedure is a segment of code or machine readable instruction, sub-routine, or other distinct section of code or portion of an executable application for performing one or more particular processes. These processes may include receiving input data and/or parameters, performing operations on received input data and/or performing functions in response to received input parameters, and providing resulting output data and/or parameters.

30 **[0037]** Fig. 1 illustrates a portion of a medical device, incorporating light emitting devices, used to measure patient medical parameters. Fig. 1 is a block diagram of a system 1 employed by such a medical device for adjusting power employed by the medical device. In system 1, a plurality 10 of light emitting devices 12, 14 produce respective light signals 15. The light signals 15 are passed through, or reflected off of, biological tissue 20. The resulting respective light signals 25, modified by passing through or being reflected off of the biological tissue 20, are received by a corresponding plurality 30 of light sensor devices 32, 34. The plurality 30 of light sensor devices 32, 34 convert the received light signals 25 into corresponding electrical signals 35. Respective output terminals of the plurality 30 of light sensor devices 32, 34 are coupled to corresponding input terminals of a data processor 40. A signal output terminal of the data processor 40 generates a medical parameter, and data processor 40 provides a further signal coupled to an input terminal of a control unit 50. A control output terminal of the data processor 40 is coupled to an input terminal of a parameter value store 42. An output terminal of the parameter value store 42 is coupled to a second input terminal of the control unit 50. Respective output terminals of the control unit 50 generates control signals, and are coupled to corresponding control input terminals of a power unit 60. Respective output terminals of the power unit 60 are coupled to corresponding input terminals of the plurality 10 of light emitting devices 12, 14. A control output terminal of the control unit 50 is coupled to a control input terminal of the data processor 40. An input terminal 55 is coupled to a source (not shown) of a control signal. The input terminal 55 is coupled to a control input terminal of the control unit 50.

45 **[0038]** In operation, the power unit 60 powers the plurality 10 of light emitting devices 12, 14, responsive to the respective control signals. The control signals determine the power applied to the plurality 10 of light emitting devices 12, 14. The control unit 50, coupled to the power unit 60, provides the control signals. The control signals condition the power unit 60 to intermittently turn off at least one of the plurality 10 of light emitting devices 12, 14 in a power save mode. The control unit 50 initiates the power save mode in response to a determination that a patient medical parameter value measured by the medical device using an active light emitting device of the plurality of light emitting devices, is at a safe level.

55 **[0039]** For example, the system 1 may be implemented in a pulse oximeter medical device. A pulse oximeter produces successive blood oxygen saturation (e.g. SpO<sub>2</sub>) and/or pulse rate (e.g. PLS) readings as the patient medical parameter values. In a pulse oximeter, the light emitting devices 10 are typically light emitting diodes (LEDs). The first LED 12 emits red light and the second LED 14 emits infrared (IR) light. They are typically time multiplexed to produce light signals 15 one at a time to produce a single SpO<sub>2</sub> and/or pulse rate reading. Respective signals 35 from the red 12 and IR 14 light

sensors 32, 34 are read by the data processor 40 when the corresponding LED is on. The data processor 40 then processes those signals to calculate an  $\text{SpO}_2$  and/or the pulse rate reading. Intermediate components are also typically calculated. For example, ac and dc components of the respective red and IR LED signals 35 are calculated and stored, and those components used to calculate the  $\text{SpO}_2$  and/or pulse rate medical parameter.

**[0040]** In a pulse oximeter medical device, the system 1 enters a power save mode (described in more detail below) when a patient medical parameter value is at a safe level. The patient medical parameter value may be one measured by the medical device itself. For example, the patient medical parameter value may be the blood oxygen saturation representative value. The control unit 50 determines that the patient medical parameter value (e.g. the blood oxygen saturation representative value) is at a safe level when it is above a predetermined threshold, for example. The patient medical parameter value may also be the pulse rate. The control unit 50 determines that the patient medical parameter value (e.g. the pulse rate) is at a safe level when it is within a predetermined range.

**[0041]** Similarly, the patient medical parameter value may indicate a change in the blood oxygen saturation representative value or a change in the pulse rate. The control unit 50 also determines that the patient medical parameter value (e.g. the change in blood oxygen saturation representative value or pulse rate) is at a safe level when it is less than a predetermined value. The patient medical parameter value may also be a rate-of-change of the blood oxygen saturation representative parameter or pulse rate. The control unit 50 further determines that the patient medical parameter value (e.g. rate-of-change of the blood oxygen saturation value or rate-of-change of the pulse rate) is at a safe level when it is within a predetermined range.

**[0042]** It is also possible for the patient medical parameter value which controls entry to the power save mode to be provided from an external source, such as a separate patient monitoring device measuring other patient medical parameters. The patient medical parameter value may also be entered manually. An output terminal of such an external patient monitoring device (not shown) and/or manual input device (also not shown) may be coupled to the control unit 50 via the external terminal 55. The patient medical parameter value, in such a case, may be at least one of: patient temperature; arterial blood pressure; a hematocrit level; and/or a cardiac index. One or more of the patient medical parameter values described above, and/or any other similar patient medical parameter value, may be used by the control unit 50 to determine if the patient medical parameter value is at a safe level.

**[0043]** In the illustrated pulse oximeter embodiment, the patient medical parameter value is determined to be at a safe level when the  $\text{SpO}_2$  and pulse rate parameters are stable and within a predetermined range of acceptable values. This is illustrated in Fig. 2 which illustrates the process of entering and terminating the power save mode in the system illustrated in Fig. 1. For example, in an adult, the  $\text{SpO}_2$  reading should be between 90% and 100% and the pulse rate should be between 50 and 100 beats per minute (bpm). Stability is determined by the change and the rate-of-change in the  $\text{SpO}_2$  and pulse rate values being less than a relatively low threshold. The acceptable range of  $\text{SpO}_2$  and pulse rate values, and threshold levels for the change in these values may be adjusted by a user. The control unit 50 receives the  $\text{SpO}_2$  and pulse rate values from the data processor 40, and calculates the change in those values and the rate-of-change of those values.

**[0044]** More specifically, in the illustrated embodiment, both LEDs 12 and 14 are enabled in step 202. In step 204 values for  $\text{SpO}_2$  and pulse rate (PLS) medical parameters are calculated by the data processor 40 based on the signals 35 representing the received light from the LEDs 12, 14. In block 205, patient stability is determined. In step 206 the pulse rate value PLS is compared to low and high thresholds  $P_L$  and  $P_H$ , respectively, and the  $\text{SpO}_2$  value is compared to low and high thresholds,  $S_L$  and  $S_H$ , respectively. If the PLS value is between  $P_L$  and  $P_H$  and the  $\text{SpO}_2$  value is between  $S_L$  and  $S_H$ , then step 208 is performed, otherwise, the medical device remains in normal mode and operation returns to step 202. In step 208 the change in the PLS value ( $\Delta\text{PLS}$ ) is compared to a thresholds  $\Delta P$ , and the change in the  $\text{SpO}_2$  value ( $\Delta\text{SpO}_2$ ) is compared to a threshold  $\Delta S$ . If the  $\Delta\text{PLS}$  value is less than the  $\Delta P$  threshold, and the  $\Delta\text{SpO}_2$  value is less than the  $\Delta S$  threshold, then step 210 is performed, otherwise, the medical device remains in normal mode and operation returns to step 202. In step 210 the rate-of-change of the PLS value (ROC PLS) is compared to a thresholds  $_{\min}P_{\text{ROC}}$ , and the rate-of-change in the  $\text{SpO}_2$  value (ROC  $\text{SpO}_2$ ) is compared to a threshold  $_{\min}S_{\text{ROC}}$ . If the ROC  $\text{SpO}_2$  value is less than the  $_{\min}S_{\text{ROC}}$  threshold, and the ROC PLS value is less than the  $_{\min}P_{\text{ROC}}$  threshold, then step 210 is performed, otherwise, the medical device remains in normal mode and operation returns to step 202.

**[0045]** In addition to checking the medical parameter to determine if the patient is safe and stable, it is also possible to check other signal parameters to determine whether the patient and the system are in condition to operate in a power save mode. In Fig. 2, a check is made on the consistency of the signals 35, representing the light received from the plurality 10 of LEDs 12 and 14. Signal consistency may be represented by the signal-to-noise ratio of the received signal, by drift of signal components, such as an ac and/or dc component, or any other similar measure of signal consistency.

**[0046]** In block 211, signal consistency is determined. In step 212 the signal consistency of the signal 35 ( $\text{SC}_{\text{RED}}$ ) representing the light received from the red LED 12 is compared to a threshold  $_{\min}\text{SC}_{\text{RED}}$ . If the signal consistency of the red signal  $\text{SC}_{\text{RED}}$  is greater than the threshold  $_{\min}\text{SC}_{\text{RED}}$ , then step 214 is performed, otherwise, the medical device remains in normal mode and operation returns to step 202. Similarly, in step 212 the signal consistency of the signal 35 ( $\text{SC}_{\text{IR}}$ ) representing the light received from the IR LED 14 is compared to a threshold  $_{\min}\text{SC}_{\text{IR}}$ . If the signal consistency

of the IR signal  $SC_{IR}$  is greater than the threshold  $_{min}SC_{IR}$ , then the patient is considered to be stable and the signals consistent. In this case, the system 1 (Fig. 1) enters the power save mode and step 222 is performed, otherwise, the medical device remains in normal mode and operation returns to step 202.

**[0047]** In one embodiment, the control unit 50 (Fig. 1) provides control signals to the power unit 60 conditioning it to intermittently turn off at least first and second different LEDs 12, 14 of the plurality 10 of LEDs 12, 14 in the power save mode. Referring again to Fig. 2, in step 222, one of the plurality 10 of LEDs is turned off. In this mode, when one LED (e.g. 12) is turned off, the other LED (e.g. 14) remains active. Prior to turning off an LED (e.g. 12), parameter values obtained using the active LED are stored in the parameter value store 42. In step 224, the parameter values for the LED to be turned off are stored, and a reading is taken using the other, active, LED.

**[0048]** More specifically, in the illustrated embodiment, parameter values resulting from e.g. intermediate calculations made by the data processor 40 (Fig. 1) related to the IR LED (e.g. 14) are stored in the parameter value store 42. When that LED (e.g. 14) is turned off, the stored parameter values are retrieved from the parameter value store 42 and used together with the parameter values obtained using the active LED (e.g. the IR LED 14) to calculate the medical parameter, e.g.  $SpO_2$  and/or pulse rate. The calculation of the medical parameter, i.e.  $SpO_2$  and/or pulse rate, are performed in step 224. In addition, the control unit 50 retrieves the stored parameter value from the parameter value store 42, and uses the stored parameter values obtained using the previously active LED (e.g. 14) together with a parameter values obtained using the active LED (e.g. 12) to determine that the patient medical parameter value measured by the medical device is remaining at a safe level while in the power save mode.

**[0049]** As described above, in the illustrated embodiment, the patient medical parameter value is considered at a safe level if the patient remains stable and the signal remains consistent. Block 225 checks signal consistency. In step 226 the change in the dc level  $\Delta DC$  of the active LED (e.g. 14) signal 35 is compared to a threshold  $\Delta DC_{min}$ . If  $\Delta DC$  is less than the threshold  $\Delta DC_{min}$  then step 228 is activated. Otherwise, it is determined that the signal is not consistent and the power save mode is terminated by returning to step 202 where both LEDs are activated. In step 228 the change in the ac level  $\Delta AC$  of the active LED (e.g. 14) signal 35 is compared to a threshold  $\Delta AC_{min}$ . If  $\Delta AC$  is less than the threshold  $\Delta AC_{min}$  then step 230 is activated. Otherwise, it is determined that the signal is not consistent and the power save mode is terminated by returning to step 202 where both LEDs are activated.

**[0050]** In block 235, patient stability is checked. In step 230, the change in the  $SpO_2$  parameter  $\Delta SpO_2$  is compared to a threshold. In the illustrated embodiment, the threshold is 1%. If the change in the  $SpO_2$  parameter  $\Delta SpO_2$  is less than 1%, then step 232 is activated. Otherwise, it is determined that the patient is not stable and the power save mode is terminated by returning to step 202 where both LEDs are activated. In step 232, the change in the pulse rate parameter  $\Delta PLS$  is compared to a threshold. In the illustrated embodiment, the threshold is also 1%. If the change in the PLS parameter  $\Delta PLS$  is less than 1%, then it is determined that the patient remains stable and the signal remains consistent. In this case, the system remains in the power save mode by returning to step 222. Otherwise, it is determined that the patient is not stable and the power save mode is terminated by returning to step 202 where both LEDs are activated.

**[0051]** One skilled in the art understands that turning off one LED (e.g. 14) and using stored parameters representing the signals received when that LED was last active to calculate the medical parameter, i.e.  $SpO_2$  and/or pulse rate, some inaccuracy may enter into the medical parameter value. However, because the power save mode is entered when the patient is stable, meaning that the medical parameter  $SpO_2$  and/or pulse rate is relatively unchanging, the inaccuracy is relatively small, and is a reasonable trade off compared to the power savings entailed by turning off one LED.

**[0052]** In the embodiment illustrated in Fig. 2, the system remains in the power save mode for as long as the patient remains stable and the signals remain consistent. Alternatively, at some point in time, which may be a predetermined time duration, a predetermined number of heart beats, a predetermined number of readings of the medical parameter measured by the medical device, or a time period determined in any other similar manner, the system automatically terminates the power save mode, and returns to the normal mode. This may be done to reset the stored parameters for the LED which was turned off. The predetermined time duration may be user configurable

**[0053]** Also as described above, an external patient monitor may supply patient medical parameters to the control unit 50 via the external terminal 55. The control unit 50 monitors the patient medical parameters from the external patient monitor, i.e. the medical parameters that are measured without using at least one of the plurality 10 of light emitting devices 12, 14. In response to a determination that the externally monitored patient medical parameter value is outside a predetermined range, the control unit 50 terminates the power save mode and turns on the light emitting device (e.g. 14) of the plurality of light emitting devices which was previously turned off.

**[0054]** As described above, power is also employed by the data processor 40 (Fig. 1) in performing the processing necessary to derive the patient medical parameter, e.g.  $SpO_2$  and/or pulse rate, from the signals 35 representing the received light signals 25. Fig. 3 is a block diagram illustrating a portion of the processing which is performed in the data processor 40 according to the present invention. In Fig. 3, the light representative signals 35 are coupled to respective signal input terminals of time domain processes 302 and to a signal input terminal of an FFT process 304. An output terminal of the FFT process 304 is coupled to respective signal input terminals of frequency domain processes 306.

**[0055]** More specifically, in the illustrated embodiment, a plurality of N time domain processes, TD PROC 1, TD PROC

2, ... TD PROC N, are illustrated. The light representative signals 35 are coupled to respective signal input terminals of the plurality 302 of time domain processes, TD PROC 1, TD PROC 2, ... TD PROC N. Similarly, a plurality of N frequency domain processes, FD PROC 1, FD PROC 2, ... FD PROC N, are illustrated. The output terminal of the FFT process 304 is coupled to respective signal input terminals of the plurality 306 of frequency domain processes 306, FD PROC 1, FD PROC 2, ... FD PROC N.

**[0056]** The control signal from the control unit 50 (Fig. 1) to the data processor 40 is coupled to an input terminal of a control process 310. Respective output terminals of the control process 310 are coupled to corresponding control input terminals of the plurality 302 of time domain processes, TD PROC 1, TD PROC 2, ... TD PROC N, and the plurality 306 of frequency domain processes, FD PROC 1, FD PROC 2, ... FD PROC N. Respective control output terminals of the controller 310 are also coupled to corresponding control input terminals of the FFT process 304 and the sensitivity selector 308.

**[0057]** In operation, the data processor 40 employs a plurality of different processing functions (TD PROC 1, TD PROC 2, ... TD PROC N; FD PROC 1, FD PROC 2, ... FD PROC N) for processing the data in the signals 35 (Fig. 1) derived using the plurality 10 of light emitting devices 12, 14 in determining the patient medical parameter value, e.g. SpO<sub>2</sub>, pulse rate, measured by the medical device. A subset 302 of the plurality of processing functions operate in the time domain. Another subset 304 of the plurality of processing functions operate in the frequency domain. The control unit 50 provides a control signal to the control process 310 in the data processor 40 for turning off at least one processing function of the plurality of processing functions (TD PROC 1, TD PROC 2, ... TD PROC N; FD PROC 1, FD PROC 2, ... FD PROC N) in the power save mode in response to a predetermined function disablement procedure, described in more detail below. As described above, the power save mode may be initiated in response to a determination that the patient medical parameter (e.g. SpO<sub>2</sub>, pulse rate), measured by the medical device using the active light emitting device (e.g. 14) of the plurality 10 of light emitting devices 12, 14, is at a safe level. More specifically, in the illustrated embodiment, the power save mode is initiated in step 222 of Fig. 2.

**[0058]** In the illustrated embodiment, the predetermined function disablement procedure turns off at least one processing function (TD PROC 1, TD PROC 2, ... TD PROC N; FD PROC 1, FD PROC 2, ... FD PROC N) in response to a sensitivity determination. The sensitivity determination is used to turn off the function (TD PROC 1, TD PROC 2, ... TD PROC N; FD PROC 1, FD PROC 2, ... FD PROC N) having least effect in the determination of the patient medical parameter value (e.g. SpO<sub>2</sub>, pulse rate) measured by the medical device. In an alternative embodiment, the control unit 50 provides control signals 40 to the control process 310 for progressively turning off processing functions of the plurality of processing functions (TD PROC 1, TD PROC 2, ... TD PROC N; FD PROC 1, FD PROC 2, ... FD PROC N) in the power save mode in response to the sensitivity determinations.

**[0059]** In the illustrated embodiment, the sensitivity selector 310 operates as probability-based classifier. Such a selector 310 classifies the results from the plurality of processing functions (TD PROC 1, TD PROC 2, ... TD PROC N; FD PROC 1, FD PROC 2, ... FD PROC N), termed features, based on the calculated probability, termed sensitivity, of their being accurate estimates of the patient medical parameter, e.g. SpO<sub>2</sub>, pulse rate. With such a selector, the number of features (TD PROC 1, TD PROC 2, ... TD PROC N; FD PROC 1, FD PROC 2, ... FD PROC N) used for the classifier computation may be reduced without compromising performance. The decision to select a particular feature (TD PROC 1, TD PROC 2, ... TD PROC N; FD PROC 1, FD PROC 2, ... FD PROC N) to turn off is based on the sensitivity of that feature. During a typical computing iteration, multiple possible outcomes (e.g. SpO<sub>2</sub> readings and/or pulse rate frequencies) are considered concurrently by the feature processes (TD PROC 1, TD PROC 2, ... TD PROC N; FD PROC 1, FD PROC 2, ... FD PROC N). A feature process (TD PROC 1, TD PROC 2, ... TD PROC N; FD PROC 1, FD PROC 2, ... FD PROC N) assigns a probability value to the possible outcomes. The power of classification is computed for an individual feature process (TD PROC 1, TD PROC 2, ... TD PROC N; FD PROC 1, FD PROC 2, ... FD PROC N) to assess its sensitivity level S. For example, for a feature process (TD PROC 1, TD PROC 2, ... TD PROC N; FD PROC 1, FD PROC 2, ... FD PROC N) with n possible outcomes, the sensitivity S is computed by comparing the respective probabilities P<sub>n</sub> of an outcome to the probability of the last reported outcome P' where:

$$S = \frac{1}{N} \sum_{n=1}^N (P' - P_n) \quad (\text{Equ 1})$$

**[0060]** The process (TD PROC 1, TD PROC 2, ... TD PROC N; FD PROC 1, FD PROC 2, ... FD PROC N) with the lowest sensitivity level S is turned off and consequently not processed by the sensitivity selector 308. In an alternate embodiment, processes (TD PROC 1, TD PROC 2, ... TD PROC N; FD PROC 1, FD PROC 2, ... FD PROC N) having the lowest sensitivity level S are progressively turned off. With fewer processes operating, power consumption by the data processor 40 is reduced.

**[0061]** It is further possible to control the FFT process 304 to reduce the processing required, and therefore, the power

consumption. One skilled in the art understands that an FFT process transforms a set of time domain input samples, representing the respective signals 35 from the plurality 10 of light emitting devices 12, 14, into a corresponding set of frequency domain output samples. The control unit 50 (Fig. 1) provides a control signal to the control process 310 in the data processor 40 which conditions the FFT process 304 to reduce the processing required to produce the frequency domain samples in the power save mode. Specifically, the number of samples in the input and output sample set, and the rate at which conversion cycles are made may be controlled. In the power save mode, the number of samples in the set of time domain samples (and corresponding frequency domain output samples) is reduced and/or the rate at which successive sets of time domain input samples are transformed into corresponding sets of frequency domain samples is reduced. Less power is consumed when fewer samples are transformed, and when the rate of conversion cycles is reduced.

**[0062]** In the illustrated embodiment, the processing blocks in Fig. 3 (e.g. TD PROC 1, TD PROC 2, ... TD PROC N; FD PROC 1, FD PROC 2, ... FD PROC N, 304, 308, 310) represent executable procedures which may be executed by the data processor 40. One skilled in the art understands that these processing blocks may be implemented in hardware, firmware, software or any combination of the three.

**[0063]** It is also possible that a medical device, such as a pulse oximeter medical device, may be one component in a multifunction patient monitor device. For example, a multifunction patient monitor device may include an ECG monitor, blood pressure monitor, temperature monitor, ventilation monitor, etc. in addition to the pulse oximeter monitor providing SpO<sub>2</sub> and pulse rate medical parameters. In such a multifunction medical device, it is possible to provide further power savings by turning off operation of the pulse oximeter functions completely. More specifically, in the illustrated embodiment, the pulse oximeter system uses the plurality 10 (Fig. 1) of light emitting devices 12, 14 to derive the SpO<sub>2</sub> and pulse rate patient medical parameters. However, the other medical devices in the multifunction monitor derive patient medical parameters (i.e. ECG lead signals, blood pressure, temperature, ventilation parameters, etc.) without using the plurality 10 of light emitting devices 12, 14.

**[0064]** In such a monitor, the control unit 50 (Fig. 1) may provide a control signal coupled to the power unit 60 for turning off the light emitting device in a power save mode for a predetermined time duration. The control unit 50 may further provide a control signal for turning off processing of data occurring in deriving the patient medical parameter (e.g. SpO<sub>2</sub>, pulse rate) using the light emitting device. The control unit 50 (Fig. 1) may instead provide a control signal turning off operation of the medical device functions which are unused in deriving the patient medical parameter (e.g. SpO<sub>2</sub>, pulse rate) that is measured without using the light emitting devices 12, 14 in response to a determination that the patient medical parameter value measured by the medical device using an active light emitting device (e.g. 14) of the plurality 10 of light emitting devices 12, 14 (e.g. SpO<sub>2</sub>, pulse rate), is at a safe level. The control unit 50 then monitors a patient medical parameter that is measured without using the light emitting devices 12, 14 (e.g. EKG, temperature, ventilation parameters, etc.) and in response to a determination that the monitored patient medical parameter value is outside of a predetermined range, terminates the power save mode and turns on the light emitting devices 12, 14 and the processing of data. In this manner, the power consumed by the pulse oximeter monitor may be eliminated or substantially reduced.

**[0065]** It will be appreciated by persons skilled in the art that the above embodiment has been described by way of example only, and not in any limitative sense, and that various alterations and modifications are possible without departure from the scope of the invention as defined by the appended claims.

## Claims

1. A system (1) for adjusting power employed by a medical device incorporating light emitting devices and being used for measuring patient medical parameters, comprising:

a plurality (10) of light emitting devices (12, 14);  
 a power unit (60) coupled to said light emitting devices (12, 14) for powering said light emitting devices (12, 14) responsive to respective control signals for determining power applied to said light emitting devices (12, 14); and  
 a control unit (50) for providing said control signals and being coupled to the power unit (60), said control signals intermittently turning off at least one of said plurality (10) of light emitting devices (12, 14) in a power save mode in response to a determination that a patient medical parameter value measured by said medical device, using an active light emitting device (12, 14) of said plurality (10) of light emitting devices (12, 14), is at a safe level;

**characterised in that**, in said power save mode, at least one of said plurality of light emitting devices is maintained in an active state.

2. The system (1) according to claim 1, wherein said control unit (50) determines a patient medical parameter value comprising a blood oxygen saturation representative value is at said safe level by being above a predetermined

threshold.

3. The system (1) according to claim 1 or 2, wherein said control unit (50) determines a patient medical parameter value comprising a pulse rate is at said safe level by being within a predetermined range.

5

4. The system (1) according to any one of the preceding claims, wherein said patient medical parameter comprises at least one of:

10

- a blood oxygen saturation representative parameter;
- a change in a blood oxygen saturation representative parameter;
- a rate-of-change of a blood oxygen saturation representative parameter;
- a pulse rate;
- a change in pulse rate;
- patient temperature;
- arterial blood pressure;
- a hematocrit level; and
- a cardiac index.

15

20

5. A system (1) according to any one of the preceding claims, wherein said control signals intermittently turn off at least first (12) and second (14) different light emitting devices of said plurality (10) of light emitting devices and:

said medical device stores a parameter value (42) obtained using an active first light emitting device (12) prior to turning off said active light emitting device (12).

25

6. The system (1) according to claim 5, wherein said control unit (50) uses said stored parameter value (42) obtained using said first light emitting device (12) together with a parameter value obtained using an active second light emitting device (14) to determine said patient medical parameter value measured by said medical device is at a safe level.

30

7. The system (1) according to claim 5 or 6, further comprising:

a data processor (40) employing a plurality (10) of different processing functions for processing data derived using said plurality (10) of light emitting devices (12, 14) in determining said patient medical parameter value measured by said medical device;

35

wherein:

said control unit (50) provides a control signal for turning off at least one processing function of said plurality of processing functions in said power save mode in response to a sensitivity determination (308), said sensitivity determination (308) being used to turn off a function having least effect in said determination of said patient medical parameter value measured by said medical device.

40

8. The system (1) according to claim 7, wherein said control unit (50) provides control signals for progressively turning off processing functions of said plurality of processing functions in said power save mode in response to sensitivity determinations (308).

45

9. The system (1) according to claim 7 or 8, wherein a subset of the plurality of processing functions (306) operates in the frequency domain; the system further comprises a fast Fourier transform (FFT) processing function (304), for transforming a set of time domain input samples, representing respective signals (35) from said plurality (10) of light emitting devices (12, 14), into a corresponding set of frequency domain samples; and said control unit (50) provides control signals for reducing the processing required to produce said frequency domain samples in said power save mode.

50

10. The system (1) according to claim 9 wherein the number of samples in the set of time domain samples (35) is reduced in said power save mode.

55

## EP 1 741 384 B1

11. The system (1) according to claim 9 or 10, wherein the rate at which successive sets of time domain samples (35) are transformed into corresponding sets of frequency domain output samples is reduced in said power save mode.
- 5 12. The system (1) according to any one of the preceding claims wherein said control unit (50) provides a control signal for turning off said at least one of said plurality (10) of light emitting devices (12, 14) in a power save mode for a user configurable predetermined time duration and monitors a patient medical parameter that is measured without using said at least one of said plurality (10) of light emitting devices (12, 14); and  
10 in response to a determination said monitored patient medical parameter value is outside a predetermined range, said control unit (50) terminates said power save mode and turns on said at least one of said plurality (10) of light emitting devices (12, 14).
13. The system (1) according to any one of the preceding claims, wherein  
15 at least one of said control signals turns off at least one of said plurality (10) of light emitting devices (12, 14) in a power save mode for a predetermined time duration, and said control unit (50) monitors a patient medical parameter that is measured without using said at least one light emitting device (12, 14), and  
20 in response to a determination that said monitored patient medical parameter value is outside a predetermined range, terminates said power save mode and turns on said plurality of light emitting devices (12, 14).
14. The system (1) according to claim 13, wherein said control unit (50) provides a control signal turning off operation of medical device functions unused in deriving said patient medical parameter that is measured without using said at least one light emitting device (12, 14).
- 25 15. The system (1) according to claim 13 or 14, further comprising:  
a data processor (40) employing a plurality of different processing functions for processing data derived using at least one of said plurality (10) of light emitting devices (12, 14) in determining a patient medical parameter value measured by said medical device;  
30 wherein:  
said control unit (50) provides a control signal for turning off at least one processing function of said plurality of processing functions in a power save mode in response to a sensitivity determination (308), said sensitivity determination (308) being used to turn off a function having least effect in said determination of said patient  
35 medical parameter value measured by said medical device.
16. The system (1) according to any one of claims 13 to 15, wherein:  
40 said monitored patient medical parameter value comprises at least one of:  
a heart rate related parameter value;  
a rate-of-change of a blood oxygen representative parameter;  
patient temperature;  
45 arterial blood pressure;  
a hematocrit level, and  
a cardiac index.
17. The system (1) according to any one of claims 13 to 16, wherein said predetermined time duration is user configurable.  
50
18. The system (1) according to any one of claims 13 to 17, wherein said predetermined time duration is adjustable by said system (1).
19. The system (1) according to any one of claims 13 to 18, wherein said control unit (50) further  
55 provides a control signal for turning off processing of data occurring in deriving a patient medical parameter using at least one of said light emitting devices (12, 14) in said power save mode.
20. The system (1) according to claim 19, wherein said patient medical parameter derived using said light emitting

device comprises at least one of, (a) a blood oxygen saturation representative parameter and (b) a pulse rate.

21. The system (1) according to claim 1, further comprising:

5 a data processor (40) employing a plurality of different processing functions for processing data derived using at least one of said light emitting devices (12, 14) in determining a patient medical parameter value measured by said medical device;

10 wherein said control unit (50) further provides a control signal for turning off at least one processing function of said plurality of processing functions in a power save mode in response to a predetermined function disablement procedure.

15 22. The system (1) according to claim 21, wherein said predetermined function disablement procedure turns off said at least one processing function in response to a sensitivity determination (308), said sensitivity determination (308) being used to turn off a function having least effect in said determination of said patient medical parameter value measured by said medical device.

20 23. The system (1) according to claim 22, wherein said control unit (50) provides control signals for progressively turning off processing functions of said plurality of processing functions in said power save mode in response to sensitivity determinations (308).

25 24. The system (1) according to any one of claims 21 to 23, wherein said control unit (50) provides control signals for intermittently turning off said plurality (10) of light emitting devices (12, 14) in a power save mode in response to a determination a patient medical parameter value measured by said medical device, using an active light emitting device of said plurality (10) of light emitting devices (12, 14), is at a safe level.

30 25. The system (1) according to any one of claims 21 to 24, wherein a first control signal turns off at least one of said light emitting devices (12, 14) in a power save mode for a user configurable predetermined time duration; and said control unit (50) monitors a patient medical parameter that is measured without using at least one of said light emitting devices (12, 14) and in response to a determination said monitored patient medical parameter value is outside a predetermined range, terminates said power save mode and turns on said light emitting devices (12, 14).

35 26. The system (1) according to claim 1, wherein:

40 at least one of said light emitting devices (12, 14) is used in monitoring a first parameter comprising a blood oxygen related patient parameter; and said control unit (50) provides a control signal for initiating switching off said at least one light emitting device for a predetermined time duration in a power save mode, and in response to a determination that a monitored second parameter has a value outside a predetermined range, said monitored second parameter comprising a patient medical parameter that is measured without using said at least one light emitting device, switching on said light emitting device.

45 27. The system (1) according to claim 1, wherein:

50 said power unit (60) turns off processing of data occurring in deriving a patient medical parameter using at least one of said light emitting devices (12, 14); and said control unit (50), monitors a patient medical parameter that is measured without using said at least one of said light emitting devices, and in response to a determination said monitored patient medical parameter value is outside a predetermined range, turns on said at least one of said light emitting devices.

55 28. The system (1) according to any one of claims 21 to 27, wherein said control unit (50) provides a control signal turning off at least one processing function of a plurality of processing functions in response to a sensitivity determination (308), said sensitivity determination (308) being used to turn off a function having least effect in said

determination of said patient medical parameter value measured by said medical device.

**Patentansprüche**

5

1. System (1) zur Einstellung der Energie, die von einem medizinischen Gerät eingesetzt wird, in welches lichtemittierende Geräte integriert sind und das zum Messen von medizinischen Parametern von Patienten verwendet wird, umfassend:

10

mehrere (10) lichtemittierende Geräte (12, 14),  
 eine mit den genannten lichtemittierenden Geräten (12, 14) verbundene Energieversorgungseinheit (60) zum Versorgen der genannten lichtemittierenden Geräte (12, 14) als Reaktion auf jeweilige Steuersignale mit Energie zum Bestimmen der an die genannten lichtemittierenden Geräte (12, 14) angelegten Energie, und  
 eine Steuereinheit (50) zum Anlegen der genannten Steuersignale, die mit der Energieversorgungseinheit (60) verbunden ist, wobei die genannten Steuersignale in einem Energiesparmodus als Reaktion auf eine Bestimmung, dass ein von dem genannten medizinischen Gerät unter Verwendung eines aktiven lichtemittierenden Geräts (12, 14) der genannten mehreren (10) lichtemittierenden Geräte (12, 14) gemessener Wert eines medizinischen Patientenparameters auf einem sicheren Pegel liegt, wenigstens eines der genannten lichtemittierenden Geräte (12, 14) aussetzend ausschalten,

20

**dadurch gekennzeichnet, dass** wenigstens eines der genannten mehreren lichtemittierenden Geräte in dem genannten Energiesparmodus in einem aktiven Zustand gehalten wird.

25

2. System (1) nach Anspruch 1, bei dem die genannte Steuereinheit (50) bestimmt, dass ein Wert eines medizinischen Patientenparameters, der einen für die Blutsauerstoffsättigung repräsentativen Wert umfasst, auf dem genannten sicheren Pegel liegt, da er über einem vorbestimmten Schwellenwert liegt.

30

3. System (1) nach Anspruch 1 oder 2, bei dem die genannte Steuereinheit (50) bestimmt, dass ein Wert eines medizinischen Patientenparameters, der eine Pulszahl umfasst, auf dem genannten sicheren Pegel liegt, da er innerhalb eines vorbestimmte Bereichs liegt.

35

einen für die Blutsauerstoffsättigung repräsentativen Parameter,  
 eine Änderung eines für die Blutsauerstoffsättigung repräsentativen Parameters,  
 eine Änderungsquote eines für die Blutsauerstoffsättigung repräsentativen Parameters,  
 eine Pulszahl,  
 eine Änderung der Pulszahl,  
 Patiententemperatur,  
 arterieller Blutdruck,  
 einen Hämatokritwert und  
 einen Herzindex.

40

45

5. System (1) nach einem der vorhergehenden Ansprüche, bei dem die genannten Steuersignale mindestens ein erstes (12) und ein zweites (14) verschiedenes lichtemittierendes Gerät der genannten mehreren (10) lichtemittierenden Geräte aussetzend ausschalten und das genannte medizinische Gerät einen unter Verwendung eines aktiven ersten lichtemittierenden Geräts (12) erhaltenen Parameterwert (42) speichert, bevor das genannte aktive lichtemittierende Gerät (12) ausgeschaltet wird.

50

6. System (1) nach Anspruch 5, bei dem die genannte Steuereinheit (50) den genannten gespeicherten, unter Verwendung des genannten ersten lichtemittierenden Geräts (12) erhaltenen Parameterwert (42) zusammen mit einem unter Verwendung eines aktiven zweiten lichtemittierenden Geräts (14) erhaltenen Parameterwert verwendet, um zu bestimmen, ob der genannte, von dem genannten medizinischen Gerät gemessene Wert des medizinischen Patientenparameters auf einem sicheren Pegel liegt.

55

7. System (1) nach Anspruch 5 oder 6, ferner umfassend:

einen Datenprozessor (40), der mehrere (10) verschiedene Verarbeitungsfunktionen zum Verarbeiten von unter Verwendung der genannten mehreren (10) lichtemittierenden Geräte (12, 14) abgeleiteten Daten beim Bestimmen des genannten, von dem genannten medizinischen Gerät gemessenen Werts des medizinischen Patientenparameters einsetzt, wobei:

5 die genannte Steuereinheit (50) ein Steuersignal zum Ausschalten wenigstens einer Verarbeitungsfunktion der genannten mehreren Verarbeitungsfunktionen in dem genannten Energiesparmodus als Reaktion auf eine Empfindlichkeitsbestimmung (308) anlegt, wobei die genannte Empfindlichkeitsbestimmung (308) zum Ausschalten einer Funktion verwendet wird, die bei der genannten Bestimmung des genannten, von dem  
10 genannten medizinischen Gerät gemessenen Werts des medizinischen Patientenparameters die geringste Wirkung hat.

8. System (1) nach Anspruch 7, bei dem die genannte Steuereinheit (50) Steuersignale zum fortschreitenden Ausschalten von Verarbeitungsfunktionen der genannten mehreren Verarbeitungsfunktionen in dem genannten Energiesparmodus als Reaktion auf Empfindlichkeitsbestimmungen (308) anlegt.  
15

9. System (1) nach Anspruch 7 oder 8, bei dem eine Teilmenge der mehreren Verarbeitungsfunktionen (306) im Frequenzbereich operiert, das System ferner eine schnelle Fourier-Transformation-(FFT)-Verarbeitungsfunktion (304) zum Umwandeln eines Satzes von Zeitbereichseingangsabtastwerten, die jeweilige Signale (35) von den genannten mehreren (10) der  
20 lichtemittierenden Geräte (12, 14) repräsentieren, in einen entsprechenden Satz von Frequenzbereichsabtastwerten umfasst und die genannte Steuereinheit (50) Steuersignale zum Reduzieren der zum Erzeugen der genannten Frequenzbereichsabtastwerte in dem genannten Energiesparmodus erforderlichen Verarbeitung anlegt.  
25

10. System (10) nach Anspruch 9, bei dem die Zahl der Abtastwerte in dem Satz von Zeitbereichsabtastwerten (35) in dem genannten Energiesparmodus verringert ist.

11. System (1) nach Anspruch 9 oder 10, bei dem die Geschwindigkeit, mit der aufeinanderfolgende Sätze von Zeitbereichsabtastwerten (35) in entsprechende Sätze von Frequenzbereichsausgangsabtastwerten umgewandelt werden, in dem genannten Energiesparmodus verringert ist.  
30

12. System (1) nach einem der vorhergehenden Ansprüche, bei dem die genannte Steuereinheit (50) in einem Energiesparmodus ein Steuersignal zum Ausschalten des genannten wenigstens einen der genannten mehreren (10) lichtemittierenden Geräte (12, 14) für eine benutzerkonfigurierbare vorbestimmte Zeitdauer anlegt und einen medizinischen Patientenparameter überwacht, der ohne die Verwendung des genannten wenigstens einen der genannten mehreren (10) lichtemittierenden Geräte (12, 14) gemessen wird, und  
35 die genannte Steuereinheit (50) als Reaktion auf eine Bestimmung, dass der genannte überwachte Wert des medizinischen Patientenparameters außerhalb eines vorbestimmten Bereichs liegt, den genannten Energiesparmodus beendet und das genannte wenigstens eine der genannten mehreren (10) lichtemittierenden Geräte (12, 14) einschaltet.  
40

13. System (1) nach einem der vorhergehenden Ansprüche, bei dem wenigstens eines der genannten Steuersignale in einem Energiesparmodus wenigstens eines der genannten mehreren (10) lichtemittierenden Geräte (12,14) für eine vorbestimmte Zeitdauer ausschaltet und die genannte Steuereinheit (50)  
45 einen medizinischen Patientenparameter überwacht, der ohne die Verwendung des genannten wenigstens einen lichtemittierenden Geräts (12, 14) gemessen wird, und als Reaktion auf eine Bestimmung, dass der genannte überwachte Wert des medizinischen Patientenparameters außerhalb eines vorbestimmten Bereichs liegt, den genannten Energiesparmodus beendet und die genannten mehreren lichtemittierenden Geräte (12, 14) einschaltet.  
50

14. System (1) nach Anspruch 13, bei dem die genannte Steuereinheit (50) ein Steuersignal anlegt, das den Betrieb der beim Ableiten des genannten medizinischen Patientenparameters, der ohne Verwendung des genannten wenigstens einen lichtemittierenden Geräts (12, 14) gemessen wird, unbenutzten Medizingerätfunktionen abschaltet.  
55

15. System (1) nach Anspruch 13 oder 14, ferner umfassend:

einen Datenprozessor (40), der mehrere verschiedene Verarbeitungsfunktionen zum Verarbeiten von unter Verwendung von wenigstens einem der genannten mehreren (10) lichtemittierenden Geräte (12, 14) abgeleiteten Daten beim Bestimmen eines von dem genannten medizinischen Gerät gemessenen medizinischen Patientenparameterwerts einsetzt, wobei:

5 die genannte Steuereinheit (50) ein Steuersignal zum Ausschalten wenigstens einer Verarbeitungsfunktion der genannten mehreren Verarbeitungsfunktionen in einem Energiesparmodus als Reaktion auf eine Empfindlichkeitsbestimmung (308) anlegt, wobei die genannte Empfindlichkeitsbestimmung (308) zum Ausschalten einer Funktion verwendet wird, die bei der genannten Bestimmung des genannten, von dem  
10 genannten medizinischen Gerät gemessenen Werts des medizinischen Patientenparameters die geringste Wirkung hat.

16. System (1) nach einem der Ansprüche 13 bis 15, bei dem:

15 der genannte überwachte Wert des medizinischen Patientenparameters wenigstens einen der Folgenden umfasst:

20 einen mit der Herzfrequenz verbundenen Parameterwert,  
eine Änderungsquote eines für den Blutsauerstoff repräsentativen Parameters,  
Patiententemperatur,  
arterieller Blutdruck,  
einen Hämatokritwert und  
einen Herzindex.

25 17. System (1) nach einem der Ansprüche 13 bis 16, bei dem die genannte vorbestimmte Zeitdauer benutzerkonfigurierbar ist.

30 18. System (1) nach einem der Ansprüche 13 bis 17, bei dem die genannte vorbestimmte Zeitdauer von dem genannten System (1) eingestellt werden kann.

19. System (1) nach einem der Ansprüche 13 bis 18, bei dem die genannte Steuereinheit (50) ferner:

35 ein Steuersignal zum Ausschalten der Verarbeitung von Daten anlegt, die beim Ableiten eines medizinischen Patientenparameters unter Verwendung von wenigstens einem der genannten lichtemittierenden Geräte (12, 14) in dem genannten Stromsparmodus stattfindet.

40 20. System (1) nach Anspruch 19, bei dem der genannte, unter Verwendung des genannten lichtemittierenden Geräts abgeleitete medizinische Patientenparameter (a) einen für die Blutsauerstoffsättigung repräsentativen Parameter und/oder (b) eine Pulszahl umfasst.

21. System (1) nach Anspruch 1, ferner umfassend:

45 einen Datenprozessor (40), der mehrere verschiedene Verarbeitungsfunktionen zum Verarbeiten von unter Verwendung von wenigstens einem der genannten lichtemittierenden Geräte (12, 14) abgeleiteten Daten beim Bestimmen eines von dem genannten medizinischen Gerät gemessenen Werts eines medizinischen Patientenparameters einsetzt,

50 wobei die genannte Steuereinheit (50) ferner ein Steuersignal zum Ausschalten wenigstens einer Verarbeitungsfunktion der genannten mehreren Verarbeitungsfunktionen in einem Energiesparmodus als Reaktion auf eine vorbestimmte Funktionsdeaktivierungsprozedur anlegt.

55 22. System (1) nach Anspruch 21, bei dem die genannte vorbestimmte Funktionsdeaktivierungsprozedur die genannte wenigstens eine Verarbeitungsfunktion als Reaktion auf eine Empfindlichkeitsbestimmung (308) ausschaltet, wobei die genannte Empfindlichkeitsbestimmung (308) zum Ausschalten einer Funktion verwendet wird, die bei der genannten Bestimmung des genannten, von dem genannten medizinischen Gerät gemessenen Werts des medizinischen Patientenparameters die geringste Wirkung hat.

23. System (1) nach Anspruch 22, bei dem die genannte Steuereinheit (50) Steuersignale zum fortschreitenden Aus-

## EP 1 741 384 B1

schalten von Verarbeitungsfunktionen der genannten mehreren Verarbeitungsfunktionen in dem genannten Energiesparmodus als Reaktion auf Empfindlichkeitsbestimmungen (308) anlegt.

5 24. System (1) nach einem der Ansprüche 21 bis 23, bei dem  
die genannte Steuereinheit (50) Steuersignale zum aussetzenden Ausschalten der genannten mehreren (10) lichtemittierenden Geräte (12, 14) in einem Energiesparmodus als Reaktion auf eine Bestimmung anlegt, dass ein von dem genannten medizinischen Gerät unter Verwendung eines aktiven lichtemittierenden Geräts (12, 14) der genannten mehreren (10) lichtemittierenden Geräte (12, 14) gemessener Wert eines medizinischen Patientenparameters auf einem sicheren Pegel liegt.

10 25. System (1) nach einem der Ansprüche 21 bis 24, bei dem:

ein erstes Steuersignal in einem Energiesparmodus wenigstens eines der genannten lichtemittierenden Geräte (12, 14) für eine benutzerkonfigurierbare vorbestimmte Zeitdauer ausschaltet und  
15 die genannte Steuereinheit (50) einen medizinischen Patientenparameter überwacht, der ohne die Verwendung von wenigstens einem der genannten lichtemittierenden Geräte (12, 14) gemessen wird, und als Reaktion auf eine Bestimmung, dass der genannte überwachte medizinische Patientenparameterwert außerhalb eines vorbestimmten Bereichs liegt, den genannten Energiesparmodus beendet und die genannten lichtemittierenden Geräte (12, 14) einschaltet.

20 26. System (1) nach Anspruch 1, bei dem:

wenigstens eines der genannten lichtemittierenden Geräte (12, 14) bei der Überwachung eines ersten Parameters, der einen Patientenparameter in Verbindung mit Blutsauerstoff umfasst, verwendet wird und  
25 die genannte Steuereinheit (50)  
ein Steuersignal zum Einleiten des Ausschaltens des genannten wenigstens einen lichtemittierenden Geräts für eine vorbestimmte Zeitdauer in einem Energiesparmodus anlegt und  
als Reaktion auf eine Bestimmung, dass ein überwachter zweiter Parameter einen Wert außerhalb eines vorbestimmten Bereichs hat, wobei der genannte überwachte zweite Parameter, der einen medizinischen Patientenparameter umfasst, der ohne Verwendung des genannten wenigstens einen lichtemittierenden Geräts gemessen wird, das genannte lichtemittierende Gerät einschaltet.

30 27. System (1) nach Anspruch 1, bei dem:

35 die genannte Energieversorgungseinheit (60) die Verarbeitung von Daten ausschaltet, die beim Ableiten eines medizinischen Patientenparameters unter Verwendung von wenigstens einem der genannten lichtemittierenden Geräte (12, 14) stattfindet, und  
die genannte Steuereinheit (50) einen medizinischen Patientenparameter überwacht, der ohne die Verwendung des genannten wenigstens einen der genannten lichtemittierenden Geräte gemessen wird, und  
40 als Reaktion auf eine Bestimmung, dass der genannte überwachte Wert des medizinischen Patientenparameters außerhalb eines vorbestimmten Bereichs liegt, das genannte wenigstens eine der genannten lichtemittierenden Geräte einschaltet.

45 28. System (1) nach einem der Ansprüche 21 bis 27, bei dem die genannte Steuereinheit (50) ein Steuersignal anlegt, das wenigstens eine Verarbeitungsfunktion von mehreren Verarbeitungsfunktionen in dem genannten Energiesparmodus als Reaktion auf eine Empfindlichkeitsbestimmung (308) ausschaltet, wobei die genannte Empfindlichkeitsbestimmung (308) zum Ausschalten einer Funktion verwendet wird, die bei der genannten Bestimmung des genannten, von dem genannten medizinischen Gerät gemessenen Werts des medizinischen Patientenparameters die geringste Wirkung hat.

### Revendications

55 1. Système (1) destiné à ajuster la puissance employée par un dispositif médical incorporant des dispositifs électroluminescents et étant utilisé pour mesurer des paramètres médicaux d'un patient, comportant :

une pluralité (10) de dispositifs électroluminescents (12, 14) ;  
un bloc d'alimentation (60) couplé auxdits dispositifs électroluminescents (12, 14) pour alimenter lesdits dispo-

## EP 1 741 384 B1

5 sitifs électroluminescents (12, 14) en réponse à des signaux de commande respectifs pour déterminer la puissance appliquée auxdits dispositifs électroluminescents (12, 14) ; et  
une unité de commande (50) destinée à mettre en oeuvre lesdits signaux de commande et étant couplée au bloc d'alimentation (60), lesdits signaux de commande éteignant de façon discontinue au moins l'un de ladite pluralité (10) de dispositifs électroluminescents (12, 14) dans un mode d'économie d'énergie en réponse à une détermination qu'une valeur de paramètre médical de patient mesurée par ledit dispositif médical, en utilisant un dispositif électroluminescent actif (12, 14) de ladite pluralité (10) de dispositifs électroluminescents (12, 14), est à un niveau sûr ;

10 **caractérisé en ce que**, en mode d'économie d'énergie, au moins l'un de ladite pluralité de dispositifs électroluminescents est maintenu dans un état actif.

15 2. Système (1) selon la revendication 1, dans lequel ladite unité de commande (50) détermine qu'une valeur de paramètre médical de patient comportant une valeur représentative de saturation en oxygène dans le sang est audit niveau sûr quand elle est au-dessus d'un seuil prédéterminé.

20 3. Système (1) selon la revendication 1 ou la revendication 2, dans lequel ladite unité de commande (50) détermine qu'une valeur de paramètre médical de patient comportant une fréquence de pouls est audit niveau sûr quand elle est dans les limites d'une plage prédéterminée.

25 4. Système (1) selon l'une quelconque des revendications précédentes, dans lequel ledit paramètre médical de patient comporte au moins l'un quelconque parmi:

un paramètre représentatif de saturation en oxygène dans le sang ;  
un changement au niveau d'un paramètre représentatif de saturation en oxygène dans le sang ;  
un taux de changement d'un paramètre représentatif de saturation en oxygène dans le sang ;  
une fréquence de pouls ;  
un changement de la fréquence de pouls ;  
la température du patient ;  
la tension artérielle ;  
un niveau d'hématocrite ; et  
un index cardiaque.

35 5. Système (1) selon l'une quelconque des revendications précédentes, dans lequel lesdits signaux de commande éteignent de façon discontinue au moins un différent premier dispositif électroluminescent (12) et un différent deuxième dispositif électroluminescent (14) de ladite pluralité (10) de dispositifs électroluminescents et :

40 ledit dispositif médical stocke une valeur de paramètre (42) obtenue en utilisant un premier dispositif électroluminescent actif (12) avant d'éteindre ledit dispositif électroluminescent actif (12).

45 6. Système (1) selon la revendication 5, dans lequel ladite unité de commande (50) utilise ladite valeur de paramètre stockée (42) obtenue en utilisant ledit premier dispositif électroluminescent (12) avec une valeur de paramètre obtenue en utilisant un deuxième dispositif électroluminescent actif (14) pour déterminer que ladite valeur de paramètre médical de patient mesurée par ledit dispositif médical est à un niveau sûr.

50 7. Système (1) selon la revendication 5 ou la revendication 6, comportant par ailleurs :

un système de traitement de données (40) utilisant une pluralité (10) de différentes fonctions de traitement pour traiter des données dérivées en utilisant ladite pluralité (10) de dispositifs électroluminescents (12, 14) lors de la détermination de ladite valeur de paramètre médical de patient mesurée par ledit dispositif médical ;

dans lequel :

55 ladite unité de commande (50) met en oeuvre un signal de commande pour éteindre au moins une fonction de traitement de ladite pluralité de fonctions de traitement dans ledit mode d'économie d'énergie en réponse à une détermination de sensibilité (308), ladite détermination de sensibilité (308) étant utilisée pour éteindre une

fonction ayant un moindre effet dans ladite détermination de ladite valeur de paramètre médical de patient mesurée par ledit dispositif médical.

- 5 8. Système (1) selon la revendication 7, dans lequel ladite unité de commande (50) met en oeuvre des signaux de commande pour éteindre progressivement des fonctions de traitement de ladite pluralité de fonctions de traitement dans ledit mode d'économie d'énergie en réponse à des déterminations de sensibilité (308).
- 10 9. Système (1) selon la revendication 7 ou la revendication 8, dans lequel un sous-ensemble de la pluralité de fonctions de traitement (306) opère dans le domaine fréquentiel ; le système comporte par ailleurs une fonction de traitement de transformation de Fourier rapide (FFT) (304), pour transformer un ensemble d'échantillons d'entrée de domaine temporel, représentant des signaux respectifs (35) provenant de ladite pluralité (10) de dispositifs électroluminescents (12, 14), en un ensemble correspondant d'échantillons de domaine fréquentiel ; et ladite unité de commande (50) met en oeuvre des signaux de commande pour réduire le traitement nécessaire pour produire lesdits échantillons de domaine fréquentiel dans ledit mode d'économie d'énergie.
- 15 10. Système (1) selon la revendication 9, dans lequel le nombre d'échantillons dans l'ensemble d'échantillons de domaine temporel (35) est réduit dans ledit mode d'économie d'énergie.
- 20 11. Système (1) selon la revendication 9 ou la revendication 10, dans lequel le taux auquel des ensembles successifs d'échantillons de domaine temporel (35) sont transformés en ensembles correspondants d'échantillons de sortie de domaine fréquentiel est réduit dans ledit mode d'économie d'énergie.
- 25 12. Système (1) selon l'une quelconque des revendications précédentes, dans lequel ladite unité de commande (50) met en oeuvre un signal de commande pour éteindre ledit au moins un de ladite pluralité (10) de dispositifs électroluminescents (12, 14) dans un mode d'économie d'énergie pendant une durée de temps prédéterminée configurable par l'utilisateur et surveille un paramètre médical de patient qui est mesuré sans utiliser ledit au moins un de ladite pluralité (10) de dispositifs électroluminescents (12, 14) ; et en réponse à une détermination que ladite valeur de paramètre médical de patient surveillée est en dehors d'une plage prédéterminée, ladite unité de commande (50) met fin audit mode d'économie d'énergie et allume ledit au moins un de ladite pluralité (10) de dispositifs électroluminescents (12, 14).
- 30 13. Système (1) selon l'une quelconque des revendications précédentes, dans lequel au moins l'un desdits signaux de commande éteint au moins l'un de ladite pluralité (10) de dispositifs électroluminescents (12, 14) dans un mode d'économie d'énergie pendant une durée de temps prédéterminée, et ladite unité de commande (50) surveille un paramètre médical de patient qui est mesuré sans utiliser ledit au moins un dispositif électroluminescent (12, 14), et en réponse à une détermination que ladite valeur de paramètre médical de patient surveillée est en dehors d'une plage prédéterminée, met fin audit mode d'économie d'énergie et allume ladite pluralité de dispositifs électroluminescents (12, 14).
- 35 14. Système (1) selon la revendication 13, dans lequel ladite unité de commande (50) met en oeuvre un signal de commande pour éteindre le fonctionnement des fonctions du dispositif médical non utilisées pour la dérivation dudit paramètre médical de patient qui est mesuré sans utiliser ledit au moins un dispositif électroluminescent (12, 14).
- 40 15. Système (1) selon la revendication 13 ou la revendication 14, comportant par ailleurs :
- 45 un système de traitement de données (40) utilisant une pluralité de différentes fonctions de traitement pour traiter des données dérivées en utilisant au moins l'un de ladite pluralité (10) de dispositifs électroluminescents (12, 14) lors de la détermination de ladite valeur de paramètre médical de patient mesurée par ledit dispositif médical ;
- 50 dans lequel :
- 55 ladite unité de commande (50) met en oeuvre un signal de commande pour éteindre au moins une fonction de

## EP 1 741 384 B1

traitement de ladite pluralité de fonctions de traitement dans ledit mode d'économie d'énergie en réponse à une détermination de sensibilité (308), ladite détermination de sensibilité (308) étant utilisée pour éteindre une fonction ayant un moindre effet dans ladite détermination de ladite valeur de paramètre médical de patient mesurée par ledit dispositif médical.

5

- 16.** Système (1) selon l'une quelconque des revendications 13 à 15, dans lequel :

ladite valeur de paramètre médical de patient surveillée comporte au moins l'un quelconque parmi :

10

une valeur de paramètre apparentée à la fréquence cardiaque ;  
un taux de changement d'un paramètre représentatif de saturation en oxygène dans le sang ;  
la température du patient ;  
la tension artérielle ;  
un niveau d'hématocrite ; et  
un index cardiaque.

15

- 17.** Système (1) selon l'une quelconque des revendications 13 à 16, dans lequel ladite durée de temps prédéterminée est configurable par l'utilisateur.

20

- 18.** Système (1) selon l'une quelconque des revendications 13 à 17, dans lequel ladite durée de temps prédéterminée est ajustable par ledit système (1).

- 19.** Système (1) selon l'une quelconque des revendications 13 à 18, dans lequel ladite unité de commande (50)

25

met par ailleurs en oeuvre un signal de commande pour éteindre le traitement de données ayant lieu lors de la dérivation d'un paramètre médical de patient en utilisant au moins l'un desdits dispositifs électroluminescents (12, 14) dans ledit mode d'économie d'énergie.

30

- 20.** Système (1) selon la revendication 19, dans lequel ledit paramètre médical de patient dérivé en utilisant ledit dispositif électroluminescent comporte au moins l'un parmi, (a) un paramètre représentatif de saturation en oxygène dans le sang et (b) une fréquence de pouls.

- 21.** Système (1) selon la revendication 1, comportant par ailleurs :

35

un système de traitement de données (40) utilisant une pluralité de différentes fonctions de traitement pour traiter des données dérivées en utilisant au moins l'un desdits dispositifs électroluminescents (12, 14) lors de la détermination de ladite valeur de paramètre médical de patient mesurée par ledit dispositif médical ;

40

dans lequel ladite unité de commande (50) met par ailleurs en oeuvre un signal de commande pour éteindre au moins une fonction de traitement de ladite pluralité de fonctions de traitement dans ledit mode d'économie d'énergie en réponse à une procédure d'inhibition de fonction prédéterminée.

- 22.** Système (1) selon la revendication 21, dans lequel ladite procédure d'inhibition de fonction prédéterminée éteint ladite au moins une fonction de traitement en réponse à une détermination de sensibilité (308), ladite détermination de sensibilité (308) étant utilisée pour éteindre une fonction ayant un moindre effet dans ladite détermination de ladite valeur de paramètre médical de patient mesurée par ledit dispositif médical.

45

- 23.** Système (1) selon la revendication 22, dans lequel ladite unité de commande (50) met en oeuvre des signaux de commande pour éteindre progressivement des fonctions de traitement de ladite pluralité de fonctions de traitement dans ledit mode d'économie d'énergie en réponse à des déterminations de sensibilité (308).

50

- 24.** Système (1) selon l'une quelconque des revendications 21 à 23, dans lequel

55

ladite unité de commande (50) met en oeuvre des signaux de commande pour éteindre de façon discontinue ladite pluralité (10) de dispositifs électroluminescents (12, 14) dans un mode d'économie d'énergie en réponse à une détermination qu'une valeur de paramètre médical de patient mesurée par ledit dispositif médical, en utilisant un dispositif électroluminescent actif de ladite pluralité (10) de dispositifs électroluminescents (12, 14), est à un niveau

sûr.

25. Système (1) selon l'une quelconque des revendications 21 à 24, dans lequel

5 un premier signal de commande éteint au moins l'un desdits dispositifs électroluminescents (12, 14) dans un mode d'économie d'énergie pendant une durée de temps prédéterminée configurable par l'utilisateur ; et ladite unité de commande (50) surveille un paramètre médical de patient qui est mesuré sans utiliser au moins l'un desdits dispositifs électroluminescents (12, 14) et en réponse à une détermination que ledit paramètre médical de patient surveillé est en dehors d'une plage prédéterminée, met fin audit mode d'économie d'énergie et allume lesdits  
10 dispositifs électroluminescents (12, 14).

26. Système (1) selon la revendication 1, dans lequel :

15 au moins l'un desdits dispositifs électroluminescents (12, 14) est utilisé pour surveiller un premier paramètre comportant un paramètre de patient apparenté à l'oxygène dans le sang ; et ladite unité de commande (50) met en oeuvre un signal de commande pour déclencher la mise hors tension dudit au moins un dispositif électroluminescent pendant une durée de temps prédéterminée dans un mode d'économie d'énergie, et en réponse à une détermination qu'un deuxième paramètre surveillé a une valeur en dehors d'une plage  
20 prédéterminée, ledit deuxième paramètre surveillé comportant un paramètre médical de patient qui est mesuré sans utiliser ledit au moins un dispositif électroluminescent, mettant sous tension ledit dispositif électroluminescent.

27. Système (1) selon la revendication 1, dans lequel :

25 ledit bloc d'alimentation (60) arrête le traitement des données ayant lieu lors de la dérivation d'un paramètre médical de patient en utilisant au moins l'un desdits dispositifs électroluminescents (12, 14) ; et ladite unité de commande (50), surveille un paramètre médical de patient qui est mesuré sans utiliser ledit au moins un desdits dispositifs électroluminescents, et  
30 en réponse à une détermination que ladite valeur de paramètre médical de patient surveillée est en dehors d'une plage prédéterminée, allume ledit au moins un desdits dispositifs électroluminescents.

28. Système (1) selon l'une quelconque des revendications 21 à 27,

35 dans lequel ladite unité de commande (50) met en oeuvre un signal de commande destiné à éteindre au moins une fonction de traitement d'une pluralité de fonctions de traitement en réponse à une détermination de sensibilité (308), ladite détermination de sensibilité (308) étant utilisée pour éteindre une fonction ayant un moindre effet dans ladite détermination de ladite valeur de paramètre médical de patient mesurée par ledit dispositif médical.

40

45

50

55

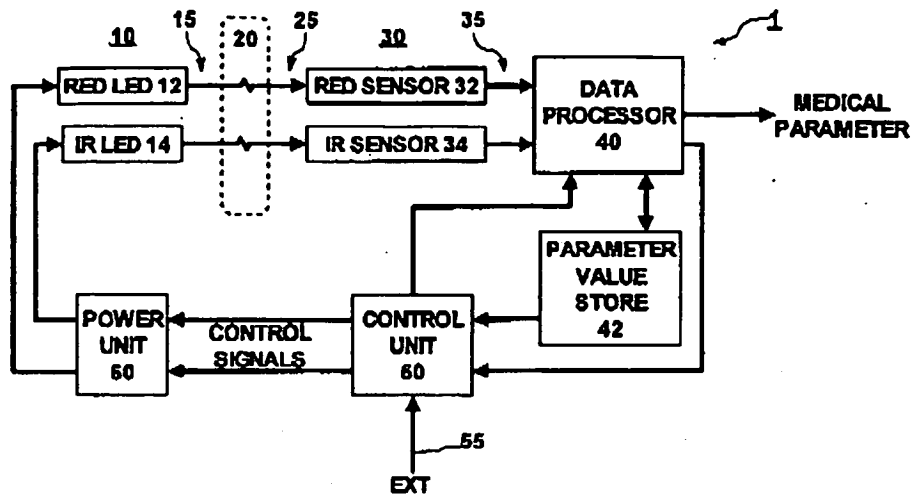

Fig. 1

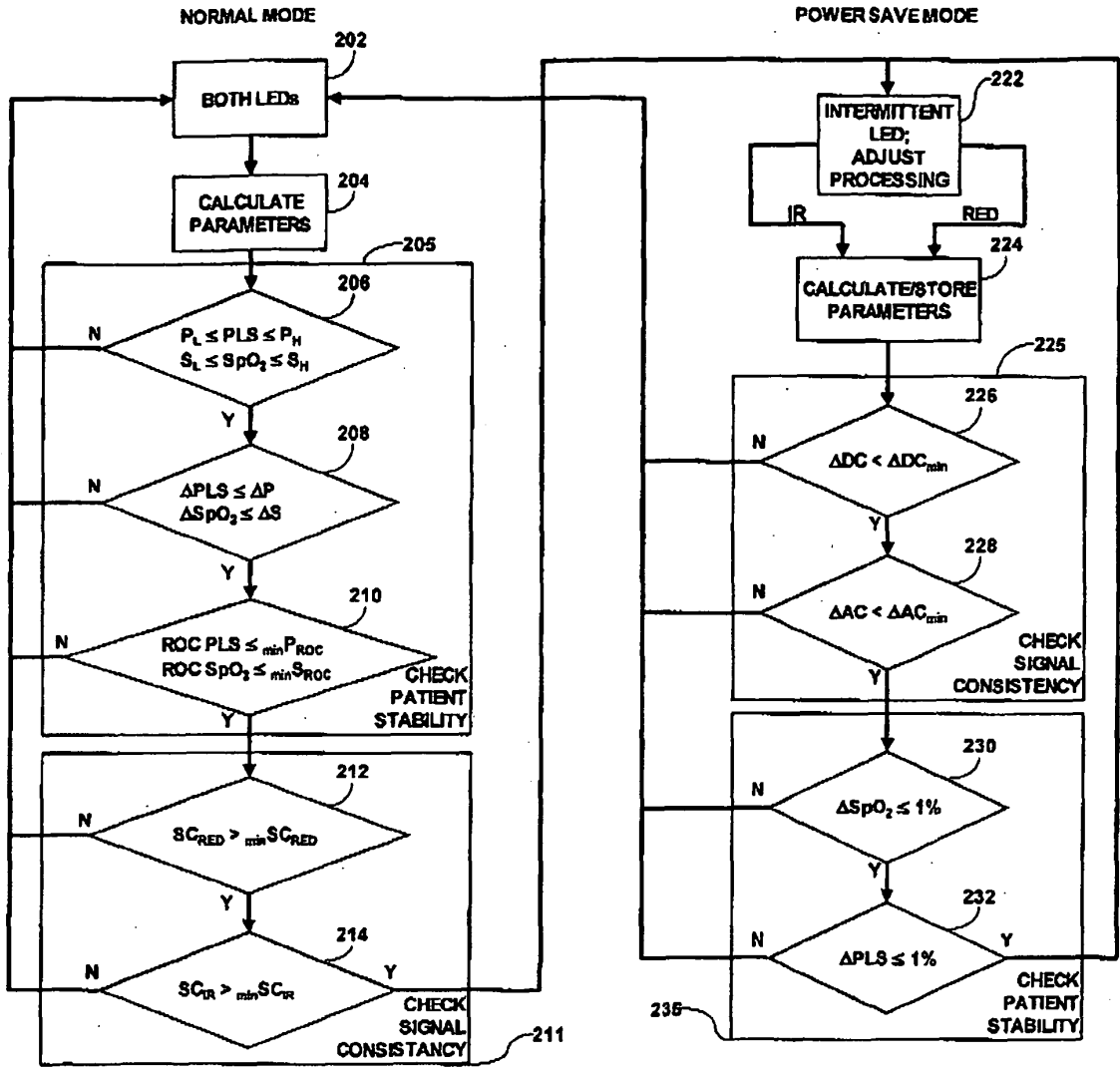

Fig. 2

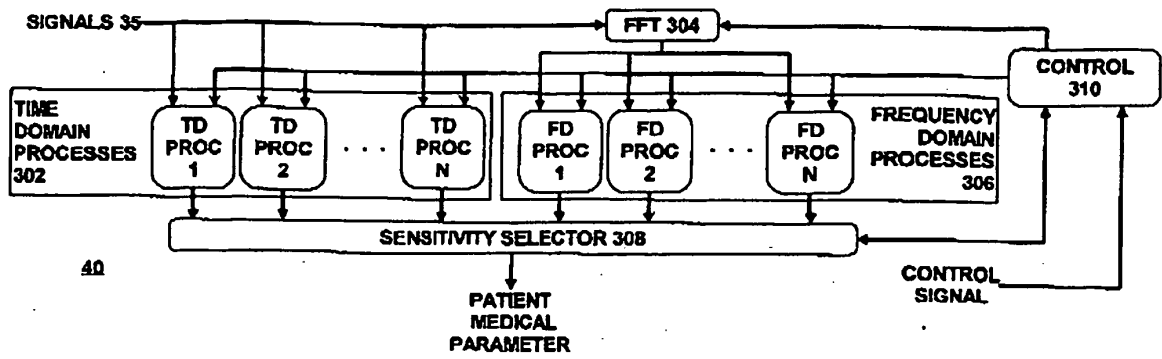

Fig. 3

**REFERENCES CITED IN THE DESCRIPTION**

*This list of references cited by the applicant is for the reader's convenience only. It does not form part of the European patent document. Even though great care has been taken in compiling the references, errors or omissions cannot be excluded and the EPO disclaims all liability in this regard.*

**Patent documents cited in the description**

- US 5924979 A [0004]

专利名称(译)	一种用于调节医疗设备所用功率的系统		
公开(公告)号	<a href="#">EP1741384B1</a>	公开(公告)日	2009-11-11
申请号	EP2006253582	申请日	2006-07-07
[标]申请(专利权)人(译)	德雷格医疗系统股份有限公司		
申请(专利权)人(译)	德尔格医疗系统公司.		
当前申请(专利权)人(译)	德尔格医疗系统公司.		
[标]发明人	HUANG JOHNNIE		
发明人	HUANG, JOHNNIE		
IPC分类号	A61B5/00		
CPC分类号	A61B5/14551 A61B5/7257 A61B2560/0209		
优先权	60/697615 2005-07-08 US		
其他公开文献	EP1741384A3 EP1741384A2		
外部链接	<a href="#">Espacenet</a>		

摘要(译)

一种用于调节由包含发光装置 ( 12,14 ) 并用于测量患者医疗参数的医疗装置所采用的电力的系统 ( 1 ) 包括多个发光装置。功率单元 ( 60 ) 耦合到发光器件并响应于确定要施加到发光器件的功率的相应控制信号而为发光器件供电。控制单元 ( 50 ) 提供控制信号并且耦合到电源单元。响应于使用多个发光的有源发光装置确定由医疗装置测量的患者医疗参数值，控制信号在省电模式下间歇地关闭多个发光装置中的至少一个发光装置。设备，处于安全水平。

$$S = \frac{1}{N} \sum_{n=1}^N (P_n - P_0) \quad (\text{Equ 1})$$