



(12) **EUROPEAN PATENT APPLICATION**

(43) Date of publication: **02.11.2006 Bulletin 2006/44**  
 (51) Int Cl.: **A61B 5/00 (2006.01)**  
 (21) Application number: **06250192.9**  
 (22) Date of filing: **13.01.2006**

(84) Designated Contracting States:  
**AT BE BG CH CY CZ DE DK EE ES FI FR GB GR HU IE IS IT LI LT LU LV MC NL PL PT RO SE SI SK TR**  
 Designated Extension States:  
**AL BA HR MK YU**  
 (30) Priority: **29.04.2005 US 117484**  
 (71) Applicant: **IDT Technology Limited**  
**Kowloon, Hong Kong SAR (CN)**

(72) Inventor: **Chan, Raymond**  
**Hunghom**  
**Kowloon**  
**Hong Kong SAR (CN)**  
 (74) Representative: **Jenkins, Richard Gavin et al**  
**Marks & Clerk**  
**43 Park Place**  
**GB-Leeds LS1 2RY (GB)**

(54) **Wireless heart rate monitoring system**

(57) A wireless heart rate monitoring system (10) comprises a detection unit (11) and a display unit (13), the two units being separate and co-operatively in communication via a wireless link. The detection unit (11) has a casing (12), straps for attaching the casing (12) on a user, a heart rate detector (14) for detecting ECG pulses of the user, a microprocessor (17) for computing a heart

rate based on the detected ECG pulses, and a transmitter (18) for transmitting a wireless signal indicative of the computed heart rate to the display unit (13). The display unit (13) has a casing, a receiver (21) for receiving the wireless signal from the detection unit (11), and a display (23) for displaying the heart rate received by the receiver (21).

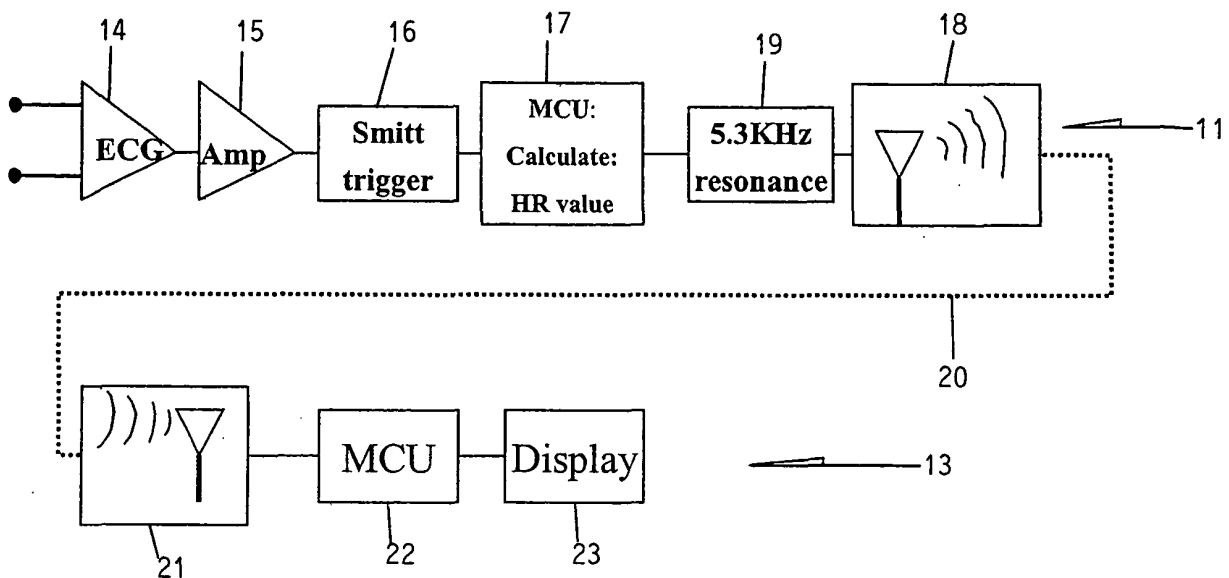

FIG. 2

**Description**

**[0001]** The present invention relates to a heart rate monitoring system.

BACKGROUND OF THE INVENTION

**[0002]** More particularly, although not exclusively, the invention is concerned with a wireless-transmission heart rate monitor comprising a body-mounted heart beat detector and a remote receiver/display unit which might also be worn on the body, for example like a watch about the wearer's wrist.

**[0003]** Conventional heart rate monitors include a body-mounted detector such as a chest belt which transmits a signal to the remote display unit upon detection of each heart beat. The remote display unit receives such signals and then calculates an ECG (electrocardiogram) pulse count for display purposes. Such apparatus are generally reliable in environments free of interference that may be caused by radiation from nearby transmitting devices such as mobile phones or power lines. This problem has been addressed to in US Patent Nos. 5,611,346 and 5,632,279.

**[0004]** In the former document, two identification pulses are generated by each body-mounted transmitter whereby the timing of all between the identification pulses corresponds to a specific time interval determined to reach transmitter-receiver pair, on the basis of which specific interval the receiver identifies the measuring pulses intended for it. In the latter document, heart beat signals (bursts) are amplitude-modulated with a frequency or a frequency sequence characteristic of the transmitter/receiver unit, on the basis of which the receiver recognises the bursts only intended for it.

**[0005]** In the known prior art, heart rate monitors including those disclosed in the above referenced US patents, the actual heart rate data (typically in beats per minute) to be displayed is not computed within the body-mounted detector unit, but rather at a remote display location for example by a wrist-watch-type main unit worn on the wrist. Moreover, the wireless signals transmitted by the transmitter to the receiver are in the form of ECG bursts to be computed at the receiving end of the wireless transmission so to speak. Accordingly, complex and often unreliable methods must be employed in an attempt to distinguish one transmission from another where multiple users - say in a hospital or sporting environment - are wearing body-mounted transmitters in local proximity to one another.

OBJECTS OF THE INVENTION

**[0006]** It is an object of the present invention to overcome or substantially ameliorate the above disadvantages and/or more generally to provide an improved wireless heart rate monitor.

SUMMARY OF THE INVENTION

**[0007]** According to the invention, there is provided a wireless heart rate monitoring system comprising a detection unit and a display unit, the two units being separate and co-operatively in communication via a wireless link. The detection unit comprises a casing, attaching means at the casing for attaching the casing on a user, a heart rate detector at the casing for detecting ECG pulses of said user, a microprocessor in the casing for computing a heart rate based on the ECG pulses detected by the heart rate detector, and a transmitter at the casing for transmitting a wireless signal indicative of the heart rate computed by the microprocessor to the display unit.

The display unit comprises a casing, a receiver at the casing for receiving said wireless signal from the detection unit, and a display at the casing for displaying the heart rate received by the receiver.

**[0008]** Preferably, the attaching means comprises a strap or straps for attaching around the chest of said user.

**[0009]** Preferably, the display unit is of a wrist-mounted type.

**[0010]** It is preferred that the transmitter comprises a radio frequency transmitter and the receiver comprises a radio frequency receiver.

**[0011]** It is preferred that the transmitter is controlled by the microprocessor to transmit said wireless signal at substantially fixed intervals.

**[0012]** In a preferred embodiment, the detection unit includes timing means for controlling its transmitter to transmit said wireless signal at a different time from that of another detection unit nearby.

**[0013]** More preferably, the transmitter is controlled by the microprocessor to transmit said wireless signal at substantially fixed intervals, and the timing means comprises a series of time slots divided from said fixed interval, one of which time slots is allocated for the transmitter to transmit said wireless signal.

**[0014]** Further more preferably, the detection unit includes an operator, successive depression of which shifts the time of transmission of said wireless signal from one time slot to the next until a vacant time slot is reached.

**[0015]** In a preferred embodiment, said wireless signal comprises a coded data packet that includes data representing the heart rate computed by the microprocessor.

**[0016]** More preferably, the coded data packet further includes a code identifying the detection unit.

BRIEF DESCRIPTION OF DRAWINGS

**[0017]** The invention will now be more particularly described, by way of example only, with reference to the accompanying drawings, in which:

Figure 1 is a front view of an embodiment of a wireless heart rate monitoring system in accordance with the invention, comprising a chest-belt detection unit and a wrist-mounted display unit;

Figure 2 is a schematic functional block diagram of the transmitting and receiving units of Figure 1;

Figures 3A to 3C are schematic waveform diagrams showing comparison of transmission protocol between the present invention and the prior art; and

Figures 4A to 4C are schematic waveform diagrams showing signals transmitted by the detection unit to the display unit.

#### DETAILED DESCRIPTION OF PREFERRED EMBODIMENT

**[0018]** Referring initially to Figures 1 and 2 of the drawings, there is shown a wireless heart rate monitoring system 10 embodying the invention, which comprises two separate units i.e. a detection unit 11 and a display unit 13 that are in communication with each other via a wireless link 20 for operation.

**[0019]** The detection unit 11 is in the form of a chest belt, including a strap or straps for attaching around the chest of a user for detection of his/her heartbeat. The display unit 13 resembles a wrist-watch which has an LCD display panel 23 on its casing for displaying a measured heart rate.

**[0020]** The detection unit 11 has a casing 12 and a heart rate detector 14 supported thereby on the rear side for bearing against the user's chest to detect his/her heartbeat. Housed in the casing 12 and connected in series from the detector 14, there are an amplifier 15, a Smitt trigger 16, an MCU (microprocessor control unit) 17, a 5.3kHz modulator 19 and an RF (radio frequency) transmitter 18.

**[0021]** The detected heartbeat, an ECG signal, will be amplified by the amplifier 15 and then converted by the Smitt trigger 16 into pulses for subsequent processing by the MCU 17. Compared with general triggers, the Smitt trigger 16 offers the advantage of better control over false trigger signals as may be caused by noises.

**[0022]** The MCU 17 is programmed, inter alia, to calculate a heart rate (beats per minute) based on the heartbeat pulses input by the Smitt trigger 16 and then to transform the calculated heart rate into a coded data packet. Besides the calculated heart rate, the MCU 17 includes in the coded data packet a user ID code that actually identifies the detection unit 11, a travelling speed of and/or distance covered by the user also determined by the MCU 17 as auxiliary functions, and error correction bits.

**[0023]** The coded data packet is fed to the transmitter 18, via the modulator 19 for modulation thereby before being transmitted by the transmitter 18 as a wireless RF signal at 5.3kHz resonance under the control of the microprocessor 17, for reception by the display unit 13.

**[0024]** The display unit 13 includes an RF receiver 21 for receiving the RF signal, i.e. coded data packet, from the detection unit 11, and its own MCU 22 for control

including demodulating and processing the coded data packet to extract the encoded data therefrom, i.e. the calculated heart rate and travelling speed/distance if included, for display on the LCD panel 23.

**[0025]** Figure 3A shows a typical heart rate sequence 30, in that each pulse of the waveform represents a heart beat. A typical RF protocol 31 for a conventional wireless heart rate monitor is shown in Figure 3B, according to which a burst of pulses is transmitted each time a heartbeat is detected. The heart rate is then calculated at the remote display unit, and displayed. As the bursts of pulses are fairly basic in structure, their transmission is vulnerable to interference by other RF sources, and this sometimes leads to incorrect heart rate readings.

**[0026]** With the use of the subject monitoring system 10, heart rate computation is done right at the detection unit 11, and the calculated heart rate is then transmitted by the detection unit 11 as a coded packet of data (i.e. the improved RF protocol of Figure 3C) including a user ID, whereby data integrity is ensured.

**[0027]** Figure 4A depicts the pulse patterns of "0" and "1", which are distinguished by their length. Figure 4B shows the data format for heart rate information signals generated by the MCU 17 of the detection unit 11 for transmission, which include a 2-bit user ID for user identification (up to four users). Immediately after the 2-bit user ID, there is a 8-bit heart rate reading, which is then followed by a 2-bit ODD parity bit.

**[0028]** Figure 4C shows the data format of generally the same signals for transmission but extended to carry the heart rate information as well as the speed information. The data string begins with a start bit, followed by the same 2-bit user ID, 8-bit heart rate reading and 2-bit ODD parity bit, and then a 4-bit speed/distance information, a 1-bit ODD parity bit and a stop bit.

**[0029]** The coded data packet contains a calculated heart rate value accompanied by a user ID code, and includes error correction bits. Upon receiving a corrupted packet, the wrist-watch receiver 13 will decode the error correction bits and provide a warning of external interference by flashing an icon, for example, on the display 23. The display 23 may hold the current screen until a correct signal is received again, or if interference persists the receiver 13 may invite the user to change location by, for example, dropping the reading to zero.

**[0030]** Heartbeat signals are gathered and computed by the MCU 17 embedded in the chest belt unit 11 attached to the user, and the computed heart rate in beats per minute is then transmitted to the wrist-mounted unit 13 for display. As the ECG pulse gathering and computation both take place right at the chest belt unit 11 that is in close contact with the user's body (heart), interference is minimised. The computed heart rate from the chest belt unit 11 is transmitted as coded data packets in fixed intervals say every two seconds, with information containing the user ID, heart rate in beats per minute, checksum and error guarding bits to ensure that data is transmitted, received and displayed accurately.

**[0031]** The subject wireless heart rate monitoring system 10 supports multiple user operation to avoid signal interference between users in the same vicinity each using a pair of the detection and display units 11 and 13. This is done by time multiplexing the heart rate transmissions from the individual users in different time slots or channels of a series.

**[0032]** The time slots are preferably equal time periods divided from the aforesaid fixed interval (of say two seconds) between successive data packet transmissions, so that different detection units 11 may transmit data at different times, without crashing of data. To cater for four users, each time slot may be half a second long for a detection unit transmission interval of two seconds.

**[0033]** In each detection unit 11, there is a timing circuit or counter, which is preferably embedded in or implemented by the microprocessor 17, for determining one of the time slots for transmission. This timing circuit is associated with a button (or key or any other form of operator) provided on the front of the detection unit 11 for manual operation to change the transmission time slot.

**[0034]** In practice, upon the wrist-watch receiver 13 receiving a corrupted data packet (by reason of interference) as indicated by the flashing icon, the user should press the said button on the detection unit 11 successively to trigger the timing circuit to switch or shift the time of data transmission to the next time slot until an open or vacant time slot is reached (i.e. the interference problem ceases).

**[0035]** As the heart rate is calculated inside the chest belt unit 11, the remote display unit 13 can be a very simple device for merely receiving and displaying data. With the use of a coherent design on the data packet transmission protocol, the display unit 13 may receive and display data from any other categories of data-transmitting devices such as body fat scales, blood pressure meters and pedometers, etc., whereby a generic health care monitoring system is made possible.

**[0036]** It should be appreciated that modifications of and/or alterations to the described embodiment obvious to persons skilled in the art are not to be considered as beyond the scope of the present invention. For example, a bi-directional wireless communication link may be used between the detection and display units. Furthermore, the display unit may be designed to recognise and receive signals from different heartbeat detection units by other manufacturers found on the market, by including the necessary circuitry for data decoding or conversion, etc.

## Claims

1. A wireless heart rate monitoring system comprising:

a detection unit and a display unit, the two units being separate and co-operatively in communi-

cation via a wireless link;  
the detection unit comprising:

a casing;  
attaching means at the casing for attaching the casing on a user;  
a heart rate detector at the casing for detecting ECG pulses of said user;  
a microprocessor in the casing for computing a heart rate based on the ECG pulses detected by the heart rate detector; and  
a transmitter at the casing for transmitting a wireless signal indicative of the heart rate computed by the microprocessor to the display unit;

the display unit comprising:

a casing;  
a receiver at the casing for receiving said wireless signal from the detection unit; and  
a display at the casing for displaying the heart rate received by the receiver.

2. The monitoring system as claimed in claim 1, **characterized in that** the attaching means comprises a strap or straps for attaching around the chest of said user.
3. The monitoring system as claimed in claim 1, **characterized in that** the display unit is of a wrist-mounted type.
4. The monitoring system as claimed in claim 1, **characterized in that** the transmitter comprises a radio frequency transmitter and the receiver comprises a radio frequency receiver.
5. The monitoring system as claimed in claim 1, **characterized in that** the transmitter is controlled by the microprocessor to transmit said wireless signal at substantially fixed intervals.
6. The monitoring system as claimed in any one of claims. 1 to 5, **characterized in that** the detection unit includes timing means for controlling its transmitter to transmit said wireless signal at a different time from that of another detection unit nearby.
7. The monitoring system as claimed in claim 6, **characterized in that** the transmitter is controlled by the microprocessor to transmit said wireless signal at substantially fixed intervals, and the timing means comprises a series of time slots divided from said fixed interval, one of which time slots is allocated for the transmitter to transmit said wireless signal.
8. The monitoring system as claimed in claim 7, **char-**

**acterized in that** the detection unit includes an operator, successive depression of which shifts the time of transmission of said wireless signal from one time slot to the next until a vacant time slot is reached.

5

9. The monitoring system as claimed in any one of claims 1 to 5, **characterized in that** said wireless signal comprises a coded data packet that includes data representing the heart rate computed by the microprocessor.

10

10. The monitoring system as claimed in claim 9, **characterized in that** the coded data packet further includes a code identifying the detection unit.

15

20

25

30

35

40

45

50

55

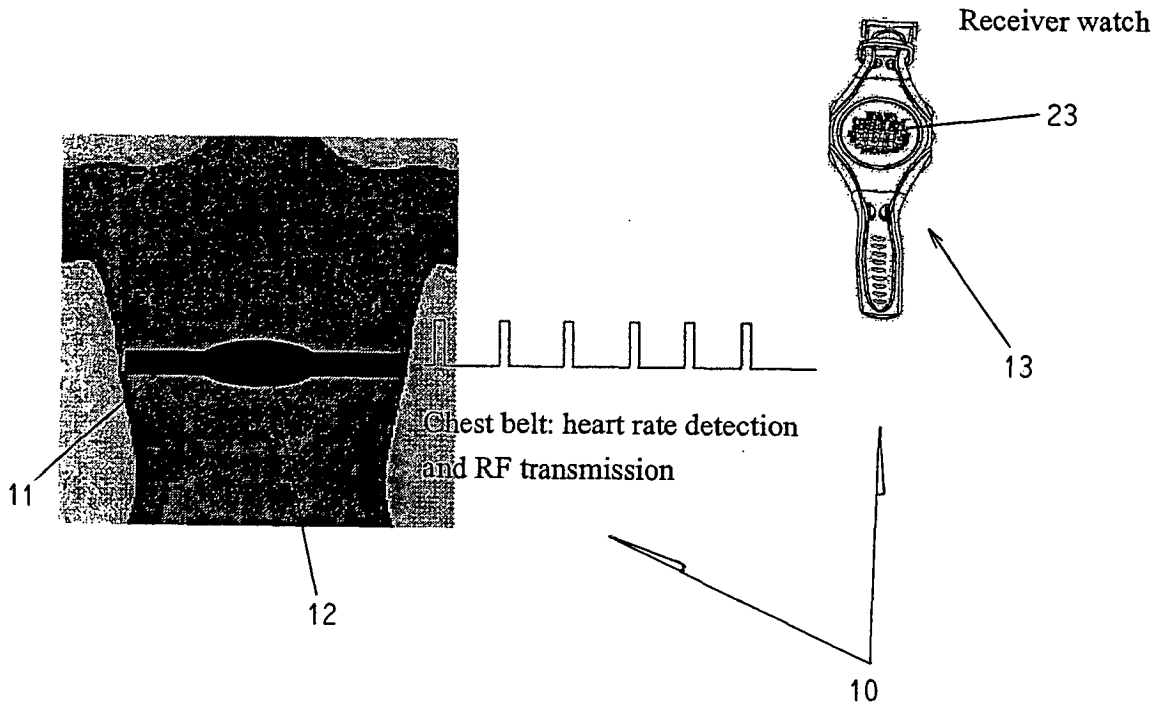

FIG. 1

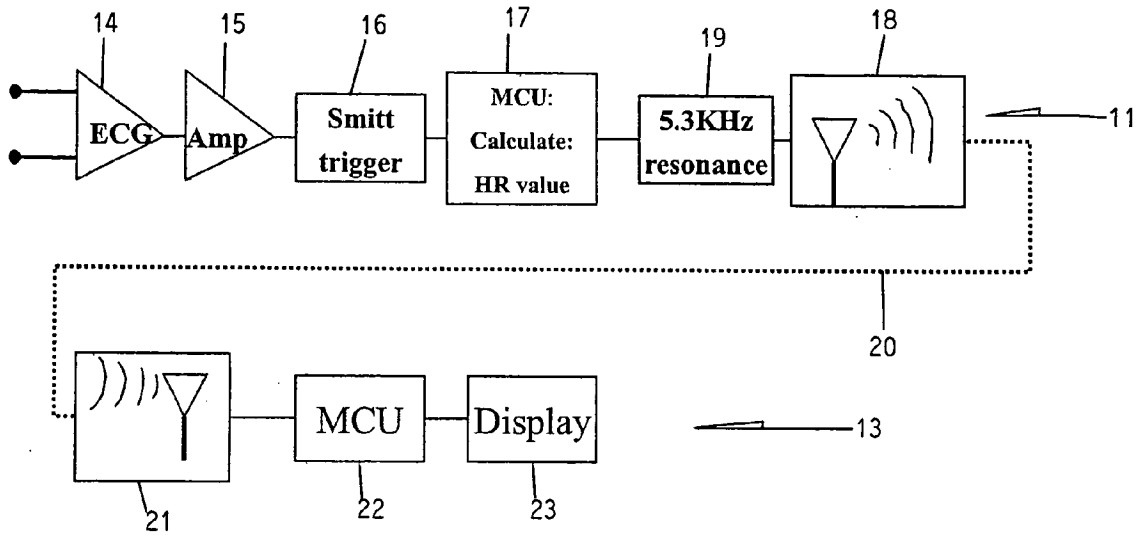

FIG. 2

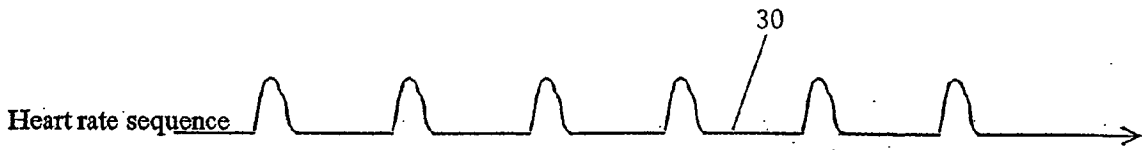

FIG. 3A

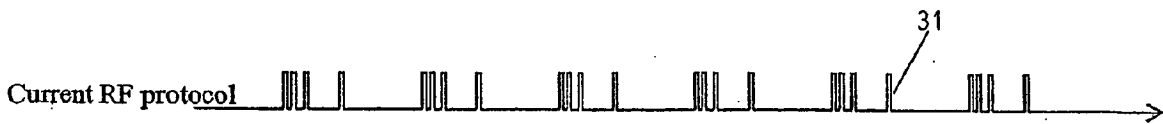

FIG. 3B

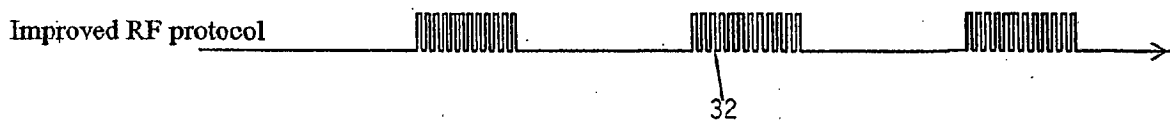

FIG. 3C

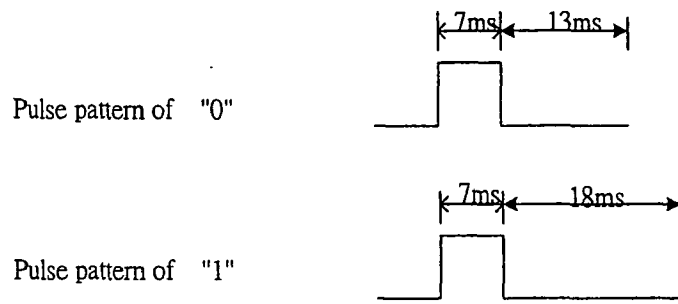

FIG. 4A

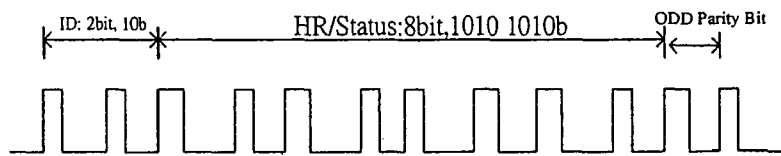

FIG. 4B

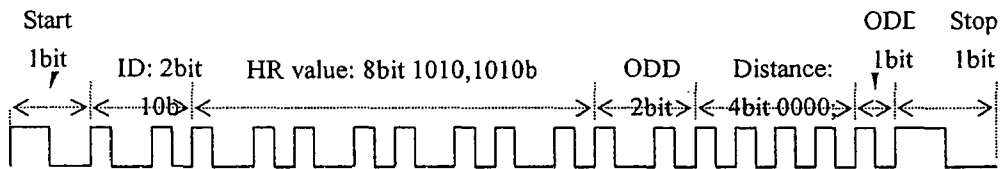

FIG. 4C



DOCUMENTS CONSIDERED TO BE RELEVANT			
Category	Citation of document with indication, where appropriate, of relevant passages	Relevant to claim	CLASSIFICATION OF THE APPLICATION (IPC)
X	US 2003/073911 A1 (YOSHIMURA MANABU ET AL) 17 April 2003 (2003-04-17)	1-4,9,10	A61B5/00 A61B5/00
Y	* paragraphs [0008], [0019] - [0021]; figures 1,3,4 *	5-8	
Y	----- US 2003/040305 A1 (NG RICHARD ET AL) 27 February 2003 (2003-02-27) * paragraphs [0010], [0016], [0037], [0038] *	5-8	
X	----- EP 0 836 165 A (POLAR ELECTRO OY) 15 April 1998 (1998-04-15) * column 6, lines 11-31 *	1,9,10	
			TECHNICAL FIELDS SEARCHED (IPC)
			A61B
The present search report has been drawn up for all claims			
Place of search Munich		Date of completion of the search 20 March 2006	Examiner Schoeffmann, H
CATEGORY OF CITED DOCUMENTS		T : theory or principle underlying the invention E : earlier patent document, but published on, or after the filing date D : document cited in the application L : document cited for other reasons ..... & : member of the same patent family, corresponding document	
X : particularly relevant if taken alone Y : particularly relevant if combined with another document of the same category A : technological background O : non-written disclosure P : intermediate document			

5 EPC FORM 1503 03/82 (P04001)

ANNEX TO THE EUROPEAN SEARCH REPORT  
ON EUROPEAN PATENT APPLICATION NO.

EP 06 25 0192

This annex lists the patent family members relating to the patent documents cited in the above-mentioned European search report. The members are as contained in the European Patent Office EDP file on  
The European Patent Office is in no way liable for these particulars which are merely given for the purpose of information.

20-03-2006

Patent document cited in search report		Publication date	Patent family member(s)	Publication date
US 2003073911	A1	17-04-2003	NONE	
-----				
US 2003040305	A1	27-02-2003	AU 5708001 A	30-10-2001
			CA 2403068 A1	25-10-2001
			EP 1274345 A1	15-01-2003
			JP 2004500217 T	08-01-2004
			MX PA02010272 A	25-04-2003
			WO 0178594 A1	25-10-2001
			US 6496705 B1	17-12-2002
-----				
EP 0836165	A	15-04-1998	DE 69709285 D1	31-01-2002
			DE 69709285 T2	22-08-2002
			FI 100924 B1	13-03-1998
			US 6229454 B1	08-05-2001
-----				

**REFERENCES CITED IN THE DESCRIPTION**

*This list of references cited by the applicant is for the reader's convenience only. It does not form part of the European patent document. Even though great care has been taken in compiling the references, errors or omissions cannot be excluded and the EPO disclaims all liability in this regard.*

**Patent documents cited in the description**

- US 5611346 A [0003]
- US 5632279 A [0003]

专利名称(译)	无线心率监测系统		
公开(公告)号	<a href="#">EP1716805A1</a>	公开(公告)日	2006-11-02
申请号	EP2006250192	申请日	2006-01-13
[标]申请(专利权)人(译)	万威科研有限公司		
申请(专利权)人(译)	IDT科技有限公司		
当前申请(专利权)人(译)	IDT科技有限公司		
[标]发明人	CHAN RAYMOND		
发明人	CHAN, RAYMOND		
IPC分类号	A61B5/00		
CPC分类号	A61B5/6831 A61B5/0006 A61B5/0245		
优先权	11/117484 2005-04-29 US		
其他公开文献	EP1716805B1		
外部链接	<a href="#">Espacenet</a>		

摘要(译)

无线心率监测系统 (10) 包括检测单元 (11) 和显示单元 (13)，这两个单元通过无线链路分开并协作地进行通信。检测单元 (11) 具有壳体 (12)，用于将壳体 (12) 附接到用户的带子，用于检测用户的 ECG 脉搏的心率检测器 (14)，用于计算心率的微处理器 (17) 基于检测到的 ECG 脉冲，以及发射器 (18)，用于将指示计算出的心率的无线信号发送到显示单元 (13)。显示单元 (13) 具有壳体，用于接收来自检测单元 (11) 的无线信号的接收器 (21)，以及用于显示由接收器 (21) 接收的心率的显示器 (23)。

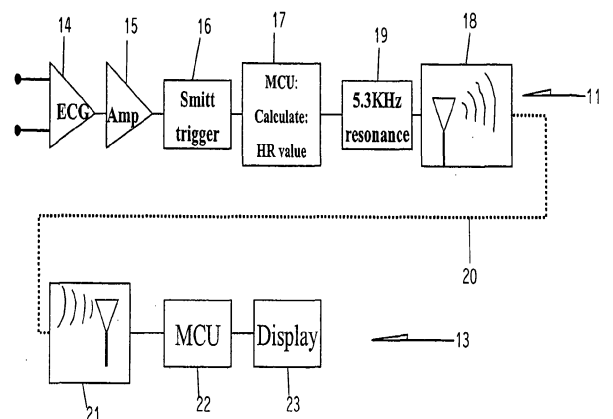

FIG. 2