



2 OLED ,

3 가 OLED ,

4 OLED

5 4 (5-5) , 4

6a 6f ,

6a ,

6b ,

6c 가 가

6d ,

6e ,

6f ,

7a 7e , 6a 6d

7a ,

7b (13pB-1) ,

7c ,

7d ,

7e ,

8 (HTL) , 4 (8-8) , 4 -

9 3 - ,

10 , 가 - 가

11 , 가 OLED 가

13p : 32 :

107 : 108 :

200 : 230 :  
 240 : 757 :  
 757f : 762 :

(organic light-emitting device; OLED)  
 (solid pellets) (physical vapor deposition)

OLED  
 EL(electroluminescent; EL) 1 2

10<sup>-3</sup> OLED (ITO) 1 2  
 가 ( ) 가 ( ) (columns)( )

(TFTs) 1 (OLED) 2  
 5,550,066

4,356,429 , 4,539,507 , 4,720,432 , 4,769,292

OLED (organic dopant) (organic hole-transporting materials), 가  
 (relatively complex molecular substrates) 가  
 (decomposition) 가 (powders), (flakes) (granules)  
 가 , 가  
 (i) , 가 (triboelectric charging)

(ii) , 0.05 0.2 g/cm<sup>3</sup> 1g/cm<sup>3</sup> ( ) .

(iii) , (evacuated) 가 , 10<sup>-6</sup> . 가 가 가 가 . - -

(iv) , / 가 , 가 가 , OLED 가 가 가 ,

OLED .

OLED

가 - 가

OLED

(a) 가 ,

(b) - 가 ,

(c) 가 - 가 ,

(d) 가 ,

(e) 가 가 , 가

(f) .

OLED

(a) ,

(b) ,

(c) (evacuate) ,

(d) 가 (a vapor of the organic material)

(handling

), (transfer) (shipping)

OLED OLED

가 (tailored)

persion) (homogeneous dis  
cess) (consolidation pro

OLED (emission layer; EML) EL (electron-hole recombina  
tion) (organic)'

(14) (12) (15) (14) 가 (pure) ,  
(tris)(8- (quino

linolato)-N1, O8) (Alq) (14) EL (11) OLED(10)  
(dopants) (12) (15) OLED(10)  
OLED (11) (transparent) , (variant)  
EL (80) (12) (11) EL

가 가 가 ( , ) ,  
EL

2 OLED(20) (EML)(25) - (24) - (26)  
(27) (25) (optional) - (22) (23) (22)



6b , (524) (13a) ( (13b)) (526)

(520) (521) , (522) (523) (524) (525)

)

6c , 가 (514) (512) ,  
 (524) (522) 가 . 가 (500) ,  
 (524) (522) (524) (522)가 (500) 가  
 (526) (13a) (13p) (500) 가  
 2,000 15,000psi , 4,000 10,000psi  
 OLED  
 가

6d , 가 (514) (520) (520)  
 (524, 522) 가 가 가 가 . 가  
 (520)가 가 , (540) 가 20 ° C 80 ° C  
 (524)

6e , (520) (500) (522) (520)  
 , (13p) (520) (521)

6f , (550) (520) (13p) (13p) (13p)  
 (560) (13p) 가 가 (520) 가 가  
 (500) 가 (13p) 가 가 50 ° C 300  
 ° C (520) (13p) (520) (520) , Tg  
 80 ° C 20 ° C

' , - (13a) ,  
 - (13p) - (13)  
 - OLED ,  
 2001 6 6 'Organic Light-Emitting Device Having a Color-Neutral Dopant in a Hole-Transport Layer and/or in an Electron-Transport Layer' 09/  
 875,646 ,

769,292 5,294,870 , 4,

2000 5 19 'Predoped Materials for Making an Organic Light-Emitting Device'  
 09/574,949 ,  
 가 ( ) (522), (520) (524) , 가 가  
 ( , 13a) ( , 13p) (520)가 300 ° C 가 가  
 가 (13p)  
 (523 525) , (522) (523) (524) (  
 525) (523 525) 가 가 ,

(co-planar major surfaces),  
 가 .

7a 7e (520) (524) (522) 6a 6  
 d (500)

7a (13pA-1 13pA-2) (13pA)

7b (13pB-1) (13pB-2) (13pB)

7c (13pC-1 13pC-2) (13pC)

7d (13pD-1 13pD-2) (13pE)

7e (13pE-1) (13pE-2) (13pE)

7a ) (13pA)(  
 ) (13pE)( 7e  
 (curvature)  
 (13pE-2)

8 , HTL, ETL EML (130) 4 (8-8)  
 가 (130H) (130C) (31)( 1 )  
 (131) (134) (132) (134)  
 5a (13pA) - (13p) (134) (245 2476)  
 (240) (244 246) 가 (135) 가  
 가  
 (13v) , ETL EML  
 OLED(30)

(31) - (crystal mass-sensor)(200)  
 (13f) - (HTL)

nitor)(220) (216) (200) (210) (deposition rate mo  
 (13f) (200) (220)  
 (220) (222) (224)  
 (232) (230) (226)  
 (234) (236) (240)

(13v) (13f)  
 (245 247) (134) 가 (220) (222) (240)  
 (135) (33)  
 (34) (35)( 3 )  
 (200) (134) 가  
 ( )  
 가 (134)가 8

9/843,489 , 2001 4 26 0

(200)가 8

OLED  
2001 4 20 09/839,886 가

OLED 2001 4 20  
09/839,885

9 (700) 가  
(CL) (710) (742) (740)  
(732 734) (710)가

3p) 가 (732 734) (710) (712) 3 (1)  
(758) (710) (712) (714) (714) (H)  
(710) (712) (L) (714) (D) (I) H (712)

700) (760) (740) (dovetail-shaped tongue)(760T)  
(threaded bore)(762) (762) ( ) ( )

2001 4 26 09/843,489

10 -3 ( , 2 HTL (130) (130C))  
(757F) 가 (13p) (757) (712) (757a 757b) (710) (714)  
(712) (CL) (732, 734)

(710) (13p) 7e (13pE) (757)  
가 가 ( 8 9) OLED  
가

6a 6f, 7a 7e, 8 9  
(13p)

4 OLED (100) (140) (34)(EML) (35)(ETL) 3

10 가 OLED - 가  
(800) (810) 가 OLED 가  
( )

(812) OLED ( ) . OLED  
 50 99 .

(820) , - 가 . - 가

(822) , - 가 ( ) 1.0-50

(830) , 가 OLED - 가

(840) , ( ) , 가 가 ,  
 Tg 50 ° C 300 ° C 가 가 .

(850) , 가가 ,  
 50 ° C 20 ° C (860) .

OLED

11 가 OLED (Alq NPB) 가 ,  
 - 가 - 가

가 OLED (900) (902) , 가 OLED .

ED (904) , 가 . OL  
 , 가

(906) ,

(900) (905) , (920) (915) - 가  
 , - 가

(912) , 1 ( 2 ) .  
 50 99 .

(922) , - 가 ( 2 ) 1 50

(930) , 1 - 가  
 2 1 - 가

(940) , 2 ( 2 ) , 2 가  
 가 2 ( 20 ° C 300 ° C ) 가 2 .

(950) , 가가 ,  
 80 ° C 20 ° C (960) .

(OLED)

1:  
 Alq (ball mill) AIN 5 10% OLED  
 3,000psi 15,000psi 가 60 ° C 300 ° C  
 ED 90% 가 OL  
 5,000 10,000psi 50 ° C 120 ° C 3,000psi 12,000psi Alq

2:

NPB AIN 5 10%  
 2000psi 15,000psi 가 60 가 200 ° C  
 3,000 8,000psi 50 ° C 120 ° C 2,000psi 10,000psi OLED  
 NPB

Alq NPB 5 25%  
 Alq Alq NPB 2,000psi Al Cu 5 25%  
 200 ° C OLED 90% 가 60  
 OLED Cu Al

1 가  
 2

, OLED 가 ,  
 , OLED 가 ,  
 , OLED 가

(57)

1.

- (a) 가 (sublimable organic material) ,
- (b) erial) , - 가 (a thermally conductive and non-sublimable ceramic mat
- (c) 가 - 가 ,
- (d) , 가
- (e) 가 (consolidate) 가 , 가
- (f)

**2.**

- OLED 1 ,
- (a) ,
  - (b) ,
  - (c) (evacuating) ,
  - (d) 가 (a vapor of t
- he organic material)

**3.**

- 1 ,
- (a) - , -

**4.**

- 3 ,
- (a) - (organic hole-transporting host material)  
(organic emission host material)

**5.**

- 1 ,
- ,
- .

6.

5 ,  
(c) 50 99  
50 - 가

1

7.

2 ,  
(a)

1  
(종래기술)

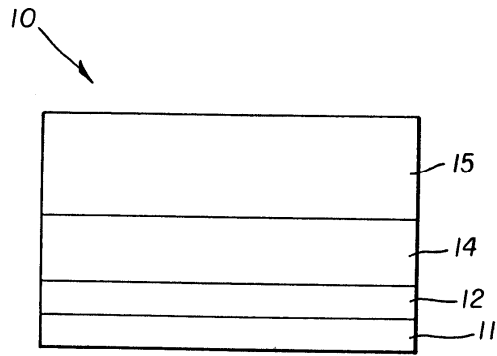

2  
(종래기술)

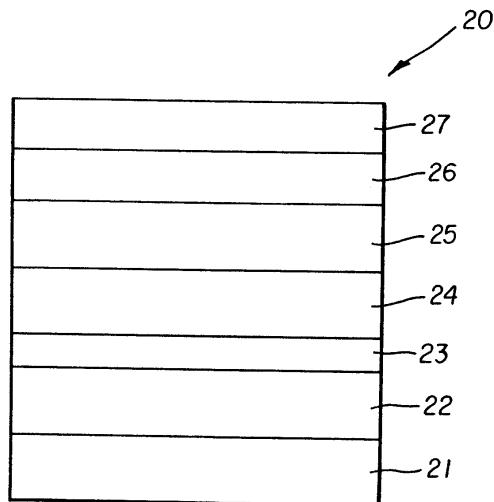

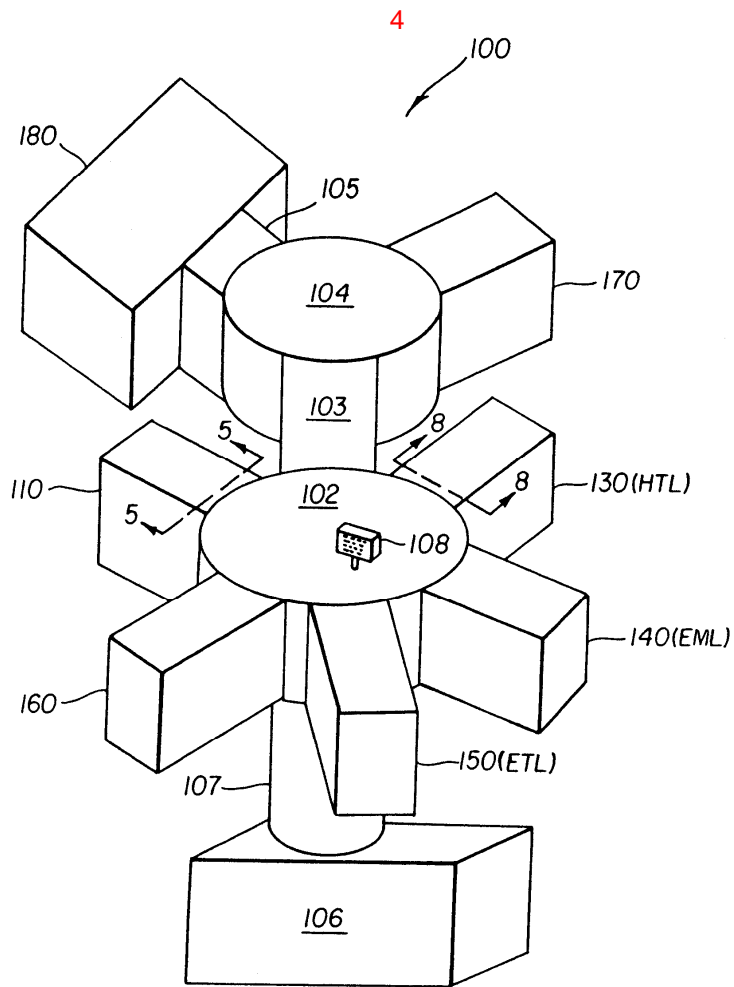
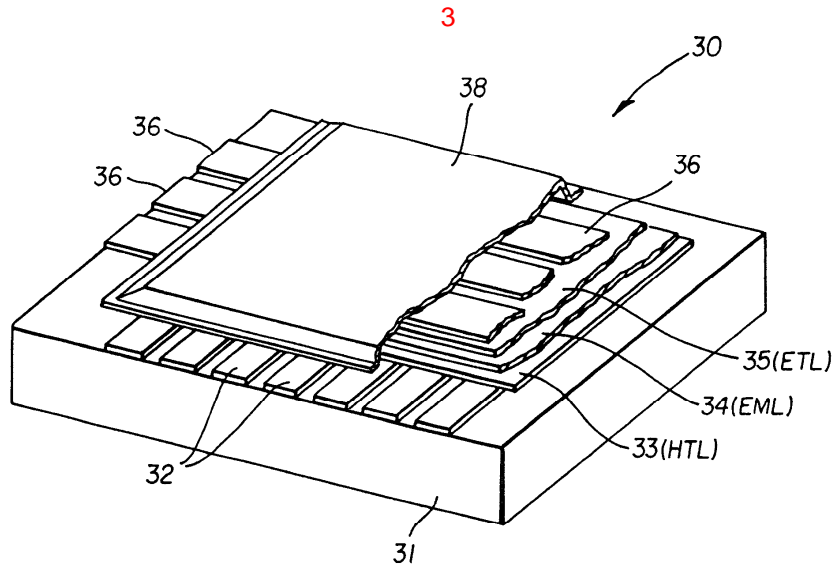

5

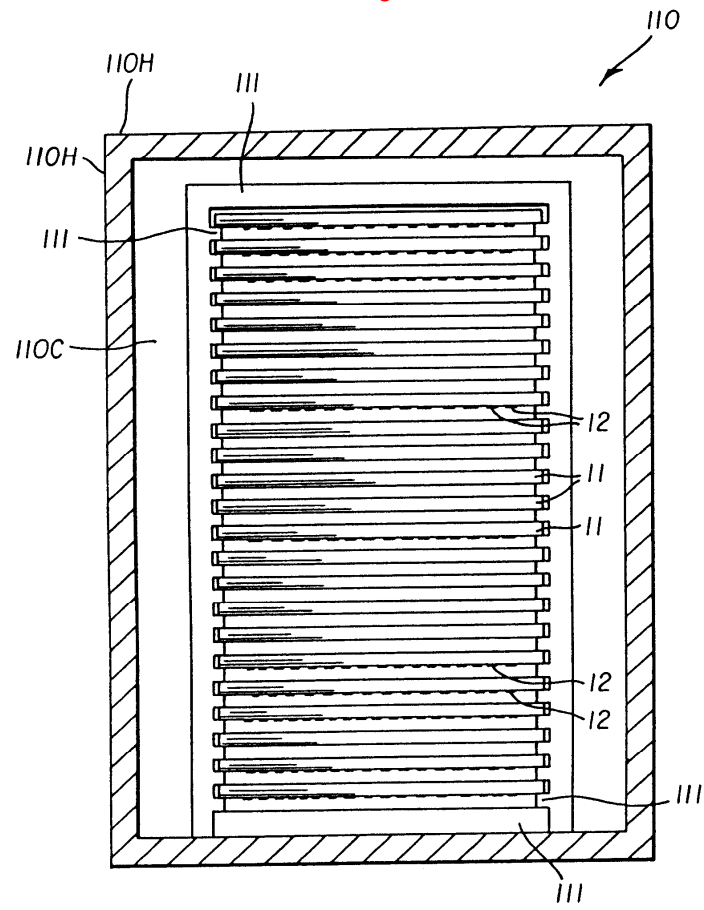

9

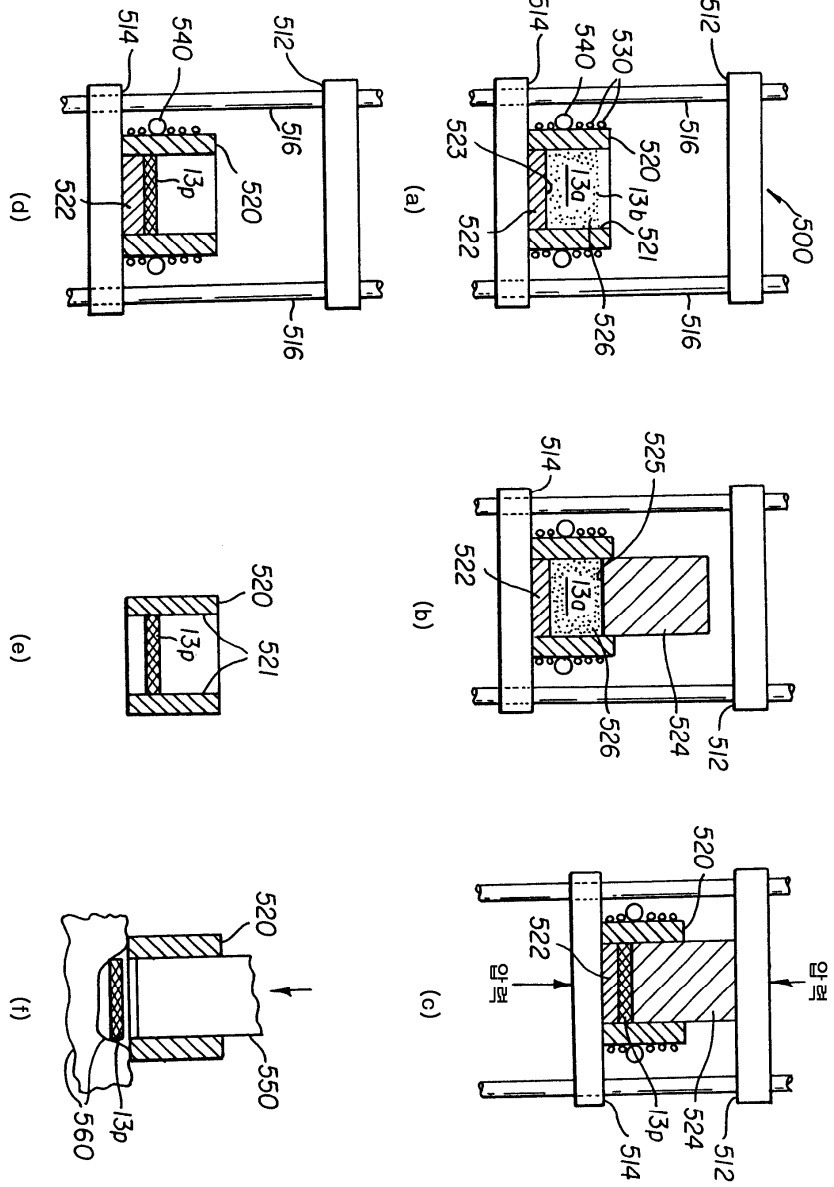

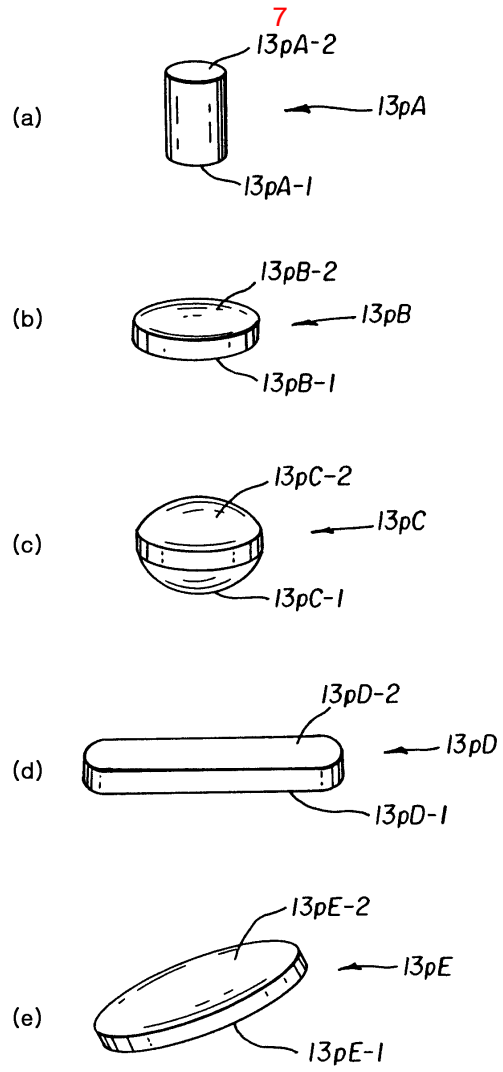

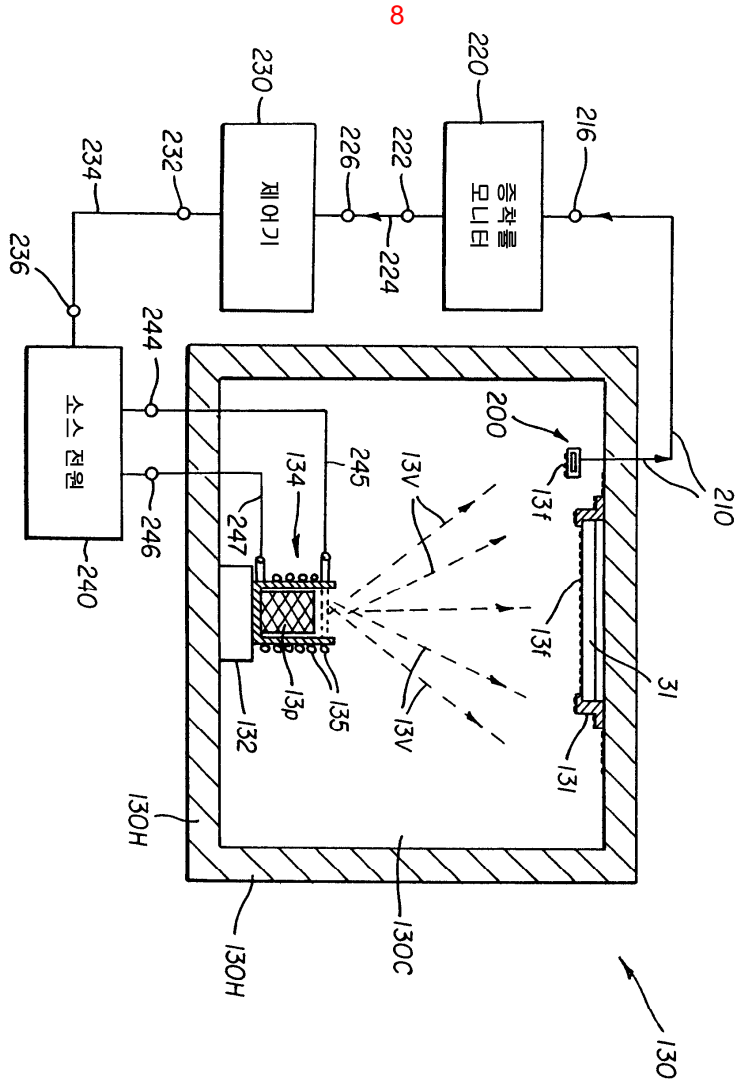

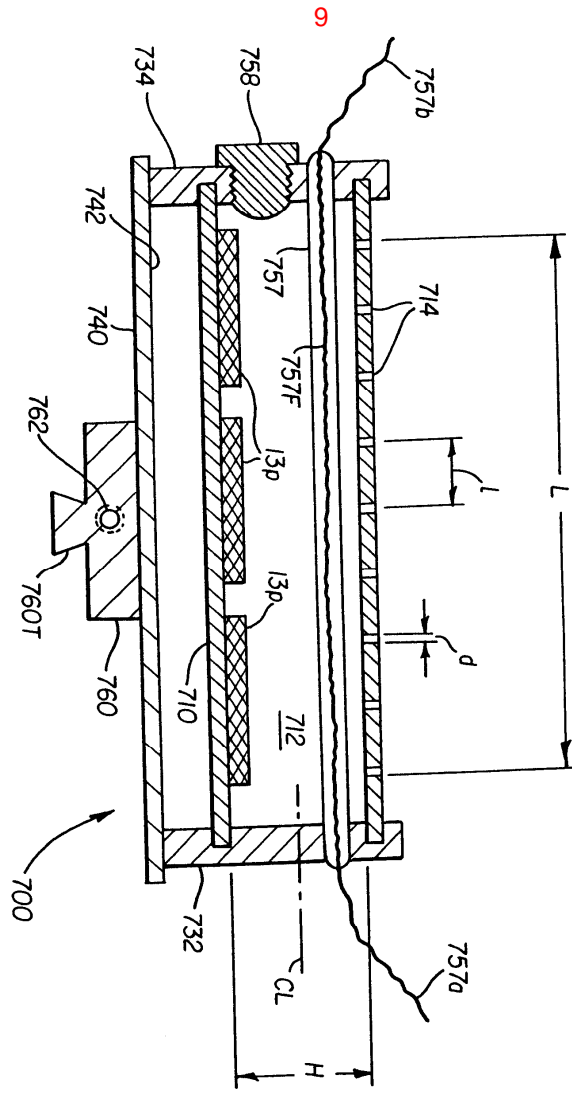

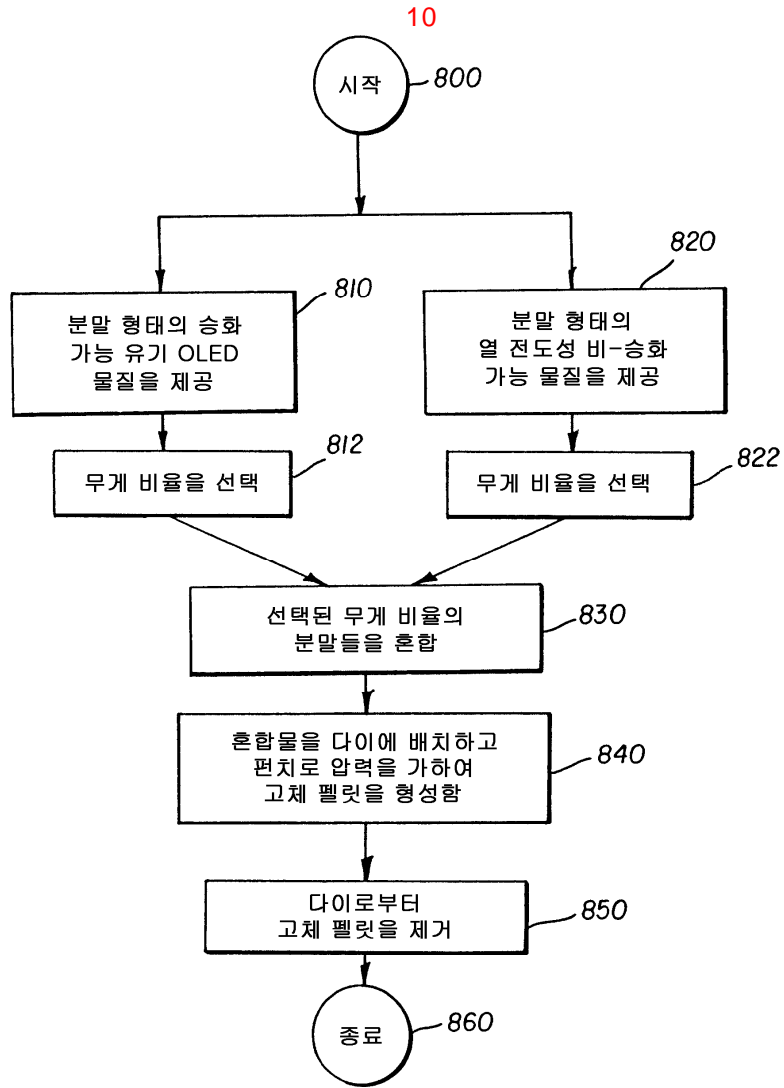

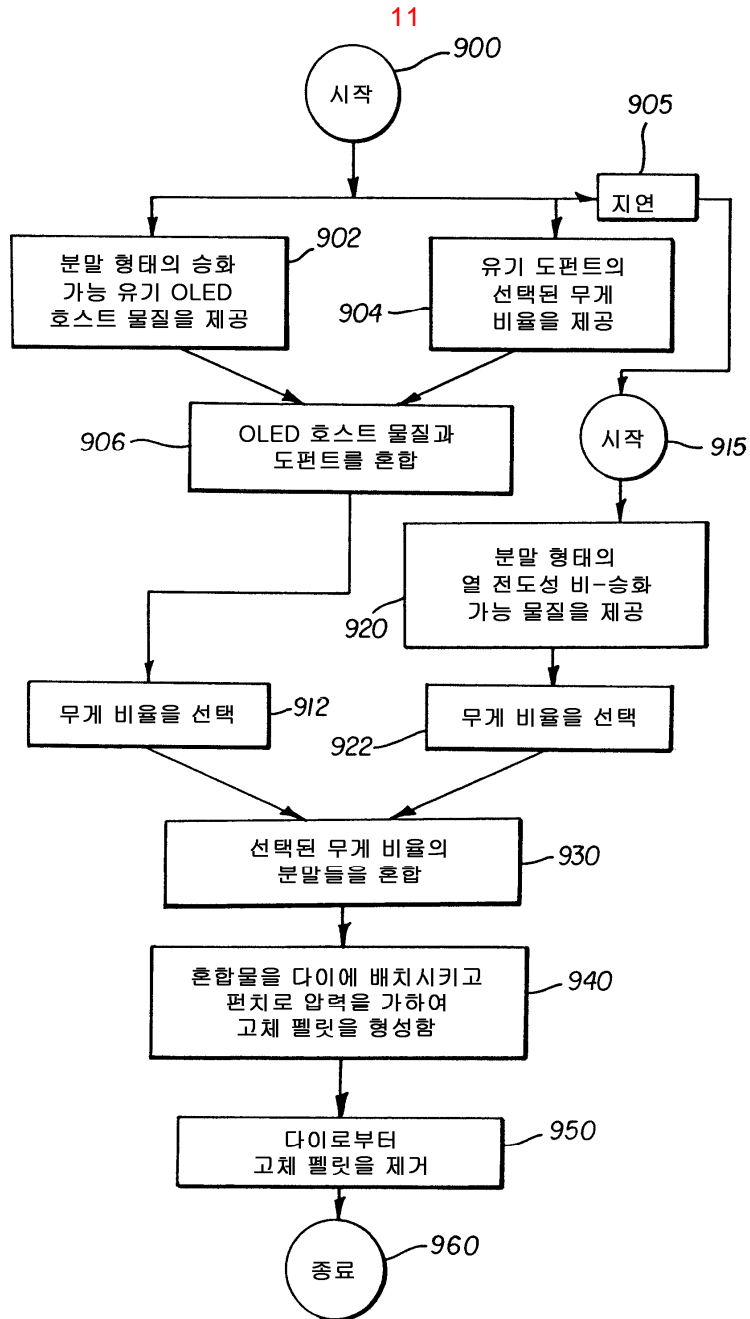

专利名称(译)	由有机材料制备有机层的方法和使用粒料的方法		
公开(公告)号	<a href="#">KR1020030068051A</a>	公开(公告)日	2003-08-19
申请号	KR1020030008236	申请日	2003-02-10
[标]申请(专利权)人(译)	伊斯曼柯达公司		
申请(专利权)人(译)	柯达公司针		
当前申请(专利权)人(译)	柯达公司针		
[标]发明人	GHOSH SYAMALKUMAR CARLTON DONNBURTON HATWAR TUKARAMKISAN 하트워투카람키산 VANSLYKE STEVENARLAND		
发明人	고쉬샤말쿠마르 칼튼돈버튼 하트워투카람키산 반슬라이크스티븐알랜드		
IPC分类号	H01L51/40 H01L51/50 H05B33/10 C23C14/12 H01L51/56 H01L51/30 H01L51/00		
CPC分类号	H01L51/56 H01L51/0059 H01L51/001 H01L51/0081 C23C14/12		
代理人(译)	KIM, CHANG SE KIM, WON JOON		
优先权	10/073690 2002-02-11 US		
外部链接	<a href="#">Espacenet</a>		

摘要(译)

由基板上的有机材料制造有机层以形成有机发光器件的一部分的方法包括提供粉末形式的可升华有机材料并提供导热和非导电有机材料。形成可升华的有机材料粉末和导热和不可升华的陶瓷材料粉末的混合物;将混合物置于模具中并使用冲头对加热的混合物施加足够的压力以形成粉末混合物导致固体颗粒絮凝,并从模具中取出颗粒。 3

