

가

1

2 1

3, 4 5

가

6

1

(2)

(EL)

(1)

(1)

2

(coumarin)

PPV{

(P -

(phenylene vinylene))}

PPV -

(3)

(2)

(4),

(5)

(LED)

(4)

(3)

(ITO)

(4)

(3)

(5)

(4,5)

(3)

, 2 (two - component)

(6)

(2)

(4' 5') 가

(lid)(7)

(rim)

(7)

가

(4' 5')

(7)

가 (7)

(6)

(register)

(6)

(6)

가

(2)

(7)

(

25

80

8)

가

가

(8)

, 2

(7')

(hole)(9)

(9)

가

3, 4 5

(7")

가

3

(7")

(11)

4

(10)

(10)

3 4

(11)

(11)

가

(7")

(6)가,

(2)

/

(11)

(7")

(10)

(7") EL

(-)

가

6 , 가 , 25 80 t=10 , 가 (, t=10 t ≅
 12) , 가 (, t ≅
 t ≅ 12 t ≅ 15) 가 .

: 가 , (10)

(8)

가 , 가

가 , 가 , () , -

가 가 가 () 가 .
(10) (7")

() 가 (the other end) . 4 , (8)
 가 (8) (10) 2 (recess)(12) , (12)
 (2) , (8) (10) ,

가, (7") , 2 () 가, ()

(getter)

() , () 가 ,
() (bridge)

(communication)

가 EL

()

()

8

EL

가가

, 2

2

가

L) , , , EL , , 2 , 2 (E)
가 .

(57)

1.

(cavity)(8) (6) 2 (1) , (3,4,5) , (2,7) , 2 (2,7) (11)
(10) (11) ,

2.

1 , (6) 가 () (10) ,

3.

2 , (12) (8) 가 () (10) ,
(8) ,

4.

1 3 () (10) 가 (2,7") , (11) () (11) ,

5.

1 4 (3,4,5)가
(2) (8), () (10) , ()
(7") ,

6.

(6) , 2 (2,7) (1) , (2,7) 가 ,
(3,4,5) , (2,7) (11) (6) (8) ,
(2,7") 가 , (10) (2,7) (11) ,
(10) / (10) (8) (6) , 가 , 가가
() (10) (6) ,

7.

6 2) , (10) (6) (8) (1

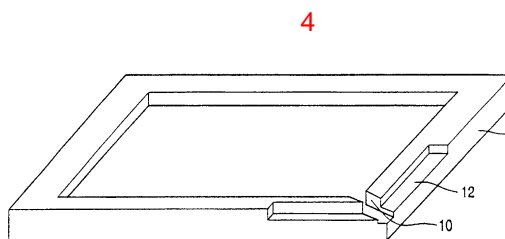
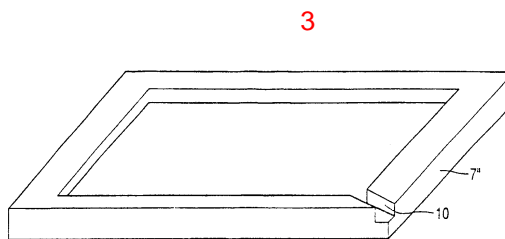
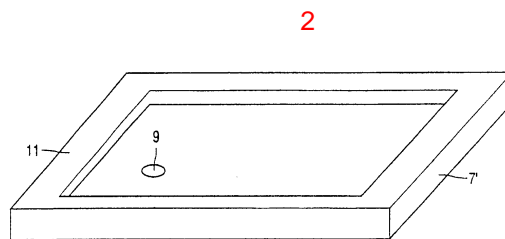
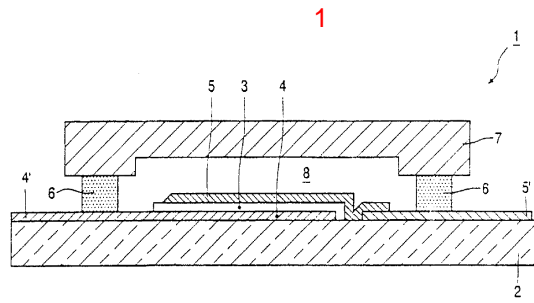

5

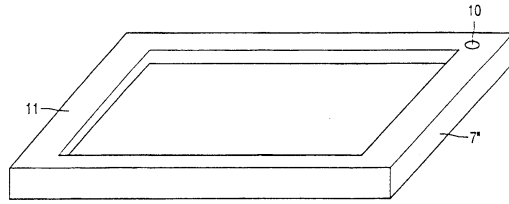

6

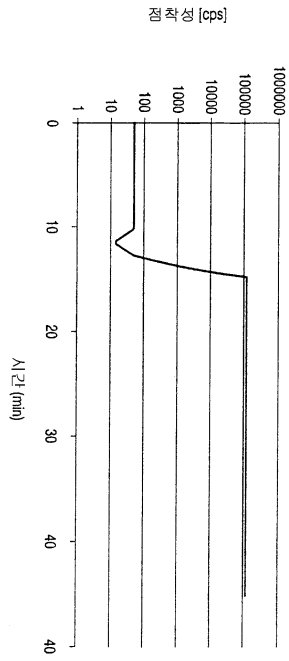

专利名称(译)	特别是诸如电致发光显示装置的装置及其制造方法		
公开(公告)号	KR1020020077473A	公开(公告)日	2002-10-11
申请号	KR1020027010693	申请日	2001-12-06
[标]申请(专利权)人(译)	皇家飞利浦电子股份有限公司		
申请(专利权)人(译)	科宁欣克利凯恩菲利普斯日元.V.		
当前申请(专利权)人(译)	科宁欣克利凯恩菲利普斯日元.V.		
[标]发明人	LIEDENBAUM COEN T H F		
发明人	LIEDENBAUM,COEN,T.,H.,F.		
IPC分类号	H05B33/04 H01L51/50 H01L51/52 H05B33/10		
CPC分类号	H01L51/524 H01L51/5246		
代理人(译)	MOON , KYOUNG金		
优先权	2000204653 2000-12-20 EP		
外部链接	Espacenet		

摘要(译)

本发明涉及一种EL显示装置，包括2个或更多个限制用于接收该装置的腔的部件，尤其是至少一个像电致发光元件的装置;用存在于多于2个部分的界面中的热固性粘合剂密封。至少一个通道设置在边界面上。

