

(19)
(12)

(KR)
(A)

(51) 。 Int. Cl. 7
H01L 29/78

(11)
(43)

2003-0039309
2003 05 17

(21) 10-2002-0069401
(22) 2002 11 09

(30) JP-P-2001-00345273 2001 11 09 (JP)

(71) 가 가
가 가 398

(72) 가 가 398가 가

(74)

:

(54) , , ,

가 가 가 , OLED 가
. , .
가 . , , .

2

, , , , , , ,

1

,

2

,

3

,

4(A) 4(B) ,
5 ,
6(A) 6(B) ,
7(A) ,
7(B) ,
8(A) 8(C) ,
9(A) 9(C) ,
10(A) 10(C) ,
11(A) 11(D) ,
12(A) 12(D) ,
13(A) 13(D) ,
14(A) 14(H) ,
15 ,
16 ,
17 ,
18(A) 18(B) TFT 3 (node) .

*

*

101: 102:
103: 104:
105: 200:
201: 202:
203:
204:

, OLED
가 . L = c(V)I(V) I(V) , c(V)

가 , OLED
가 . , 가

, OLED ,

AM OLED
가 . (TFT)

, , 가

, () , () ,

, () 가 ,

() 가

OLED ,

, .

가 가

, 가

, TFT , TFT 가

가 , (multi-drain)

3

, 가 , 3 ,

가 3 ,

, .

(, TFT)

(101) 가 (103) p 가 (102)
n 가 , ,
. .

3 (node) 가 , (101) 1 ,
(101) (Pj) , (102) (101) 1 ,
2 (Si), (103) , (102) 1 ,
(4(A)), (101) (201) .

(102) (103) (102) (102) (102)
, 1 , 2 (Vi), (101) 2 , (105)
. (102)

(105) , OLED , (105)
) OLED EL , . OLED , FED , OLED , (105)
. OLED 가

, OLED (105) , ,
. (102) (102) p n , ,
. (102) 가 , .

, , OLED (105)
, , (luminescence) 가 , () .
, () , .

(103) (Ej) (103)
(102) , (Vi) .

(104)가 2 (Vi) , (102) (102)
, (104)가 2 (102) (102)

Vi) () (Vi) () ()
() (105) 가

, OLED
. OLED

2 (201) 가 (狀) 1 200 , 203
2 가 , 204 202 , 203

1 (202), (203) ()
204)가 , (203) (202), (

(203) , (103)(1) (204) (201) (202),
(204) , (203)

(202), (203), (204)
TFT (203), (204) 가 (202),
) FPC (200) (200) (

1 (P1~Py), (200) (E1~Ey), (S1~Sx), (V1~Vx), (S1~Sx), (V1~Vx)
 가 (P1~Py), (E1~Ey)
 (V1~Vx) (V1~Vx)
 가 (Ta), 3 (Td), 4 (Te) (Tu)
 가 (ON) ON 가 (OFF) OFF
 3 (201) (Ta), (Td), (Te) (Tu) (Tu) (Te) (Tu)
) (Ta) (Te) (Td), (Tu) (Te) (Ta)
 가 (Tu) 4(B) (Td) 4(A) (201) (Ta) (Td) (201) (201) (Ta)
 가 가
 가 (Ta) (P1) (103) (101) (101)
 (102) (202) (S1~Sx) (201) (V1~Vx) 가 (101)
 (Ta) (201) 4(A) (101)가 (101)
 102) (P1) 1 (101) 가 1 (101)가 (101)
) n n (102) 1 가 (102) 1
 (102) 1 가 (Si) (201) (V1~Vx) (10)
 2) 1 (101), (102) 1 (104) (104)
 (102) 1 (101) (V_{GS}) (104)
 (102) 1 가
 (Ta) (102) 1 (W) V_{GS} (L) V_{TH} μ C_o (102) W/L
 (I_{dn})

$$I_{dn} = \mu C_o W/L (V_{GS} - V_{TH})^2 / 2$$

μ, Co, W/L, V_{TH} V_{GS} I_{dn} μ, V_{TH} 가
 (102) 1 (I_{dn}) (I_{vd}) I_{dn}
 μ, V_{TH} (102) 1

01) (Td) (Ta) (Td) (P1) (P1) (E1) (1)
 (103) (Td) (E1)

4(B) (Td) (201) (102) (102)
 (Ta) V_{GS} 가 (104) (Td)
 (101) 가 1 가 2

(102) 2
 (I_{vd})

$-V_{TH})^2/2$, $I_{dn} = \mu C_o W/L(V_{GS} - V_{TH})^2/2$, $I_{dn} = \mu C_o W/L(V_{GS} - V_{TH})^2/2$
 $I_{dn} = \mu C_o W/L(V_{GS} - V_{TH})^2/2$, $I_{dn} = \mu C_o W/L(V_{GS} - V_{TH})^2/2$
 $I_{dn} = \mu C_o W/L(V_{GS} - V_{TH})^2/2$, $I_{dn} = \mu C_o W/L(V_{GS} - V_{TH})^2/2$
 (I_{dn}) μ, V_{TH}

μ, V_{TH} (102) 1 2 (102)
 가 , 1 2 μ, V_{TH}

(Td) (102) 2 (I_{dn}) (I_{vd})
 (Vi) 가 (102) 2 가 (105) (105) (105) (105)
 (105) (I_{dn})가 (105)

(I_{vd}) (102) 가 (102) 가 (102) 가 (102) 가

1 2 (I_{el}) 1
 (I_{vd}) (I_{el}) (16)

(I_{el}) (I_{vd}) (I_{el}) 가

(Ta) , 2 (Ta) (P2) , 2 (E2)
 (103) (S1~Sx) (V1~Vx) 2 (202) (201)
 (102) 가 (101)

, 2 (Ta) (Td) (Td)
 1 가 , 2 (Ta) (I_{vd})가 , 3
 (105)가 (Ta)

가 3 (Td) 4 (Ta) ,
 , 4 (Ta) , y (Td) 5 (Ta)

1, 1
 1 (Td) (像) 60 Hz
 (103)가 가 (103)가
 가
 (204)
 1 (E1) (10 가
 3) (V1~Vx) (Te)가 (103) (102) (105) 가 (105)
 (105)
 (Te) (Te) 1 (Tu) 2 E2 2, 1
 (P2) (E2) 2 (101) (103)가 (定) (V1~Vx)
 (103) (102) 가 (105) (102)
 (105) 가
 (Te) 2 E2 3 E3 (Tu) y
 (103) (Tu) 1 (Ta), (Td), (Te)
 (Te) (Tu) 1 (Tu)
 (Te) (Tu)
 (Ta) (Td) (105) (I_{vd})
 (202) (201) OLED 가 가 (I_{vd}) OLED
 (L) L = c(V)I(V) (I_{vd}) (I_{vd}) n I(V)
 (I_{vd}) n
 2 OLED
 가 () , RGB (sub)
 2 (102) 가
 가

15

(17)

(202)(1)

2 가

(2)

1

가

(, (,) 가)

2

2

2

(

2000-3590

32

(Ta) 2 (Td) 2

가 , 1

, n

. n

(Ta1~Tan) n

, n

(Td1~Tdn) n

1

, n

n

1

TFT

2001-257163

(Tam)(m 1~n) (Tem)

(Tum)

(Tdm)

(Tem)

(T

um) (Tu) . m

(Ta),

(Tam),

(Td),

(Tdm)

(Te),

(Tu)(

(sub-frame) SFm

(Te),

(SF)

(SF1~SFn)

SF1:SF2:.....:SFn = 2⁰:2¹:.....:2ⁿ⁻¹

가

, 1

1

1

1

가

(1)

(201) 1 (202) (202)
 가 (I_{vd}) (S1~Sx)
 (302) 5
 (402) 6(A) 6(B)
 7(A) 7(B)

b), (B)(302c) (302) (V/C (302a), (302d) 가 (302) 5 (A)(302
 (SP) (302a) (CLK), (SP)가 (CLK)
 (402a)
 (A)(302b)

c) (A)(302b) 가 , V/C (302d) 가 (B)(302c) (B)(302
 가 가
 가 (가 100%) (가 0%) 가
 가

6(B) , 6(A) (402) 6(A)
 (402b), (402c), (402d) 가 (402) (402a),
 (SP) (402a) (CLK), (SP)가 (CLK)
 (402a)
 (402b) (402c)

(402c) (402c) V/C

6(B) , (402c), (402d) (402c)
 (410) (402b)

6(B) (402c) (411)가 (411)
 (406) (402d) (402c)가 (402d)
 (411) 6(B) (411) (402d)가
 (411) (411)

2) (402d)가 (412) 6(A) 6(B) (41
 (I_{vd}) 가 (402d)가 (417) (417) 2
 (413, 414) , (416) , (415) 가

(Res) (414) (Res) (413) (413) (414) (416)
 가 , (413)가 가 가 (414)
 가 , (415) 가 (415)
 가 0 가 가
 (歸線)
 가
 7(B) (203) (204) 7(A)
) 7(A) (203) (203) 가 (203)
 , (203a), (203b) 가 가
 , (203b)
 가 (203) 가 (203a) (CLK) (SP)
 , (203b)
 (101) (101) , 1
 (101) (203b)
) 7(B) (204) (204) 가 (204)
 , (204a), (204b) 가 가
 , (204b)
 P)가 (204) 가 (204a) (CLK) (S)
 , (204b)
 1 (103) (103) , 1
 (103) (204b)
 ()
 (203) (204)
 1 2
 (2)
 8(C) 8(A) 8(A) B-B' 8(B) 8(A) 8(A) A-A' 8(C)
 (503) 가 (501) , (501) (504) , (502) , (502)

가 (505, 506, 507) 가 (503) (504) , p , n
 (505, 506, 507) (504) (504)
 (504) 가 (LDD)
 가 ()
 (501) (505, 506, 507) (502) (508)
 (508) (502) 8(A) 8(C) (505, 506, 507)
 (509, 510, 511) , (502) (50)
 5, 506, 507) , (505, 506, 507)
 (502) ,
 8(A) 8(C) (503) 가 (509, 510,
 511)
 8(A) 8(C) 가 3 , (509, 510, 511)
 , 가
 , (511) , (503) (511) , (509) (510)
 가 (511) (509) (510)
 가 , 3 , 2
 , 18(A) 18(B) 가 ,
 가 가 가
 , 1 2, 1
 (3)
 2 2 ,
 3 가 ,
 9(A) 9(C) 9(A) 9(A) 9(C) 9(A)
 , 9(B) 9(A) A-A'
 B-B'
 (601) , (602) , (602)
 (603a, 603b, 603c) 가 (603a, 603b, 603c) (60)
 , (613) (601)
 4a, 604b, 604c) , 가 (605, 606, 607, 612) 가
 , p , n
 (603a) (604a) (602) (603b)
 (604c) (604b) (602) (603c)
 (602)
 (605, 606, 607) (604a, 604b, 604c) , (612)
 (604a, 604b, 604c) (605, 606) 2
 (604a, 604b)가 , (606, 607) 2 (604b, 604c)가
 , (607, 605) 2 (604c, 604a)가

가 (LDD)

가 ()

(601) (605, 606, 607) (602) (608)

(608) (602) 9(A) 9(C) (605, 606, 607) (605)

(609, 610, 611) (602) (605, 606, 607)

(602)

9(A) 9(C) (603a, 603b, 603c) 가

(609, 610, 611)

9(A) 9(C) 3 (609, 610, 611)

가 가 가 3 3

가 가 18(B) 9(A)

1 2, 1 2

(4)

19(B) 10(A) 10(A) A-A' 10(C) 10(C) 10(A) 10(A) B-B'

(702) 가 (701) (703) 가 (701) (703) (702) (704) (704)

(702) (705, 706, 707) 가 708 (701) (704)

(705, 706, 707) (704)

(704) (LDD)

가 ()

(703) (705, 706, 707) (708) (708)

(705, 706, 707)

10(A) 10(C) (701) 가 (709, 710, 711) (709, 710, 711)

10(A) 10(C) 3 (709, 710, 711)

가 가

2

1 2, 1 3

(5)

11(A) 11(D) 12(A) 12(D)

(102) 2 (103) (101)

OLED

11(A) #7059 #1737
(5001)

(下地膜)(5002) CVD SiH₄, NH₃, N₂O
(5002a) 10~200 nm(50~100 nm) 가 SiH₄
(5002b) 50~200 nm(100~150 nm)
(5002) 2 2

, N₂O

(5005, 5006) (5005, 5006) 25~80 nm(30~
60 nm) (SiGe)

YAG

, YVO₄ 가
cm² (200~300 mJ/cm²) , YAG 300 Hz 100~400 mJ/
30~300 kHz , 300~600 mJ/cm² (2
mJ/cm²) , 100~1000 μm, , 400 μm 350~500
() 50~90%

, Ar , Kr , YAG , YVO₄ , YLF , YAIO₃
Cr, Nd, Er, Ho, Ce, Co, Ti Tm , Ti:
가 YAG, YVO₄ , YLF, YAIO₃
, 1 μm

2 2 ~ 4 가
VO₄ (532 nm) 3 (355 nm) , Nd:YVO₄ (1064 nm) Y
10 W YVO₄

cm² (0.1~10 MW/cm²)가 , 10~2000 cm/s 0.01~100 MW/

VD (5005, 5006) 40~150 nm (5007) (5007) C

120 nm (5007)

40 Pa, 300 400 CVD TEOS(Tetraethyl Orthosilicate) 0.5 0.8 W/cm²
 (13.56 MHz) 400 500

00 nm (5007) 1 (5008) Ta 50~100 nm 1 (5008) 2 (5009) W 100~3

Ta Ta Ar (相) Ta Xe Kr 가 , Ar 20 μ cm
 Ta Ta Ta Ta 가 180 μ cm 10~50 nm

W W 6 (WF₆)
 CVD 가 W 20 μ cm W 가 가 가 (氣相)
) 99.9999% W 99.99% W 9~20 μ cm

a, W, Ti, Mo, Al, Cu 1 (5008) Ta, 2 (5009) W , T

9) W 1 (5008) 1 (5008) 1 (TaN) 2 (TaN) 2 (5009) Al 2 (5009) Cu
 1 (5008) (TaN) 2 (5009) Cu

(5010) ICP(Inductively Coupled Plasma:) 1 가 CF₄ Cl₂
 1 Pa () 100 W 500 W RF(13.56 MHz) RF(13.56 MHz) Ta
 가 . CF₄ Cl₂ W Ta

1 2 가 15 45° 가
 , 10~20% 가
 . W 2~4(3) ,

20~50 nm 1 (5013, 5014)(1 (5013a, 5014a) 2 (5013b, 5014b))
 (5007) 1 (5013, 5014) 20~50 nm

1 n 가 1 × 10¹³ 5 × 10¹⁴ /cm² , 가
 60 100 keV . n 15
 , (P) (As) 가 , (P) . (5013, 5014) n
 (5017, 5018) 1 × 10²⁰ ~ 1 × 10²¹ /cm³ n (5017, 5018) . 1

가 .(11(B))

11(C) 2 가
 CF₄ Cl₂ O₂ W 2 2 가
 (5028, 5029)(1 (5028a, 5029a) 2 (5028b, 5029b)) . 2 (5007)
 2 (5028, 5029) 20~50 nm

W Ta CF₄ Cl₂ 가 (種)
 , W Ta WF₆ , W
 WCl₅ , TaF₅ , TaCl₅ 가 , CF₄ Cl₂ O₂ 가 CO F가 , T
 Ta , O₂ 가 , CF₄ O₂ 가 , O₂ 가 ,
 F F가 F , Ta W , Ta ,
 a F가 Ta , W Ta , W Ta
 , 11(D) , 2 , 1 , 가 70~120 k
 eV , 1 x 10¹³ /cm² , 11(B) 1
 , 2 (5028, 5029)
 3 , 1 (5028a, 5029a) 가 가 ,
 28a, 5029a) (5034, 5035) 3 (5034, 5035) 가 (P) 1 (50
 가 (5028a, 5029a) 가 (5028a, 5029a)
 가 ,
 , 12(A) , 3 가 CHF₆
 (RIE) , 3 (5028a, 5029a)
 (1 (5039a, 5040a) 2 (5039b, 5040b)) 3 (5039, 5040)
 (5039, 5040) 20~50 nm (5007) 3
 3 , 3 (5034, 5035) 1 (5039a, 5040a) 3
 (5034a, 5035a) , 1 3 (5034b, 5035b)
 , 12(B) , p TFT (5005) 1
 4 (5049~5054) , 3 (5040b)
 (5200) , n TFT (5006)
 (B₂H₆) , 가 2 x 10²⁰ ~ 2 x 10²¹
 21 /cm² 가
 (5039, 5040) 3
 (5200) , 가
 (RTA) , 가 1 ppm , 0.1 ppm
 4 가 400~700 , 3 500 600 (5039, 5040) 가 500
 ())
 , , 0.01~100 MW/cm² (가 0.01~10 MW/cm²
) 가
 , 3~100% 300~450 1~12 가 ,
 ()
 , 12(C) , 1 (5055) 100~200 nm

1 (5055), 2 (5056), (5062), (5055), 2 (5056), (5062), (5057), (5064), 2 (5056), (5059~5062), 1 (5059~5062)

2 (5056), BCB() , 2 (5056) 가 , TFT 1~5 μm(2~4 μm) , n (5017) p (5049, 5054)

Ti 150 nm () (5059~5062) 3 Ti 100 nm, Ti 300 nm, (5064) (ZnO) (5062) (5064) ITO 110 nm (5064) 2~20% (12(A))

12(D) (5064) () 500 nm (5065) 3 가 가 가

(5066) (MgAg) (5067) (5066) 80~200 nm(100~120 nm), (5067) 180~300 nm(200~250 nm)

RGB 3 (: CCM) () RGB (5066) 4 (5067) (5067) MgAg (5066) (5068) 300 nm (5068)

12(D) 가

가 . , , Ni TFT 가 가 .
 10 MHz
 CMOS n TFT , , TFT
 , n TFT , , LDD (L_{ov}), LDD (L_o
 FF)
 , CMOS p TFT , n TFT 가 LDD LDD
 가 .
 , CMOS 가 LDD , CMOS n TFT
 가 CMOS 가 , CMOS n TFT L_{ov} 가
 , 12(D) ,) (材) () 가 가
 , , ()
 , 가 (FPC) 가
 , , ,
 가 .
 1 2, 1 4 .

(6)

OLED , OLED 13(A) 13(C)
 13(A) 가 , 13(C) 13(A) B-B' , 13(B)
) 13(A) A-A'
 (4001) (4002), (4003), (4
 004a, 4004b) (4009)가 , (4002), (4003),
 (4004a, 4004b) (4008)가 , (4
 002), (4003), (4004a, 4004b) (4001),
 (4009), (4008) . 4210 ,
 , (4001) (4002), (4003),
 (4004a, 4004b) TFT 가 , 13(B) (4010)
 (4003) TFT, , TFT(4201)(n TFT p TFT 1

) (4002) (4202) .
 , TFT(4201) p TFT n TFT가 ,
 (103)(13) n TFT가 .
 TFT(4201) (4202) () (4031) , (42 (42
 02) nction)가 () (4203) . (4203) , (work fu
 , , , , 가
 , (4203) (4302) , (4302) (4203)
 . (4203) (4204) . (4204) (4204)
 , 가 . , 가
 (4204) , , , . , .
 가 가 .
 (4204) () (4205) , , (4205) (420
 4) 가 , (cluster tool)) (4205) (4204) (420
 . 가 . () ,
 , () (4203), (4204) (4205) (4303)가
 (4303) , (4303) (4302) (4209) . (4209)
 4005a (4005a) (4009) (4001) , (4202) (4300) FPC(4006)
 FPC (4301) .
 (4008) , , () , FVP() , ()) (MyI
 ar) , , , (FRP) , FVP(, (foil) PVF)
 , , , . , .
 , (4103) , , , , PVB() EVA
 (, PVC()) , , , , .
 , (4103) () ,
 (4008) (4001) (4007) , (420 (420
 7) . , (4207) (4007) , (420
 8) (4207) (4007) . , (4207)
 (4208) (4207)
 (4303) .
 13(C) , (4203) , (4005a) (4
 230a) .

(8)

OLED

가

(), (DVD) () ()

14(A) 14(H)

14(A) (2001), (2002), (2003), (2004), (2005) 가 , T V ,

14(B) (2101), (2102), (2103), (2104), (2105), (2106) (2102)

14(C) (2201), (2202), (2203), (2204), (2205), (2206) (2203)

14(D) (2301), (2302), (2303), (2304), (2305) (2302)

14(E) (DVD) (2401), (2402), A(2403), B(2404), (DVD) (2405), (2406), (2407) A(2403), B(2404) , 가

14(F) () (2501), (2502), (2503) (2502)

14(G) (2601), (2602), (2603), (2604), (2605), (2606), (2607), (2608), (2609) (2602)

14(H) (2701), (2702), (2703), (2704), (2705), (2706), (2707), (2708) (2703) (2703)

가

가 , 가 가 CATV() 가 ,

(非)

5.

, ,
3 가 ,

3

6.

5 , 가 3 , 3 1

7.

5 , 가 , 3 3 1

8.

$n(n-2)$,
 n $n+1$ 가 ,
 n n
 $n+1$ n n

9.

8 , 가 $n+1$, $n+1$ 1

10.

8 , 가 $n+1$, $n+1$ 1

11.

, ,
3 가 ,

3

12.

11 , 가 3 , 3 1

11 13. , 3 1
가 , 3

14.

15.

14 16. , , 가

14 17. , , 가

14 18. , , 가

14 19. 가 , 가, OLED , ,

20. 가 가 ,
가 ,

가

20 21. , , 가

20 22. , , 가

가

가

33.

32

34.

32

35.

32

36.

가

가

가

37.

가

가

가

38.

37

39.

37

40.

37

41.

가

가

가

가

가

42.

가

가

가

3

3

43.

42

가

44.

42

가

45.

42

가

46.

42

가

가, OLED

47.

가

가

가

3

3

가

1

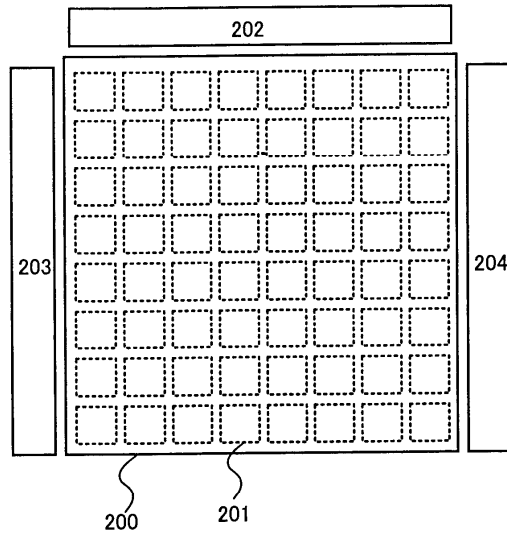

2

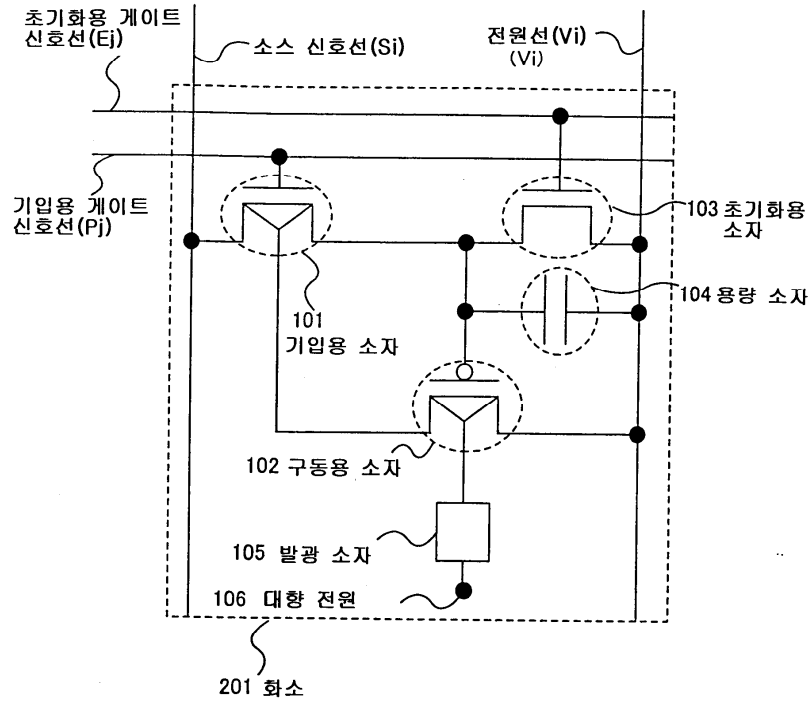

3

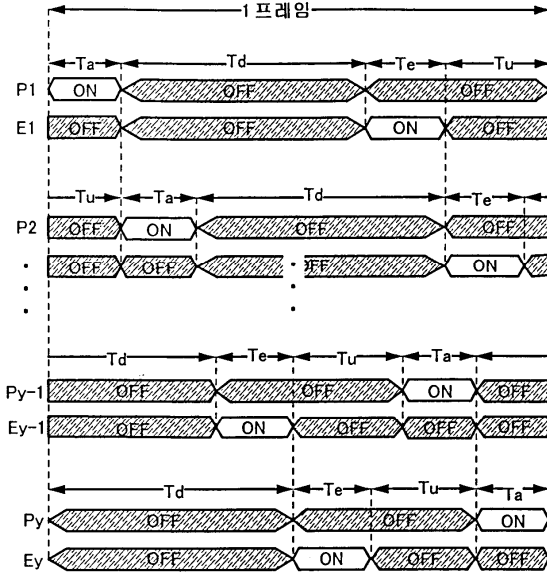

4

A 기입 기간 T_a

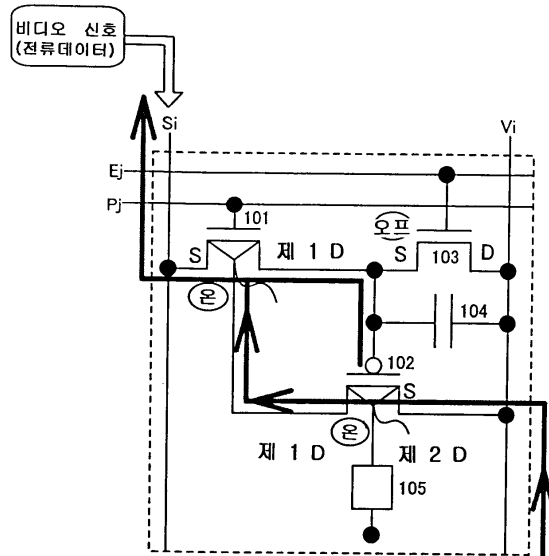

B 표시 기간 T_d

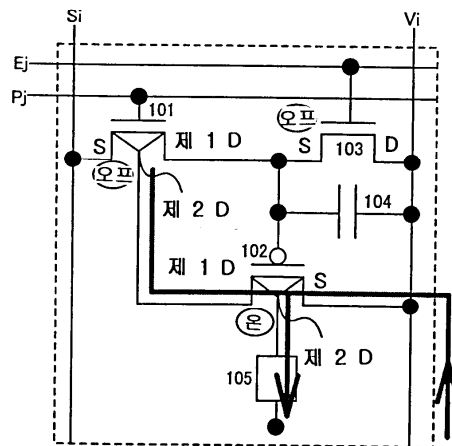

5

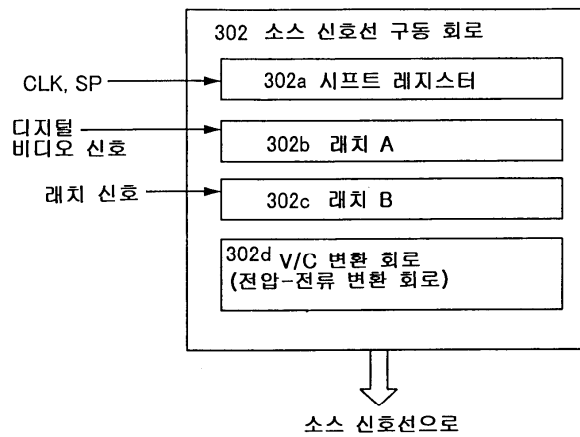

6

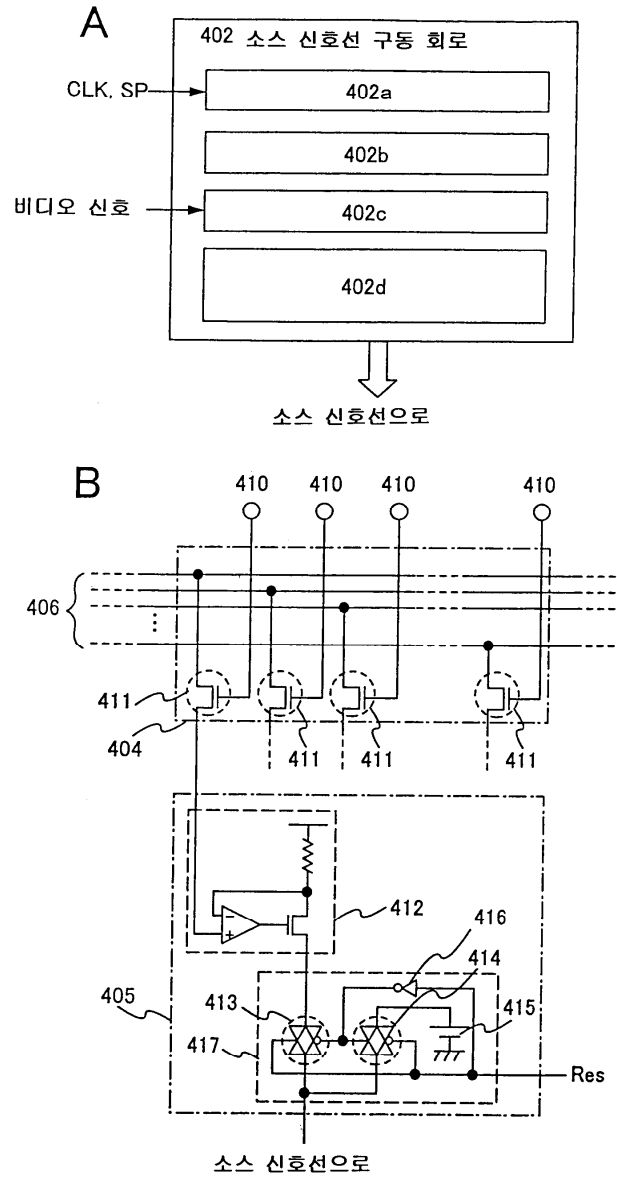

7

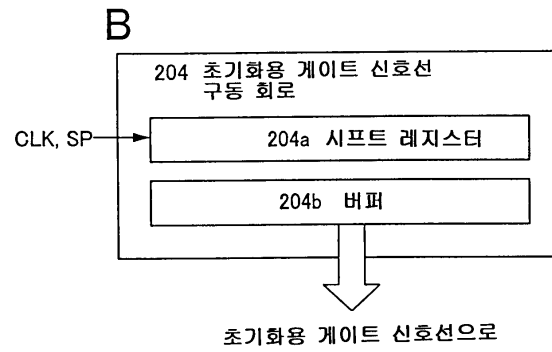

8

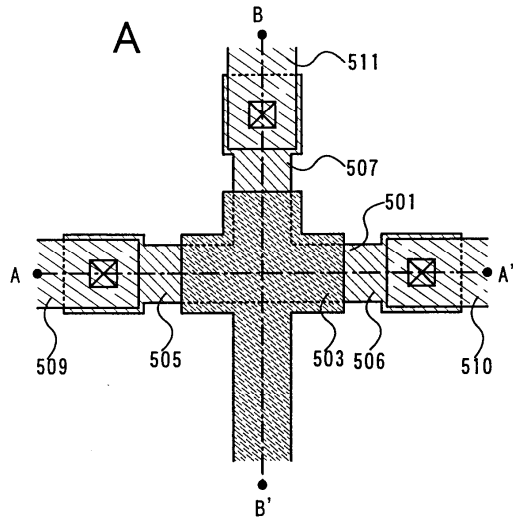

B

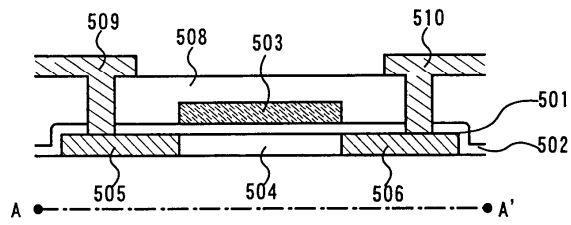

C

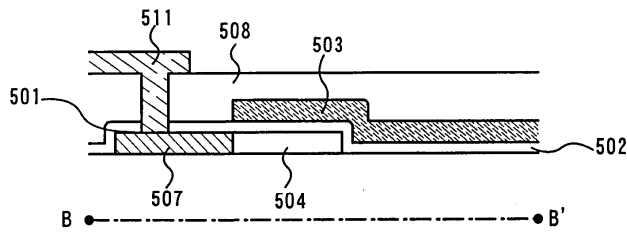

9

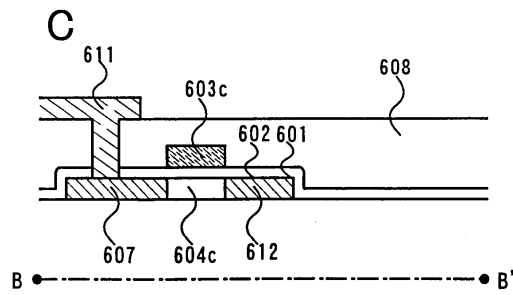
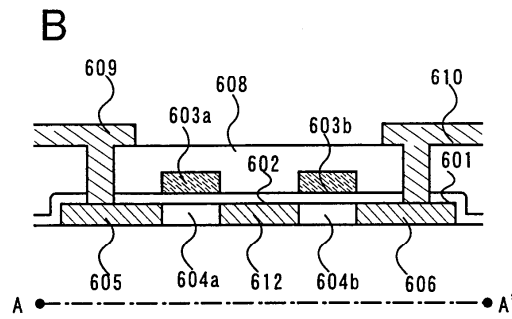
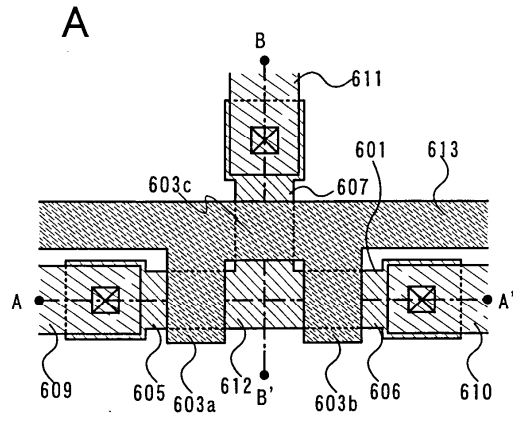

10

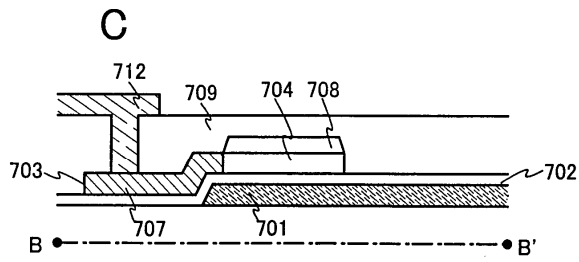
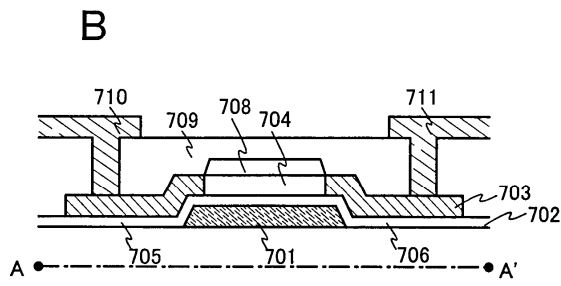
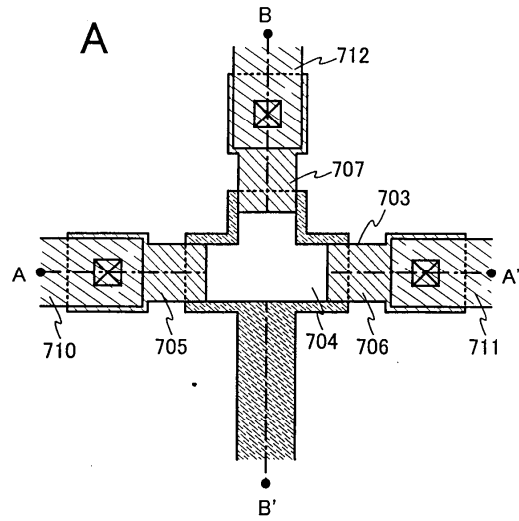

11

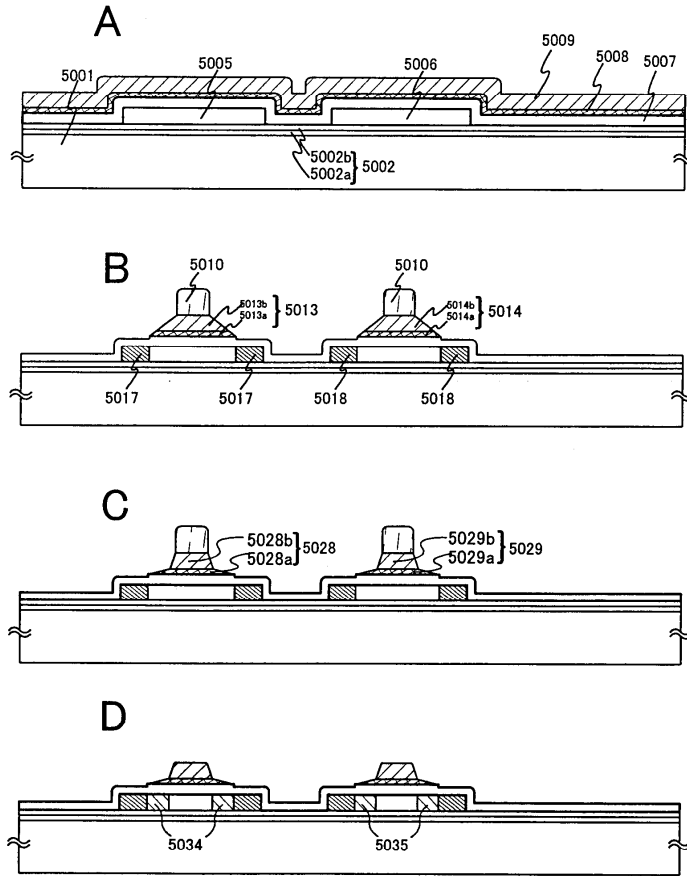

12

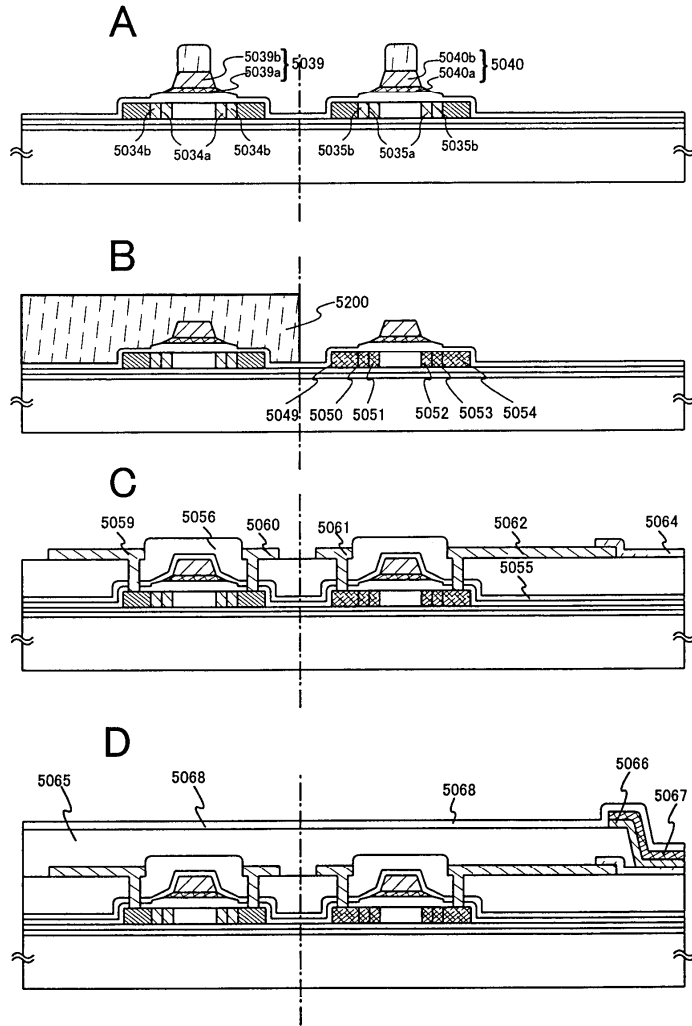

13

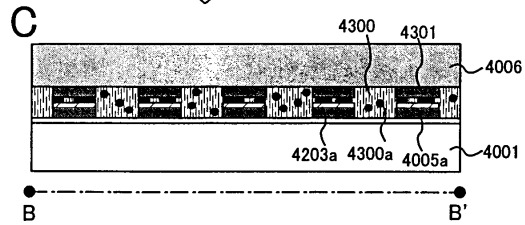
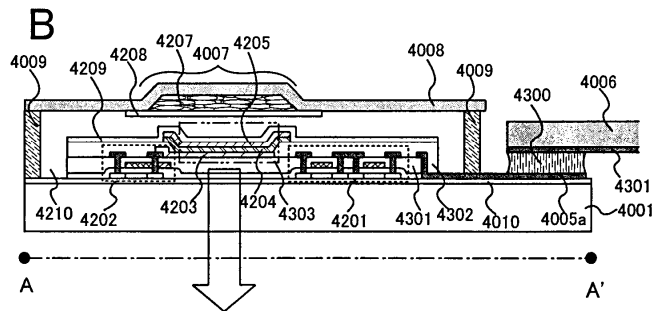
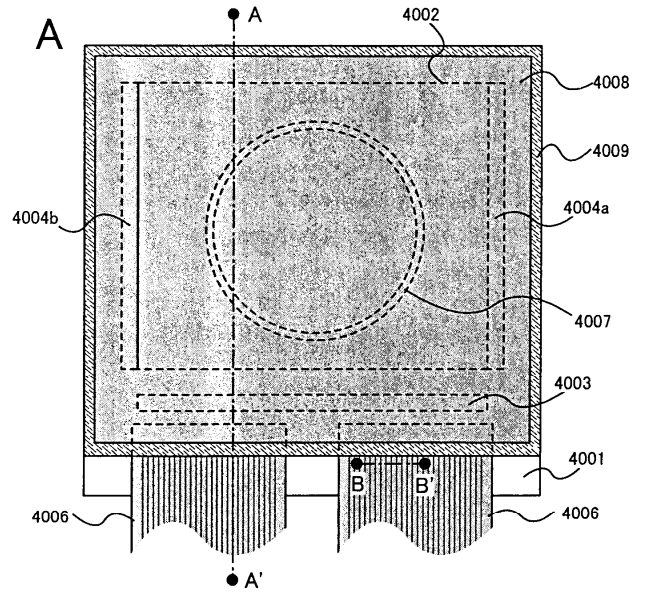

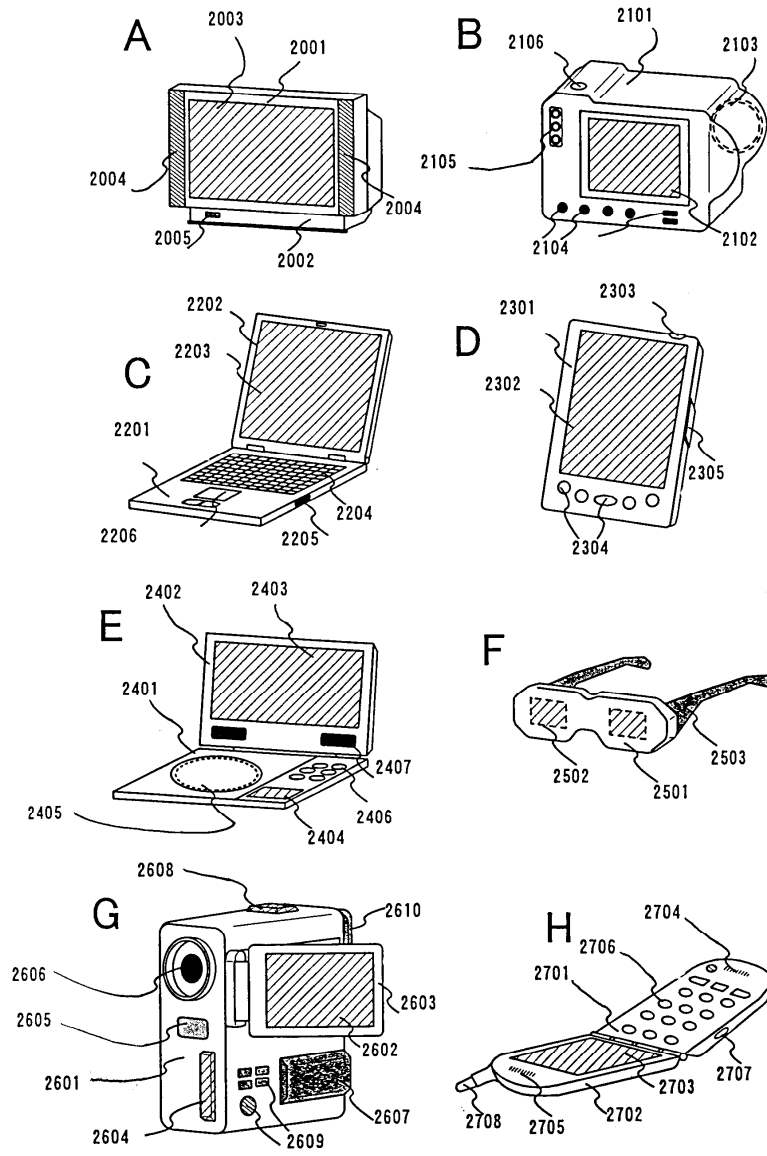

15

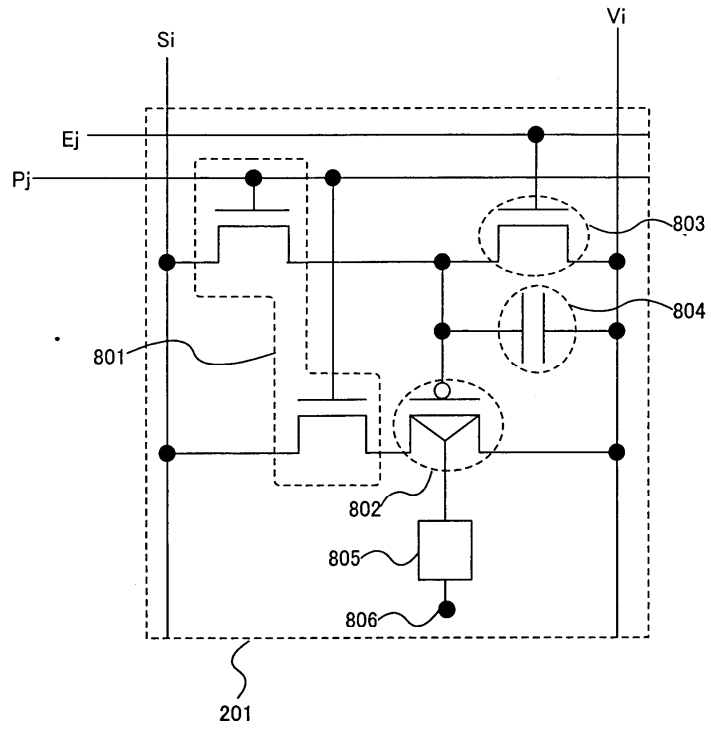

16

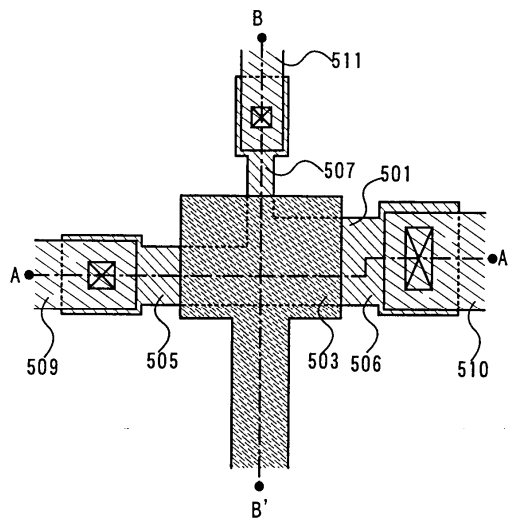

17

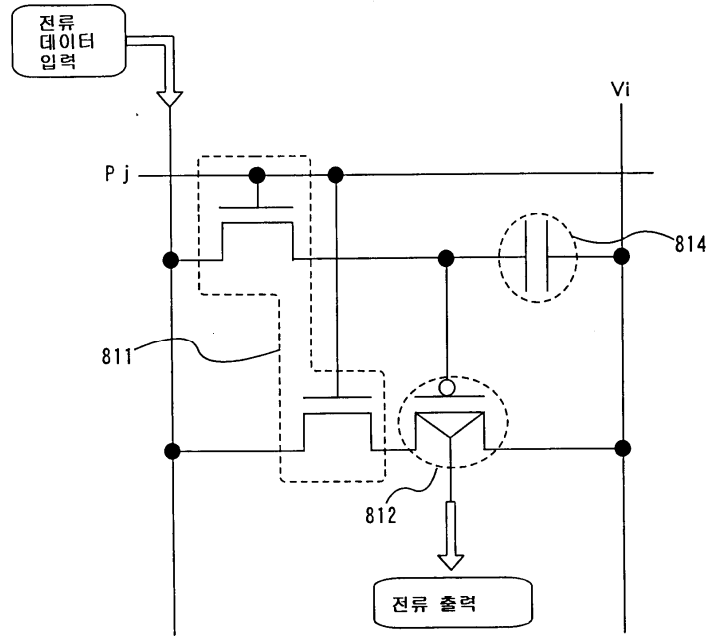

18

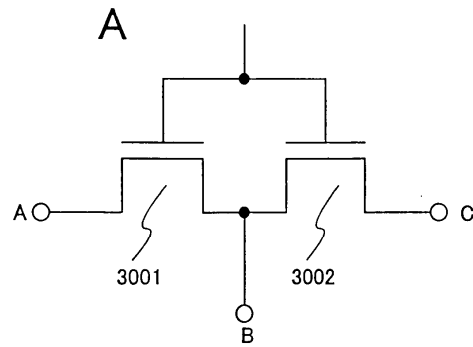

B

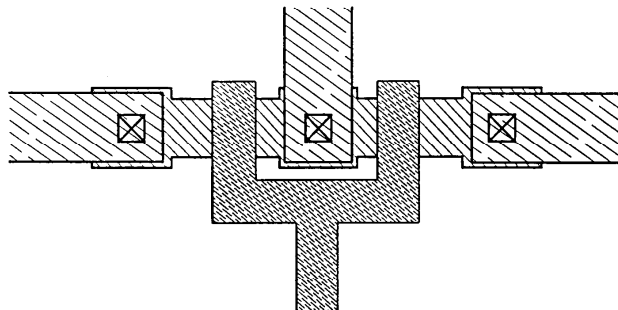

종래 기술

专利名称(译)	半导体器件，电路，显示器件，发光器件和电子器件		
公开(公告)号	KR1020030039309A	公开(公告)日	2003-05-17
申请号	KR1020020069401	申请日	2002-11-09
[标]申请(专利权)人(译)	株式会社半导体能源研究所		
申请(专利权)人(译)	株式会社绒布器肯kyusyo极限戴哦		
[标]发明人	INUKAI KAZUTAKA 이누카이카즈타카		
发明人	이누카이카즈타카		
IPC分类号	H01L51/50 G09F9/30 H01L21/336 H01L21/77 H01L21/8238 H01L21/84 H01L27/08 H01L27/092 H01L27/12 H01L27/32 H01L29/423 H01L29/49 H01L29/78 H01L29/786 H04N5/66		
CPC分类号	H01L27/1214 H01L27/1222 H01L27/1251 H01L27/3244 H01L29/42384 H01L29/4908 H01L29/66757 H01L29/78621 H01L29/78645 H01L29/78696 H01L2029/7863 H01L27/3262 H01L29/42312		
代理人(译)	黄的.		
优先权	2001345273 2001-11-09 JP		
其他公开文献	KR100950031B1		
外部链接	Espacenet		

摘要(译)

本发明实现了一种电流存储电路，该电流存储电路可以做得尺寸小，元件数量少，可以简化配置，可以低功耗工作，并且可以提高制造产量。此外，通过将该电流存储电路应用于诸如OLED显示装置的电流驱动型显示装置，可以提高显示装置的像素开口率，可以实现高可靠性，并且可以实现高性能。本发明的特征在于使用具有与具有多个漏极或源极的晶体管相同形状的新型半导体元件。当该半导体器件用于写入器件和驱动器件时，电流值，存储器和电流输出的写入只能由这两个半导体器件进行，因此，可以极大地方便小面积。2 指数方面 半导体器件，显示器件，发光器件，电子器件，写入器件，初始化器件，驱动器件

