

(19)
(12)

(KR)
(A)

(51) 。 Int. Cl.7

H05B 33/04

H05B 33/10

H05B 33/00

H05B 33/14

(11)

(43)

10-2004-0098030

2004 11 18

(21) 10-2004-7015337

(22) 2004 09 24

2004 09 24

(86) PCT/JP2003/003311

(87)

WO 2003/081954

(86) 2003 03 19

(87)

2003 10 02

(30) JP-P-2002-00082512 2002 03 25 (JP)

(71) 가 가 1 4 1

(72) 가 6 1 1 가 가

(74)

:

(54)

, 1 2

,

,

,

,

,

,

1

, , , , ,

가 (electroluminescence) 가 (EL 가)

EL 가 (excitio n) EL 가 (basic state) 3 2 (lamine) (carrier block lay er) 가

EL 가 (color) EL (silicon oxide) (dark spot) 가 EL (a single inorganic protective film) (barrier properties) (brightness) E (non-luminescent spo t) EL -

가 EL EL 가 1 2 1 2 가 ; ; ;

(silicon oxynitride) (silicon nitride) (chemical vapor deposition process) (sputter deposition) (plasma ch) (plasma poly merization deposition process) (polyparaxylyene)

,
,
,
, 1 , 2 , 1 2
, ;

가 ;

가 ,

1 EL
2 4 EL
5 EL EL
6 EL

EL , EL
2- (covering area) , EL
가 , 가 , EL
가 , EL , 가 , EL
, EL
1 EL (D) EL 1
(13) (, (10)), 2 (14
, , EL , 2 (15) (15) (가 ,)
, (16P)

(16S) (sealing film) 가 (16P) EL (D)
 EL (E), (10) (R1) (16S) (16P) (10) 가 (R2) (16P)
 (16S) (16P) (E)

2 EL (ITO ; indium-tin oxide)
 1 (13) (evaporated)
 (copper phthalocyanine) , TPD (triphenylamine derivative ;
) , Alq₃ (aluminum chelate complex ;)
 , Li₂O (lithium oxide ;)
 (14) (13) (14)
 2 (15)

3 , CVD (chemical vapor deposition) EL
 (polyparaxylylene film) (16P) , 1 (M1) (a fi
 rst opening mask M1) EL 가

4 , CVD (plasma chemical vapor deposition)
 (16P) (16S) , 2 (M2)
 (16P) (16S) 1 (M1) EL
 가 2 (M2) (aperture) 1 (M1)
 (16S) (16P) 가 가
 (16P) (16S) 가 가

(16P)
 (radicals) , (monomer) 가
 가 (vinyl group) (special polymerizing group)

가 (methane), (ethane), (propane), (butane),
 (pentane), (ethylene), (prophylene), (butene), (butadiene), (acetylene),
 (methyl acetylene) (hydrocarbome monomer);
 (hexamethyldisiloxane), (triethoxyvinylsilane), (polydimethylsiloxane),
 (tetramethoxysilane) (silicon monomer);
 (tetrafluoroethylene) (hydrogen fluoride monomer)

가 3- (crossed linked)
 , H/C=1.5 () 가 가
 가 가 가 가 가 가 가 가 가 가 가

CVD (polyparaxylylene polymerized film)
) , (chlorinated paraxylylene polymerized film)
 가 (low gas and steam permeability) 가
 가 (xylene resins)
 (Union Carbide Co.,Ltd in the U.S.A) N (Palylene N) (poly
 paraxylylene) , C (Palylene C) (polymonochloroparaxylylene) ,
 D (Palylene D) (polydichloroparaxylylene) C가 가
 가 N , SiN 2
 가 (a gas of a dimer)

ITO EL EL

(for comparison' sake),
 20 SCCM 가 0.9 Torr, RF 500 mW/cm², 가 13.56 MHz, 가 EL
 95% RH 가 EL , 0.5μm - , 60 . EL
 (test peice)

5 EL EL EL EL
 (10) (13; a low electrode) (1), (10)
 (15; a column electrode) (2)
 (in the form of a band) 가

) 가 EL (10) EL (picture display array
 (7; partition walls) (16P) 2 (15) (7) EL
 (R), (G), (B) EL

6 EL EL (10) (synt
 hetic resin) (22) EL 1
 EL (22) EL 가
 (6-naphthalate), (polyethylene terephthalate), -2 (polyethylene-2), 6-
 rsulfone), (polycarbonate), (polysulfone), (polyether ether ketone), (polyether
 (polyalylate), (fluororesin), (polypropylene) (polyphenoxyether),

(22) EL EL
 가 EL
 (22)

CVD

n film transistors) EL TFT (thi
 가 가 EL 가
 EL EL EL

(57)

1.

1

2

1

2

가

;

;

;

2.
1 ,

3.
1 2 ,

4.
1 3 ,

5.
1 4 ,

6.
1 5 ,

7.
6 ,

8.

, 1 , 2 , 1 가 2
, ;

가 ;

가

9.
8 ,

10.

8

9

8 11.

10

8 12.

11

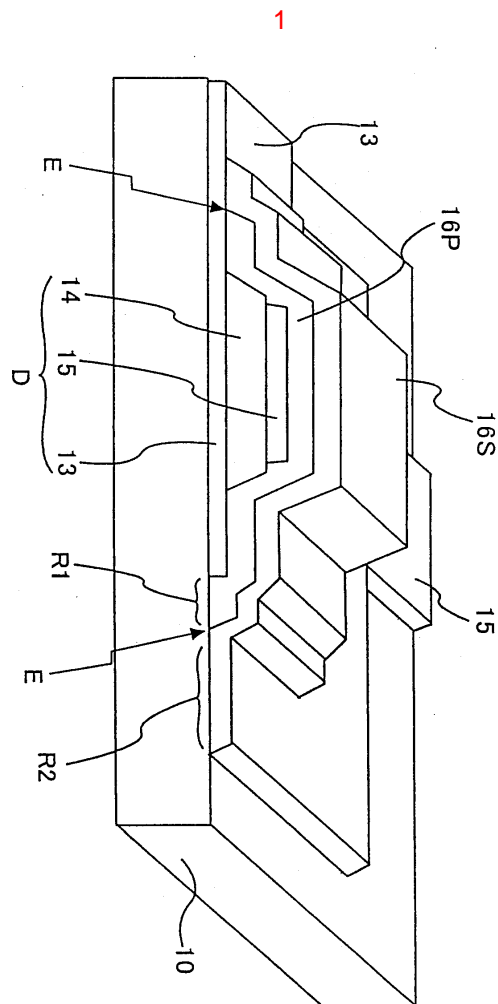

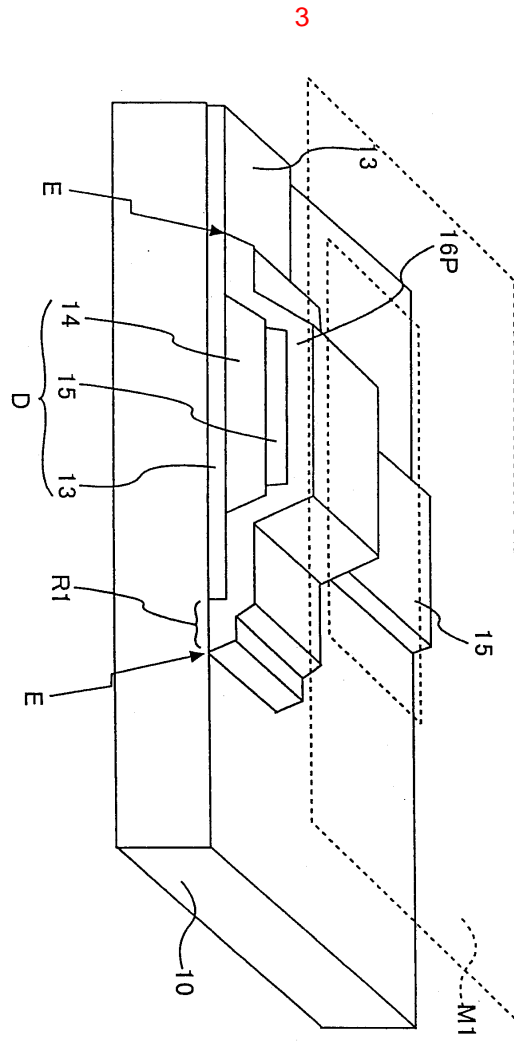

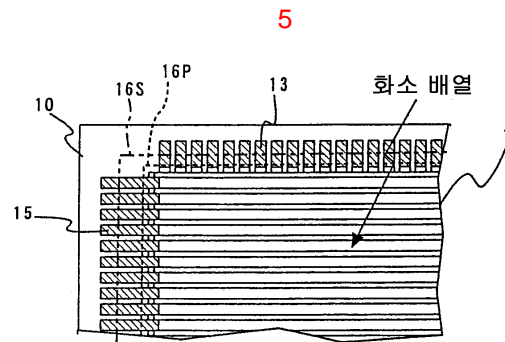
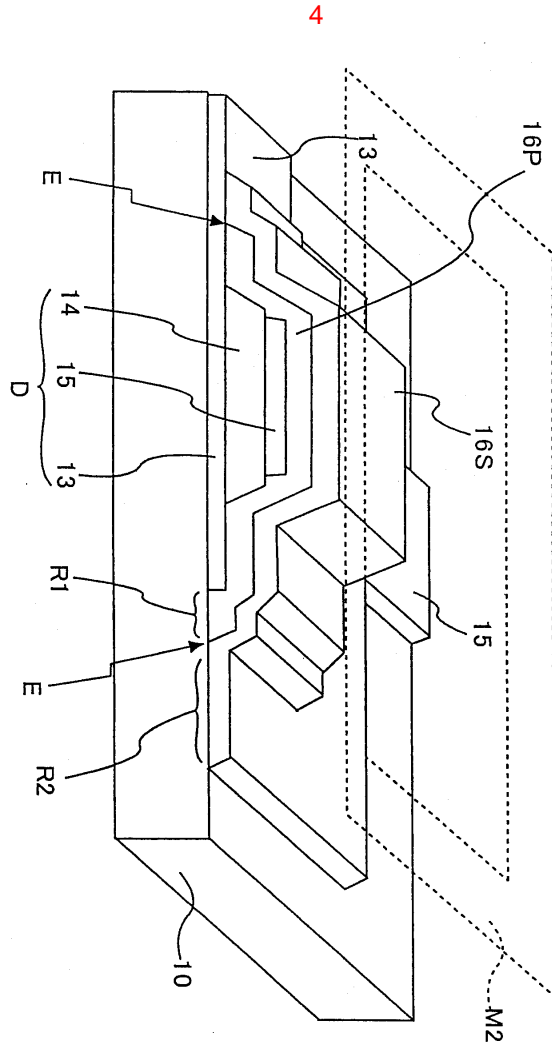

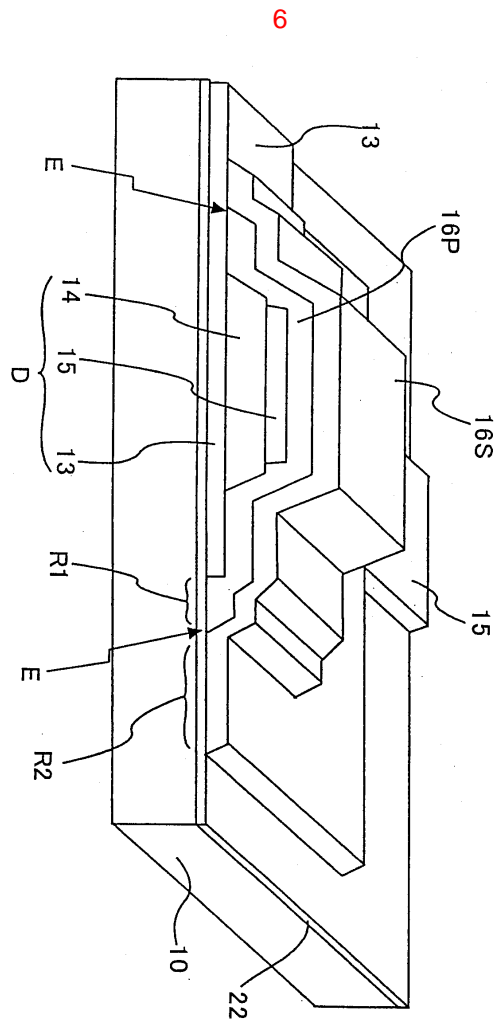

专利名称(译)	有机电致发光显示面板及其制造方法		
公开(公告)号	KR1020040098030A	公开(公告)日	2004-11-18
申请号	KR1020047015337	申请日	2003-03-19
[标]申请(专利权)人(译)	日本先锋公司		
申请(专利权)人(译)	先锋株式会社		
当前申请(专利权)人(译)	先锋株式会社		
[标]发明人	KUBOTA HIROFUMI		
发明人	KUBOTA,HIROFUMI		
IPC分类号	H05B33/04 H01L51/50 H05B33/14 H05B33/10 H01L51/52 H05B33/00		
CPC分类号	H01L51/5237 H01L51/5256		
代理人(译)	韩国专利公司		
优先权	2002082512 2002-03-25 JP		
其他公开文献	KR100683463B1		
外部链接	Espacenet		

摘要(译)

有机电致发光显示面板包括有机电致发光器件和支撑有机电致发光器件的基板。每个有机电致发光器件包括至少一种有机化合物的有机功能层，所述有机化合物保持在这些电极之间，同时包括第一和第二显示电极，以及发光层并形成层状结构。显示面板包括有机电致发光器件，覆盖其周围基板表面的高分子化合物膜，以及覆盖高分子化合物膜的无机阻挡膜及其边缘区域及其周围基板。有机电致发光器件，基板，发光层，显示面板，暗点，像素阵列。

