

(19)  
(12)

(KR)  
(B1)

(51) 。 Int. Cl.<sup>7</sup>  
H05B 33/26

(45)  
(11)  
(24)

2004 06 25  
10-0437673  
2004 06 16

(21) 10-2002-0010687  
(22) 2002 02 27

(65)  
(43)

10-2002-0070158  
2002 09 05

(30) JP-P-2001-00051410 2001 02 27 (JP)

(73) 575

(72) 5-7-1 ( )

5-7-1 ( )

5-7-1 ( )

5-7-1 ( )

(74)  
:

(54) ,

가 , (electroluminescence)  
,  
'In<sub>2-x</sub>Sn<sub>x</sub>O<sub>3-y</sub>'  
,  
(hygroscopicity) 가 가  
가 .

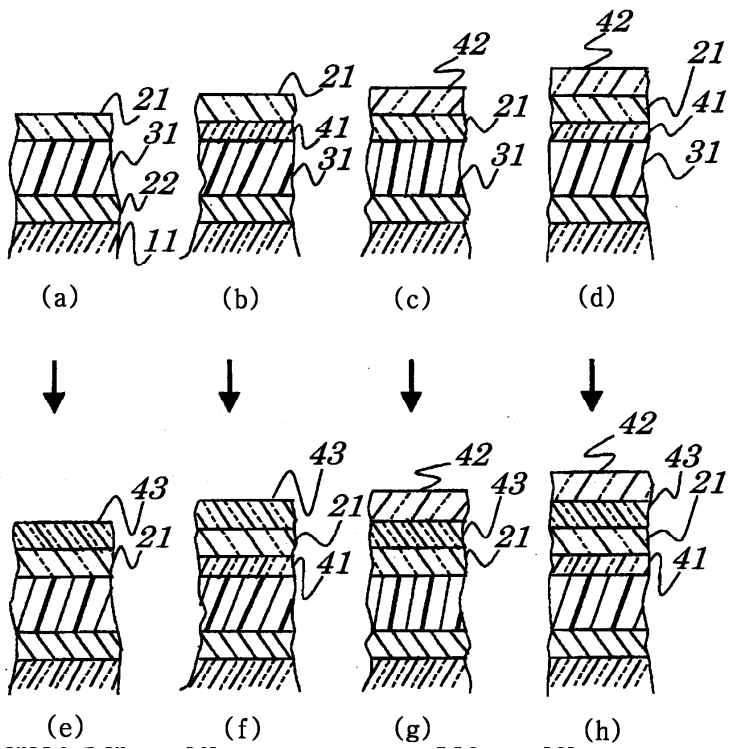

|     |     |   |
|-----|-----|---|
| 1a  | 1h  | 1 |
| 2a  | 2h  | 1 |
| 3a  | 3h  | 1 |
| 4a  | 4h  | 1 |
| 5a  | 5h  | 2 |
| 6a  | 6h  | 2 |
| 7a  | 7h  | 2 |
| 8a  | 8h  | 2 |
| 9a  | 9c  | 3 |
| 10a | 10c | 3 |
| 11a | 11c | 3 |
| 12a | 12c | 3 |
| 13a | 13c | 3 |
| 14a | 14c | 3 |
| 15a |     | 4 |
| 15b |     |   |
| 16a |     | 4 |
| 16b |     |   |
| 17a |     | 4 |
| 17b |     |   |
| 18a | 18c | 5 |
| 19a | 19c | 5 |
| 20a | 20c | 5 |
| 21a | 21c | 5 |
| 22a | 22c | 5 |

9b  
10b  
11b  
12b  
13b  
14b

18b  
19b  
20b  
21b  
22b

|          |     |    |     |     |     |       |
|----------|-----|----|-----|-----|-----|-------|
| 23a      | 23c | 5  |     | ,   | 23b | .     |
| 24a      | 24c | 5  |     | ,   | 24b | .     |
| 25a      | 25c | 5  |     | ,   | 25b | .     |
| 26a      |     | 6  |     |     |     | , 26b |
| 27a      |     | 6  |     |     |     | , 27b |
| 28a      |     | 6  |     |     |     | , 28b |
| 29a      |     | 7  |     |     |     |       |
| ,        | 29b | .  |     |     |     |       |
| 30a      |     | 8  |     | ,   | 30b | .     |
| 31       |     | 9  | 30a | 30b |     |       |
| 32       |     | 9  |     |     |     |       |
| 33       |     | 9  |     |     |     |       |
| 34       |     | 10 |     |     |     |       |
| 35       |     | 10 |     |     |     |       |
| 36       |     | 10 |     |     |     |       |
| 37       |     | 10 |     |     |     |       |
| 38       |     | 10 |     |     |     |       |
| 39       |     | 10 |     |     |     |       |
| 40       |     | 11 |     |     |     |       |
| 41       |     | 11 |     |     |     |       |
| 42       |     | 11 |     |     |     |       |
| 43       |     |    |     |     |     |       |
| 44       |     |    |     |     |     |       |
| 45       |     |    |     |     |     |       |
| 46       |     | 12 |     |     |     |       |
| 47       |     | 12 |     |     |     |       |
| 48       |     | 13 | (   | )   |     |       |
| 49       |     | 13 | (   | )   |     |       |
| 50       |     | 14 |     |     |     |       |
| 51a, 51b | 51c |    | 16  |     |     |       |
| 52a, 52b | 52c |    | 16  |     |     |       |
| 53a      | 53b |    | 16  |     |     |       |
| 54a      | 54b |    | 16  |     |     |       |
| 55a      | 55b |    | 16  |     |     |       |
| *        |     |    | *   |     |     |       |
| 11:      | 21: |    |     |     |     |       |
| 22:      | 31: |    |     |     |     |       |
| 33:      |     |    |     |     |     |       |

( )



EL . , 가 , EL  
가가 가 . ,

( ) , ,

EL . , ,

1 ,

0.05

2 ,

'In<sub>2-x</sub>Sn<sub>x</sub>O<sub>3-y</sub>'  
0.2 , 'y'

0.05

'In<sub>2-x</sub>Sn<sub>x</sub>O<sub>3-y</sub>'  
, 0.2 , 'y'

가

가

가

/

1

2

1

2

3

3

1

3

2

3

1

2

가

ON/OFF

4

3

ON/OFF

가

0.06

0.2

'In<sub>2-x</sub>Sn<sub>x</sub>O<sub>3-y</sub>'  
가 , 'y'

가

EL

EL



5a , (21) (31) (11) (23) (31) (31) ,  
 1a 1h (31) (21) (31) (21) (31) (21)  
 5b , (41) (21) (31) 5c , (42) 5a  
 5d , 5b (42) 5e ,  
 5a (21) (43) 5f, 5g 5h , 5b, 5c  
 5d (21) (43) 5e 5h ,  
 6a (43) (11) (21) (21) (33) , (32) ,  
 6a (23) (21) 1a 1h (32)  
 6b , (41) (33) (21) 6c , (42)  
 6a , 5a (21) (43) 6d , (42) 6b 6e  
 6c 6d (21) (43) 6f, 6g 6h , 6b,  
 7a (43) (11) (21) 6e 6h ,  
 7a , (11) (21) , (34) , (23)  
 7b 1a 1h (32) (21)  
 7b , (41) (34) (21) 7c , (42) 7a  
 7a (21) (42) 7d , (43) 7b 7e ,  
 7d (21) (43) (43) 7f, 7g 7h , 7b, 7c  
 8a (43) (11) (21) 7e 7h ,  
 8a , (11) (21) , (33) , (36) (35)  
 (23) , (36) (21) 1a  
 1h  
 8b , (41) (33) (21) 8c , (42)  
 8a , 8a (21) (43) 8d , (42) 8b 8e  
 8c 8d (21) (43) (43) 8f, 8g 8h , 8b,  
 (43) (11) (21) 8e 8h ,  
3  
 3 9a 14c 9a 9c  
 9b 3 10a 10c  
 10b 3 11a 11c  
 11b 3 12a 12c  
 12b 3 13a 13c  
 13b 3 14a 14c  
 14b 3 9a 14c ,  
 1 가 8h 가  
 가 , 1a 8h 가 1a 8h 가  
 'a' 'f'가 가 , 9a 14c  
 1 가 9b, 10b, 11b, 12b, 13b 14b  
 2 'e'가 가  
 (base body) 가 ' ' 가  
 9a 14c (10a 10f) (11) , 가 (  
 11) (10a) 9a 9c (22a) (11) (22a)  
 9a 9b (30a) (30a) 가 (30a)  
 (22a) 가 (22a) (30a)  
 (30a) (22a) (30ae) 가 , (22a) (22a) (22ae)

(30a) , 9a (21a) , 9a , (21a)

1a 1h , (21a) , 'ln<sub>2-x</sub> Sn<sub>x</sub> O<sub>3-y</sub> (0.05 y 0.2)'가 , ,

(30a) , ln<sub>2-x</sub> Sn<sub>x</sub> O<sub>3-y</sub> (0.05 y 0.2) (22a) (30a)

(22a) , (30a) , (21a) , (22)

가 , (30a) , (21a) , ,

(30a) , (21a) , (43a) 'ln<sub>2-x</sub> Sn<sub>x</sub> O<sub>3-y</sub> (0.05 y 0.2)' , (22a) (30a)

(21a) 가 , (22a) (30a)

가 , 9c , (43) (21a) , 1c, 1d, 1g 1h , (30a)

(21a) 가 , (43a) , (22a) (30a)

가 , (10b) 10a 10c , 10a , (30b)

(22a) 9a (22a) 가 , (11) (22a) (30b)

9b , 가 , (30b) , 10a , (21b) , (30b)

9 (22a) , 가 , (21b) (30b) (21b) 가 , ,

(22a) (22ae) 가 , (21a) (21be) , ,

(21b) 'ln<sub>2-x</sub> Sn<sub>x</sub> O<sub>3-y</sub> (0.05 y 0.2)'가 , ,

(30b) ln<sub>2-x</sub> Sn<sub>x</sub> O<sub>3-y</sub> (0.05 y 0.2) (22a) (30b) (22a) (21b)

가 (22a) (21b) (30b) , (22a) (22a) (21b)

가 ln<sub>2-x</sub> Sn<sub>x</sub> O<sub>3-y</sub> (0.05 y 0.2) (30b) (30b) (22a)

(10b) , (30b) (21b) (10b) , (22a)

가 , 9a 9c (21b) (10b) (30b)

가 , (21b) , (30b) 가 , (30b)

가 , (10b) , / , 가

(22a) (22a) (30b) (30b)

(22a) 가 , 가 , (21b) (30b)

(30b) , 가 , 가 (30b)

10c , 'ln<sub>2-x</sub> Sn<sub>x</sub> O<sub>3-y</sub> (0.05 y 0.2)' (21b) (30b) 가 , 가 (21b)

(43b) (43b) (30b) (30b) 가 , 가

가 , (21b) (22a) (30b) / , (21b)

(43b) , 1a 4h , ( ) , (21b)

(22a) (10c) 11a 11c , 11a , (30c)

(22a) 9a 9c 10a 10c , (30c)

) (30ce) (22a) 9a 9c 10a 10c , (30c)

(30ce) (44c) (44ce) , 11b (44c) , (22a) (30c)

(11) (21b) (30c) 10a (21b) 'ln<sub>2</sub>  
 $\text{In}_{2-x}\text{Sn}_x\text{O}_{3-y}$  (0.05 y 0.2)'가 , ,  
(22a) (30c) (30c)  $\text{In}_{2-x}\text{Sn}_x\text{O}_{3-y}$  (0.05 y 0.2)  $\text{In}_{2-x}\text{Sn}_x\text{O}_{3-y}$  (0.05 y 0.2)가  
(10c) (22a) (30c) (44c) (44c) 가  
(30c) (30c) 가 (22a) (22a) ,  
(30c) 가 (30c) (21b) ( )  
11c (43c)  $\text{In}_{2-x}\text{Sn}_x\text{O}_{3-y}$  (0.05 y 0.2) (21b) (21b)  
(43c) (30c) 가 가  
(21b) (22a) (30c) / ( ) (21b)  
(43b) 1a 4h  
(10d) 12a 12c (10d) 11a 11c (1)  
(10c) 12a, 12b 12c 11a, 11b 11c (44d) (44de)  
0d) 12b (10c) (44d) (30c) (22a) (21d) 가  
(10c) (44d) (11a) 11c (30c)  
(10d) 11a 11c  
(10e) 13a 13c (10e) 10a 10c  
(10b) 13a, 13b 13c 10a, 10b 10c (10e) (10e)  
(30b) (44e) (10b) (22a) (22a)  
10a 10c (11) (22a) (30b) (22a) (22a)  
(10e) (21b) (21b) (21be) (30b) (44e)  
(44ee) (30b) (21b) 13a 13c (44e)  
(21b)  $\text{In}_{2-x}\text{Sn}_x\text{O}_{3-y}$  (0.05 y 0.2)가 ,  
(22a)  $\text{In}_{2-x}\text{Sn}_x\text{O}_{3-y}$  (0.05 y 0.2) (44e)  
(30b)  $\text{In}_{2-x}\text{Sn}_x\text{O}_{3-y}$  (0.05 y 0.2) (30b)  
(22a) (22a) (30b) (30b)  
(22a) 가 (21b) (30b) (30b)  
(21b) (21b) (30b)  
13c (43e) 'ln<sub>2</sub> $\text{In}_{2-x}\text{Sn}_x\text{O}_{3-y}$  (0.05 y 0.2)' (2)  
1b) (43c) (21b)  
가 가 (22a) (30b) / (43c) (21b) ( )  
(10f) 14a 14c (10f) 13a 13c  
(10d) 14a, 14b 14c 13a, 13b 13c 14a 14c  
(21b) (44f) (44fe)  
(44f) (21b) (10d) (44f)



17a (10i) (21h) (30i) (30i)

(10i) (21h) (30i) (10i) (21h)

$n_x O_{3-y} (0.05 y 0.2)$ 가 (21h) 가  $\ln_{2-x} S$

10g 10i) 5a 8h 15a 17b (

$\frac{5}{9a}$  14c 3 5 18 18b 5 18

a 25c 18a 18c 5 18b 5

5 19a 19c 5 19b

20b 5 20a 20c 5 21a 21c 5

21b 5 22a 22c 5

22b 5 23a 23c 5

23b 5 24a

24c 5 24b 5

25a 25c 25b 5

18a 25c 가 9c 14c

(10j) 5 가

18a 25c 5a 가 8h 가

5c 1b, 22b, 23b, 24b 2 25b 'e'가 가 18a 25c 가 5a 8h 가 18a 2 '가' 's'가 가 18b, 19b, 20b, 2 가

가 10j 10s) (10j) 10s) (11) (1

가 (10j) 18a 18c (21j) 18a (11)

(21j) (30j) (21j) (30j) 가 (30j) 가 (30j)

(23j) 가  $\ln_{2-x} Sn_x O_{3-y} (0.05 y 0.2)$ 가 (30j) (21j)

(30j) (23j)  $\ln_{2-x} Sn_x O_{3-y} (0.05 y 0.2)$ 가  $\ln_{2-x} Sn_x O_{3-y} (0.05 y 0.2)$ 가

(30b) (21j) (30j)

가 (23j) (30j) 가 (30j)

18c (43j) ' $\ln_{2-x} Sn_x O_{3-y} (0.05 y 0.2)$ ' (2

1j) 가 (43j) (21j) 가

가 (23j) (30j) / 가 3 (10j)

5c, 5d, 5g 5h (10k) 19a 19c 19a 19c

(10k) 18a 18c 19a, 19b 19c 18a, 18b 18c

19a 19c (10k) , (30k) , (21k)  
 (30k) (30k) (21k) 18a 18c , ,  
 k) (23j) 가 In<sub>2-x</sub>Sn<sub>x</sub>O<sub>3-y</sub> (0.05 y 0.2)가 (30) (23j)  
 (21k) , , In<sub>2-x</sub>Sn<sub>x</sub>O<sub>3-y</sub> (0.05 y 0.2)가  
 (23k) (30k) 'In<sub>2-x</sub>Sn<sub>x</sub>O<sub>3-y</sub> (0.05 y 0.2)'  
 (30k) 가 , (30k) 가  
 , 18a 18c , (30k) 가  
 가 (30k) (30k) (30k) 가  
 , (21k) (30k) (30k) 가 (2  
 1k) 가 (23j) (30k) (30k) 가  
 , 가 (23j) (30k) ,  
 19c , 'In<sub>2-x</sub>Sn<sub>x</sub>O<sub>3-y</sub> (0.05 y 0.2)'  
 (43j) (43j) (21k) (21k)  
 가, (23j) (30k) /  
 , (10k) ( )  
 , (10m) 19a 19c 20a 20c , 20a 20c 19a, 19b, 19c  
 20a 20c (10m) , (21k) (30k)  
 (23m) 19a 19c , (23m)  
 19a 19c , (21k) ,  
 , (23m) (30k) - (oxygen-deficient  
 characteristic) 'In<sub>2-x</sub>Sn<sub>x</sub>O<sub>3-y</sub> (0.05 y 0.2)'  
 2-x Sn<sub>x</sub>O<sub>3-y</sub> (0.05 y 0.2)' (30k) , 'In  
 가 , 18a 18c , (30k) (30k) (23m)  
 , (30k) (30k) (23m) (23m)  
 (30k) (23m) 가 ,  
 , (30k) (21k) (30k) (21k)  
 , 가, (30k) (23m) 가  
 , (30k) (23m) ,  
 20c , (21k) (11) (43j) ,  
 (43j) (21k)  
 , 가, (23m) (30k) /  
 , (10m) ( )  
 , (10n) 21a 21c , 21a, 21b, 2  
 1c 20a, 20b, 20c (10n) 20a 20c , 21a, 21b, 2  
 20a 20c (10n) , (30n) (11) (21k)  
 ) (23n) (21k) (23k)  
 , 20a 20c ,  
 (30n) (23k)  
 19a 19c , (21k) ,

(30n) (23n)  $\text{In}_{2-x}\text{Sn}_x\text{O}_{3-y}$  (0.05 y 0.2) (30n)  
 $\text{In}_{2-x}\text{Sn}_x\text{O}_{3-y}$  (0.05 y 0.2)' (30n)  
 18a 18c (30n) (23n) 가 (21k)  
 (30k) (23n) (30n) 가 (21k)  
 (30n) 가 (43j)  $\text{In}_{2-x}\text{Sn}_x\text{O}_{3-y}$  (0.05 y 0.2)' (21k)  
 21c (11) 가 (23n) (30n) / (21k)  
 (21k) (11) 가 (23n) (30n) / (21k)  
 ( ) (10n) 22a 22c 22a, 22b, 22c  
 22a 22c (10p) 21a 21c (21k)  
 c 22a 21a, 21b, 21c (30p) (21k)  
 22a 22c (30p) (21k)  
 (44p) 21a 21c (30p)  
 19a 19c (21k) (21k)  
 ) (23n)  $\text{In}_{2-x}\text{Sn}_x\text{O}_{3-y}$  (0.05 y 0.2)' (30p)  
 (30p) (23n)  $\text{In}_{2-x}\text{Sn}_x\text{O}_{3-y}$  (0.05 y 0.2)' (30p)  
 (10p) (21k) (30p) (44p) (44p)  
 buried), 가 가 가 가 (44p)  
 (30p) (21k) (21k) (30p)  
 (21k) (30p) (23n)  
 (30p) (23n)  
 22c (43j)  $\text{In}_{2-x}\text{Sn}_x\text{O}_{3-y}$  (0.05 y 0.2)' (21k)  
 (21k) (11) 가 (23n) (30p) / (21k)  
 ( ) (10p) /  
 (10q) 23a 23c 23a, 23b, 23c  
 c 23a 23c (10q) 22a 22c (23q)  
 23a 23c (10q) (44q) (end portion; 44qe)가 (30p)  
 22a 22c (44q)  
 (30p) (leakage current)가 (23q)  
 (21k) (44q)  
 (30p) (10q)  
 22a 22c (10r) 24a 24c 24a, 24b, 24c  
 c 24a 24c (10r) 23a 23c (24q)  
 24a 23a, 23b, 23c (23r) (30r)  
 (44r) 24c (10r) 23a 23c (30r) 21a 21c  
 (10n) 23a 23c (moisture-resistance) 가 가 (44q)  
 가, 22a 22c (10p) 가 (10r) (stacked layer)  
 가 (10s) 25a 25c  
 c 25a 25c (10s) 24a 24c 25a, 25b, 25c  
 24a, 24b, 24c

25a 25c (10s) (44s) (44se)가 (23n) (23ne)  
 24a 24c , (44se) (23n)  
 ) , (44s) (30n) , (44se) (44se) (44se) (44se)  
 , (10s)  
 2 5a 8h 24a 24c (10r) 18a 25b (10j) 10s  
6  
 6a (10u) 26a 28b  
 6 27a 26b 6 28b  
 , 28b 6  
 가, 26a 28b , 5a 8h  
 8h 26a 28b 5a 8h  
 가 , 'u' 'w' 26a 28c 가  
 , 2 'e' 26b, 27b, 28b 1  
 가  
 18a 25c (10j) 10s) 가 (10u) 10  
 w) (11) 가 (11)  
 26a 26b (10u) (21u) (21u) (11)  
 , (30u) (30u) (21u) (30u) (23u)  
 (23)  
 27a 27b (10v) (10v) (21v) 26a 26b  
 (10v) (11) (30u)  
 30u) (23u)  
 27a (21) (10v) (10v) (21v)  
 (10v) (30u) (23u)  
 28a 28b (10w) (21v) (10w)  
 (21v) (30v) 27a 27b (10w)  
 (10w)  
 28a (21v) (10w) (10w) (30v)  
 (10w)  
 (21v), (10w) (10w) (23u)  
 (30v) (21u, 21v) 'In<sub>2-x</sub>Sn<sub>x</sub>O<sub>3-y</sub> (0.05 y 0.2)'  
 26a 28 5  
7  
 26 28  
 (10x) 가 29a 28b 29a  
 (10x) , 29b 7 (10x)  
 (10x) , 29a , (hermetri)  
 c) 가



35 (50) 10 (50)  
 50) 가 1 (51) 34 (53) 2 (52) (54)  
 36 (50) 10 (50) 35 1 (51) (53)  
 (55) 36  
 37 (50) 10 (50) 34 (72) (72D) (70)  
 (72D) (72) (72S) (72) (72S) (70)  
 (53) (70) (191)  
 54) 가 1 (72) (51) 2 (52) 가 (가)  
 (70), (72) (72G) 가 (53)  
 (70) 1 (51) 2 (52) 가 , ,  
 (72) (72G) 가 (70) 가 , ,  
 38 (50) 10 (50)  
 38 37 (50) 가  
 (54) 1 (51) (53) 2 (52)  
 39 10 (50) (50)  
 39 38 1 (51) (53)  
 (55)  
 11  
 40 42 (81 83)  
 가 40 11 (81 83)  
 1 (81), 2 (82) 3 (83)가 (11)  
 (82) 1 (81) , 3 (83) 2  
 41 11 (81a, 82a 83a)  
 41 1, 2 3 (81a, 82a 83a)  
 11a) 1 (81a) (81a, 82a 83a) (가)  
 , 2 (82a) , 3 (83a)  
 42 11 (81a, 82a 83a) 42  
 , (84) 1, 2 3 (82a 83a) (rib)(84)가  
 , (81a 82a) (82a 83a) 42  
 40 가 43 45  
 43 43 (81b, 82b 83b) (84) (33b) (84) 3  
 (81b, 82b 83b) (81b) , (22b) (11) (21b) (33b)  
 (22) , 1 (361) 1 (351) , 1 (351) (351)  
 (33) 1 (351) , (21b) (82b,83b) (81  
 b) 가 (81b) 5 , 1 , 2 (81b)  
 , 3  
 44 44  
 (22c) (11) 3 (가)  
 351-353) (22c) (361-363)  
 (351-353) (331-333) (361-363) (2  
 1c) (331-333) (22c), (351-353), (3  
 61-363) (331-333) , (351), (361),  
 , (81c) (11) (22c), (351), (361),  
 (331) (21c) 5 (82c, 83c) (81b)



(54)(30) (21) (30) (72) (72D) (53) (21)

15

1

[ 1 ]

| 발광 소자의 성분                       |  |
|---------------------------------|--|
| 기판                              | 유리, 수지, 퀴츠(quartz)   |
| 투명 전극층                          | ITO(Indium Tin Oxide)<br>주석과 인듐의 산화물의 혼합물  |
| 금속 전극층                          | MgAg, Al, LiAl   |
| 전자 전달층                          | 알루미늄퀴놀리논(Alq) 복합체, PBD, TAZ, BND, OXD(Oxadiazole derivative), OXD-7, PPV(Polyphenylene vinylene)   |
| 발광층                             | 알루미늄퀴놀리논 복합체에 적색 형광성 안료를 첨가함으로써 얻어진 물질, 한 종류의 형광성 물질을 함유하는 알루미늄퀴놀리논 복합체, 한 종류의 형광성 물질을 함유하는 베릴륨 벤조퀴놀리논 복합체, 한 종류의 형광성 물질을 함유하는 징크의 옥사졸 복합체, 한 종류의 형광성 물질을 함유하는 컨주게이트된 폴리머 유기 화합물의 프리커서, 프리커서는 예컨대 폴리비닐렌 페닐렌 또는 그의 유도체를 포함한다. 형광성 안료는 로다민 B, 디스틸 바이페닐, 테트라페닐 부타디엔, 퀴아크리돈 및 그들의 유도체를 포함한다. |
| 정공 주입층                          | TPD(Triphenyldiamine derivative), 코퍼(Copper) (II) 프타로시아닌의 포피린 화합물, $\alpha$ -NPD   |
| 에노드 버퍼층                         | CuPc, 폴리아닐린, 폴리싸오옌   |
| 보호층                             | Al의 산화물, Al의 질화물, Si의 산화물 또는 그들의 혼합물   |
| 흡습성 강화층                         | Ba의 산화물  |
| 스위칭 소자                          | 트랜지스터  |
| 전류 공급 소자                        | 트랜지스터  |
| 스위칭 배선, 전류 공급 배선, 공통 배선 및 접지 배선 | Al, Cu, Ta, Ru, WSi  |

de) , , , 가 , ITO(Indium Tin Oxide) , MgAg, Al, LiAl (Alq) , PBD, TAZ, BND, OXD(Oxadiazole derivative), OXD-7, PPV(Polyphenylene vinylene) 가 (conjugated) (precursor) B, , , , TPD(Triphenyldiamine derivative), (II) , -NP D , Al , Si , CuPc, , , , Al , Ba , , Al, Cu, Ta, Ru, WSi가

2

[ 2 ]

|  |                     |
|--|---------------------|
|  |                     |
|  | Al, Cu, Ta, Ru, Wsi |
|  | Al, Al, Si, Si,     |

2, Al, Cu, Ta, Ru, WSi가  
 , Si, Si 1, 2, Al, Si, Al

[ 3 ]

| 발광체의 봉입을 위한 성분 |   |
|----------------|---|
| 접착제            | UV(Ultraviolet) 경화 수지                           |
| 봉입 재료          | 금속, 유리 또는 수지                                    |
| 밀폐 가스          | N <sub>2</sub> , H <sub>2</sub> , 또는 Ar의 불활성 기체 |

UV 가 가 가 가  
 N<sub>2</sub>, H<sub>2</sub>, Ar 가 가  
 16

51a 51b 48  
 (511) (511) CVD( ) (511)  
 548) 51b CVD( 500 )  
 51c LP( ) CVD (500) (500)  
 CVD 52a (545) (500) (548) CVD  
 52c (545) 'SiO<sub>2</sub>' (500)  
 'WSi'  
 가

(524)  
 52c (500) (528) (529)가 (528) (529)  
 550 가 가 (528) (529)  
 D 53a 'SiO<sub>2</sub>' 1 (546)가 CV  
 (545) (524) (528) (529) 1 (546)  
 53b , Al (525) (526)  
 (524)  
 54a , 'SiO<sub>2</sub>' 2 (547)가  
 (526) 가 , (524)  
 54b (522) , 2  
 (547) (526) (524)  
 55a (530) , (522)  
 (530)  
 55b (521) CVD (530) (524)  
 (521)

가 가

(11), (41), (33), 8d (35), (36), (23), (21), (42)

18a 18c 가 (11)

27 (21v) (11)

29 가 가 35

30 가 가 35

50 30μm × 100μm 가 , AILi 40mm × 40mm -NPD가

가 , Alq가

(Al) 1 2 'In<sub>2-x</sub>Sn<sub>x</sub>O<sub>3-y</sub>'

Ar + O<sub>2</sub> 'In<sub>2-x</sub>Sn<sub>x</sub>'

'In<sub>2-x</sub>Sn<sub>x</sub>O<sub>3-y</sub>' 'y' O<sub>2</sub> Ar 'y'

(Rutherford back scattering: RBS) 'In<sub>2-xx</sub>Sn<sub>xx</sub>O<sub>3-y</sub>' 'xx' 'x' 'In<sub>2-xx</sub>Sn<sub>xx</sub>O<sub>3</sub>' (symbol value)

'xx' 'In<sub>2-x</sub>Sn<sub>x</sub>' 'x' 가 가

18c (Ba)

가

1 2

5V 가 가 1 ( )

2 ( ) 5V 가 , (photometer)

4 ( ) , 'In<sub>2-x</sub>

Sn<sub>x</sub>' 가 (A) 'In<sub>2-xx</sub>Sn<sub>xx</sub>O<sub>3-y</sub>' 가 'y' (B) 18A

4

|         | (A)    |        |        |       |        |       |       | (C)    |
|---------|--------|--------|--------|-------|--------|-------|-------|--------|
|         | y=0.01 | y=0.03 | y=0.06 | y=0.1 | y=0.15 | y=0.2 | y=0.3 | y=0.06 |
| x =0.05 | 49     | 48     | 340    | 280   | 320    | 220   | 21    | 570    |
| x =0.1  | 52     | 90     | 350    | 360   | 320    | 240   | 18    | 580    |
| x =0.2  | 47     | 45     | 360    | 330   | 340    | 250   | 17    | 460    |

4 'In<sub>2-x</sub>Sn<sub>x</sub>' 'x'가 '0.05, 0.1 0.2' 'y'가 '0.03' 100

'y' 0.06 0.2 , 220 'y'가 0.3 , 21

'y' 0.06 0.2 'y' 0.06 0.2

'In<sub>2-xx</sub>Sn<sub>xx</sub>O<sub>3-y</sub>' , 0.06 'y' 18c 가 'In<sub>2-xx</sub>Sn<sub>xx</sub>O<sub>3-y</sub>'

'y' (y=0.06) 'In<sub>2-xx</sub>Sn<sub>xx</sub>O<sub>3-y</sub>'

1.5 ,

가

(57)

1.

,  
,  
,

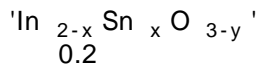

'y' 0.05

2.

1 (hygroscopic)

3.

1 (electroluminescence device)

4.

3 가 , 가

5.

3 , .

6.

3 , .

7.

1 3 , 2 3 , 3

, 1 , 2

, 3 ,

8.

7 , ,

9.

7 , ,

10.

, 3

11.

10 , ,

12.

11 ON/OFF , .

13.

12 ON/OFF

14.

'y'

15.

14

16.

14

17.

16

18.

16

19.

16

20.

1

16

2

3

3

1

3

2

21.

20

22.

20

23.

16

24.

23

25.

24

ON/OFF

26.

25

ON/OFF

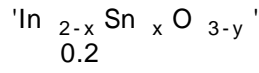

가

가

1

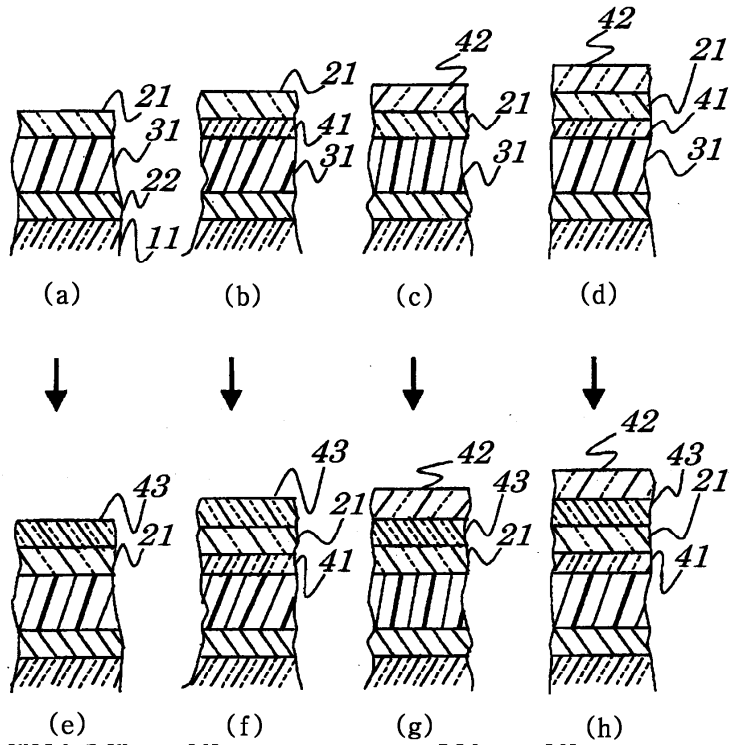

2

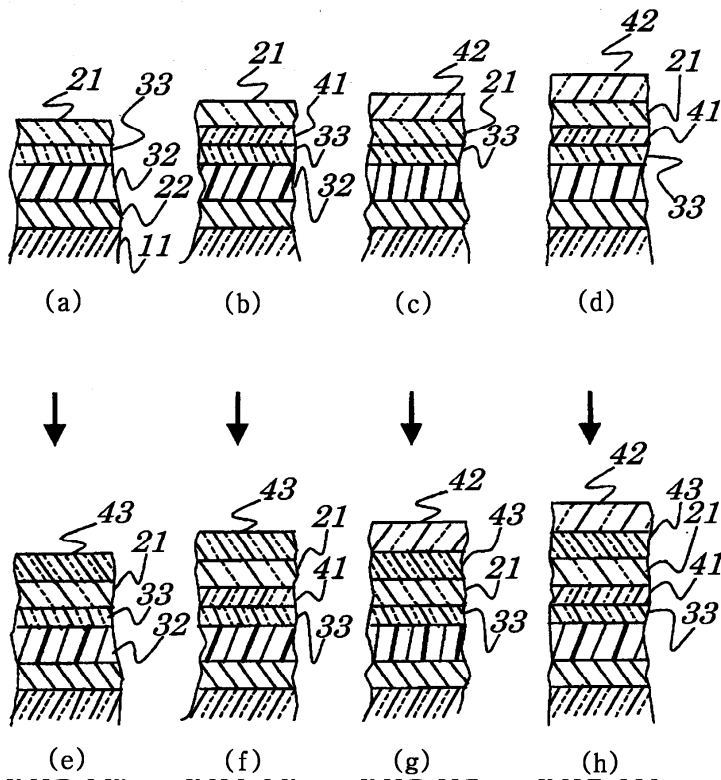

3

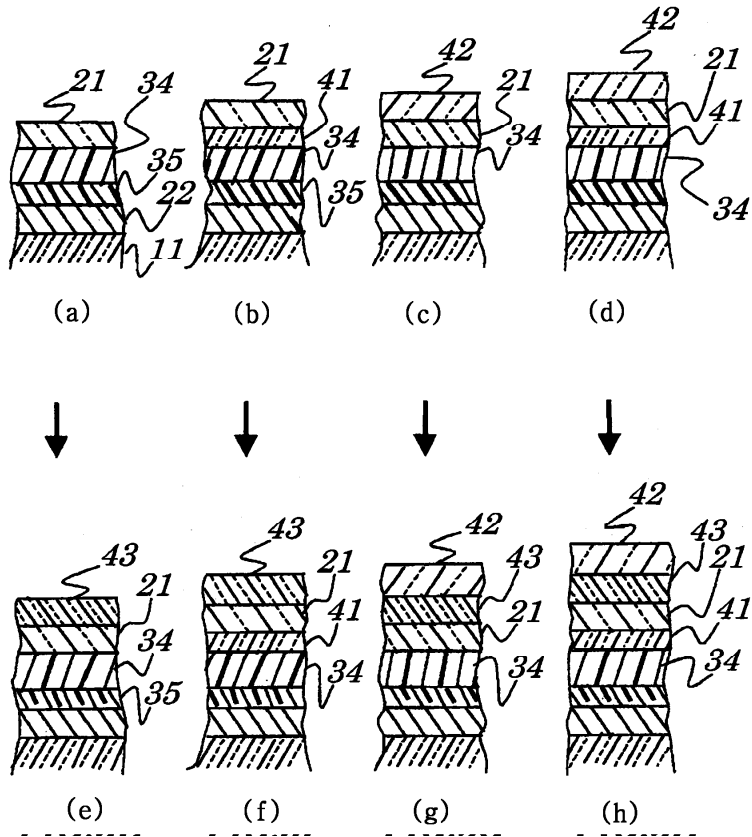

4

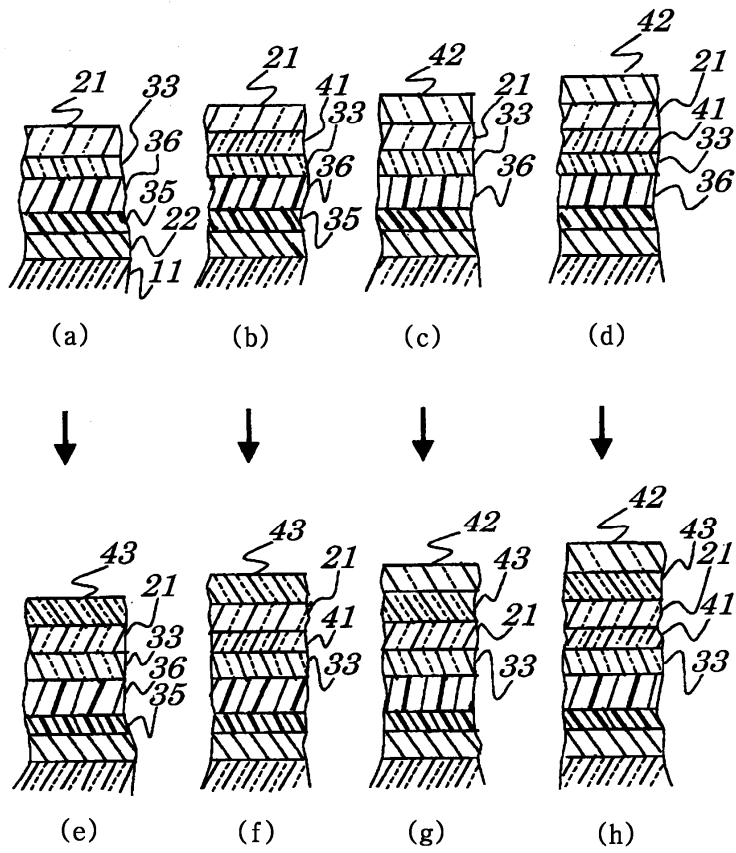

5

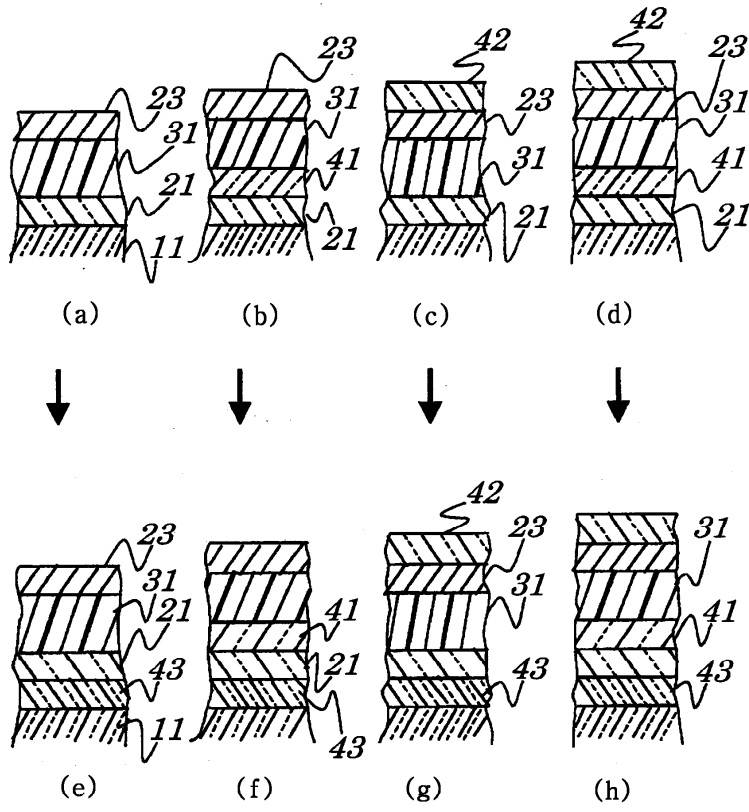

6

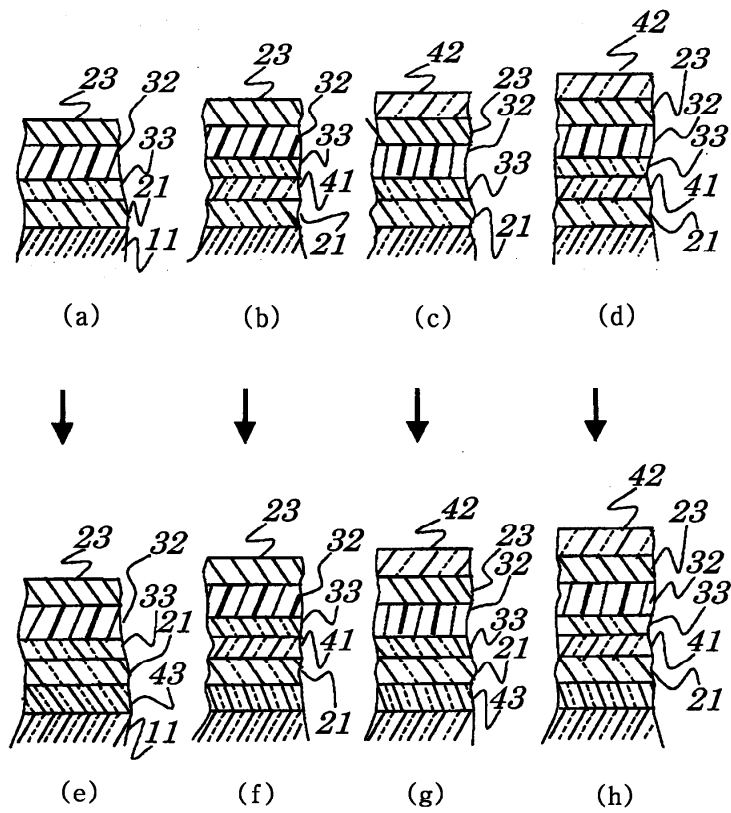

7

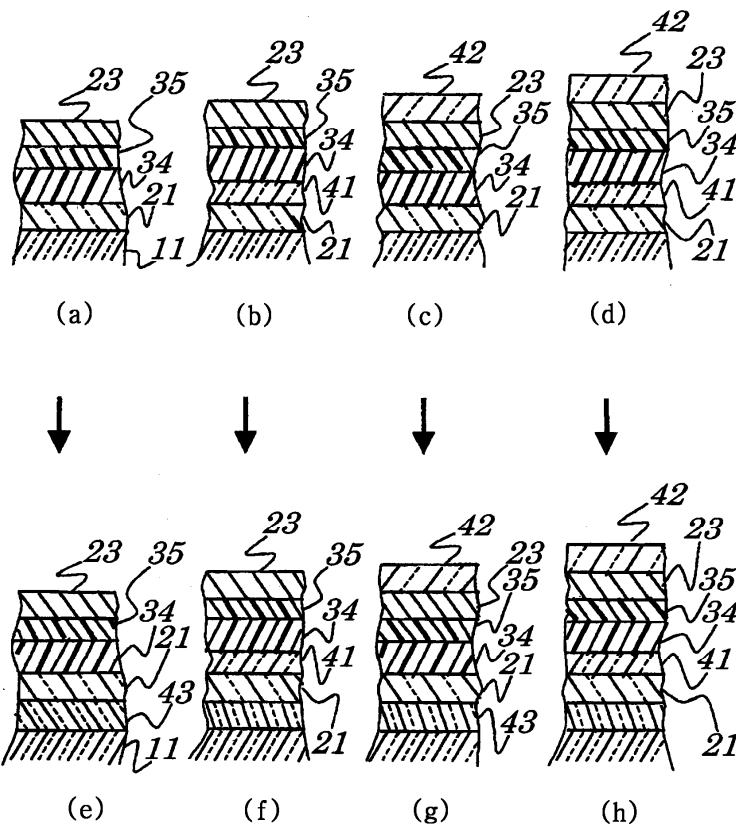

8

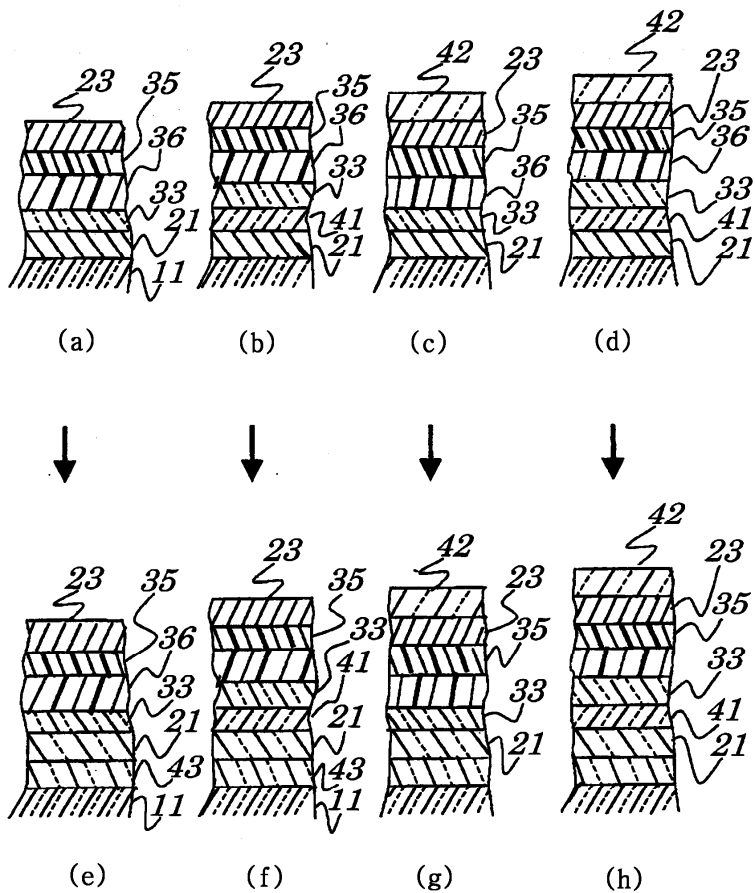

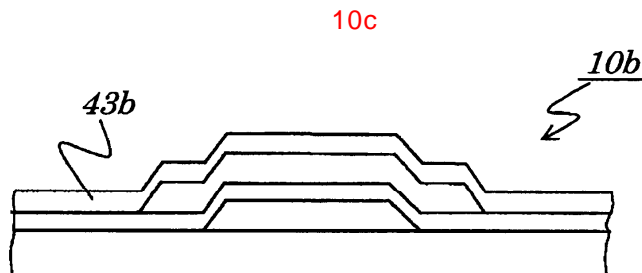
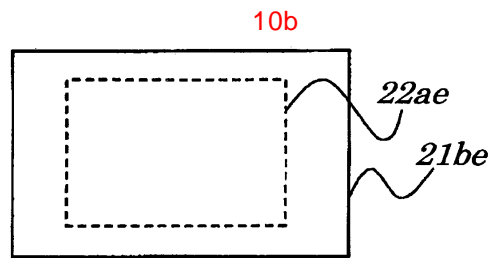
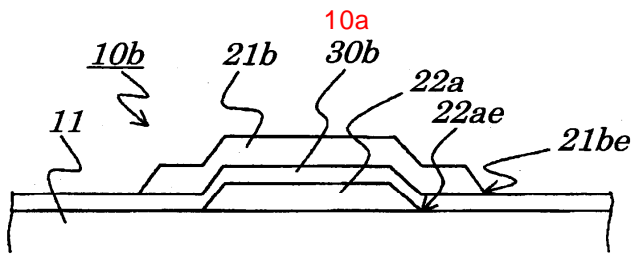
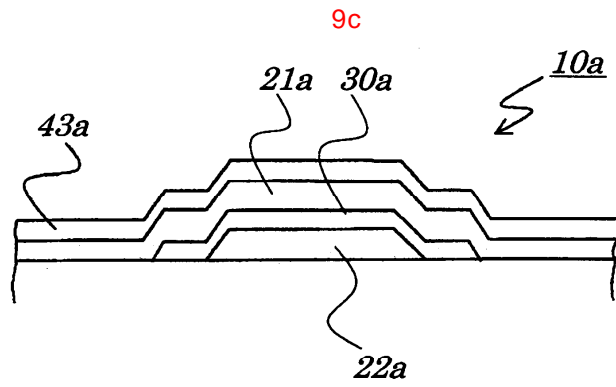
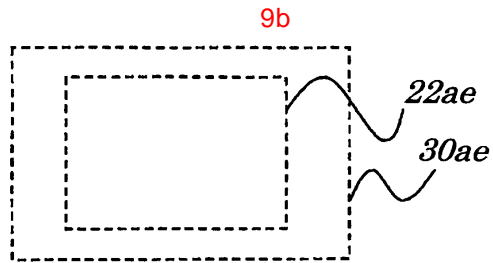
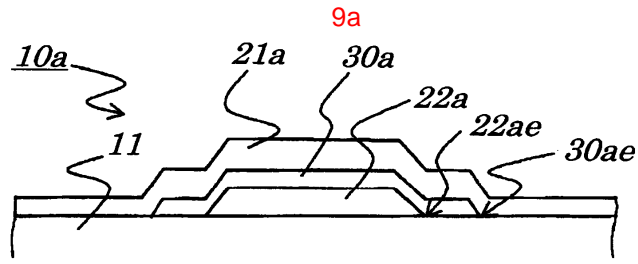

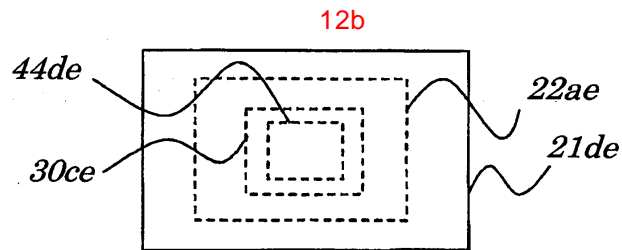
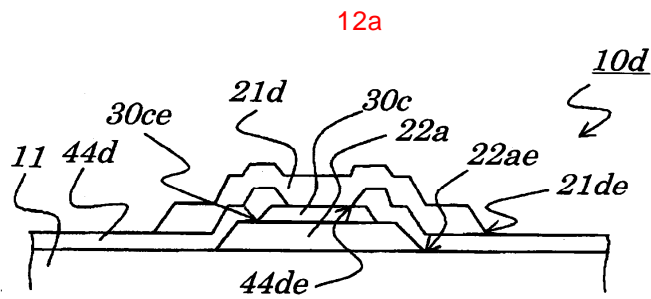
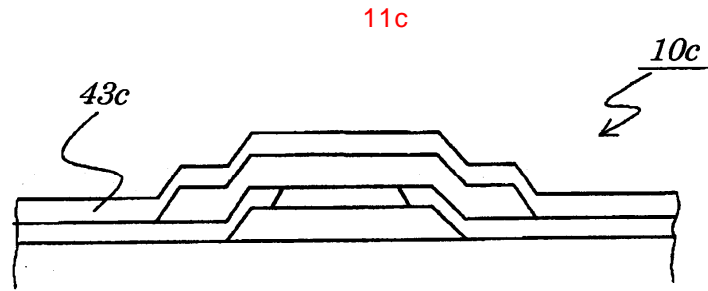
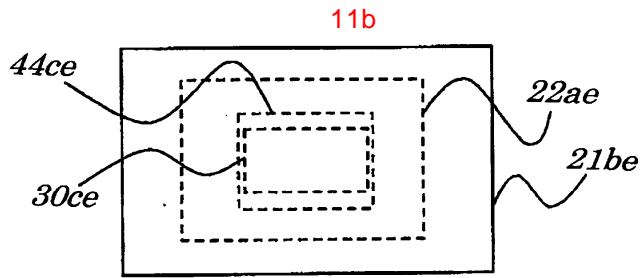
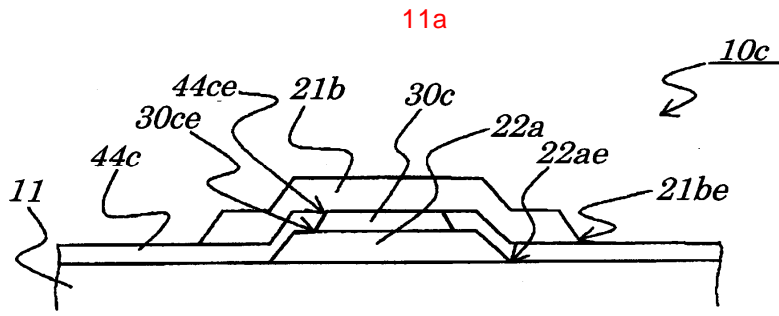

12c

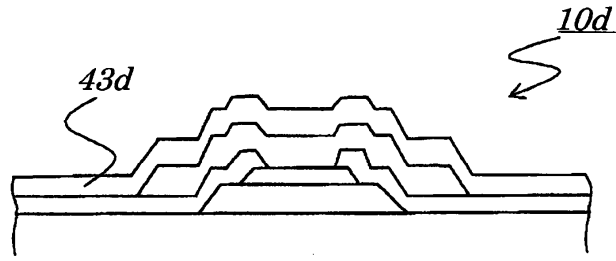

13a

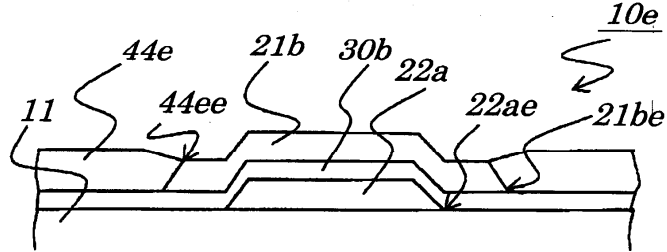

13b

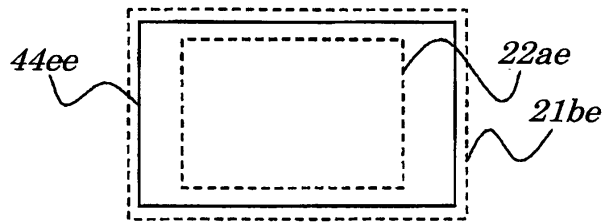

13c

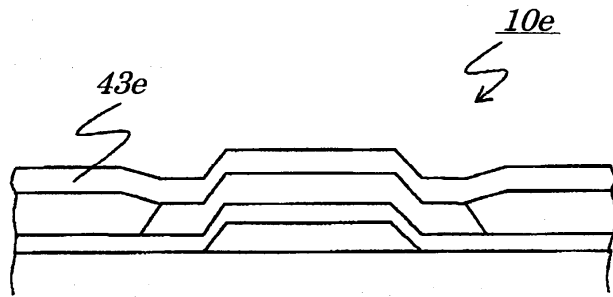

14a

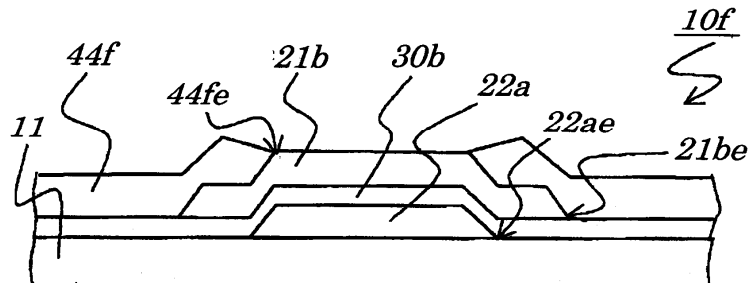

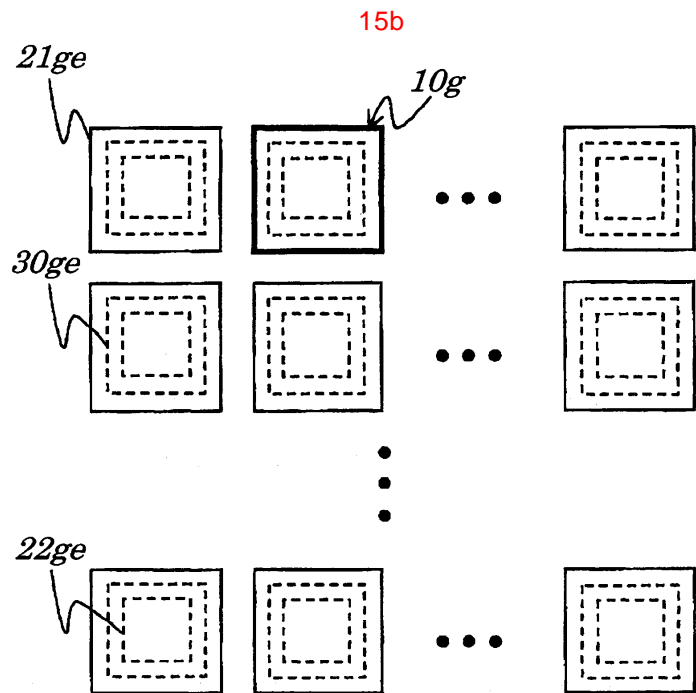
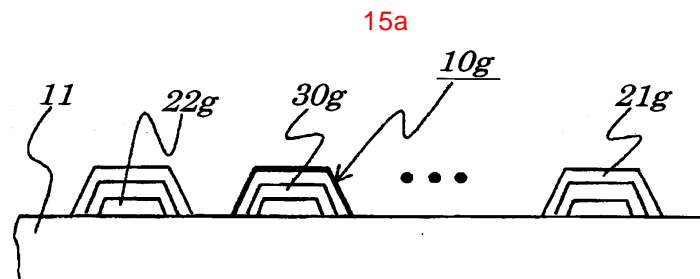
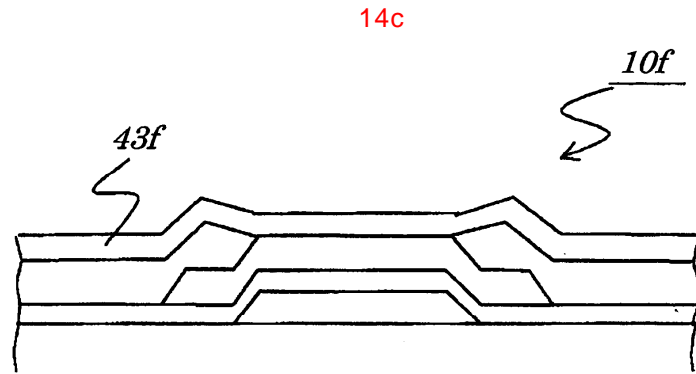
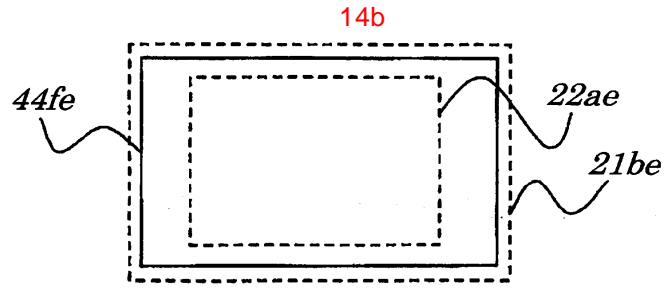

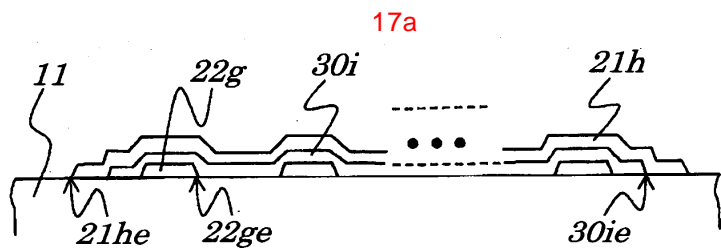
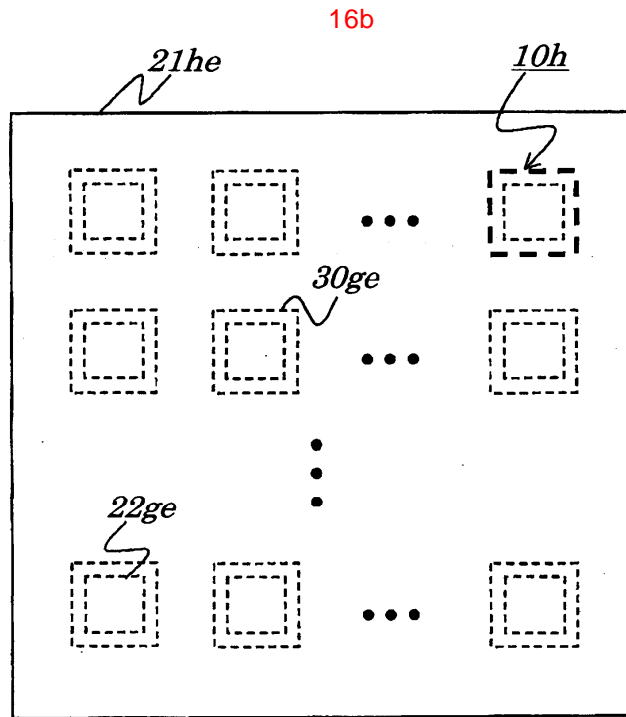
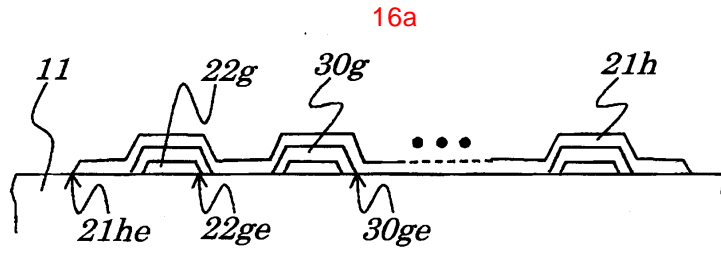

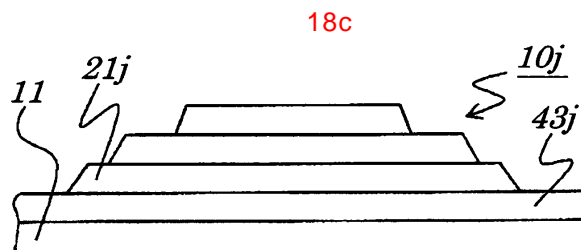
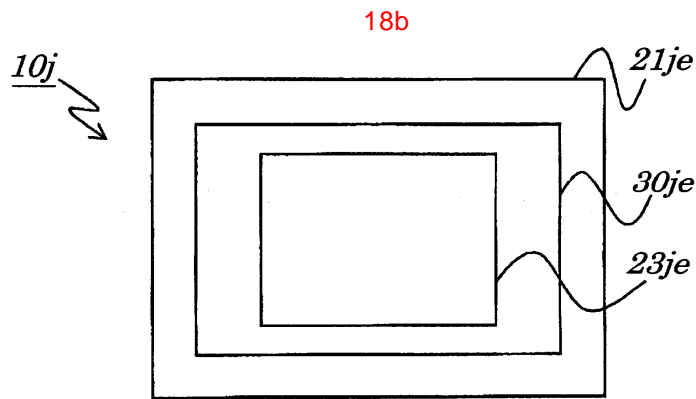
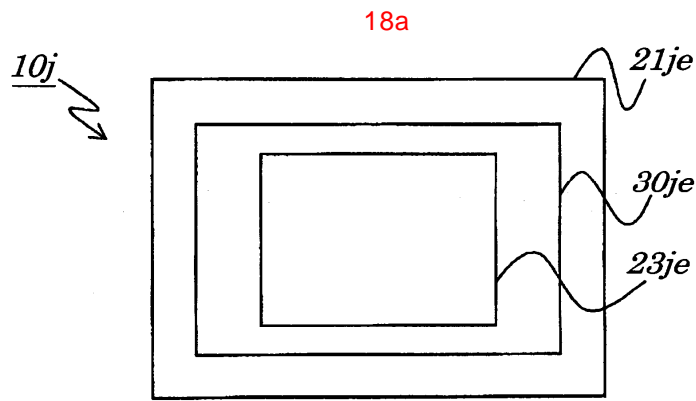
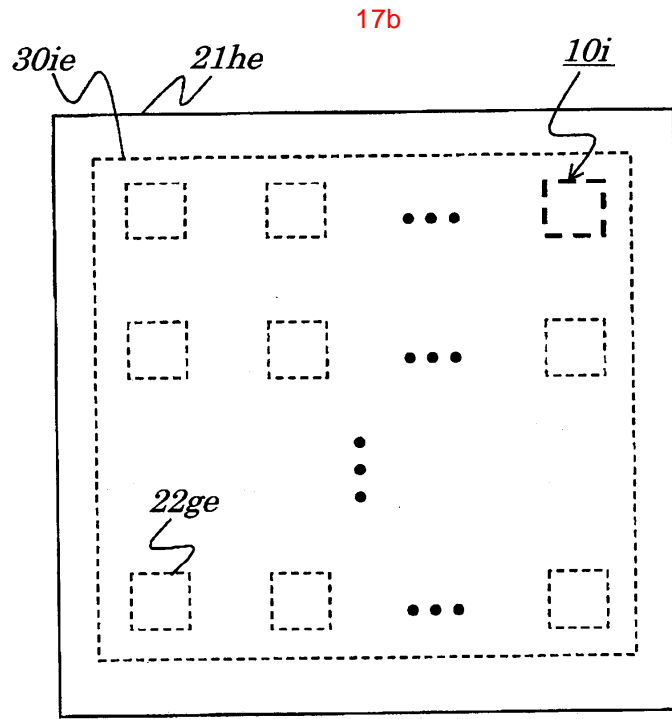

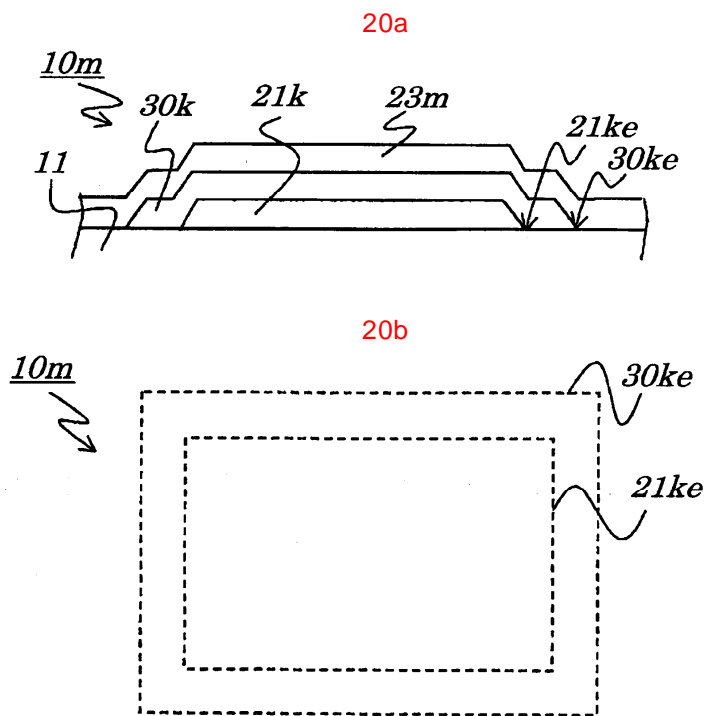
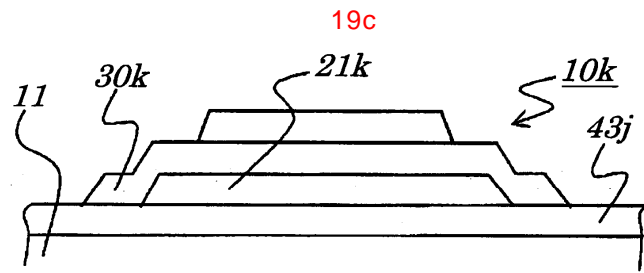
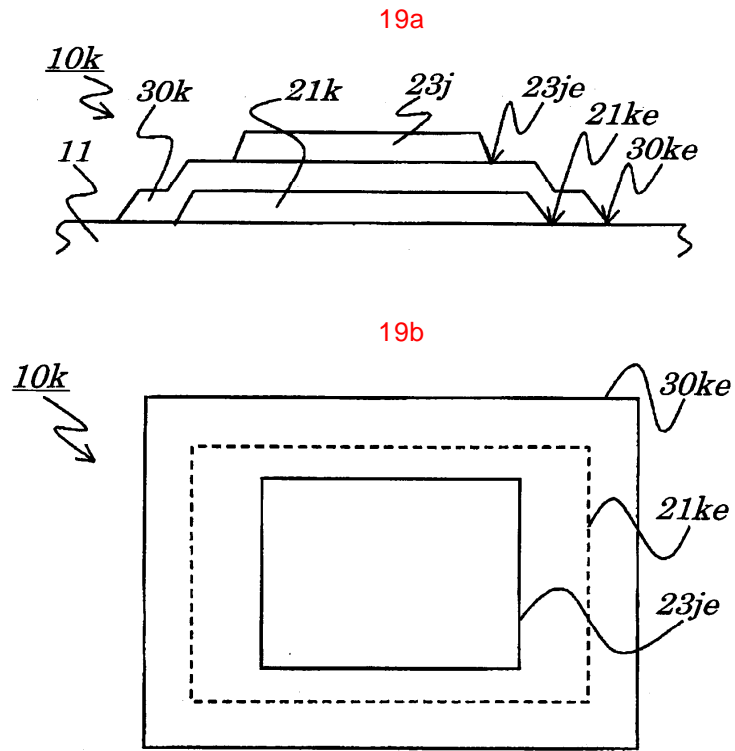

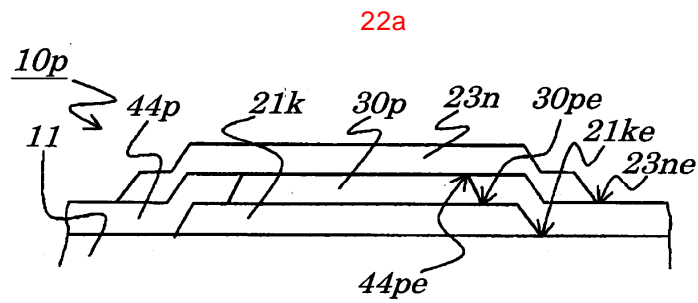
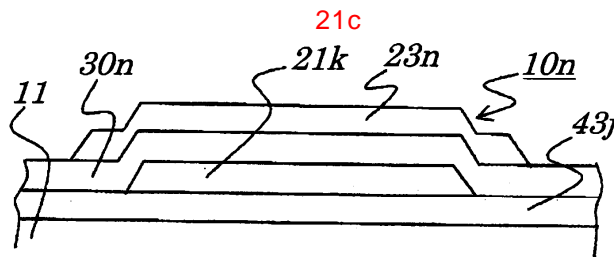
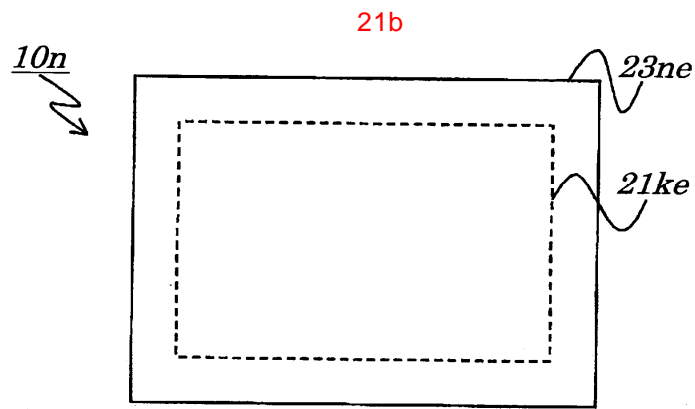
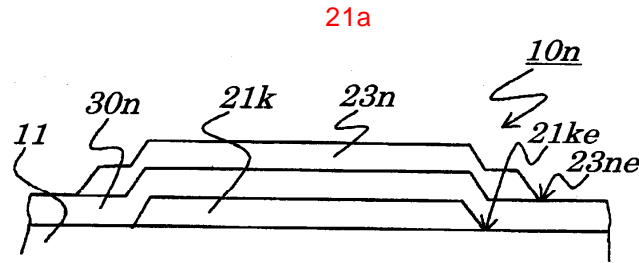
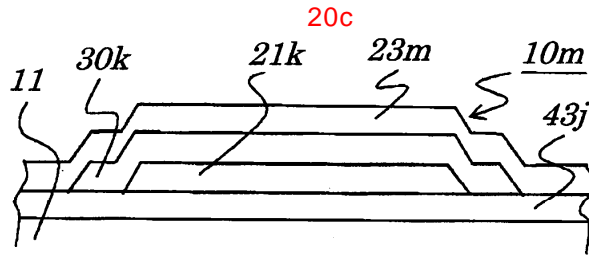

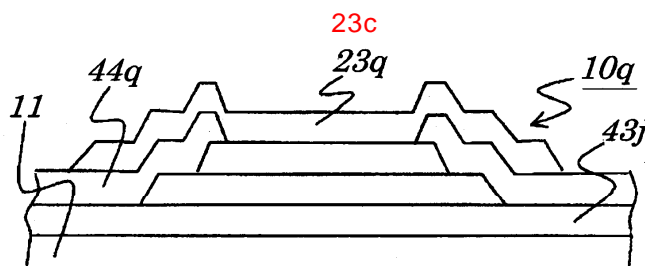
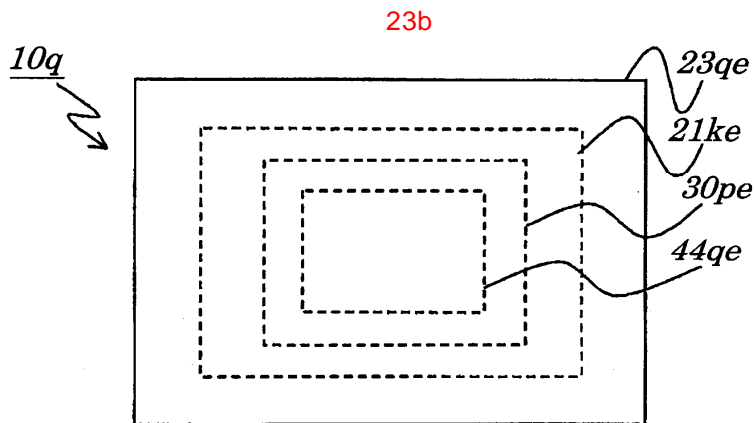
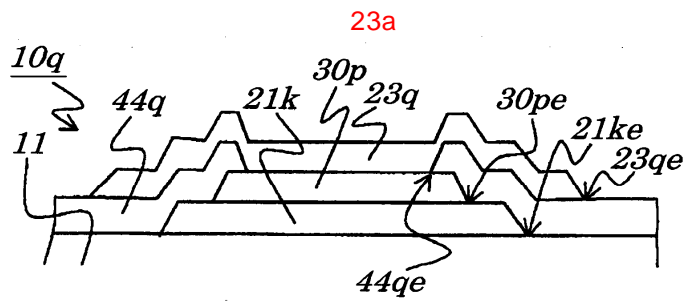
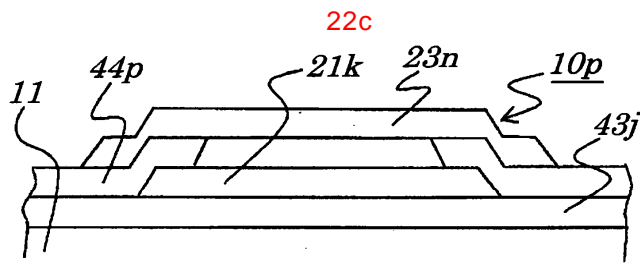
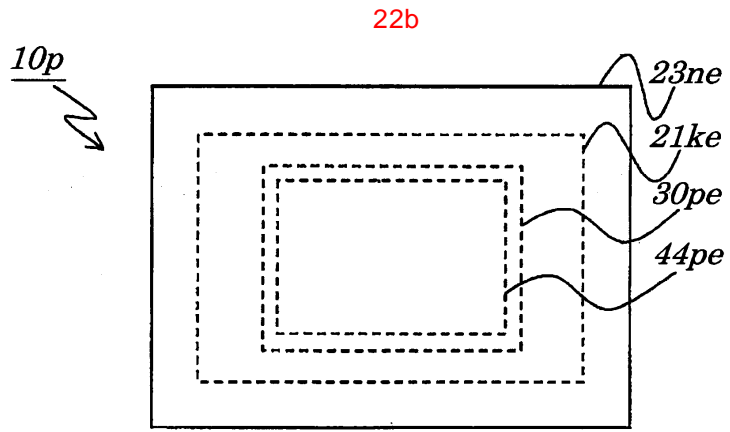

24a

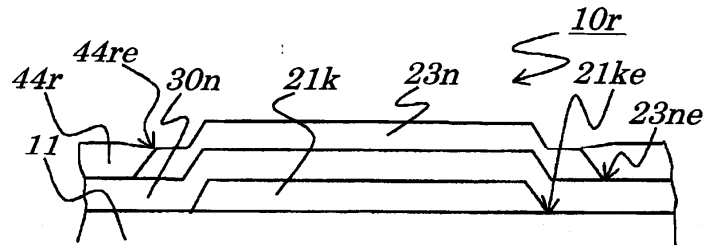

24b

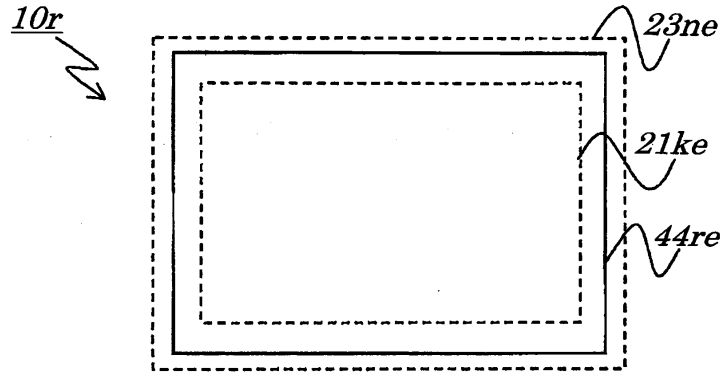

24c

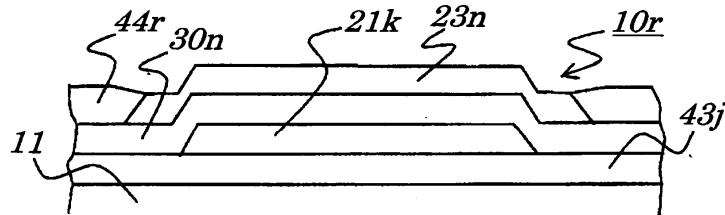

25a

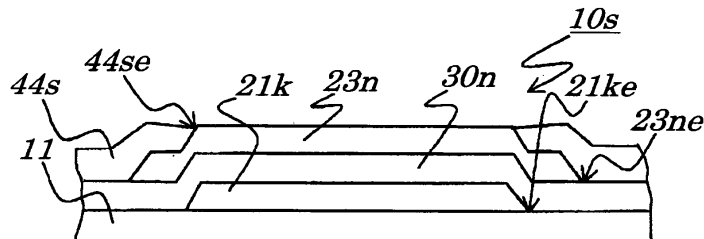

25b

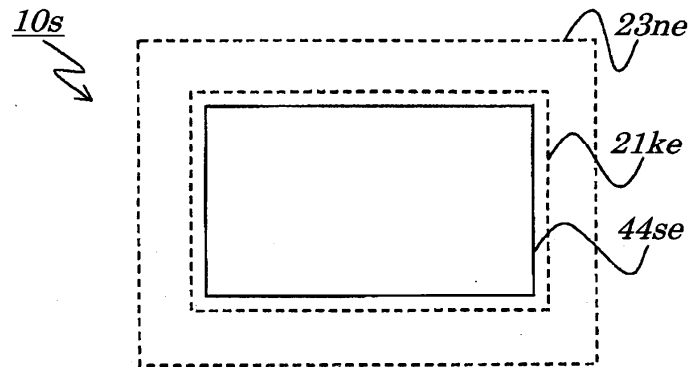

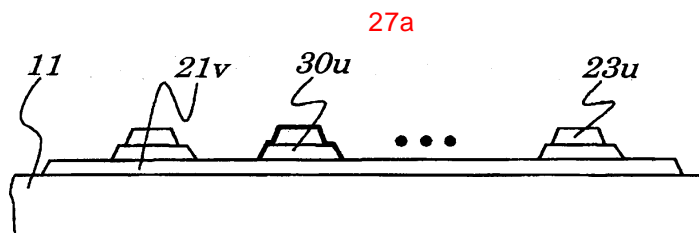
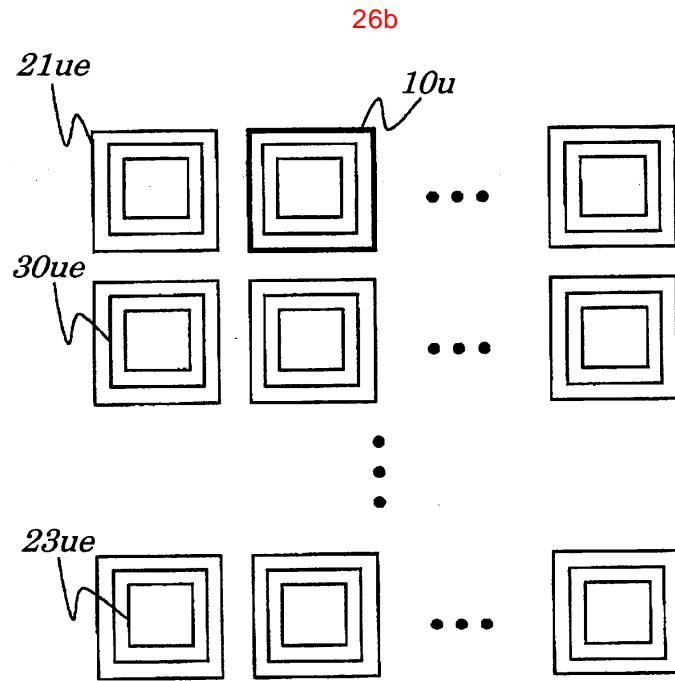
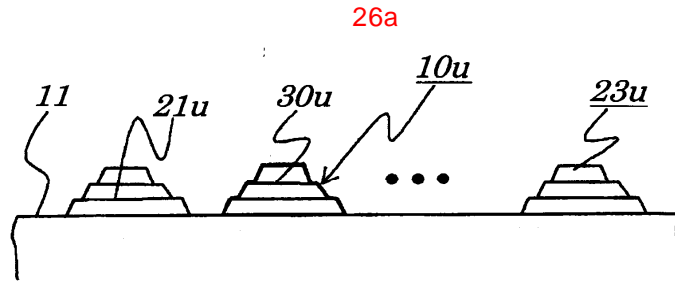
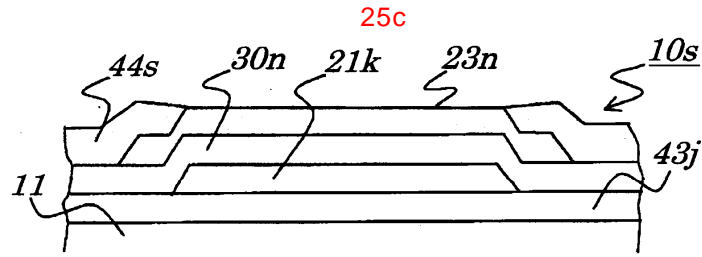

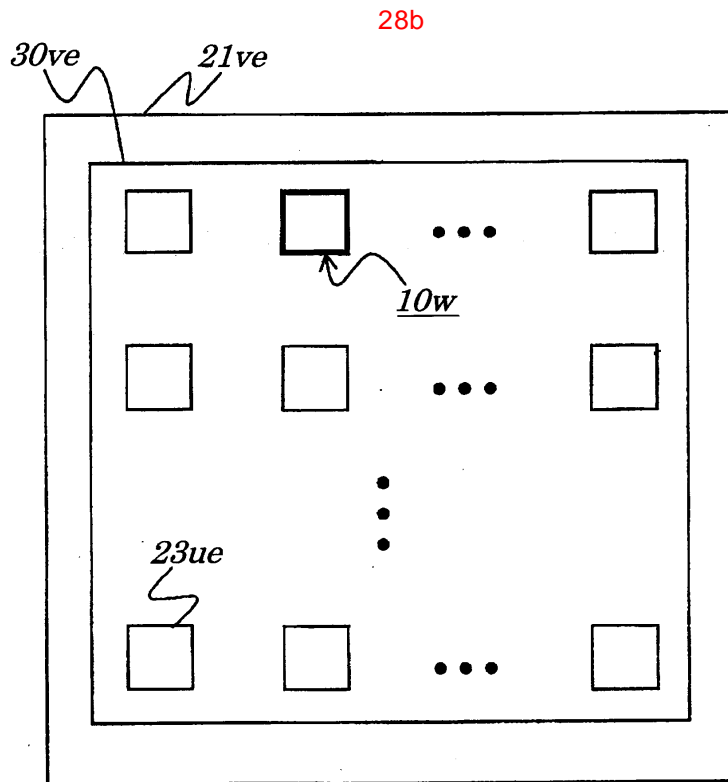
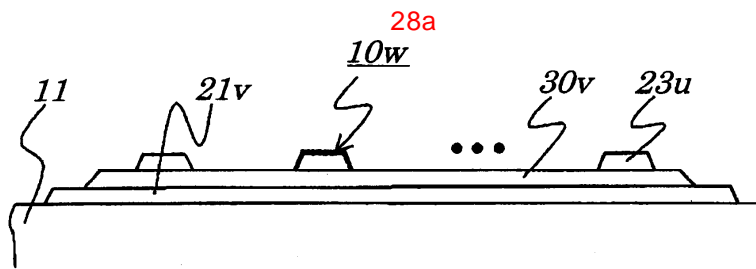
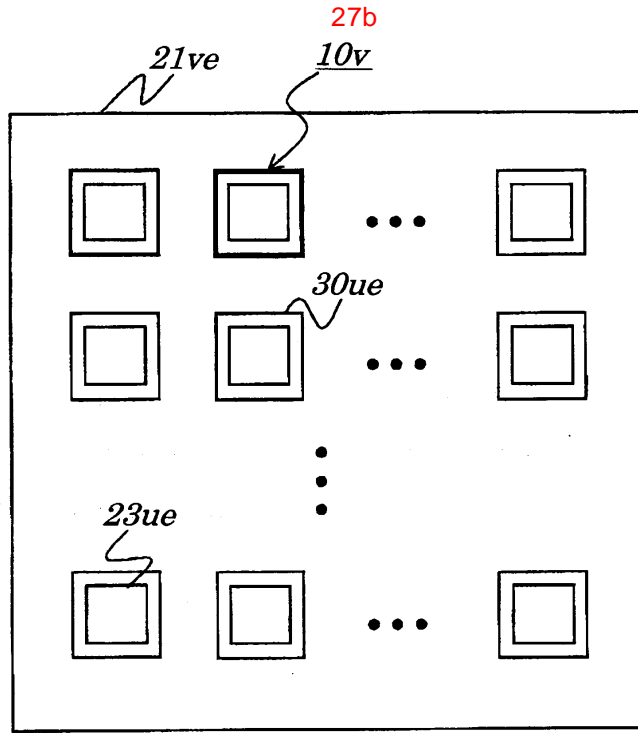

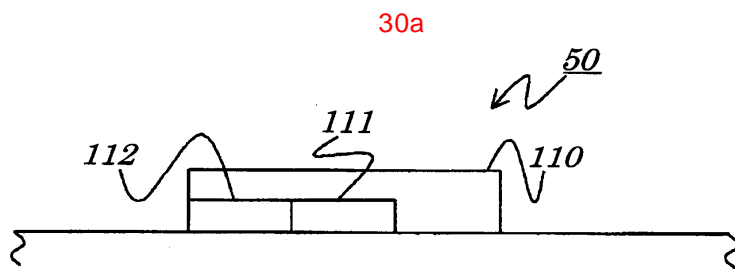
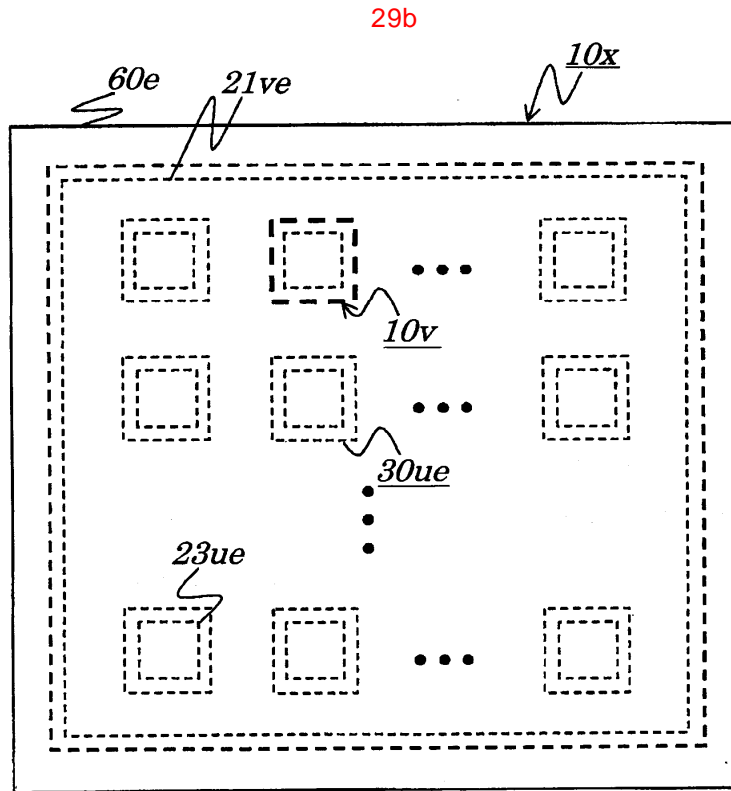
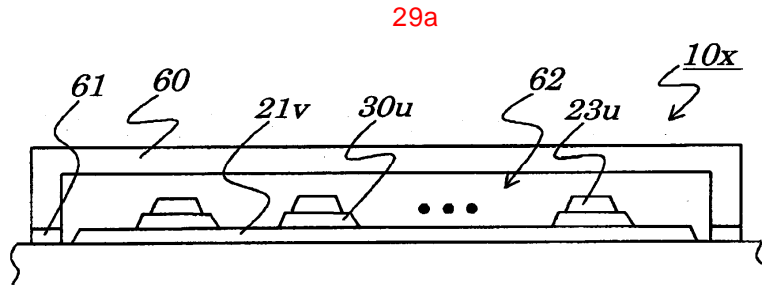

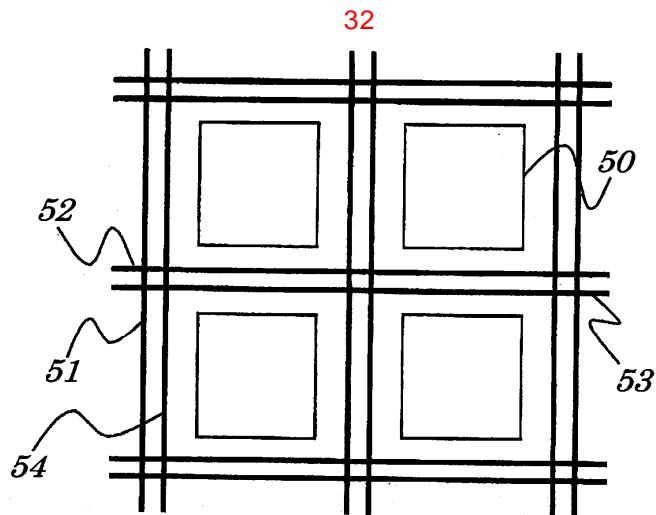
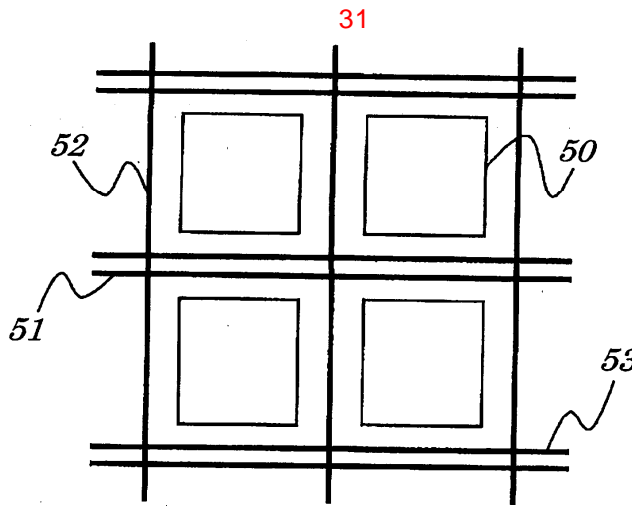
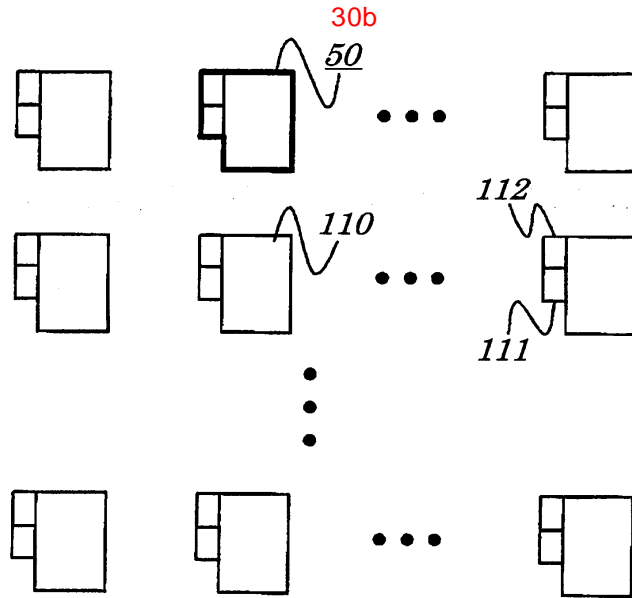

33

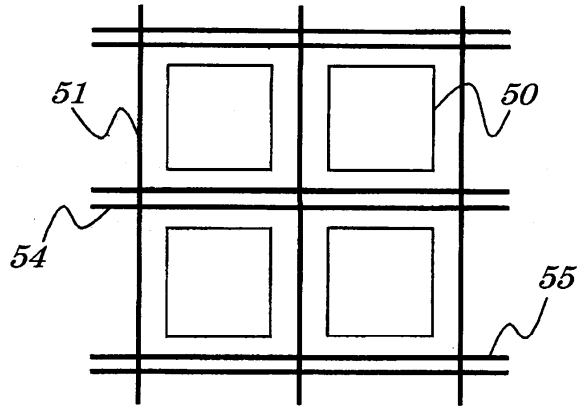

34

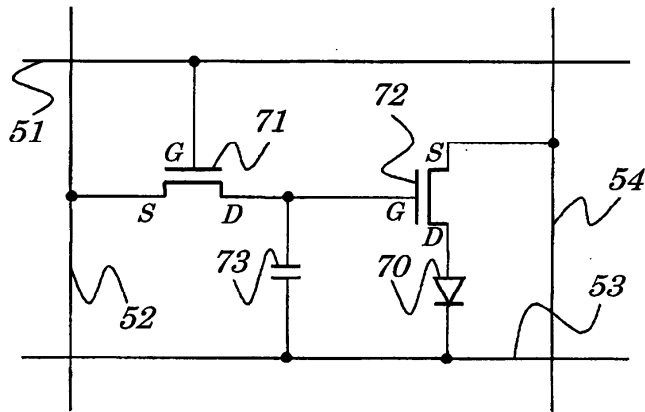

35

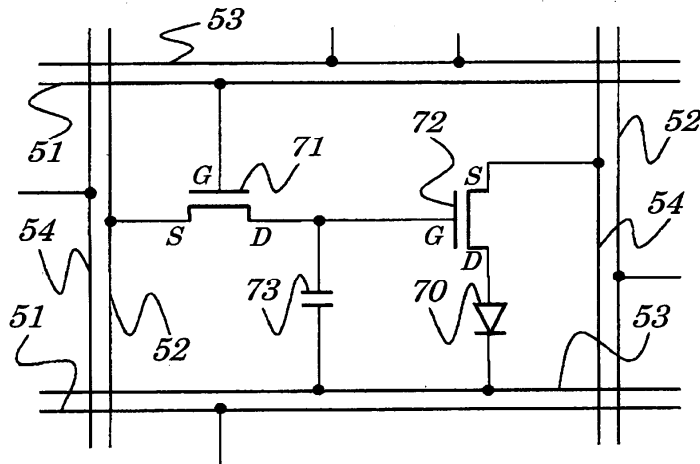

36

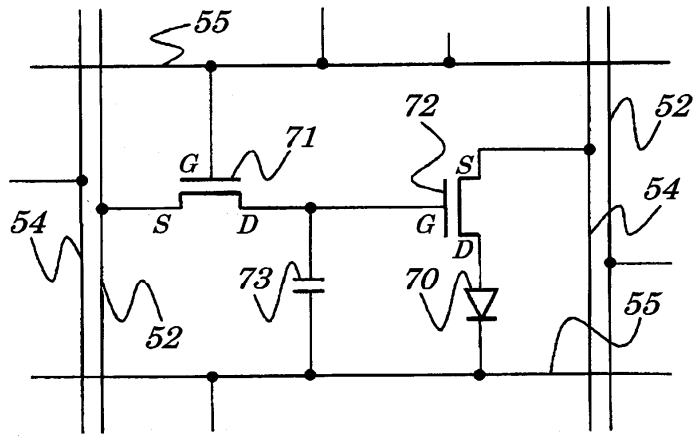

37

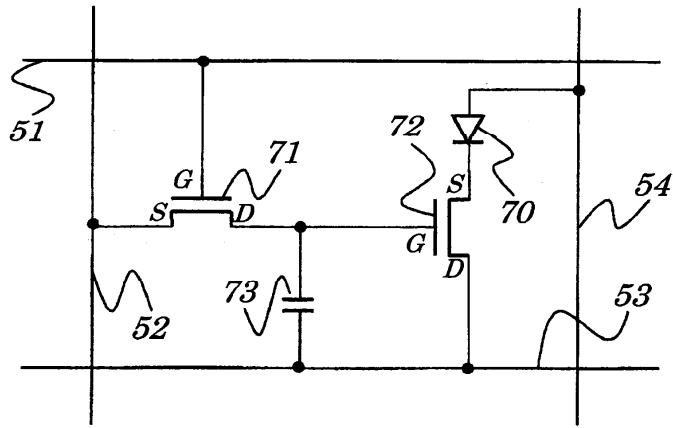

38

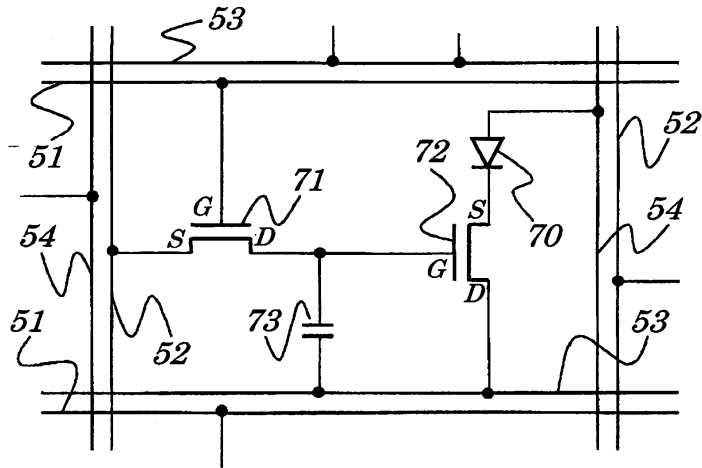

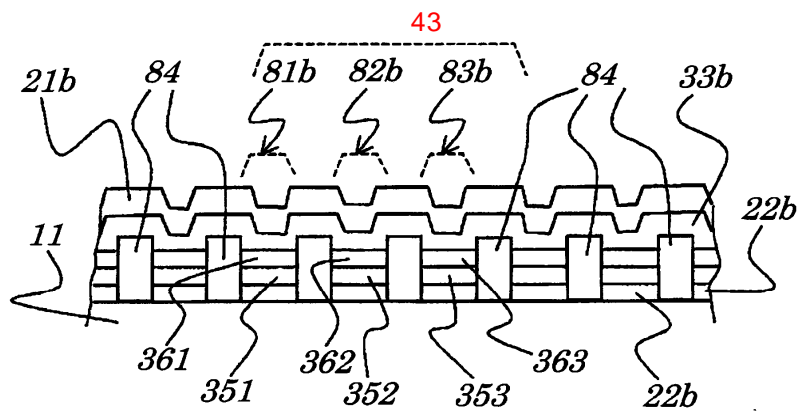
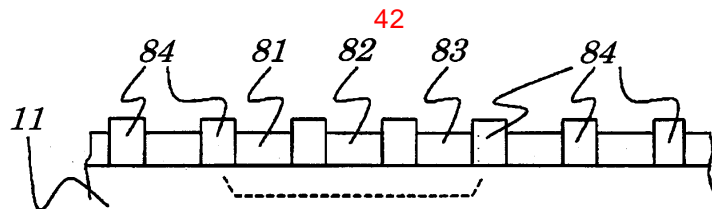
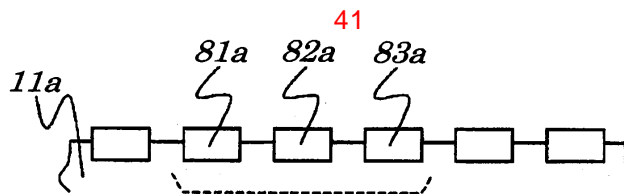
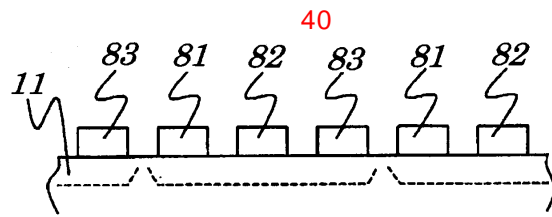
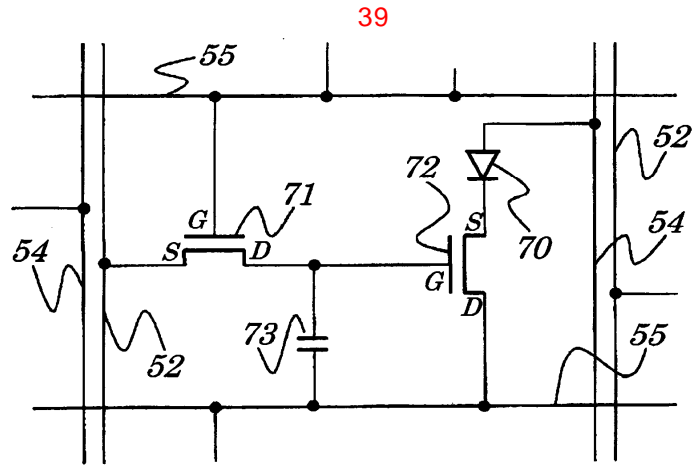

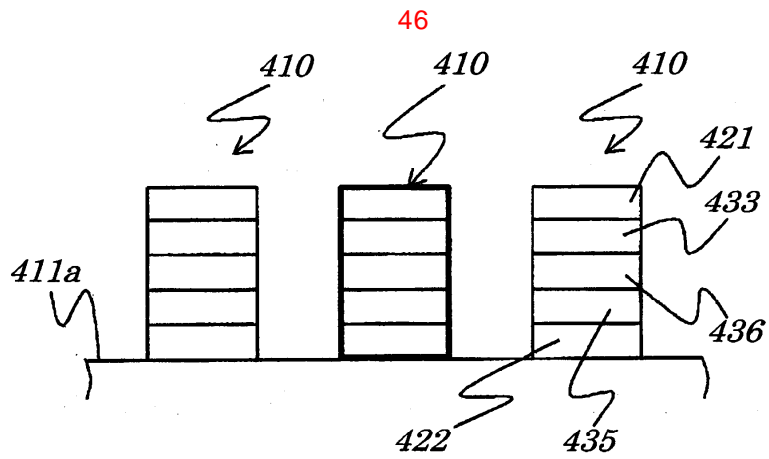
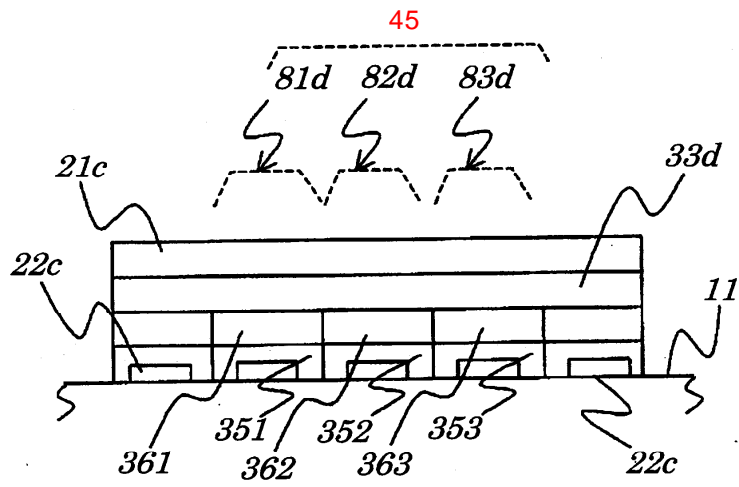
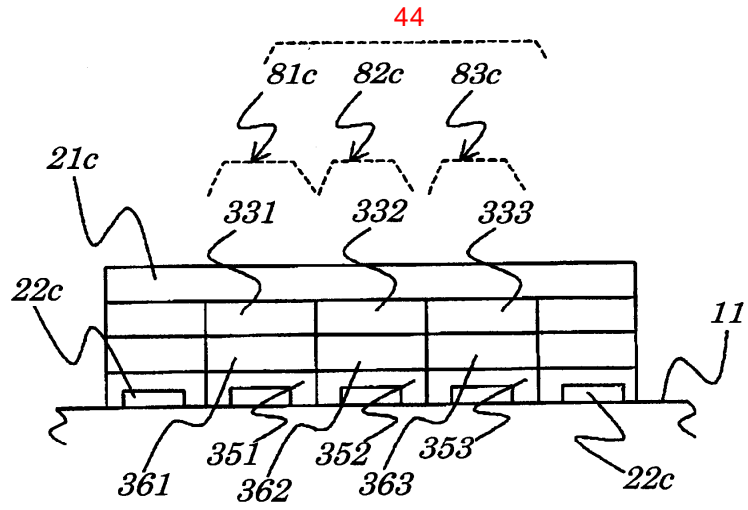

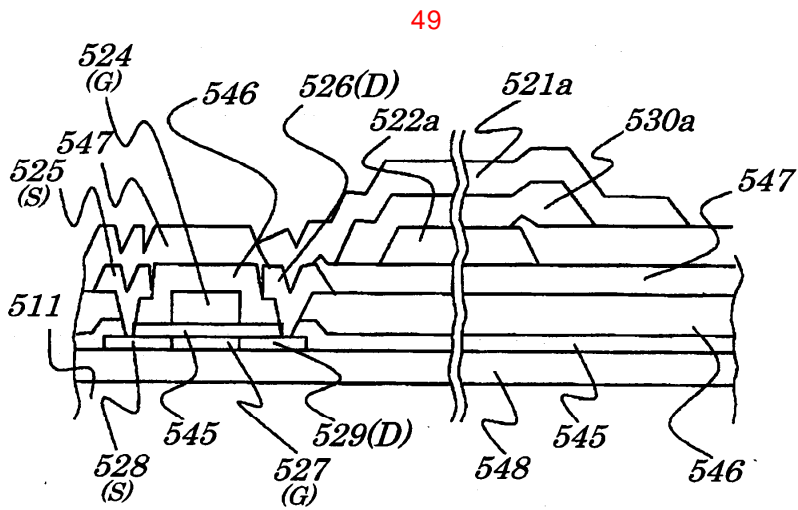
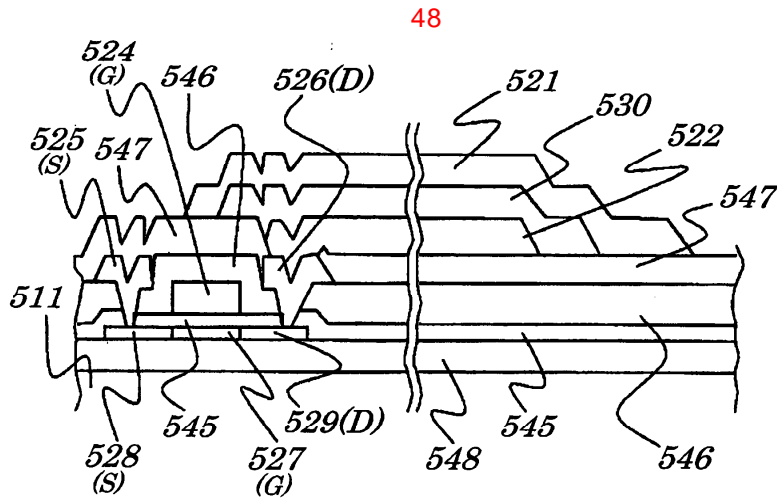
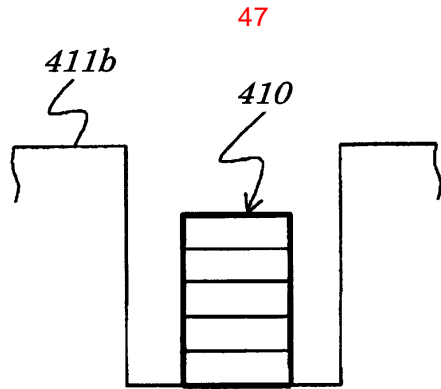

50

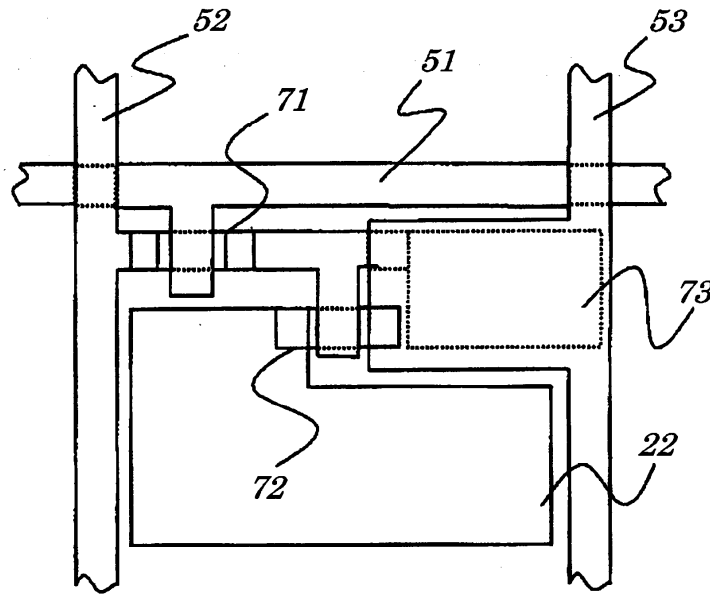

51a

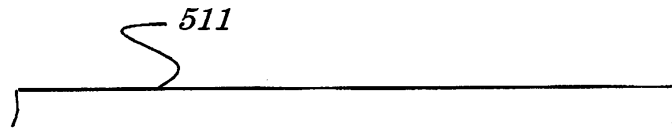

51b

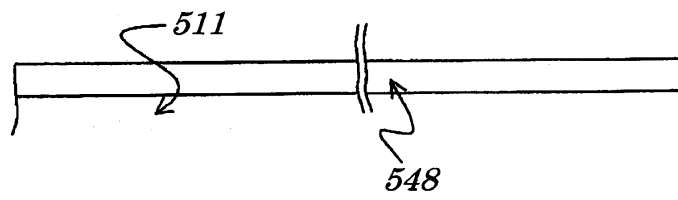

51c

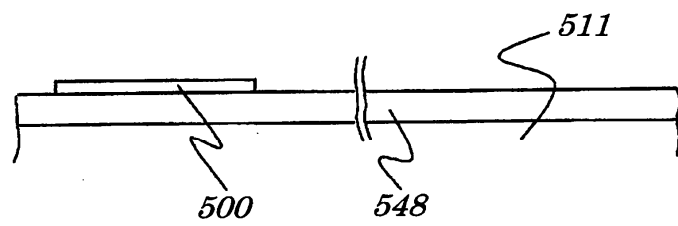

52a

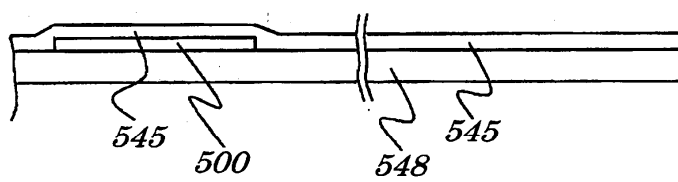

52b

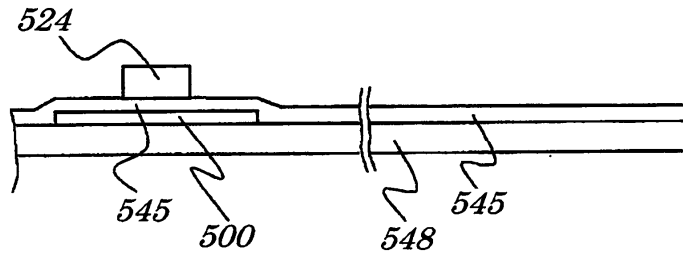

52c

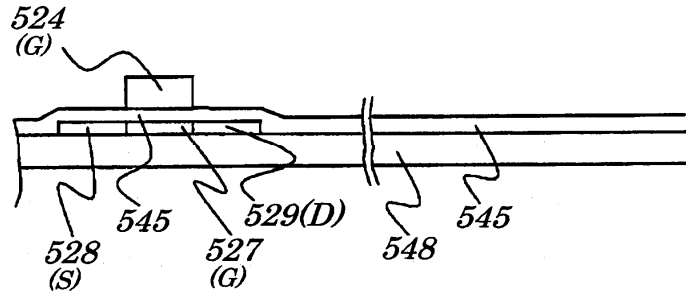

53a

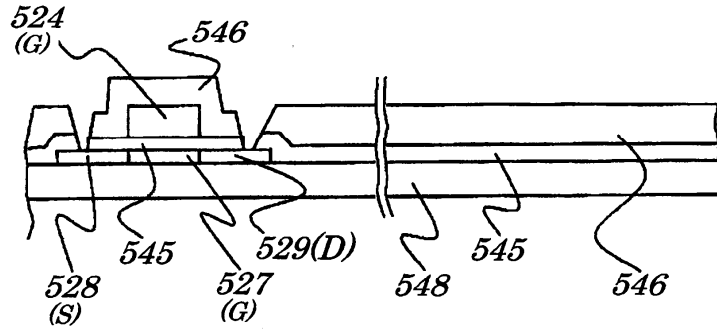

53b

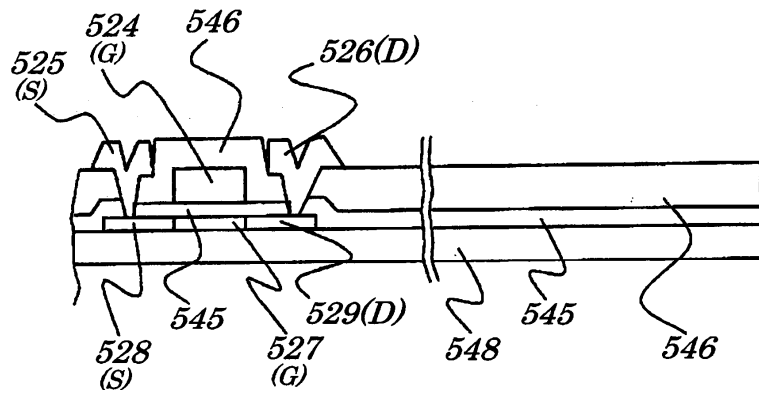

54a

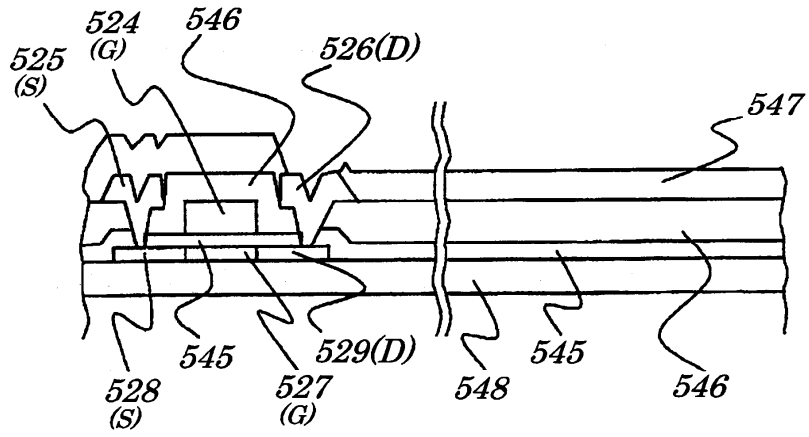

54b

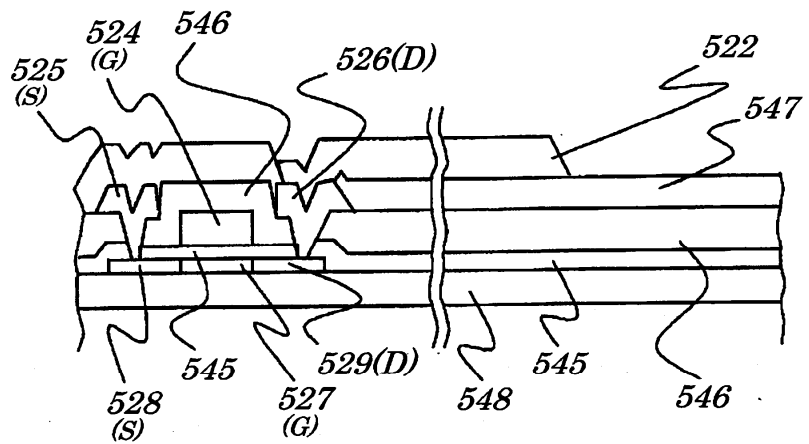

55a

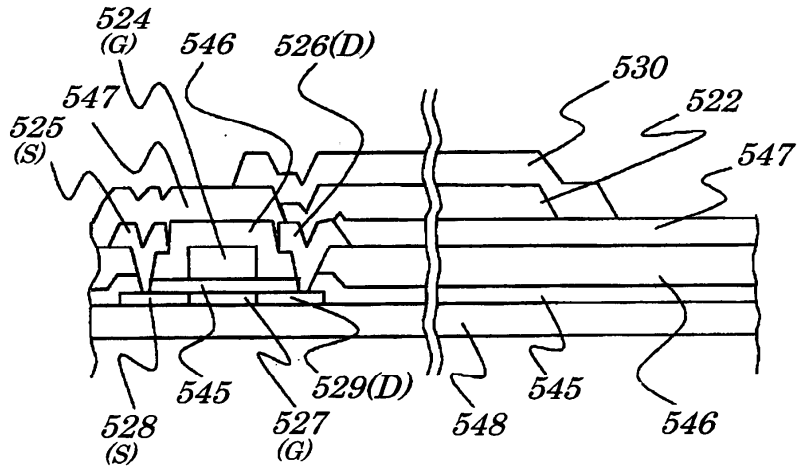

55b

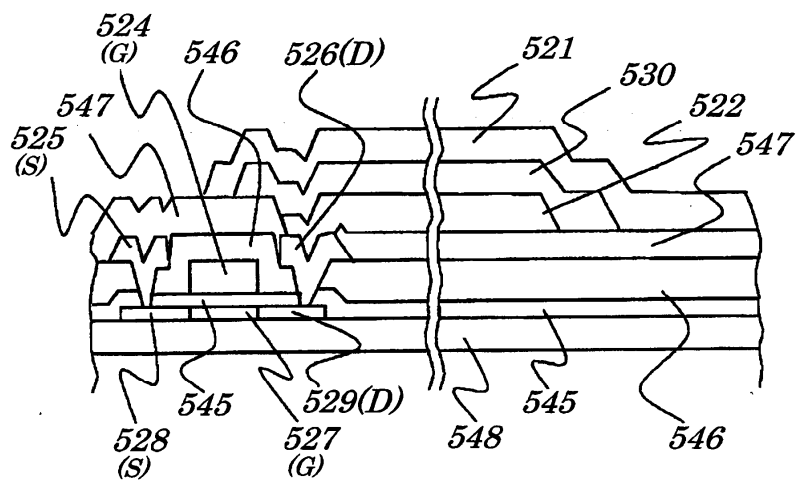

|               |   |         |            |
|---------------|---|---------|------------|
| 专利名称(译)       | 发光器件，发光器件部件和使用其的发光显示器件  |         |            |
| 公开(公告)号       | <a href="#">KR100437673B1</a>   | 公开(公告)日 | 2004-06-25 |
| 申请号           | KR1020020010687   | 申请日     | 2002-02-27 |
| 申请(专利权)人(译)   | 三星SD眼有限公司   |         |            |
| 当前申请(专利权)人(译) | 三星SD眼有限公司   |         |            |
| [标]发明人        | HAYASHI KAZUHIKO<br>하야시카주히코<br>FUKUCHI TAKASHI<br>후쿠치타카시<br>TSUBOI SHINZO<br>츠보이신조<br>FUJIEDA ICHIRO<br>후지에다이치로 |         |            |
| 发明人           | 하야시카주히코<br>후쿠치타카시<br>츠보이신조<br>후지에다이치로   |         |            |
| IPC分类号        | H01L51/50 G09G3/32 G09F9/30 H05B33/04 H01L51/52 H05B33/26 H01L27/32 H05B33/12 H01B5/14                          |         |            |
| CPC分类号        | H01L51/5237 G09G3/3233 G09G2300/0842 H01L51/5206 G09G2310/0262 H01L27/3244 H01L51/5209 H01L51/5253              |         |            |
| 代理人(译)        | PARK, 常树  |         |            |
| 优先权           | 2001051410 2001-02-27 JP  |         |            |
| 其他公开文献        | KR1020020070158A  |         |            |
| 外部链接          | <a href="#">Espacenet</a>   |         |            |

摘要(译)

提供了改善发光持续时间的有机电光(电致发光)装置,实际上使用,即发光寿命。用于有机电灯装置的发光体包括:底部电极层,其依次层压在基板上;以及发光层和透明电极层。材料In<sub>2-x</sub>Sn<sub>x</sub>O<sub>3-y</sub>称为锡和铟的氧化物的混合物,它是透明电极层的材料用作主要成分。具有吸湿性(吸湿性)的材料在透明电极层中相邻形成。电极和发光材料层应该是包括发光元件部分的电灯装置。发光器件,发光体和发光显示器件。

