

(19) World Intellectual Property Organization
International Bureau



(43) International Publication Date
4 January 2001 (04.01.2001)

PCT

(10) International Publication Number
WO 01/01384 A1

- (51) International Patent Classification⁷: G09G 3/32, 3/20 (74) Agent: WILLAMSON, Paul, L.; Internationaal Octrooibureau B.V., Prof Holstlaan 6, NL-5656 AA Eindhoven (NL).
- (21) International Application Number: PCT/EP00/05896
- (22) International Filing Date: 23 June 2000 (23.06.2000) (81) Designated States (*national*): JP, KR.
- (25) Filing Language: English (84) Designated States (*regional*): European patent (AT, BE, CH, CY, DE, DK, ES, FI, FR, GB, GR, IE, IT, LU, MC, NL, PT, SE).
- (26) Publication Language: English
- (30) Priority Data: 9914808.2 25 June 1999 (25.06.1999) GB — *Published:*
— *With international search report.*
— *Before the expiration of the time limit for amending the claims and to be republished in the event of receipt of amendments.*
- (71) Applicant: KONINKLIJKE PHILIPS ELECTRONICS N.V. [NL/NL]; Groenewoudseweg 1, NL-5621 BA Eindhoven (NL).
- (72) Inventor: YOUNG, Nigel, D.; Prof. Holstlaan 6, NL-5656 AA Eindhoven (NL).
- For two-letter codes and other abbreviations, refer to the "Guidance Notes on Codes and Abbreviations" appearing at the beginning of each regular issue of the PCT Gazette.*

(54) Title: ACTIVE MATRIX ELECTROLUMINESCENT DISPLAY DEVICE

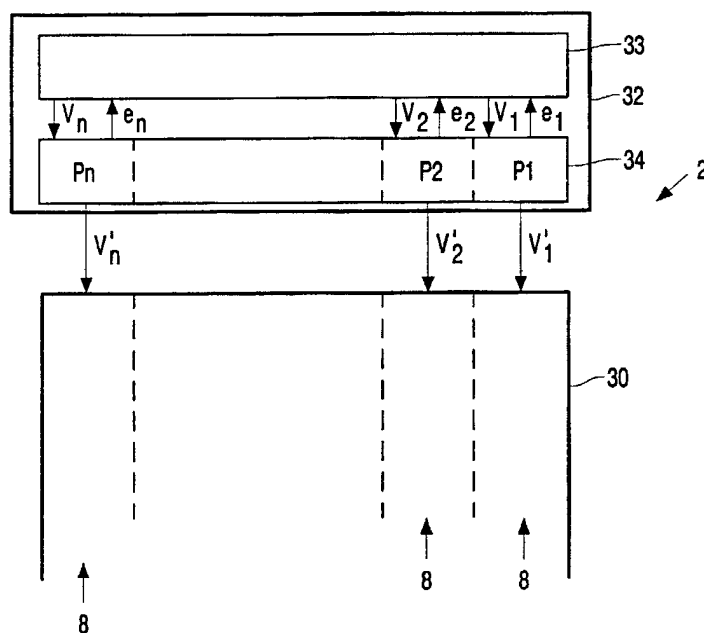

(57) Abstract: An active matrix electroluminescent display device comprises an array of display pixels (30) arranged in rows and columns with each row of pixels sharing a common line, and with currents through the display elements of a row of pixels passing along the common line. Error values (e) are generated to correct the drive signals (V) for each pixel in a row of pixels, to correct for the different voltages appearing on the common line. These different voltages give rise to horizontal cross talk. The error values (e) are derived by modelling a row of pixels, taking into account the drive signals applied to all pixels of the row. The error values result in updated drive signals (V').

ACTIVE MATRIX ELECTROLUMINESCENT DISPLAY DEVICE

This invention relates to active matrix electroluminescent display devices, comprising an array of electroluminescent display pixels arranged in rows and columns. The invention is particularly concerned with display devices in which rows of pixels share a common line, with currents through the display elements of the row passing along the common line.

Matrix display devices employing electroluminescent, light-emitting, display elements are well known. The display elements may comprise organic thin film electroluminescent elements, for example using polymer materials, or else light emitting diodes (LEDs) using traditional III-V semiconductor compounds. Recent developments in organic electroluminescent materials, particularly polymer materials, have demonstrated their ability to be used practically for video display devices. These materials typically comprise one or more layers of a semiconducting conjugated polymer sandwiched between a pair of electrodes, one of which is transparent and the other of which is of a material suitable for injecting holes or electrons into the polymer layer.

The polymer material can be fabricated using a CVD process, or simply by a spin coating technique using a solution of a soluble conjugated polymer.

Organic electroluminescent materials exhibit diode-like I-V properties, so that they are capable of providing both a display function and a switching function, and can therefore be used in passive type displays.

However, the invention is concerned with active matrix display devices, with each pixel comprising a display element and a switching device for controlling the current through the display elements. Examples of an active matrix electroluminescent display are described in US 5670792, the contents of which are incorporated herein by way of reference material.

A problem with display devices of this type arises from the fact that they have current driven display elements. Display devices of the type with which

this invention is concerned include a common line on which the currents from all pixels in a row pass. Compounding currents from the pixels in a row give rise to different voltages along the common line. These voltages depend upon the currents through all pixels in the row, since these currents all pass to the common line. These different voltages give rise to undesired changes to the outputs from the display pixels, which vary as a function of the full set of signals applied to the row. Consequently, there is cross-talk between the pixels within the row.

10

According to the invention, there is provided an active matrix electroluminescent display device comprising:

an array of display pixels arranged in rows and columns, each pixel comprising an electroluminescent display element and a switching means for controlling the current through the display element based on a signal voltage applied to the pixel, each row of pixels sharing a common line, currents through the display elements of a row of pixels passing along the common line giving rise to different voltages along the common signal line; and

driver circuitry for generating signal voltages corresponding to desired outputs from the display elements, and for applying signal voltages to rows of pixels in sequence, wherein the device further comprises:

means for generating error values for each pixel in a row of pixels to be addressed derived from modelling of a row of pixels, the modelling taking account of the signal voltages to be applied to the pixels in the row, and the error values being used to account for the different voltages on the common line;

means for updating the signal voltages for each pixel in the row of pixels to be addressed, where required, using the error values; and

means for supplying the updated signal voltages to the pixels.

The modelling of a row of pixels enables a discrepancy between the desired output and the actual output to be corrected. This discrepancy arises from the different voltages on the common line at each pixel, which depends

upon the signal voltages for the row of pixels. The device of the invention can thereby compensate for signal distortions resulting from cross-talk between pixels within a row.

5 The display element and the switching means are preferably arranged in series between a voltage supply line for the display elements and the common line, which acts as a current drain.

Each pixel may further comprise a charge storage element for holding a control voltage derived from the updated signal voltage on the switching means.

10 The invention also provides a method of driving an active matrix electroluminescent display device, comprising an array of electroluminescent display pixels arranged in rows and columns, each row of pixels sharing a common line, currents through the display elements of a row passing along the common line, different voltages thereby being present at different points along
15 the common line, the method comprising addressing rows of pixels in sequence, and for each row of pixels generating voltage signals for the pixels in the row, the generated voltage signals corresponding to desired pixel outputs, wherein the method further comprises:

generating error values derived from modelling of a row of pixels to
20 account for the different voltages on the common line, the modelling taking account of the signal voltages to be applied to the pixels in the row;

updating the signal voltages for each pixel in the row, where necessary, using the error values; and

supplying the updated signal voltages to the pixels.

25

The invention will now be described by way of example, with reference to and as shown in the accompanying drawings, in which:

Figure 1 shows part of an electroluminescent active matrix display
30 device to which the invention may be applied;

Figure 2 schematically illustrates the current flowing in a row of electroluminescent display pixels, to illustrate the cross-talk resulting from the common signal line; and

Figure 3 shows a display device according to the invention.

5 The Figures are merely schematic and have not been drawn to scale. The same reference numbers are used throughout the figures to denote the same or similar parts.

10 Figure 1 shows a known pixel configuration for an electroluminescent active matrix display device. Various types of electroluminescent display devices are known, which utilise current-controlled electroluminescent or light emitting diode display elements. An example of the construction of such a display is described in detail in US 5670792.

15 As shown schematically in Figure 1, a display device 2 comprises an array of pixels 4 arranged in rows 6 and columns 8. Each pixel 4 comprises a display element 10 and a switching element 12 in a form of a thin film transistor, which controls the operation of the display element 10 based on a signal voltage applied to the pixel 4. As one example, the display element 10
20 comprises an organic light emitting diode comprising a pair of electrodes between which one or more active layers of organic electroluminescent material is sandwiched. At least one of the electrodes is formed of a transparent material such as ITO. Various electroluminescent materials are available, for example as described in EP-A-0717446.

25 The signal voltage for a pixel is supplied via a control signal line 14 which is shared between a respective column 8 of pixels. The control signal line 14 is coupled to the gate of the switching transistor 12 through an address transistor 16. The gates for the address transistors 16 of a row 6 of pixels are coupled together to a common address line 18.

30 Each row 6 of pixels 4 also shares a common voltage supply line 20 usually provided as a continuous common electrode covering all pixels, and a common signal line 22. The display element 10 and the switching element 12

are arranged in series between the voltage supply line 20 and the common signal line 22, which acts as a current drain for the current flowing through the display element 10, as represented by arrows 24. The current flowing through the display element 10 is controlled by the switching element 12 and is a function of the gate voltage on the transistor 12, which is dependent upon the control signals supplied to the control signal line 14.

A row of pixels is selected by applying a selection pulse to the address line 18 which switches on the address transistors 16 for the respective row of pixels. A voltage level derived from the video information is applied to the control signal line 14 and is transferred by the address transistor 16 to the gate of the switching transistor 12. During the periods when a row of pixels is not being addressed by the address line 18, the address transistor 16 is turned off, but the voltage on the gate of the switching transistor 12 is maintained by a pixel storage capacitor 26 which is connected between the gate of the switching transistor 12 and the common signal line 22. The voltage between the gate of the switching transistor 12 and the common signal line 22 determines the current passing through the display element 10 of the pixel 4. Thus, the current flowing through the display element is a function of the gate-source voltage of the switching transistor 12 (the source of the transistor 12 being connected to the common signal line 22, and the drain of the transistor 12 being connected to the display element 10). This current in turn controls the light output of the pixel.

The switching transistor 12 is arranged to operate in saturation, so that the gate-source voltage governs the current flowing through the transistor, irrespectively of the drain-source voltage. Consequently, slight variations of the drain voltage do not affect the current flowing through the display element 10. The voltage on the voltage supply line 20 is therefore not critical to the correct operation of the pixels. However, voltage fluctuations on the common signal line 22, which couples together the sources of the switching transistors 12, will influence the current flowing through the display element 10 for a given control voltage on the control signal line 14.

A problem therefore arises that the resistance of the common signal line 22 gives rise to voltage drops along that line, which voltage drops are a function of the currents supplied to the line from the individual pixels 10. The voltages on the common signal line 22 at the location of different pixels will depend in a complex manner on the currents passed by all of the pixels in the row. The gate-source voltage of the switching transistor 12 will depend upon the voltage on the common signal line 22 at the location of that pixel, so that these voltage variations will affect the brightness of the pixels. The result is non-uniformity and horizontal cross-talk of the picture information shown on the display.

This invention provides an electroluminescent display device in which the control signals are modified to correct the signals applied to the display elements. The modification of the control signal is to ensure that an appropriate gate-source voltage is applied to the switching transistor 12 to give rise to the desired display element output. The voltages occurring at different points within the pixels, for example the gate and source voltages of the TFTs, are not accessible to the column driver circuitry, which generates the control signals for the control signal lines 14.

Figure 2 shows the common signal line 22 with the currents i_1, i_2, \dots, i_n associated with the pixels shown, there being n pixels in total in the row. These currents are the currents flowing through the pixels. A current summation occurs at each pixel location, as shown, and the voltage drop along each section of the common line 22 between adjacent pixels is a function of the current flowing in that section.

The currents i flowing through the pixels 10 are a function of the signal voltage applied to the control signal line. Thus:

$$i_k = f(V_k)$$

where V_k is the voltage signal applied to the control signal line 14 for that pixel.

The voltage drop between pixels 1 and 2 is therefore:

$$V_{1,2} = R.f(V_1)$$

where R is the line resistance for a section of the common signal line 22 corresponding to the pixel pitch. The value R may or may not be a constant,

depending upon the signal line design. This notation shall be used in the following.

Assuming R is constant, the voltage drop between pixels 2 and 3 is:

$$V_{2,3} = R.(f(V_1) + f(V_2))$$

5 In general:

$$V_{k,k+1} = R. \sum_{x=1}^{x=k} f(V_x)$$

Therefore, if the values of the control signals can be read, and the characteristics of the switching devices and of the display elements in the pixels can be modelled, then the voltage drops along the common signal line, and thereby the voltage at different points along the line, can be determined. The applied voltage at one end of the common line will be known.

10 For the purpose of a simplified analysis, we assume the lead out for the row is on the left, as shown in Figure 2, and that the common signal line is at the correct voltage (for example 0V) at the location of the nth pixel, because the lead-out resistance can be ignored. In this case, the voltage across the nth display element is correct. The voltage difference on the common signal line at the location of the (n-1)th pixel is:

$$V_{n-1,n} = R. \sum_{x=1}^{x=n-1} f(V_x)$$

This represents the error on the common line at pixel n-1, and thereby the amount by which the voltage across the display element is in error. For pixel n-2, the voltage drops $V_{n-1,n}$ and $V_{n-2,n-1}$ must be added.

Thus, in general, the voltage difference between the lead out voltage and the voltage on the common line at a pixel k is given by:

25
$$V_{\text{error}}(k) = \sum_{x=k}^{x=n-1} V_{x,x+1}$$

for all values of K from 1 to n-1, and with $V_{\text{error}}(n)=0$.

The error value for each pixel can be calculated and can be used to compensate for the voltage drops along the common line. In the case of the pixel configuration of Figure 1, this error value represents the amount by which

the source voltage of the switching transistor 12 is too high. To compensate for this, the gate voltage needs to be increased by the same amount, in order to return to the correct gate-source voltage, which dictates the current flowing through the display elements, and thereby the brightness.

5 The voltage applied to the control signal line can then be modified by:

$$V'_k = V_k + V_{\text{error}(k)}$$

Figure 3 shows a display device according to the invention. The device 2 comprises a display area 30 which comprises pixels, for example as shown in Figure 1. Driver circuitry 32 is provided which includes a conventional column driver unit 33 for generating signal voltages $V_1, V_2 \dots V_n$ corresponding to desired outputs from the display elements. These signal values are determined from a video input signal to the display device which originates from separate circuitry and which arranges the data into a standard format. In accordance with the invention, the driver circuitry 32 includes an additional circuit 34 to which the signals $V_1, V_2 \dots V_n$ are applied. Error values shown as $e_1, e_2, \dots e_n$ (corresponding to V_{error}) are generated within the circuit 34 to enable updated signal voltages $V'_1, V'_2 \dots V'_n$ to be supplied to the pixels in the display area 30. The additional circuit 34 may comprise a line store for the values V and a computation unit for generating the error values from them.

20 The error values are obtained from modelling of a row of pixels to account for the different voltages on the common signal line. As described above, this modelling may take account of the characteristics of the switching transistor and/or of the display element as well as of the common line 22.

The error values enable the updated signal voltages V' to take account of the different voltages on the common signal line 22 at each pixel, which voltages will depend upon the signal voltages for the full row of pixels. In this way, the updated signal voltages V' enable cross-talk between the pixels in a display area to be eliminated.

30 In the analysis above, it is assumed that the lead-out resistance is negligible. In practice, there will of course be a voltage drop at the lead-out of the common line and which will be proportional to the total current flowing, and can therefore also be modelled. Furthermore, numerical errors in the

modelling may be corrected by measuring the voltage drops across a line during a calibration of the modelling device.

Although a specific pixel configuration has been shown, various other pixel configurations will be apparent to those skilled in the art, and devices using those pixel configurations will benefit from the present invention, provided each row of pixels shares a common line, and in which the voltages at different points along this line may influence the output of the display elements.

CLAIMS

1. An active matrix electroluminescent display device comprising:
an array of display pixels arranged in rows and columns, each pixel
5 comprising an electroluminescent display element and a switching means for
controlling the current through the display element based on a signal voltage
applied to the pixel, each row of pixels sharing a common line, currents
through the display elements of a row of pixels passing along the common line
giving rise to different voltages along the common signal line; and
10 driver circuitry for generating signal voltages corresponding to desired
outputs from the display elements, and for applying signal voltages to rows of
pixels in sequence, characterised in that the device further comprises:
means for generating error values for each pixel in a row of pixels to be
addressed derived from modelling of a row of pixels, the modelling taking
15 account of the signal voltages to be applied to the pixels in the row, and the
error values being used to account for the different voltages on the common
line;
means for updating the signal voltages for each pixel in the row of pixels
to be addressed, where required, using the error values; and
20 means for supplying the updated signal voltages to the pixels.
2. A device as claimed in claim 1, wherein the display element and the
switching means are arranged in series between a voltage supply line for the
display elements and the common line, which acts as a current drain.
25
3. A display as claimed in claim 2, wherein an address line is associated
with each row of pixels, and each pixel comprises an addressing switch which
is controlled by the address line for switching the updated signal voltages to
the switching means.
30

4. A display as claimed in any preceding claim, wherein each pixel further comprises a charge storage element for holding a control voltage derived from the updated signal voltage on the switching means.
- 5 5. A display as claimed in any preceding claim, wherein the modelling includes modelling of the resistance per unit length of the common line and of the currents flowing along the common line as a result of the signal voltages applied to the display elements.
- 10 6. A method of driving an active matrix electroluminescent display device comprising an array of electroluminescent display pixels arranged in rows and columns, each row of pixels sharing a common line, currents through the display elements of a row passing along the common line, different voltages thereby being present at different points along the common line, the method
15 comprising addressing rows of pixels in sequence, and for each row of pixels generating voltage signals for the pixels in the row, the generated voltage signals corresponding to desired pixel outputs, characterised in that the method further comprises:
- generating error values derived from modelling of a row of pixels to
20 account for the different voltages on the common line, the modelling taking account of the signal voltages to be applied to the pixels in the row;
 - updating the signal voltages for each pixel in the row, where required, using the error values; and
 - supplying the updated signal voltages to the pixels.

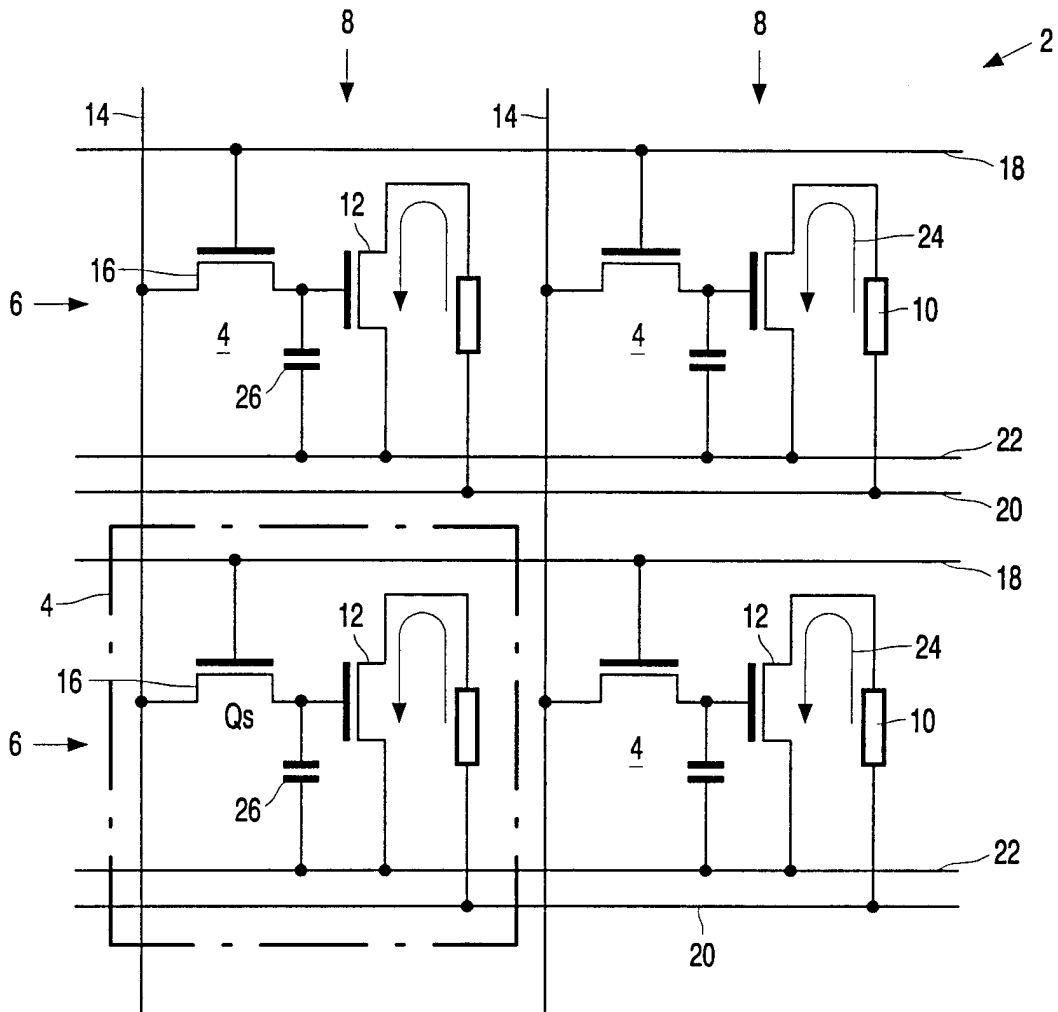

FIG. 1

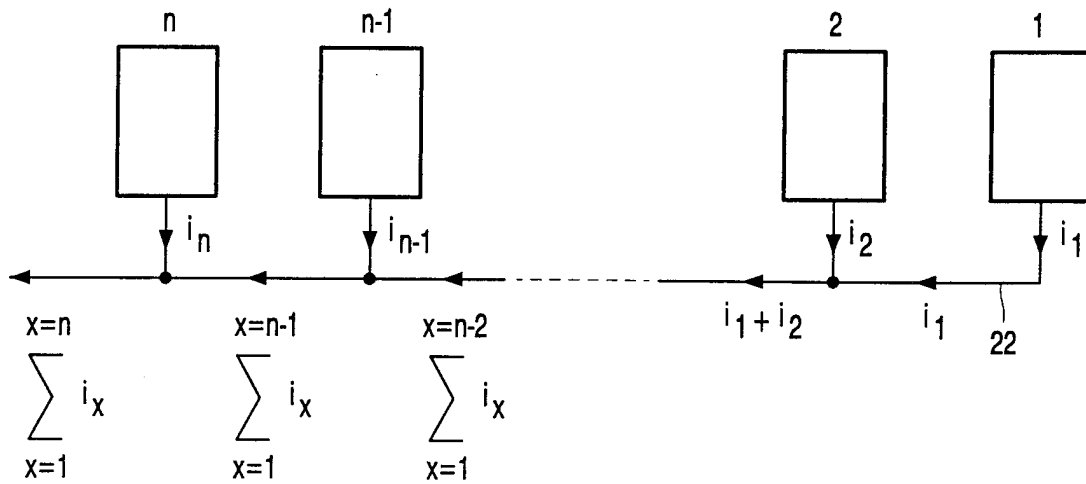

FIG. 2

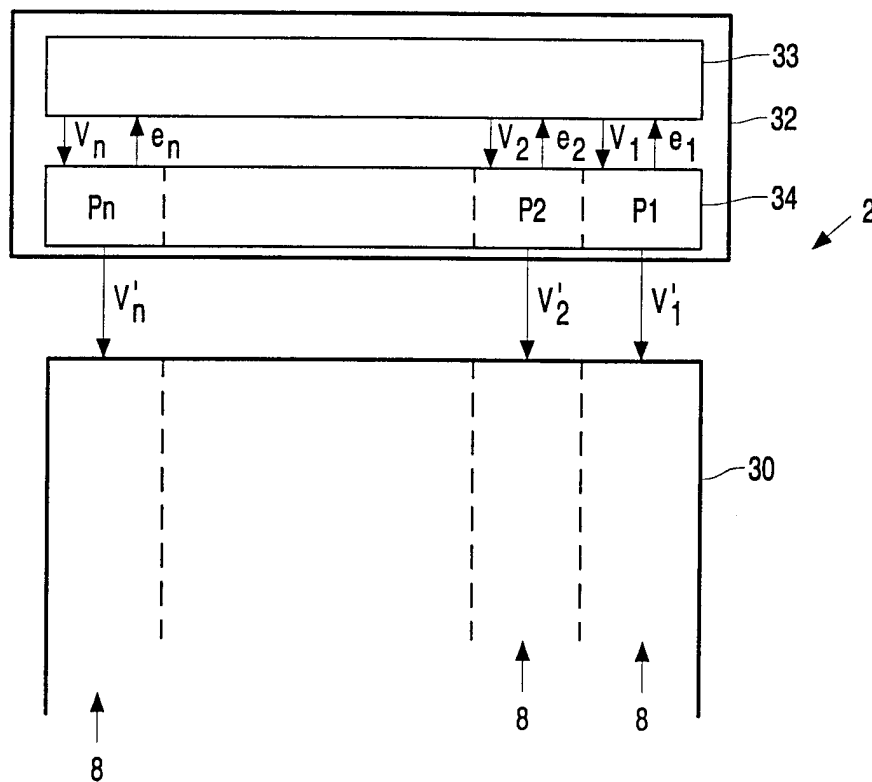

FIG. 3

INTERNATIONAL SEARCH REPORT

Intern: al Application No
PCT/EP 00/05896

A. CLASSIFICATION OF SUBJECT MATTER
IPC 7 G09G3/32 G09G3/20

According to International Patent Classification (IPC) or to both national classification and IPC

B. FIELDS SEARCHED

Minimum documentation searched (classification system followed by classification symbols)
IPC 7 G09G

Documentation searched other than minimum documentation to the extent that such documents are included in the fields searched

Electronic data base consulted during the international search (name of data base and, where practical, search terms used)
EPO-Internal, WPI Data, PAJ

C. DOCUMENTS CONSIDERED TO BE RELEVANT

Category °	Citation of document, with indication, where appropriate, of the relevant passages	Relevant to claim No.
A	US 5 714 968 A (IKEDA NAOYASU) 3 February 1998 (1998-02-03) column 5, line 14 - line 47; figure 2 column 7, line 54 -column 8, line 7; figure 8	1-4,6
A	EP 0 686 993 A (CANON KK) 13 December 1995 (1995-12-13) page 4, line 16 - line 33 page 8, line 18 -page 10, line 18 page 17, line 38 -page 19, line 18	1,6

Further documents are listed in the continuation of box C. Patent family members are listed in annex.

° Special categories of cited documents :

<p>"A" document defining the general state of the art which is not considered to be of particular relevance</p> <p>"E" earlier document but published on or after the international filing date</p> <p>"L" document which may throw doubts on priority claim(s) or which is cited to establish the publication date of another citation or other special reason (as specified)</p> <p>"O" document referring to an oral disclosure, use, exhibition or other means</p> <p>"P" document published prior to the international filing date but later than the priority date claimed</p>	<p>"T" later document published after the international filing date or priority date and not in conflict with the application but cited to understand the principle or theory underlying the invention</p> <p>"X" document of particular relevance; the claimed invention cannot be considered novel or cannot be considered to involve an inventive step when the document is taken alone</p> <p>"Y" document of particular relevance; the claimed invention cannot be considered to involve an inventive step when the document is combined with one or more other such documents, such combination being obvious to a person skilled in the art.</p> <p>"&" document member of the same patent family</p>
--	--

Date of the actual completion of the international search <p style="text-align: center;">16 October 2000</p>	Date of mailing of the international search report <p style="text-align: center;">23/10/2000</p>
---	---

Name and mailing address of the ISA European Patent Office, P.B. 5818 Patentlaan 2 NL - 2280 HV Rijswijk Tel. (+31-70) 340-2040, Tx. 31 651 epo nl, Fax: (+31-70) 340-3016	Authorized officer <p style="text-align: center;">Amian, D</p>
--	---

INTERNATIONAL SEARCH REPORT

Information on patent family members

International Application No PCT/EP 00/05896

Patent document cited in search report	A	Publication date	Patent family member(s)	Publication date
US 5714968	A	03-02-1998	JP 2689916 B	10-12-1997
			JP 8054835 A	27-02-1996
			JP 2689917 B	10-12-1997
			JP 8054836 A	27-02-1996
			US 6011529 A	04-01-2000
			US 5940053 A	17-08-1999
EP 0686993	A	13-12-1995	JP 8248920 A	27-09-1996
			AT 173356 T	15-11-1998
			AU 703968 B	01-04-1999
			AU 2054995 A	04-01-1996
			AU 2501099 A	01-07-1999
			CA 2151202 A	09-12-1995
			CN 1125893 A	03-07-1996
			DE 69505890 D	17-12-1998
			DE 69505890 T	12-05-1999
			JP 8248921 A	27-09-1996
			KR 170470 B	30-03-1999
			US 5734361 A	31-03-1998

专利名称(译)	有源矩阵电致发光显示装置		
公开(公告)号	EP1116205A1	公开(公告)日	2001-07-18
申请号	EP2000943891	申请日	2000-06-23
[标]申请(专利权)人(译)	皇家飞利浦电子股份有限公司		
申请(专利权)人(译)	皇家飞利浦电子N.V.		
当前申请(专利权)人(译)	皇家飞利浦电子N.V.		
[标]发明人	YOUNG NIGEL D		
发明人	YOUNG, NIGEL, D.		
IPC分类号	H01L51/50 G09G3/20 G09G3/30 G09G3/32		
CPC分类号	G09G3/2011 G09G3/32 G09G3/3233 G09G3/3291 G09G2300/0842 G09G2320/0209 G09G2320/0223		
优先权	1999014808 1999-06-25 GB		
其他公开文献	EP1116205B1		
外部链接	Espacenet		

摘要(译)

有源矩阵电致发光显示装置包括以行和列布置的显示像素阵列 (30) , 每行像素共享公共线, 并且电流通过沿着公共线传递的一行像素的显示元件。产生误差值 (e) 以校正一行像素中的每个像素的驱动信号 (V) , 以校正出现在公共线上的不同电压。这些不同的电压引起水平串扰。通过对一行像素建模, 考虑应用于该行的所有像素的驱动信号, 导出误差值 (e) 。误差值导致更新的驱动信号 (V_{更新}) 。