



(11) **EP 1 580 824 B1**

(12) **EUROPEAN PATENT SPECIFICATION**

(45) Date of publication and mention of the grant of the patent:  
**14.05.2008 Bulletin 2008/20**

(51) Int Cl.:  
**H01L 51/52<sup>(2006.01)</sup> H01L 51/56<sup>(2006.01)</sup>**

(21) Application number: **05005803.1**

(22) Date of filing: **17.03.2005**

(54) **Organic electro-luminescence display device and method of fabricating the same**

Organische elektrolumineszente Anzeigevorrichtung und deren Herstellungsverfahren

Dispositif d'affichage par électroluminescence organique et méthode de fabrication dudit dispositif

(84) Designated Contracting States:  
**AT BE BG CH CY CZ DE DK EE ES FI FR GB GR HU IE IS IT LI LT LU MC NL PL PT RO SE SI SK TR**

• **Ju, Jae Hyoung**  
**Dalseo-gu**  
**Daegu (KR)**

(30) Priority: **23.03.2004 KR 2004019684**

(74) Representative: **Rupprecht, Kay et al**  
**Meissner, Bolte & Partner GbR**  
**Postfach 10 26 05**  
**86016 Augsburg (DE)**

(43) Date of publication of application:  
**28.09.2005 Bulletin 2005/39**

(73) Proprietor: **LG ELECTRONICS INC.**  
**Seoul (KR)**

(56) References cited:  
**EP-A1- 0 888 035 WO-A-03/026012**  
**WO-A-03/075616**

(72) Inventors:  
• **Jung, Young Ro**  
**Gumi-si**  
**Gyeongsangbuk-do (KR)**

• **PATENT ABSTRACTS OF JAPAN vol. 1998, no. 09, 31 July 1998 (1998-07-31) -& JP 10 106751 A (NEC CORP), 24 April 1998 (1998-04-24)**

**EP 1 580 824 B1**

Note: Within nine months from the publication of the mention of the grant of the European patent, any person may give notice to the European Patent Office of opposition to the European patent granted. Notice of opposition shall be filed in a written reasoned statement. It shall not be deemed to have been filed until the opposition fee has been paid. (Art. 99(1) European Patent Convention).

**Description**

[0001] This application claims the benefit of Korean Patent Application No. P2004-19684 filed in Korea on March 23, 2004.

**BACKGROUND OF THE INVENTION****FIELD OF THE INVENTION**

[0002] This invention relates to a method of fabricating an organic electro-luminescence display device that is capable of reducing an inverse taper of a bus electrode. A display device and a method of this type is known from Patent Abstracts of Japan 10-106751 and from European Patent Application EP-A1-0 888 035.

**DESCRIPTION OF THE RELATED ART**

[0003] Recently, there have been developed various flat panel display devices reduced in weight and bulk that is capable of eliminating disadvantages of a cathode ray tube (CRT). Such flat panel display devices include a liquid crystal display (LCD), a field emission display (FED) device, a plasma display panel (PDP) and an electroluminescence (EL) display device, etc. device. Especially, the EL display device has characteristics of a wide viewing angle, a high aperture rate and a high color purity, etc., such that it can be highlighted into a post-generation display device.

[0004] Such the EL display device comprises an anode electrode and a cathode electrode with an organic layer therebetween, wherein the organic layer includes a hole carrier layer, a light-emitting layer, and an electron carrier layer. Electrons and holes emitted from these anode electrode and cathode electrode are re-combined with each other, thereby generating a visible light. At this time, the generated visible light is emitted, via the anode electrode, into an exterior to thereby display a predetermined picture or image.

[0005] Meanwhile, as shown in FIG. 1, an anode electrode 52 includes: a transparent 56 formed on a substrate 51; and a bus electrode 54 formed on one side of the transparent electrode 56 to compensate a resistance component of the transparent electrode 56.

[0006] Herein, the bus electrode 54 is formed by etching a chrome Cr, a molybdenum Mo, and a copper Cu, etc. using an etchant consisted of phosphoric acid in a range of 60 to 65 weight %, nitric acid in a range of 5 to 6 weight %, acetic acid of 10 weight %, and water in a range of 19 to 25 weight %. An inclination angle of the bus electrode 54 formed by using the etchant is relatively large as about 80° to 110°. Accordingly, a taper of the bus electrode 54 is deteriorated. In other words, the bus electrode 54 is formed in an inverse taper type in which the lower portion thereof has a narrower width than the upper portion thereof. An insulating film 58 formed to cover the anode electrode 52 having the bus electrode 54 makes a step coverage to be deteriorated, so that a pinhole A exposing the bus electrode 54 is occurred as shown in FIG. 2. An insulation breakdown is occurred by the pinhole, so that there is a problem that a reliance of the electro-luminescence display device is deteriorated, e.g., the anode electrode 52 and a cathode electrode are shorted.

**SUMMARY OF THE INVENTION**

[0007] Accordingly, it is an object of the present invention to provide a method of fabricating an organic electro-luminescence display device that is capable of reducing an inverse taper of a bus electrode.

[0008] In order to achieve these and other objects of the invention, an organic electro-luminescence display device comprises: an anode electrode including a transparent electrode and a bus electrode; a cathode electrode crossing the anode electrode; and an organic layer located at a cross both the anode electrode and the cathode electrode, wherein the bus electrode has an inclination angle of 30° to 70°.

[0009] The bus electrode has an inclination angle of 30° to 50°.

[0010] The anode electrode includes: the transparent electrode; and the bus electrode located on the transparent electrode.

[0011] The anode electrode includes: the bus electrode; and the transparent electrode located on the bus electrode.

[0012] In order to achieve these and other objects of the invention, a method of fabricating an organic electro-luminescence display device comprises: forming an anode electrode including a transparent electrode and a bus electrode on a substrate; forming an organic layer generating light on the substrate having the anode electrode; and forming a cathode electrode crossing the anode electrode on the substrate having the organic layer, wherein the bus electrode has an inclination angle of 30° to 70°.

[0013] The bus electrode has an inclination angle of 30° to 50°.

[0014] The forming the anode electrode having the transparent electrode and the bus electrode on the substrate includes: forming the transparent electrode on the substrate; and forming the bus electrode having the inclination angle

of 30° to 70° on the transparent electrode.

[0015] The forming the anode electrode having the transparent electrode and the bus electrode on the substrate includes: forming the bus electrode having the inclination angle of 30° to 70° on the substrate; and forming the transparent electrode so as to contact with the bus electrode on the substrate having the bus electrode.

[0016] The forming the bus electrode having the inclination angle of 30° to 70° includes: depositing a metal on the substrate; and patterning the metal by a photolithography process and an etching process using an etchant to form the bus electrode.

[0017] The etchant is consisted of phosphoric acid in a range of 55 to 60 weight %, nitric acid in a range of 10 to 12 weight %, acetic acid in a range of 8 to 10 weight %, and water in a range of 18 to 27 weight %.

[0018] The etchant has a temperature of a normal temperature to 45°C.

[0019] The etchant has a temperature of 30°C to 35°C.

[0020] The metal includes at least one of chrome, molybdenum, and copper.

## BRIEF DESCRIPTION OF THE DRAWINGS

[0021] These and other objects of the invention will be apparent from the following detailed description of the embodiments of the present invention with reference to the accompanying drawings, in which:

[0022] FIG. 1 is a perspective view illustrating an anode electrode of a related art organic electro-luminescence display device;

[0023] FIG. 2 is a sectional view illustrating a pinhole phenomenon of an insulating film by a bus electrode shown in FIG. 1;

[0024] FIG. 3 is a plan view illustrating an organic electro-luminescence display device;

[0025] FIG. 4 is a sectional view illustrating the organic electro-luminescence display device taken along a line II-II' in FIG. 3;

[0026] FIG. 5 is a sectional view illustrating the organic electro-luminescence display device taken along a line III-III' in FIG. 3;

[0027] FIGs. 6A to 6F are plan views and sectional views representing a method of manufacturing the organic electro-luminescence display device according to the present invention; and

[0028] FIGs. 7A and 7B are sectional views illustrating a taper angle of a bus electrode in accordance with a temperature of an etchant.

## DETAILED DESCRIPTION OF THE PREFERRED EMBODIMENT

[0029] Reference will now be made in detail to the preferred embodiments of the present invention, examples of which are illustrated in the accompanying drawings.

[0030] Hereinafter, the preferred embodiments of present invention will be described in detail with reference to the FIGs. 3 to 7B.

[0031] FIG. 3 is a plan view illustrating an organic electro-luminescence display device and FIG. 4 is a sectional view illustrating the organic electro-luminescence display device taken along a line II-II' in FIG. 3.

[0032] Referring to FIGs. 3 and 4, the related art electro-luminescence display device includes an insulating film 6, a barrier rib 8, and an organic layer 10 formed between an anode electrode 4 and a cathode electrode 12, which are insulated from each other and crossing each other on a substrate 2.

[0033] A plurality of anode electrodes 4 is provided on the substrate 2 in such a manner to be spaced at a predetermined distance from each other. A first driving signal is supplied to such the anode electrode 4 in order to emit an electron (or hole).

[0034] As shown in FIG. 5, the anode electrode 4 includes: a transparent electrode 4a made of a transparent conductive material, e.g., indium-tin-oxide ITO, etc., on a substrate 2; and a bus electrode 4b made of chrome Cr, molybdenum Mo, copper Cu, and etc. on one side of the transparent electrode 4a to compensate a resistance component of the transparent electrode 4a. Furthermore, the anode electrode 4 may include: a bus electrode 4b formed on a substrate 2; and a transparent electrode 4a formed on the substrate 2 having the bus electrode 4b.

[0035] Herein, the bus electrode 4b is formed to have a relatively smooth inclination angle of about 30° to 70° from the substrate 2. Preferably, the bus electrode 4b is formed to have the inclination angle of about 30° to 50° from the substrate 2.

[0036] The insulating film 6 is formed in a lattice type so as to expose an aperture for each EL cell area on the substrate 2 having the anode electrode 4.

[0037] The barrier rib 8 is formed in a direction crossing the anode electrode 4, and is formed in parallel to the cathode electrode 12 by a predetermined distance to partition adjacent EL cells. In other words, the barrier rib 8 separates the organic layers 10 from each other and the cathode electrodes 12 from each other between the adjacent EL cells. Further, the barrier rib 8 has an overhang structure in which the upper portion thereof has a larger width than the lower portion

thereof.

[0038] The organic layer 10 is made of an organic compound on the insulating film 6. In other words, the organic layer 10 is formed by depositing a hole carrier layer, a light-emitting layer and an electron carrier layer onto the insulating film 6.

[0039] A plurality of cathode electrodes 12 is provided on the organic layer 10 in such a manner to be spaced at a predetermined distance from each other, and in such a manner to be crossed with the anode electrodes 4. A second driving signal is supplied to the cathode electrode 12 in order to emit a hole (or electron)

[0040] As set forth above, in the organic electro-luminescence display device according to the present, the bus electrode 4b is formed to have an inclination angle of 30° to 70°. Accordingly, a taper of the bus electrode 4b having a relatively smooth inclination angle becomes improved, so that a step coverage of the insulating film 6 formed to cover the bus electrode 4b becomes improved. Thus, it is possible to prevent an insulation breakdown.

[0041] FIGs. 6A to 6F are plan views and sectional views representing a method of manufacturing the organic electro-luminescence display device according to the present invention.

[0042] Firstly, a transparent conductive material, e.g., indium-tin-oxide, etc., is deposited and then patterned on a substrate 2, to thereby form a transparent electrode 4a of an anode electrode on the substrate as shown in FIG. 6.

[0043] Chrome Cr or Molybdenum Mo, etc. is deposited on the substrate 2 having the transparent electrode 4a and then is patterned by a photolithography process and an etching process using an etchant consisted of phosphoric acid in a range of 55 to 60 weight %, nitric acid in a range of 10 to 12 weight %, acetic acid in a range of 8 to 10 weight %, and water in a range of 18 to 27 weight %, to thereby form a bus electrode 4b of an anode electrode having a taper angle of 30° to 70° as shown in FIG. 6B. The etching process of the bus electrode 4b will be described in detail later.

[0044] A photosensitive insulating material is deposited and then patterned on the substrate 2 having the anode electrode 4, to thereby form a insulating film 6 as shown in FIG. 6C. The insulating film 6 is formed in a lattice type at an entire portion except for a light-emitting portion.

[0045] A photosensitive insulating material is deposited and then patterned on the substrate 2 having the insulating film 6, to thereby form a barrier rib 8 as shown in FIG. 6D. The barrier rib 8 is formed with a predetermined distance from adjacent barrier ribs in a direction crossing the anode electrode 4, and is formed at a non-light emitting portion.

[0046] An organic layer 10 is formed on the substrate having the barrier rib 8 as shown in FIG. 6E. The organic layer 10 includes hole carrier layer, a light emitting layer, and an electron carrier layer.

[0047] A cathode electrode 12 is formed on the substrate 2 having the organic layer 10 as shown in FIG. 6F. At this time, the cathode electrode 12 is entirely deposited to be formed, but is separated for each EL cell by the barrier rib having a relatively high height to be formed.

[0048] The bus electrode 4b of the anode electrode is formed with result that a metal such as chrome Cr, molybdenum Mo, copper Cu, etc. is etched by an anisotropic etching manner using an etchant consisted of compositions shown in table 1, at a temperature of a normal temperature to 45°C, preferably temperature of about 30°C to 35°C. The bus electrode 4b formed by the etching manner using the etchant has an inclination angle of 30° to 70°.

Table 1

	Phosphoric acid	Nitric acid	Acetic acid	Water
Composition content (weight%)	55 to 60	10 to 12	8 to 10	18 to 28

[0049] As shown in Table 1, a content of nitric acid becomes larger by about double amount than that of the related art, so that an etching speed of a metal making the bus electrode 4b becomes slower. Accordingly, the bus electrode 4b can be formed with a smaller inclination angle.

[0050] Meanwhile, an etching amount and inclination angle of the bus electrode 4b formed by the etchant shown in Table 1 are differentiated depending upon a temperature of the etchant as shown in Table 2.

Table 2

Temperature of etchant (°C)	first location	second location	third location	Inclination angle of bus angle of bus electrode
30°C	0.20μm	0.21μm	0.28μm	40°C to 49°C
40°C	0.54μm	0.44μm	0.52μm	54 °C to 63 °C

[0051] In a case that a temperature of the etchant is 40°C, the bus electrode 4b located at a first location(near upper corner of right side in the substrate) is etched by about 0.54 μm from end of a photo-resist pattern 30 formed by an etching process and a developing process as shown in FIG. 7A, the bus electrode 4b located at a second location(near

center of the substrate) is etched by about 0.44  $\mu\text{m}$  from end of the photo-resist pattern 30, and the bus electrode 4b located at a third location (near lower corner of left side of the substrate) is etched by about 0.52  $\mu\text{m}$  from end of the photo-resist pattern 30. As set forth above, when the temperature of the etchant is 40°C, the bus electrode 4b is over-etched by a first width d1 from end of the photo-resist pattern 30 and the bus electrode 4b has a inclination angle  $\alpha$  of about 54° to 63°.

**[0052]** On the other hand, in a case that a temperature of the etchant is 30°C, the bus electrode 4b located at a first location (near upper corner of right side in the substrate) is etched by about 0.20  $\mu\text{m}$  from end of a photo-resist pattern 30 formed by an etching process and a developing process as shown in FIG. 7B, the bus electrode 4b located at a second location (near center of the substrate) is etched by about 0.21  $\mu\text{m}$  from end of the photo-resist pattern 30, and the bus electrode 4b located at a third location (near lower corner of left side of the substrate) is etched by about 0.28  $\mu\text{m}$  from end of the photo-resist pattern 30. As set forth above, when the temperature of the etchant is 30°C, the bus electrode 4b is over-etched by a second width shorter than the first width d1, from end of the photo-resist pattern 30, and the bus electrode 4b has a inclination angle  $\beta$  of about 40° to 49°.

**[0053]** As set forth above, when the temperature of the etchant is 30°C as compared with 40°C, an over-etched amount of the bus electrode 4b is a relatively small and inclination angle of the bus electrode 4b becomes relatively smaller.

## Claims

1. A method of fabricating an organic electro-luminescence display device comprising;

forming an anode electrode (4) including a transparent electrode (4a) and a bus electrode (4b) on a substrate (2);  
forming an organic layer (10) generating light on the substrate (2) having the anode electrode (4); and  
forming a cathode electrode (12) crossing the anode electrode on the substrate (2) having the organic layer (10), wherein  
the bus electrode (4b) has an inclination angle of 30° to 70° from the substrate (2), and

wherein forming the anode electrode (4) having the transparent electrode (4a) and the bus electrode (4b) on the substrate includes:

forming the transparent electrode (4a) on the substrate (2);  
forming the bus electrode (4b) having the inclination angle of 30° to 70° on the transparent electrode (4a);  
wherein the bus electrode (4b) is formed by patterning a metal deposited on the substrate using a photolithography process and an etching process using an etchant; and

**characterized in that** the etchant consists of phosphoric acid in a range of 55 to 60 weight %, nitric acid in a range of 10 to 12 weight %, acetic acid in a range of 8 to 10 weight %, and water in a range of 18 to 27 weight %.

2. A method of fabricating an organic electro-luminescence display device comprising:

forming an anode electrode (4) including a transparent electrode (4a) and a bus electrode (4b) on a substrate (2);  
forming an organic layer (10) generating light on the substrate (2) having the anode electrode (4); and  
forming a cathode electrode (12) crossing the anode electrode on the substrate (2) having the organic layer (10), wherein  
the bus electrode (4b) has an inclination angle of 30° to 70° from the substrate (2), and

wherein forming the anode electrode (4) having the transparent electrode (4a) and the bus electrode (4b) on the substrate (2) includes:

forming the bus electrode (4b) having the inclination angle of 30° to 70° on the substrate (2);  
forming the transparent electrode (4a) so as to contact with the bus electrode (4b) on the substrate (2) having the bus electrode (4b); wherein the bus electrode (4b) is formed by patterning a metal deposited on the substrate using a photolithography process and an etching process using an etchant; and

**characterized in that** the etchant consists of phosphoric acid in a range of 55 to 60 weight %, nitric acid in a range of 10 to 12 weight %, acetic acid in a range of 8 to 10 weight %, and water in a range of 18 to 27 weight %.

3. The method according to claim 1 or 2, wherein the etchant has a temperature of 30°C to 35°C.

4. The method according to claim 1 or 2, wherein the metal includes at least one of chrome, molybdenum, and copper.

## Patentansprüche

5

1. Verfahren zur Herstellung einer organischen Elektrolumineszenz-Anzeigevorrichtung, aufweisend:

Bilden einer Anodenelektrode (4), welche eine transparente Elektrode (4a) und eine Buselektrode (4b) umfasst, auf einem Substrat (2);

10 Bilden einer organischen Schicht (10), welche Licht auf dem Substrat (2), welches die Anodenelektrode (4) aufweist, erzeugt; und

Bilden einer Kathodenelektrode (12), welche die Anodenelektrode auf dem Substrat (2) mit der organischen Schicht (10) kreuzt, wobei die Buselektrode (4b) einen Neigungswinkel von 30° bis 70° zum Substrat (2) aufweist, und

15

wobei das Bilden der Anodenelektrode (4) auf dem Substrat, welche die transparente Elektrode (4a) und die Buselektrode (4b) aufweist, umfasst:

Bilden der transparenten Elektrode (4a) auf dem Substrat (2);

20 Bilden der Buselektrode (4b) mit dem Neigungswinkel von 30° bis 70° auf der transparenten Elektrode (4a);

wobei die Buselektrode (4b) gebildet wird durch Formen eines Metalls, das auf dem Substrat unter Verwendung eines Photolithographieverfahrens und eines Ätzverfahrens unter Verwendung eines Ätzmittels abgeschieden wird; und

25

**dadurch gekennzeichnet,**

**dass** das Ätzmittel in einer Größenordnung von 55 bis 60 Gewichtsprozent aus Phosphorsäure, in einer Größenordnung von 10 bis 12 Gewichtsprozent aus Salpetersäure, in einer Größenordnung von 8 bis 10 Gewichtsprozent aus Essigsäure und in einer Größenordnung von 18 bis 27 Gewichtsprozent aus Wasser besteht.

- 30 2. Verfahren zur Herstellung einer organischen Elektrolumineszenz-Anzeigevorrichtung, aufweisend:

Bilden einer Anodenelektrode (4), welche eine transparente Elektrode (4a) und eine Buselektrode (4b) umfasst, auf einem Substrat (2);

35 Bilden einer organischen Schicht (10), welche Licht auf dem Substrat (2), welches die Anodenelektrode (4) aufweist, erzeugt; und

Bilden einer Kathodenelektrode (12), welche die Anodenelektrode auf dem Substrat (2) mit der organischen Schicht (10) kreuzt, wobei die Buselektrode (4b) einen Neigungswinkel von 30° bis 70° zum Substrat (2) aufweist, und

40

wobei das Bilden der Anodenelektrode (4) auf dem Substrat, welche die transparente Elektrode (4a) und die Buselektrode (4b) aufweist, umfasst:

Bilden der Buselektrode (4b) mit dem Neigungswinkel von 30° bis 70° auf dem Substrat (2);

45 Bilden der transparenten Elektrode (4a) derart, dass sie die Buselektrode (4b) auf dem Substrat (2), welches die Buselektrode (4b) aufweist, kontaktiert,

wobei die Buselektrode (4b) gebildet wird durch Formen eines Metalls, das auf dem Substrat unter Verwendung eines Photolithographieverfahrens und eines Ätzverfahrens unter Verwendung eines Ätzmittels abgeschieden wird; und

50

**dadurch gekennzeichnet,**

**dass** das Ätzmittel in einer Größenordnung von 55 bis 60 Gewichtsprozent aus Phosphorsäure, in einer Größenordnung von 10 bis 12 Gewichtsprozent aus Salpetersäure, in einer Größenordnung von 8 bis 10 Gewichtsprozent aus Essigsäure und in einer Größenordnung von 18 bis 27 Gewichtsprozent aus Wasser besteht.

- 55 3. Verfahren nach Anspruch 1 oder 2, wobei das Ätzmittel eine Temperatur von 30° bis 35°C hat.

4. Verfahren nach Anspruch 1 oder 2, wobei das Metall mindestens eines von Chrom, Molybdän und Kupfer aufweist.

Revendications

1. Procédé de fabrication d'un dispositif d'affichage par électroluminescence organique, comportant les étapes consistant à :

5

former une électrode (4) d'anode comprenant une électrode transparente (4a) et une électrode (4b) de bus sur un substrat (2) ;

10

former une couche organique (10) générant de la lumière sur le substrat (2) doté de l'électrode (4) d'anode ; et former une électrode (12) de cathode croisant l'électrode d'anode sur le substrat (2) doté de la couche organique (10),

l'électrode (4b) de bus présentant un angle d'inclinaison de 30° à 70° par rapport au substrat (2), et la formation de l'électrode (4) d'anode dotée de l'électrode transparente (4a) et de l'électrode (4b) de bus sur le substrat comportant les étapes consistant à :

15

former l'électrode transparente (4a) sur le substrat (2) ;

former l'électrode (4b) de bus présentant l'angle d'inclinaison de 30° à 70° sur l'électrode transparente (4a) ;

20

l'électrode (4b) de bus étant formée par un motif de métal déposé sur le substrat par un processus de photolithographie et un processus d'attaque chimique utilisant un agent d'attaque chimique ; et

**caractérisé en ce que** l'agent d'attaque chimique est constitué d'acide phosphorique dans une plage de 55 à 60 % en poids, d'acide nitrique dans une plage de 10 à 12 % en poids, d'acide acétique dans une plage de 8 à 10 % en poids et d'eau dans une plage de 18 à 27 % en poids.

25

2. Procédé de fabrication d'un dispositif d'affichage par électroluminescence organique, comportant les étapes consistant à :

30

former une électrode (4) d'anode comprenant une électrode transparente (4a) et une électrode (4b) de bus sur un substrat (2) ;

former une couche organique (10) générant de la lumière sur le substrat (2) doté de l'électrode (4) d'anode ; et former une électrode (12) de cathode croisant l'électrode d'anode sur le substrat (2) doté de la couche organique (10),

35

l'électrode (4b) de bus présentant un angle d'inclinaison de 30° à 70° par rapport au substrat (2), et la formation de l'électrode (4) d'anode dotée de l'électrode transparente (4a) et de l'électrode (4b) de bus sur le substrat (2) comportant les étapes consistant à :

40

former l'électrode (4b) de bus présentant l'angle d'inclinaison de 30° à 70° sur le substrat (2) ;

former l'électrode transparente (4a) de telle façon qu'elle soit en contact avec l'électrode (4b) de bus sur le substrat (2) doté de l'électrode (4b) de bus ;

l'électrode (4b) de bus étant formée par un motif de métal déposé sur le substrat par un processus de photolithographie et un processus d'attaque chimique utilisant un agent d'attaque chimique ; et

45

**caractérisé en ce que** l'agent d'attaque chimique est constitué d'acide phosphorique dans une plage de 55 à 60 % en poids, d'acide nitrique dans une plage de 10 à 12 % en poids, d'acide acétique dans une plage de 8 à 10 % en poids et d'eau dans une plage de 18 à 27 % en poids.

3. Procédé selon la revendication 1 ou 2, l'agent d'attaque chimique se trouvant à une température de 30°C à 35°C.

50

4. Procédé selon la revendication 1 ou 2, le métal comprenant au moins un élément parmi le chrome, le molybdène et le cuivre.

55

FIG. 1  
RELATED ART

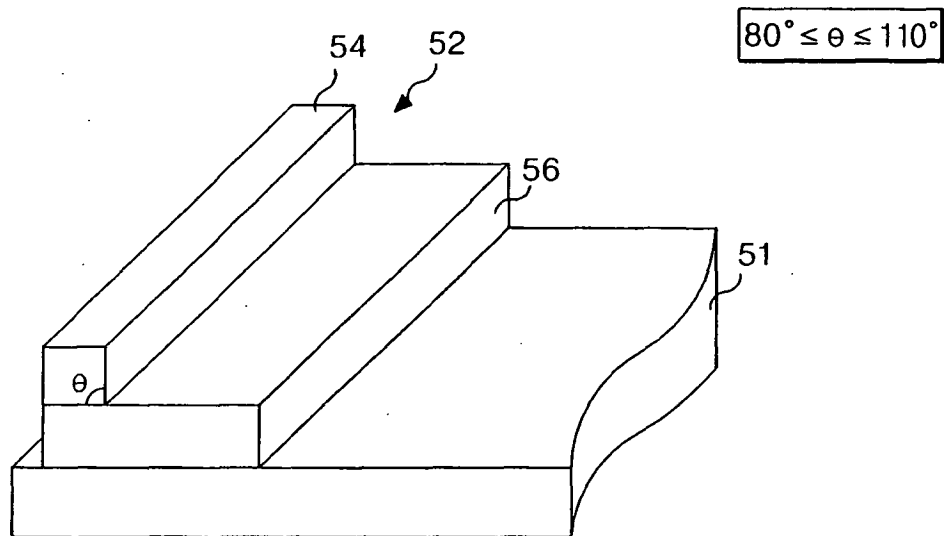

FIG. 2  
RELATED ART

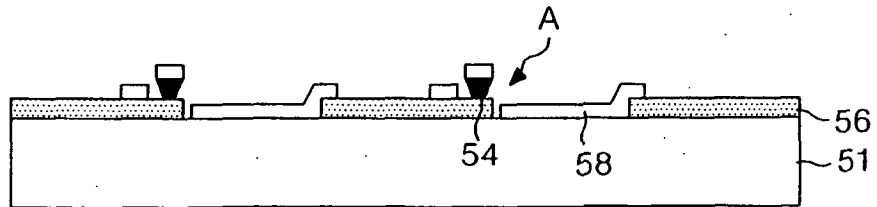

FIG.3

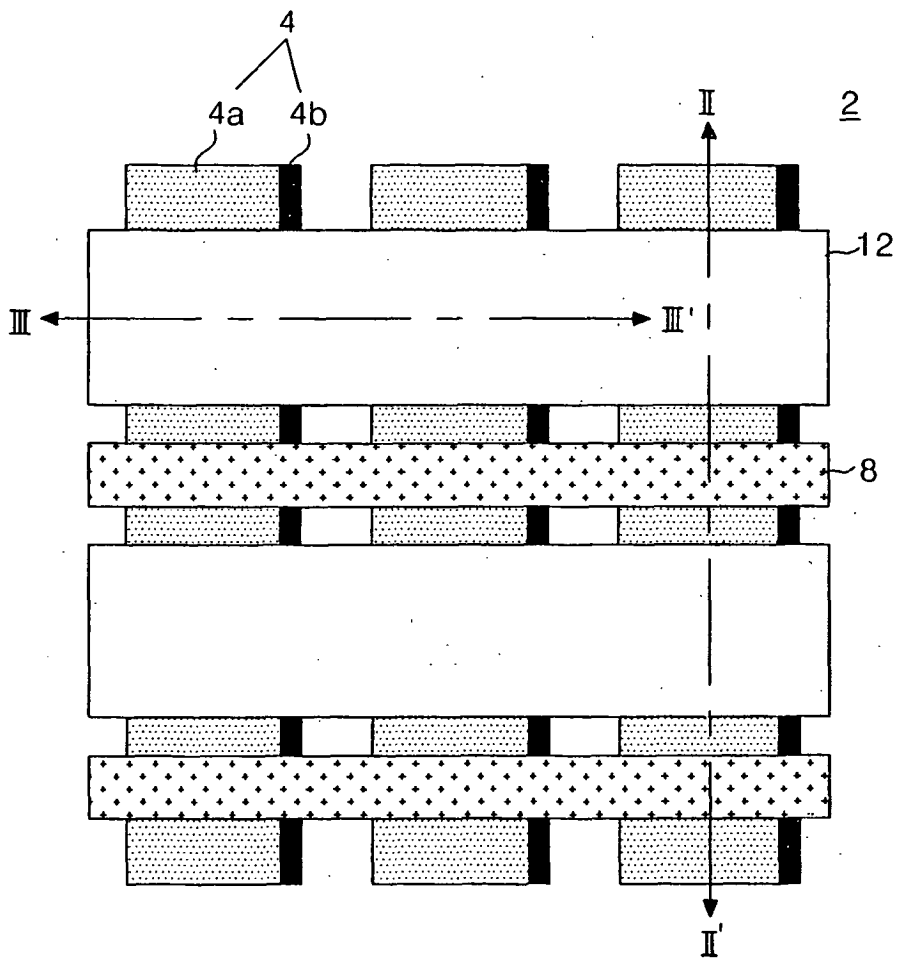

FIG. 4

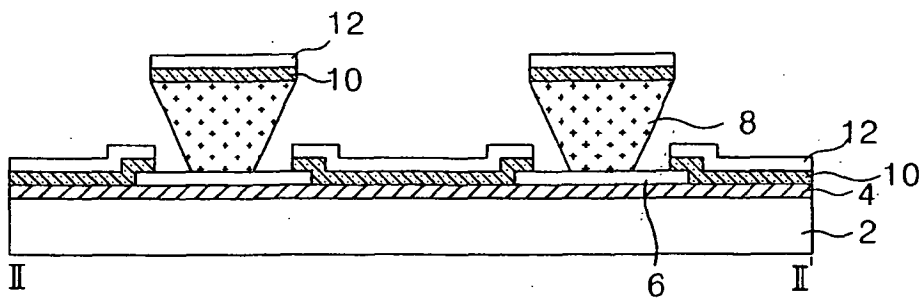

FIG. 5

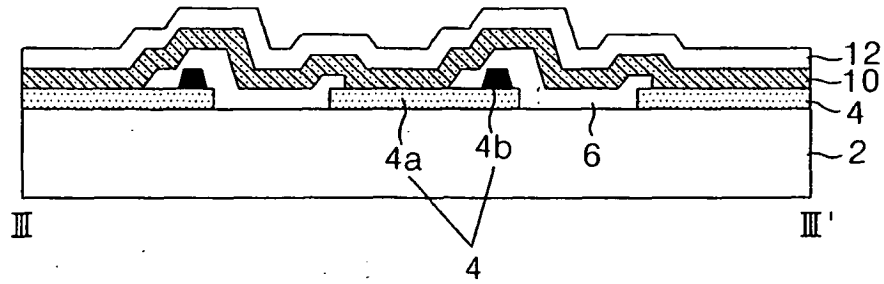

FIG. 6A

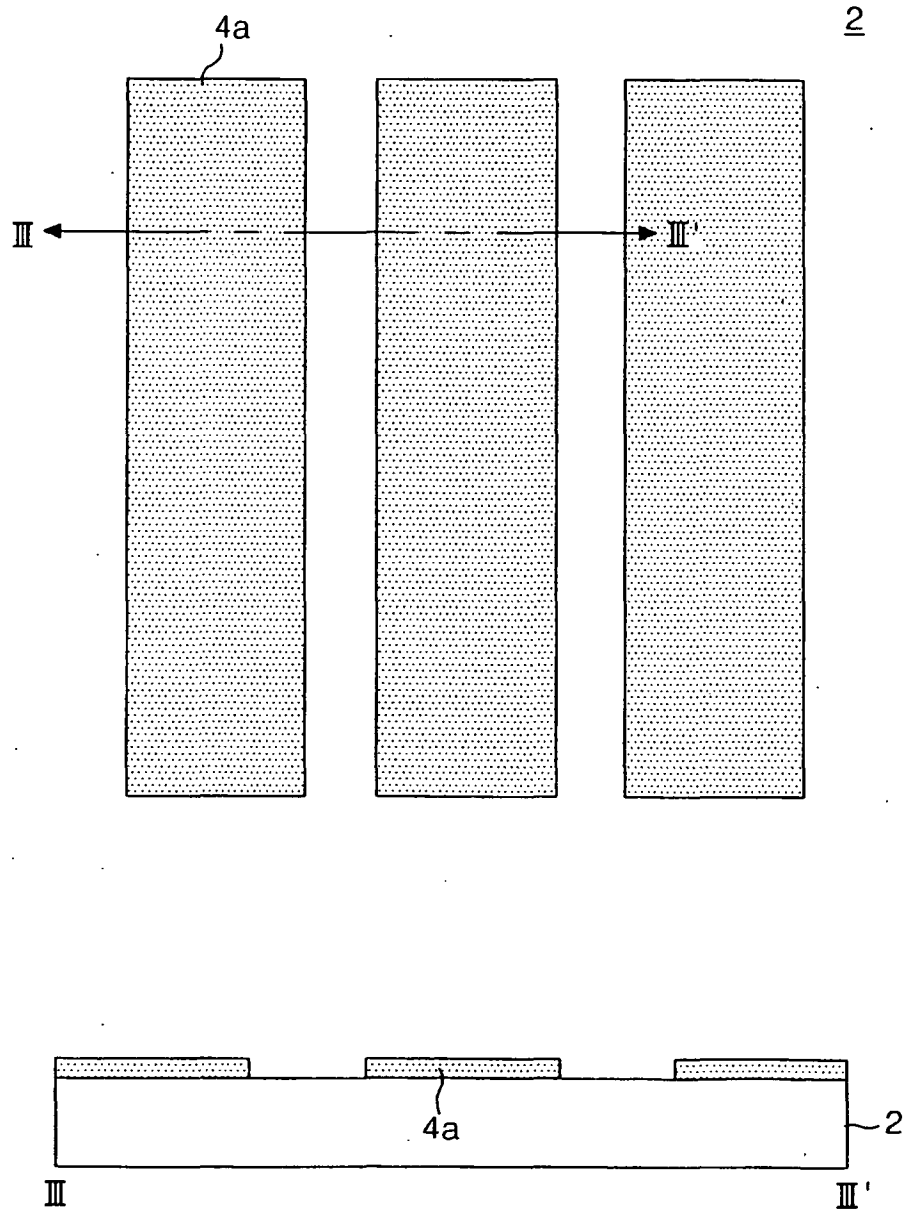

FIG. 6B

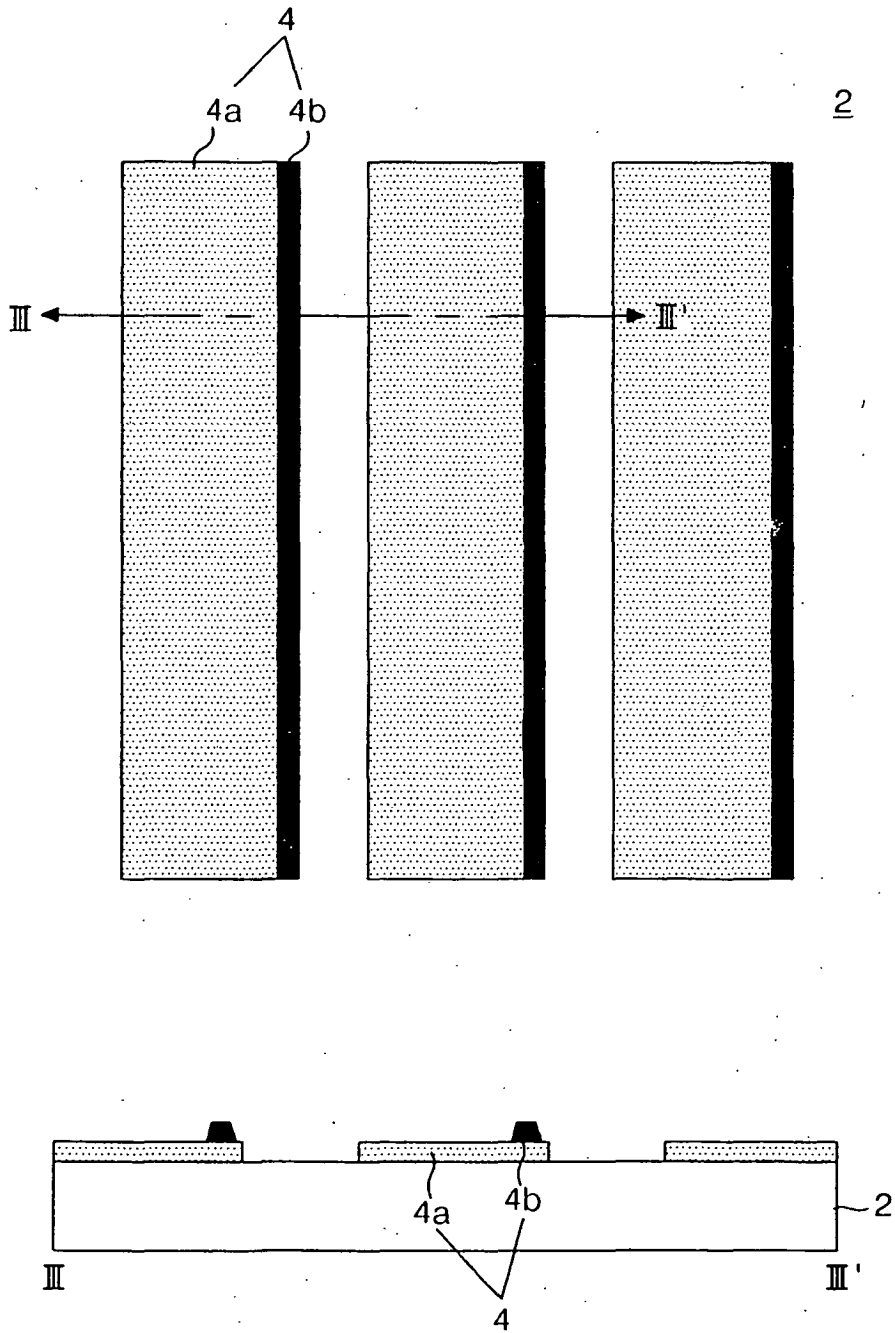

FIG. 6C

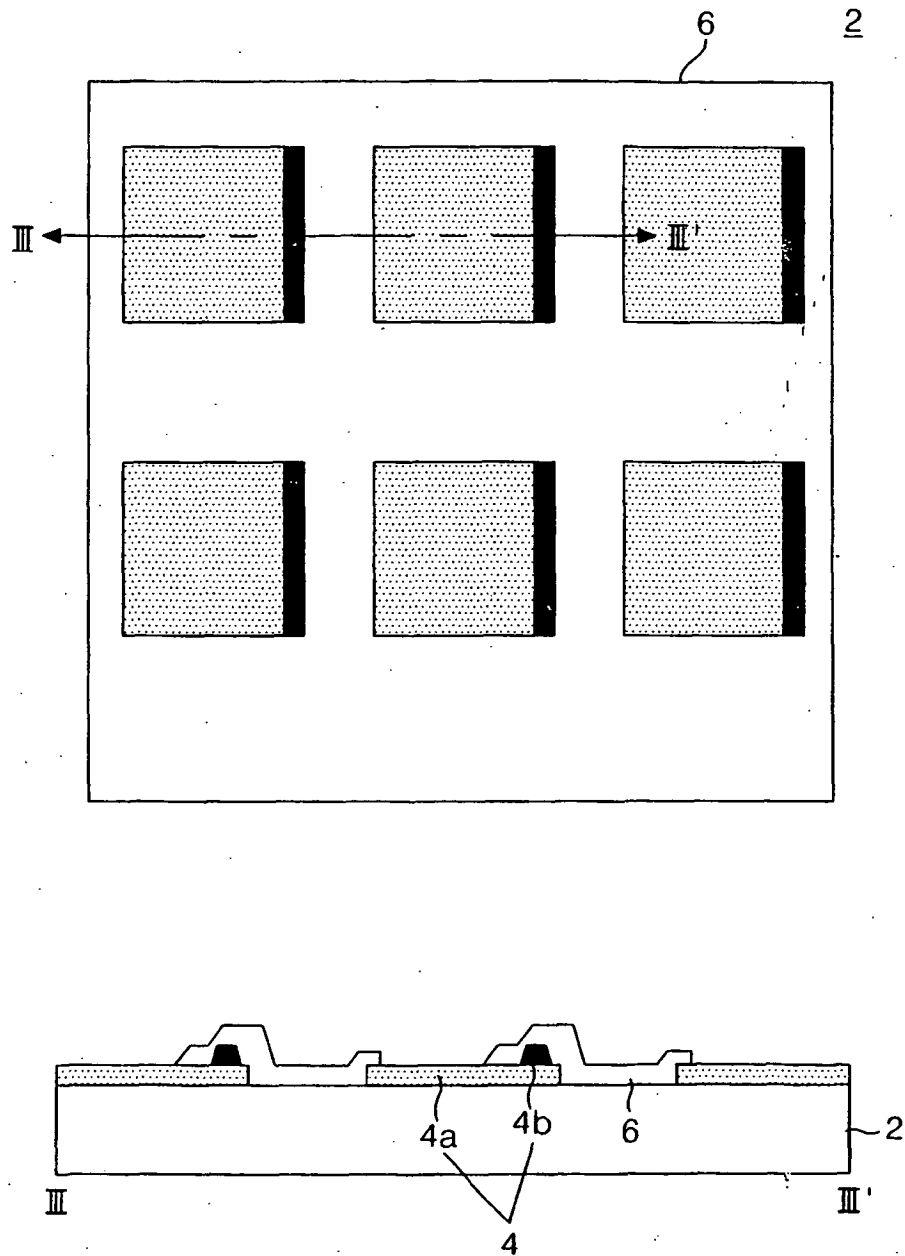

FIG. 6D

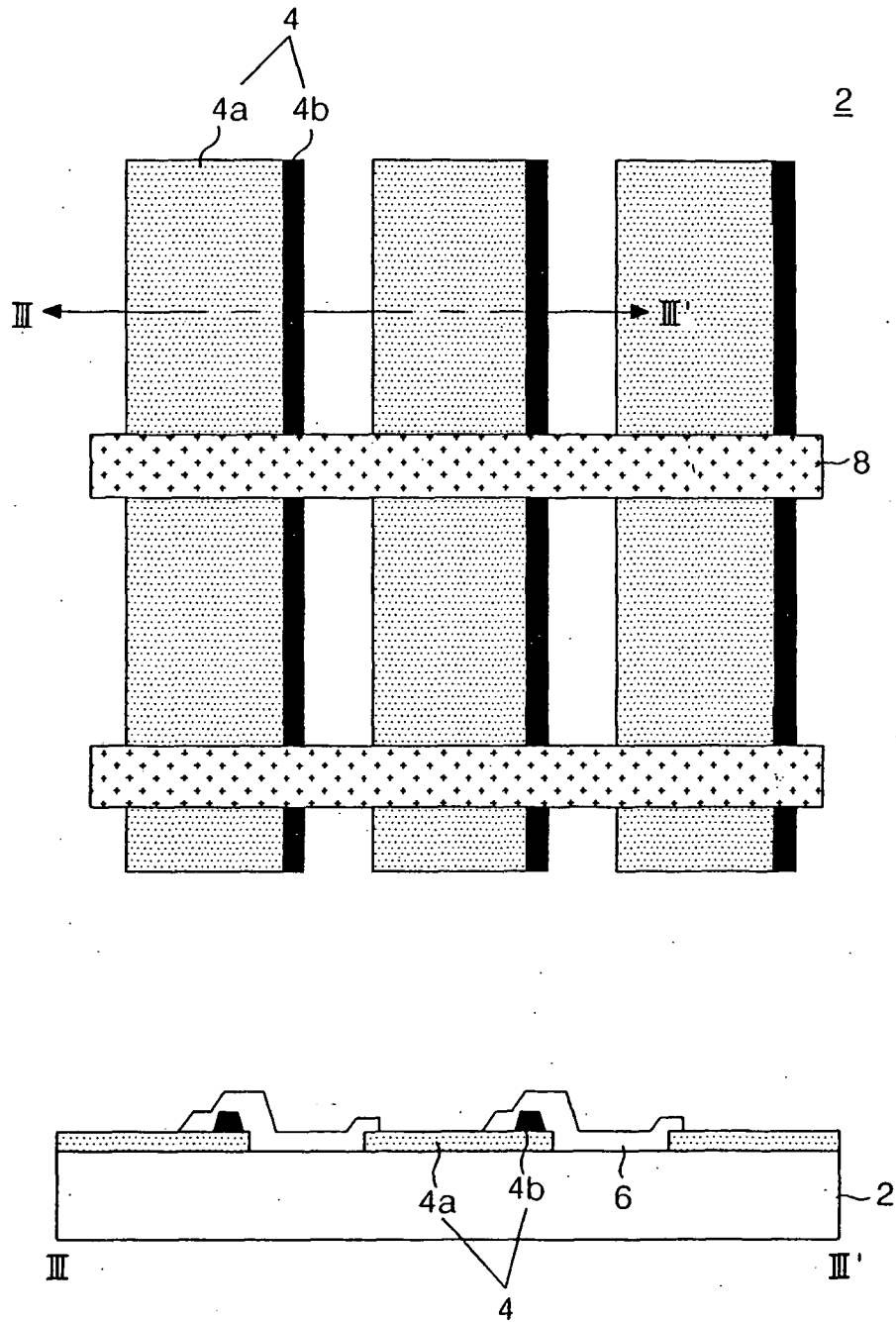

FIG. 6E

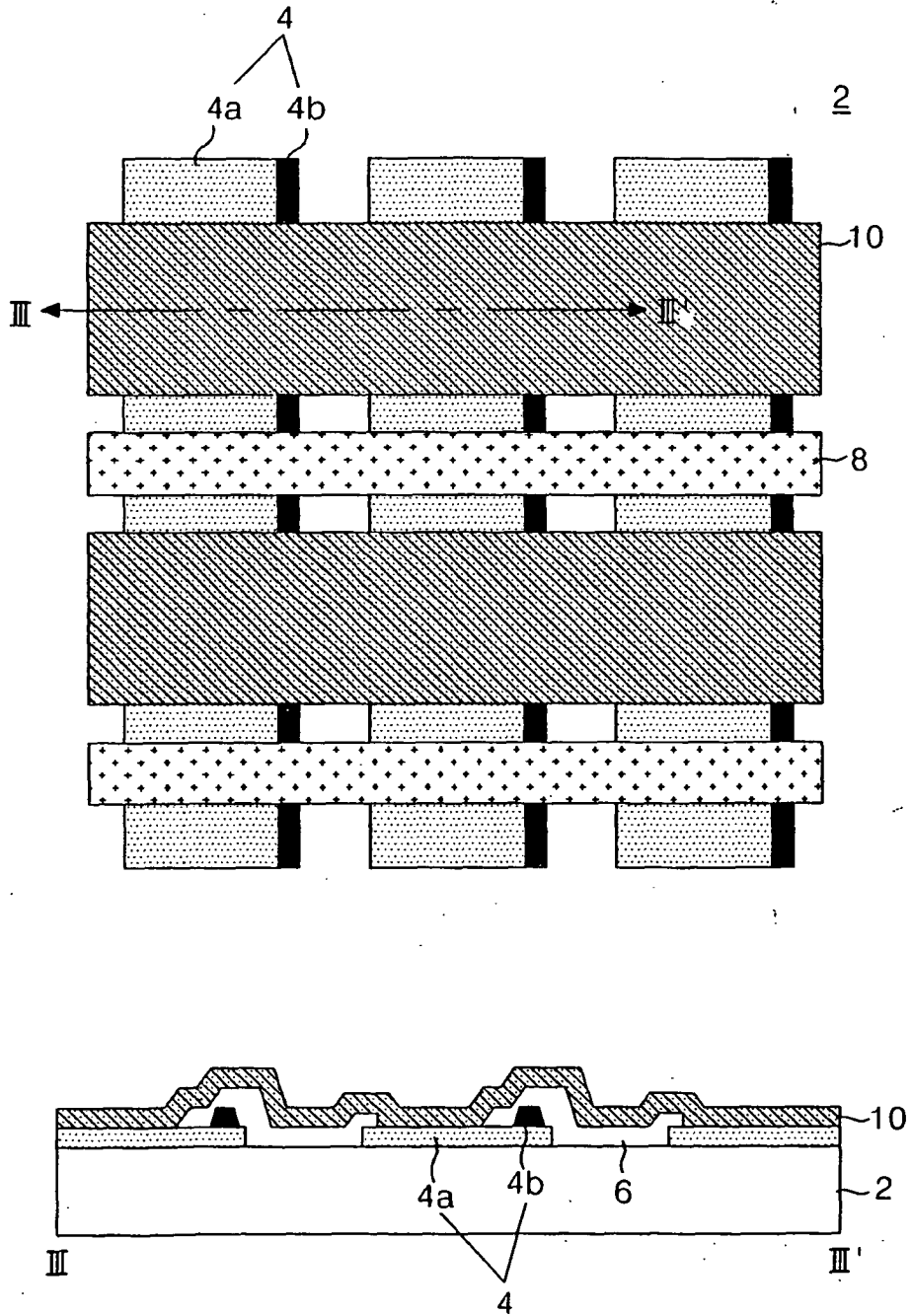

FIG. 6F

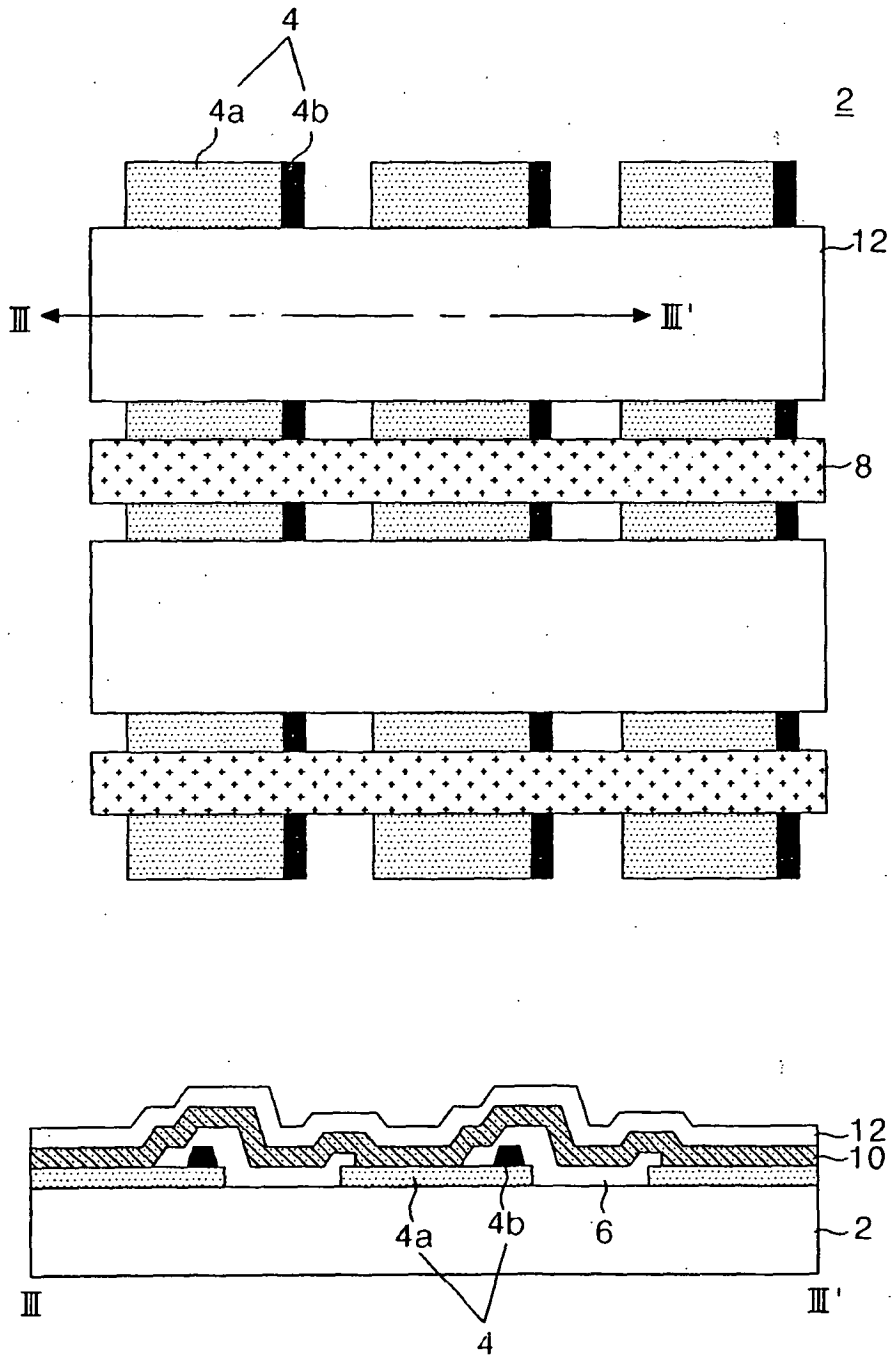

FIG. 7A

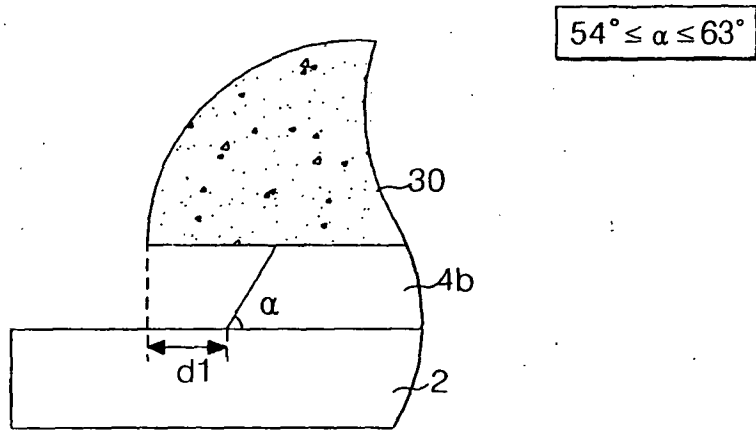
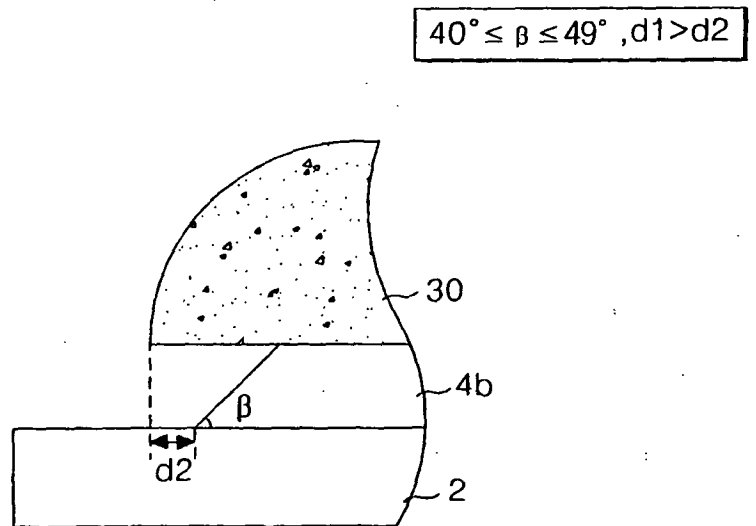

FIG. 7B



**REFERENCES CITED IN THE DESCRIPTION**

*This list of references cited by the applicant is for the reader's convenience only. It does not form part of the European patent document. Even though great care has been taken in compiling the references, errors or omissions cannot be excluded and the EPO disclaims all liability in this regard.*

**Patent documents cited in the description**

- KR P200419684 [0001]
- EP 0888035 A1 [0002]

**Non-patent literature cited in the description**

- *PATENT ABSTRACTS OF JAPAN*, 10-106751 [0002]

专利名称(译)	有机电致发光显示装置及其制造方法		
公开(公告)号	<a href="#">EP1580824B1</a>	公开(公告)日	2008-05-14
申请号	EP2005005803	申请日	2005-03-17
申请(专利权)人(译)	LG电子株式会社.		
当前申请(专利权)人(译)	LG电子株式会社.		
[标]发明人	JUNG YOUNG RO JU JAE HYOUNG		
发明人	JUNG, YOUNG RO JU, JAE HYOUNG		
IPC分类号	H01L51/52 H01L51/56 H05B33/26 H01L27/32 H01L51/50 H05B33/10		
CPC分类号	H01L51/5212 H01L27/3281		
代理机构(译)	鲁普雷希特, KAY		
优先权	1020040019684 2004-03-23 KR		
其他公开文献	EP1580824A1		
外部链接	<a href="#">Espacenet</a>		

摘要(译)

有机电致发光器件及其制造方法本发明涉及一种能够减小母线电极的倒锥形的有机电致发光器件及其制造方法。一种有机电致发光显示装置，包括：阳极，包括透明电极和汇流电极；阴极电极与阳极电极交叉；和位于阳极和阴极交叉处的有机层，其中汇流电极具有30°至70°的倾斜角。

FIG. 1  
RELATED ART

