



Europäisches Patentamt  
 European Patent Office  
 Office européen des brevets



(11) **EP 1 091 340 A2**

(12) **EUROPEAN PATENT APPLICATION**

(43) Date of publication:  
**11.04.2001 Bulletin 2001/15**

(51) Int. Cl.<sup>7</sup>: **G09G 3/32**

(21) Application number: **00121697.7**

(22) Date of filing: **04.10.2000**

(84) Designated Contracting States:  
**AT BE CH CY DE DK ES FI FR GB GR IE IT LI LU  
 MC NL PT SE**  
 Designated Extension States:  
**AL LT LV MK RO SI**

(72) Inventors:  
 • **Iketsu, Yuichi**  
 Tokyo (JP)  
 • **Sakaguchi, Yoshikazu**  
 Tokyo (JP)

(30) Priority: **05.10.1999 JP 28416799**

(74) Representative:  
**Glawe, Delfs, Moll & Partner**  
 Patentanwälte  
 Postfach 26 01 62  
 80058 München (DE)

(71) Applicant: **NEC CORPORATION**  
 Tokyo (JP)

(54) **Driving device and driving method of organic thin film EL display**

(57) A comparator (compares the signal voltage  $S(i, j)$  applied to the display element  $P(i, j)$  on a predetermined data electrode ( $X_i$ ) on the scanning electrode ( $Y_j$ ) for the current display period and the signal voltage  $S(i, j+1)$  applied to the display element  $P(i, j+1)$  on the data electrode ( $X_i$ ) on the scanning electrode  $Y(j+1)$  during the next display period. A controller controls a discharge of residual electric charges or a quantity of residual electric charges discharged from the data electrode ( $X_i$ ) during a blanking period immediately before the next display period depending on the comparison result by the comparator.

**FIG. 2**

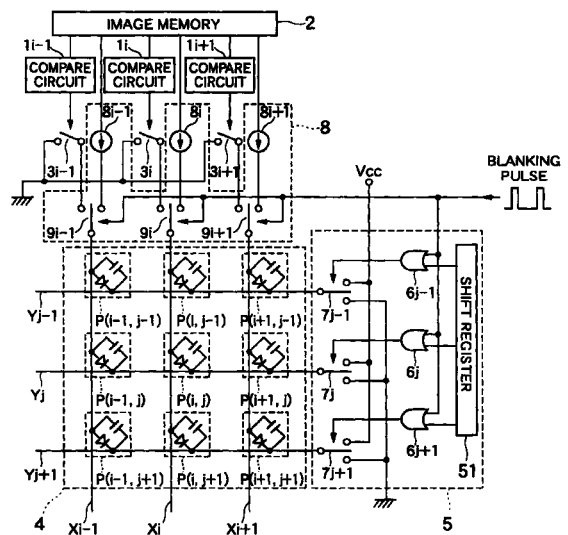

**EP 1 091 340 A2**

**Description**

## FIELD OF THE INVENTION

**[0001]** The present invention relates to a driving device and a driving method of an organic thin film electroluminescent (EL) display. In particular, the present invention relates to a driving device and a driving method of an organic thin film EL display with reduced power consumption.

## DESCRIPTION OF THE RELATED ART

**[0002]** An example of conventional methods for driving an organic thin film EL display is described in Japanese Patent Laid-Open Publication No. Hei 9-232074. Fig. 1 is a circuit diagram of the prior art showing an example of a conventional configuration where data electrodes  $X_i$  and scanning electrodes  $Y_j$  arrayed in a matrix are passively driven. A blanking period is provided between display periods. All the switching circuits  $9_i$ ,  $7_j$  are switched to the ground side in response to a blanking pulse transmitted during this period. As a result, residual electric charges accumulated in all the data lines are discharged. In Fig. 1, reference numeral 2 is an image memory, reference numeral 8 is a driving circuit, reference numeral 4 is an organic thin film EL display, reference numeral 5 is a scanning circuit, reference numeral 51 is a sift register, and reference numeral 6j is an OR circuit.

**[0003]** A pixel  $P(i, j)$  is taken for example here. If a scanning electrode  $Y_j$  to which this pixel  $P(i, j)$  belongs is selected, that is, the pixel  $P(i, j)$  is in a turned-off state during a display period  $T_j$ , a reverse bias is applied to the parallel capacitors of all the pixels  $P(i, 1)$  to  $P(i, j-1)$  and  $P(i, j+1)$  to  $P(i, n)$  belonging to a data electrode  $X_i$  except for the pixel  $P(i, j)$ . If a shift is made to the next display period  $T(j+1)$  in this state and a pixel  $P(i, j+1)$  is turned on, current from a current source circuit  $8_i$  connected to the data electrode  $X_i$  is first used to cancel charge of the aforementioned reverse-biased parallel capacitors. Consequently, a long delay develops before the pixel  $P(i, j+1)$  actually starts emitting light, and thereby a large-capacitance display is not enabled. Thus, a certain effect can be made by providing a blanking period  $t_j$  between the display period  $T_j$  and the display period  $T(j+1)$  and applying the data electrode  $X_i$  to the ground potential during this blanking period to cancel the charge of the reverse-biased parallel capacitor of the pixel  $P(i, 1)$  to  $P(i, j-1)$  and  $P(i, j+1)$  to  $P(i, n)$ .

**[0004]** However, if the pixel  $P(i, j)$  is in a turned-on state during the display period  $T_j$ , all the pixels  $P(i, 1)$  to  $P(i, j-1)$  and  $P(i, j+1)$  to  $P(i, n)$  belonging to the data electrode  $X_i$  except for the pixel  $P(i, j)$  are almost zero-biased. Since the parallel capacitor of the pixel  $P(i, j)$  is forward-biased, applying the data electrode  $X_i$  to the ground potential during the blanking period  $t_j$  is not only almost useless, but also electric charges in the forward-

biased parallel capacitor of the pixel  $P(i, j)$  are wasted.

**[0005]** An object of the present invention is to provide a driving device and a driving method of an organic thin film EL display with power consumption reduced by a configuration where electric charges accumulated in a display element are used to assist a display element to emit light during the next display period.

**[0006]** A driving device of an organic thin film EL display according to a first aspect of the present invention, display elements composed of organic thin film EL light-emitting elements are connected to respective intersections of data electrodes and scanning electrodes arrayed in a matrix. While the scanning electrode is scanned at predetermined periods, the display element emits light in response to a signal applied to the data electrode in synchronization with the scanning. The driving apparatus has a comparator comparing a signal voltage applied to a display element on a predetermined data electrode and on a scanning electrode for the current display period and a signal voltage applied to the display element on the data electrode and on the scanning electrode for the next display period. The driving device also has a controller controlling a discharge of residual electric charges from the data electrode on the currently displaying scanning electrode during a blanking period immediately before the next display period depending on the comparison result by the comparator.

**[0007]** In a driving device of an organic thin film EL display according to the second aspect of the present invention, display elements composed of organic thin film EL light-emitting elements are connected to respective intersections of data electrodes and scanning electrodes arrayed in a matrix. While the scanning electrode is scanned at predetermined periods, the display element emits light in response to a signal applied to the data electrode in synchronization with the scanning. The driving device has a comparator comparing a signal voltage of the display element on a predetermined data electrode and on the scanning electrode for the current display period and a signal voltage of the display element on this data electrode and on the scanning electrode for the next display period. The driving device also has a controller controlling a quantity of residual electric charges discharged from the data electrode on the currently displaying scanning electrode during a blanking period immediately before the next display period depending on the comparison result by the comparator.

**[0008]** If an image signal voltage  $S(i, j)$  for the current display period is larger than an image signal voltage  $S(i, j+1)$  for the next display period, the controller controls the data electrode on the currently displaying scanning electrode so that residual electric charges are discharged during the blanking period immediately before the next display period. If an image signal voltage  $S(i, j)$  for the current display period is equal to or less than an image signal voltage  $S(i, j+1)$  for the next display period, the controller controls the data electrode

so that the residual electric charges are not discharged.

**[0009]** Further, the controller also controls a discharge circuit which holds the data electrode at the ground level, for example.

**[0010]** Also provided is an image memory having a memory capacity at least enough for  $2 \times m$  ( $m$ : the number of data electrodes). The signal voltage applied to each data electrode on the currently displaying scanning electrode for a display period and the signal voltage applied to the data electrode on the scanning electrode for the next display period are stored in this image memory so that the comparator can compare the data in the image memory.

**[0011]** The driving device of an organic film EL display also has the same number of discharge circuits as, for example, the number of data electrodes ( $m$ ).

**[0012]** In the driving method of an organic thin film EL display according to the present invention, display elements composed of organic thin film EL light-emitting elements are connected to respective intersections of data electrodes and scanning electrodes arrayed in a matrix. While the scanning electrode is scanned at predetermined periods, the display element emits light in response to a signal applied to the data electrode in synchronization with the scanning. The driving method has steps of comparing a signal voltage applied to the display element on a predetermined data electrode on the scanning electrode for the current display period and a signal voltage applied to the display element on this data electrode and on the scanning electrode for the next display period; and controlling the data electrode so as to be in the discharge state during the blanking period immediately before the display period when the signal voltage applied to the display element on the predetermined data electrode on the scanning electrode for the current display period is larger than the signal voltage applied to the display element on the data electrode for the next display period or controlling the data electrode so as not to be in the discharge state otherwise.

**[0013]** According to the driving device and the driving method of an organic thin film EL display of the present invention, residual electric charges which are conventionally discharged uniformly from all the data electrodes during the blanking period are discharged individually from each data electrode. That is, since residual electric charges do not need to be discharged from a data electrode during the blanking period if the signal voltage for the current display period is not larger than the signal voltage for the next display period, a wasted outflow of electric charges can be prevented by detecting such an electrode. Thus, the first effect of the present invention is electric power saving. It is particularly effective to a display pattern such that all of display elements (pixels) are turned on or the like, where signal voltage applied to each data electrode does not decrease.

**[0014]** According to the present invention, the sec-

ond effect of the present invention is the improvement of responsiveness when a pixel emits light and the improvement of brightness since residual electric charges which are not discharged during the blanking period are contributed to the charge of the parallel capacitor of a pixel which should emit light during the next display period.

**[0015]** The nature, principle, and utility of the invention will become more apparent from the following detailed description when read in conjunction with the accompanying drawings in which like parts are designated by like reference numerals or characters. In the accompanying drawings:

Fig. 1 is a circuit diagram of the prior art;

Fig. 2 is a circuit diagram showing a driving device of an organic thin film EL display according to a first embodiment of the present invention;

Fig. 3 is a timing chart illustrating a specific operation of the first embodiment of the present invention;

Fig. 4 is a circuit diagram illustrating a current flow and a state that electric charges are accumulated during a display period  $T_j$  in the first embodiment of the present invention;

Fig. 5 is a circuit diagram illustrating a state that electric charges are discharged during a blanking period  $t_j$  when  $S(i, j) > S(i, j+1)$ ;

Fig. 6 is a circuit diagram illustrating a current flow and a state that electric charges are transferred during a display period  $T_{(j+1)}$  when  $S(i, j) \leq S(i, j+1)$ ;

Fig. 7 is a circuit diagram showing a driving device of an organic thin film EL display according to a second embodiment of the present invention; and

Fig. 8 is a perspective view showing a structure of an organic thin film EL display.

**[0016]** Embodiments of the driving device and driving method of an organic thin film EL display according to the present invention will be described in detail below with reference to accompanying drawings.

**[0017]** The driving device of an organic thin film EL display according to the present invention is characterized in that, when data electrodes and scanning electrodes arrayed in a matrix are passively driven, residual electric charges which are uniformly discharged from all the data electrodes in a conventional manner during a blanking period are discharged individually from each data electrode.

**[0018]** As shown in Fig. 2, a compare circuit 1i provided for a data electrode  $X_i$  ( $i = 1$  to  $m$ :  $m$  is the number of data electrodes) reads the image signal voltage  $S(i, j)$  ( $j = 1$  to  $n$ :  $n$  is the number of the scanning electrodes) for the current display period and the image signal voltage  $S(i, j+1)$  for the next display period from an image memory 2 to compare them. During a blanking period immediately before the next display period,

the discharge circuit 3i controls the quantity of residual electric charges discharged from the data electrode Xi depending on this comparison result. That is, the data electrode Xi is controlled depending on the comparison result so that residual electric charges are discharged or not.

**[0019]** Figs. 2 to 6 show the driving device of organic thin film EL display according to the first embodiment of the present invention. Fig. 3 is a timing chart of the first embodiment illustrating an operation of the first embodiment of the present invention. Fig. 4 is a circuit diagram illustrating a current flow and a state that electric charges are accumulated during a display period Tj in the first embodiment of the present invention. Fig. 5 is a circuit diagram illustrating a state that electric charges are discharged during a blanking period tj when  $S(i, j) > S(i, j+1)$ . Fig. 6 is a circuit diagram illustrating a current flow and a state that electric charges are transferred during a display period T(j+1) when  $S(i, j) \leq S(i, j+1)$ .

**[0020]** These figures show a driving device of an organic thin film EL display constituted such that display elements P(i, j) composed of organic thin film EL light-emitting elements are connected to respective intersections of data electrodes Xi (i = 1 to m) and scanning electrodes Yj (j = 1 to n) arrayed in a matrix. While a scanning electrode is scanned at predetermined periods, the display element emits light in response to a signal applied to the data electrode in synchronization with the scanning.

**[0021]** The driving device has comparator 1i for comparing the signal voltage S(i, j) applied to a display element P(i, j) on a predetermined data electrode Xi on a scanning electrode Yj for the current display period and the signal voltage S(i, j+1) applied to the display element P(i, j+1) on this data electrode Xi and on the scanning electrode Y(j+1) for the next display period.

**[0022]** The driving apparatus also has controller 3i for controlling a quantity of residual electric charges discharged from the data electrode on the currently displaying scanning electrode Yj during a blanking period immediately before the next display period depending on the comparison result by the comparator.

**[0023]** In a first case ( $S(i, j) > S(i, j+1)$ ), the controller 3i controls the data electrode Xi on the currently displaying scanning electrode Yj so that residual electric charges are discharged during the blanking period immediately before the next display period. In a second case ( $S(i, j) \leq S(i, j+1)$ ), the controller 31 controls the data electrode Xi so that the residual electric charges are not discharged.

**[0024]** The controller 3i controls a discharge circuit which holds the data electrode in the ground level.

**[0025]** An image memory 2 having a memory capacity at least enough for  $2 \times m$  (m: the number of data electrodes) is also provided. The signal voltage S(1, j) to S(m, j) applied to each data electrode X1 to Xm on scanning electrode Yj for the current display period and the signal voltage S(1, j+1) to S(m, j+1) applied to

each data electrode X1 to Xm on the scanning electrode Y(j+1) for the next display period are stored in this image memory 2 so that the comparator 11 to 1m can compare the data in the image memory 2.

**[0026]** The driving apparatus for driving an organic thin film EL display is also characterized by having the same number of discharge circuits as the number of data electrodes (m).

**[0027]** The first embodiment will be described in further detail below. Fig. 8 is a perspective view showing a structure of an organic thin film EL display.

**[0028]** Fig. 8 shows a common structure of an organic thin film EL display 4 driven by the present invention. In Fig. 8, an organic thin film EL display 4 is composed of a number (m) of data electrodes Xi (i = 1 - m) and a number (n) of scanning electrodes Yj (j = 1 - n) formed orthogonally to each other on a substrate 41 and an organic thin film layer 42 interposed between these electrodes. As a substrate 41, light-transmittable glass, resin or the like is used. As a data electrode Xi, light-transmittable ITO, NESA film, metal thin film or the like is used. As a scanning electrode Yj, Ag/Mg alloy, Al/Li alloy or the like is used. The organic thin film layer 42 is constituted by a plurality of organic laminated layer film composed of a hole implantation layer, hole transport layer, light-emitting layer, electron transport layer, electron implantation layer and so forth or a single layer film composed of only a light-emitting layer and is formed by a thin film forming technique such as a vacuum deposition method, spin-coating method, casting method or the like. In the above-described structure, when the data electrode Xi is charged as anode and the scanning electrode Yj is charged as cathode, the organic light-emitting layer of the region interposed between the data electrode Xi and the scanning electrode Yj emits light as a pixel P (i, j). In Fig. 2, a pixel P (i, j) is represented by a diode symbol and a capacitor connected in parallel with the diode. An image memory 2 is a memory circuit having a memory capacity at least enough for  $2 \times m$  (m: the number of pixels) and can be achieved by a field memory, FIFO, DRAM, SRAM or the like. A scan circuit 5 is composed of a shift register 51, an OR circuit 6j and a switching circuit 7j. A driving circuit 8 is constituted by a current source circuit 8i for supplying current to the data electrode Xi depending on the image signal voltage S(i, j) and a switching circuit 9i. A compare circuit 1i compares the image signal voltage S(i, j) for the current display period and the image signal voltage S(i, j+1) for the next display period read from the image memory 2 and controls the discharge circuit 3i during a blanking period. The simplest form of a discharge circuit 3i is a switching circuit.

**[0029]** The operation of the first embodiment will be described below.

**[0030]** Fig. 3 is a timing chart showing an operation of each part of Fig. 2.

**[0031]** When a start pulse is applied to a shift register 51, a shift is made in synchronization with a clock

pulse. A switching circuit 7j is controlled by a shift pulse and a blanking pulse so that the scanning electrode Yj is connected to the ground side when the control input is at a high level and connected to the power supply voltage VCC side when the control input is at a low level. On the other hand, the switching circuit 9i is controlled only by a blanking pulse so that the data electrode Xi is connected to the discharge circuit 3i when the control input is at a high level and connected to the current source circuit 8i when the control input is at a low level. Therefore, during a display period Tj, current is supplied from the current source circuit 8i to the data electrode Xi depending on the image signal voltage S(i, j). As shown in Fig. 4, if  $S(i, j) > 0$ , the charge current flows in the order of the current source circuit 8i, the switching circuit 9i, the pixel P(i, j), the switching circuit 7j and the ground (GND). Then, the pixel P(i, j) emits light and electric charges are accumulated in the parallel capacitor. During this period, the image signal voltage S(i, j) for the current display period and the image signal voltage S(i, j+1) for the next display period are compared in the compare circuit 1i.

**[0032]** During a blanking period tj, all the scanning electrodes Yj have a ground potential by a blanking pulse applied to the OR circuit 6j. At this time, the data electrode Xi is connected to the discharge circuit 3i side, but the discharge circuit 3i is controlled by the compare circuit 1i as follows depending on the comparison result of the displayed image signal voltage S(i, j) and the image signal voltage S(i, j+1) for the next scanning period.

**[0033]** As shown in Fig. 5, if  $S(i, j) > S(i, j+1)$ , the discharge circuit 3i composed of switching circuits is turned on and electric charges accumulated in the pixel P(i, j) are discharged. At this time, the discharge path is constituted in the order of the parallel capacitor of the pixel P(i, j), the switching circuit 9i, the discharge circuit 3i, the ground, the switching circuit 7j and the parallel capacitor of the pixel P(i, j).

**[0034]** On the contrary, as shown in Fig. 6, if  $S(i, j) \leq S(i, j+1)$ , the discharge circuit 3i is turned off, electric charges accumulated in the pixel P(i, j) are not discharged and the parallel capacitor of the pixel P(i, j+1) is charged during the next display period T(j+1). At this time, the charge path is constituted in the order of the power supply (VCC), the switching circuit 7j, the parallel capacitor of the pixel P(i, j), the parallel capacitor of the pixel P(i, j+1), the switching circuit 7(j+1) and the ground.

**[0035]** Fig. 7 is a circuit diagram showing a driving device and a driving method of an organic thin film EL display according to a second embodiment of the present invention.

**[0036]** Fig. 7 shows a driving device of an organic thin film EL display constituted such that display elements P(i, j) composed of organic thin film EL light-emitting elements are connected to respective intersections of data electrodes Xi and scanning electrodes Yj

arrayed in a matrix. While a scanning electrode is scanned at predetermined periods, the display element emits light in response to a signal applied to the data electrode in synchronization with the scanning.

**[0037]** The driving device has a comparator 1i (i = 1 to m) for comparing the signal voltage S(i, j) applied to the display element P(i, j) on a predetermined data electrode on the scanning electrode Yj for the current display period and the signal voltage S(i, j) applied to the display element on this data electrode and on the scanning electrode for the next display period.

**[0038]** The driving device also has a controller (discharge circuit 30i) for controlling a quantity of residual electric charges discharged from the data electrode on the currently displaying scanning electrode to a predetermined value during a blanking period immediately before the next display period depending on the comparison result by the comparator.

**[0039]** The second embodiment will be described in further detail below. The discharge circuit 30i has a resistance and the comparator circuit 1i controls the resistance value of the discharge circuit 30i.

**[0040]** In reference to Fig. 7, the discharge circuit 30i is a current control circuit. Also, the compare circuit 1i is constituted by an arithmetic circuit to calculate  $D(i, j) = S(i, j) - S(i, j+1)$  during the display period Tj. Then, if  $D(i, j) \leq 0$ , the current volume flow through the discharge circuit 30i during the blanking period tj is restricted as maximum and residual electric charges are not discharged from the data electrode Xi. If  $D(i, j) > 0$ , the current volume flow through the discharge circuit 30i during the blanking period tj is changed depending on the value of D(i, j). That is, the smaller the D(i, j) value is, the larger the current volume discharged through the discharge circuit 30i is restricted. By controlling as above, even if  $S(i, j) > S(i, j+1)$ , electric charges are not discharged wastefully from the data electrode during the blanking period. Thus, the electric power saving effect is further enhanced.

**[0041]** While there has been described what are at present considered to be preferred embodiments of the invention, it will be understood that various modifications may be made thereto, and it is intended that the appended claims cover all such modifications as fall within the true spirit and scope of the invention.

## Claims

1. A driving device of an organic thin film EL display which comprises display elements composed of organic thin film EL light-emitting elements (P(i,j)) connected to respective intersections of data electrodes (Xi-1, Xi, Xi+1) and scanning electrodes (Yj-1, Yj, Yj+1) arrayed in a matrix, wherein while the scanning electrode is scanned at predetermined periods, the display element emits light in response to a signal applied to the data electrode in synchronization with this scanning; characterized in that

said driving device comprising,

a comparator (1i-1, 1i, 1i+1) comparing a signal voltage applied to the display element on a predetermined data electrode on the scanning electrode for the current display period and a signal voltage applied to the display element on this data electrode and on the scanning electrode for the next display period; and  
 a controller (3i-1, 3i, 3i+1) controlling a discharge of residual electric charges from the data electrode on the currently displaying scanning electrode during a blanking period immediately before the next display period depending on the comparison result by the comparator.

2. A driving device of an organic thin film EL display which comprises display elements composed of organic thin film EL light-emitting elements (P(l,j)) connected to respective intersections of data electrodes (Xi-1, Xi, Xi+1) and scanning electrodes (Yj-1, Yj, Yj+1) arrayed in a matrix; wherein while the scanning electrode is scanned at predetermined periods, the display element emits light in response to a signal applied to the data electrode in synchronization with this scanning; characterized in that said driving device comprising,

a comparator (1i-1, 1i, 1i+1) comparing a signal voltage applied to the display element on a predetermined data electrode on the scanning electrode for the current display period and a signal voltage applied to the display element on this data electrode and on the scanning electrode for the next display period; and  
 a controller (30i-1, 30i, 30i+1) controlling a quantity of residual electric charges discharged from the data electrode on the currently displaying scanning electrode during a blanking period immediately before the next display period depending on the comparison result by the comparator.

3. The driving device of an organic thin film EL display according to claim 1 or 2, characterized in that

the controller (3i-1, 3i, 3i+1, 30i-1, 30i, 30i+1) controls the data electrode (Xi-1, Xi, Xi+1) of the currently displaying scanning electrode so that residual electric charges are discharged during the blanking period immediately before the next display period, if an image signal voltage S(i, j) for the current discharge period is larger than an image signal voltage S(i, j+1) for the next display period; and  
 the data electrode is controlled so that residual electric charges are not discharged, if an

image signal voltage S(i, j) for the current discharge period is equal or less than an image signal voltage S(i, j+1) for the next display period.

4. The driving device of an organic thin film EL display according to any one of claims 1 to 3, characterized in that

said controller controls a discharge circuit which holds said data electrode to the ground level.

5. The driving device of an organic thin film EL display according to any one of claims 1 to 4, characterized by further comprising

an image memory (2) having a memory capacity of at least enough for 2 x m (m: the number of data electrodes) is provided; characterized in that

the signal voltage applied to each of the data electrodes on the currently displaying scanning electrode for a display period is stored in said image memory;

the signal voltage applied to each of the data electrodes on the scanning electrode for the next display period is stored; and

the comparator compares the data in the image memory.

6. The driving device of an organic thin film EL display according to claim 4 or 5, characterized in that

a number of said discharge circuits is same as the number of the data electrodes (m).

7. A method for driving an organic thin film EL display comprising display elements composed of organic thin film EL light-emitting elements (P(l,j)) and connected to respective intersections of data electrodes (Xi-1, Xi, Xi+1) and scanning electrodes (Yj-1, Yj, Yj+1) disposed in a matrix; and a scanning electrode scanned at predetermined periods, while said display element emits light in response to a signal applied to the data electrode in synchronization with this scanning; said method characterized by comprising the steps of:

comparing a signal voltage applied to the display element on a predetermined data electrode on the scanning electrode for the current display period and a signal voltage applied to the display element on the data electrode and on the scanning electrode for the next display period; and

controlling the data electrode so as to be in the discharge state during a blanking period imme-

diately before the display period when the signal voltage applied to the display element on the predetermined data electrode on the scanning electrode for the current display period is larger than the signal voltage applied to the display element on the data electrode for the next display period or controlling the data electrode does so as not to be in the discharge state otherwise.

5  
10

15

20

25

30

35

40

45

50

55

FIG. 1

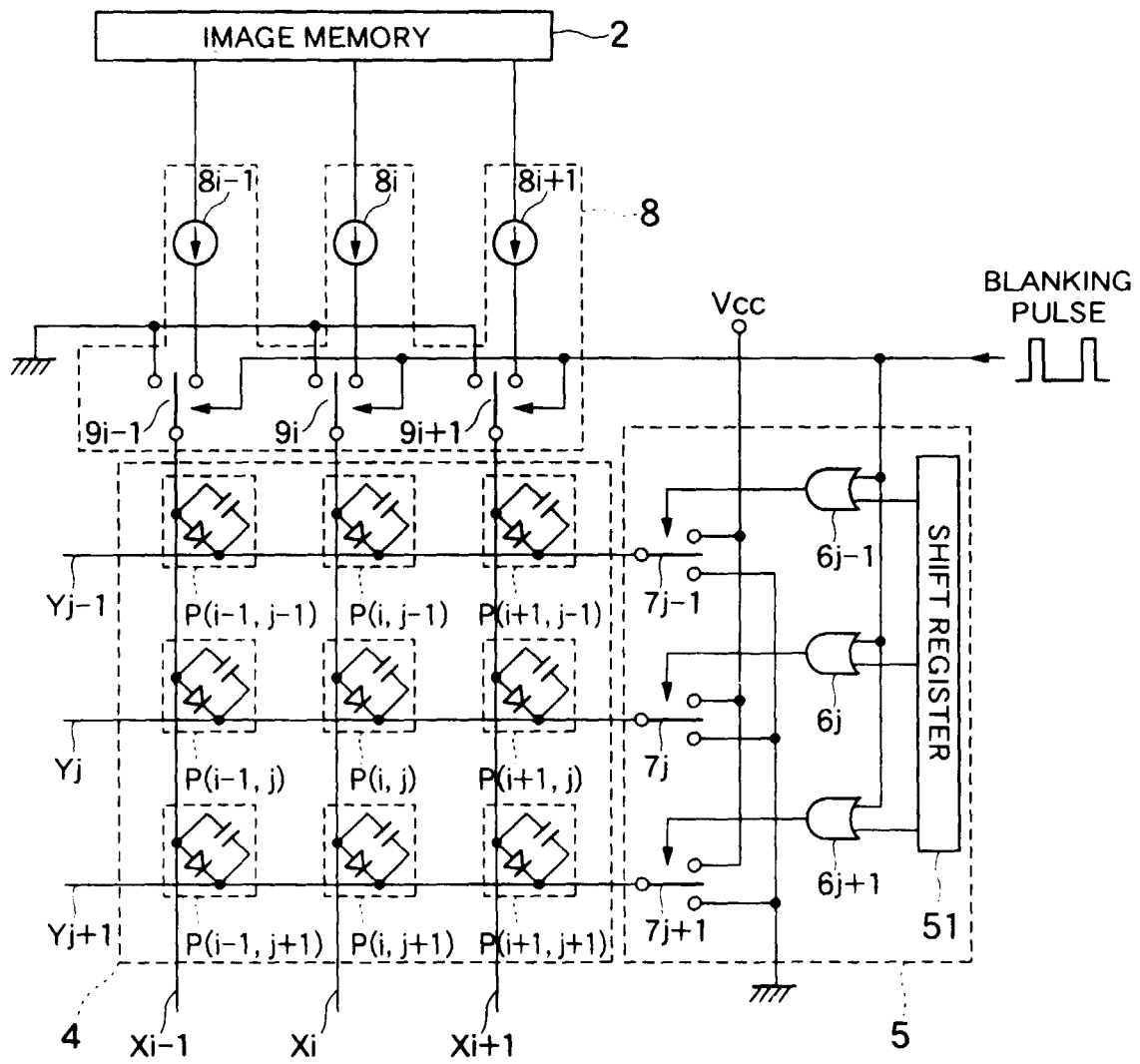

FIG. 2

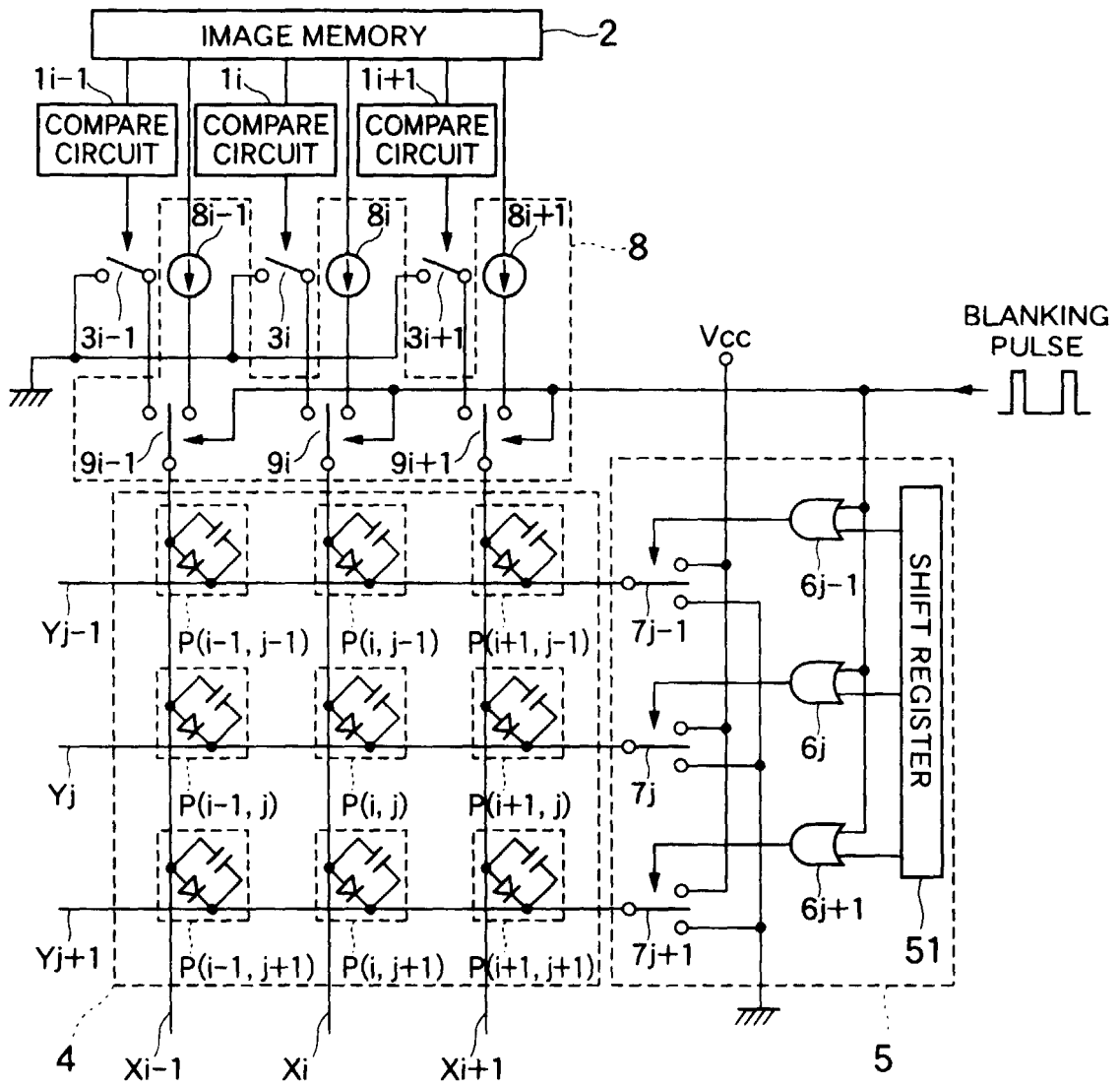

FIG. 3

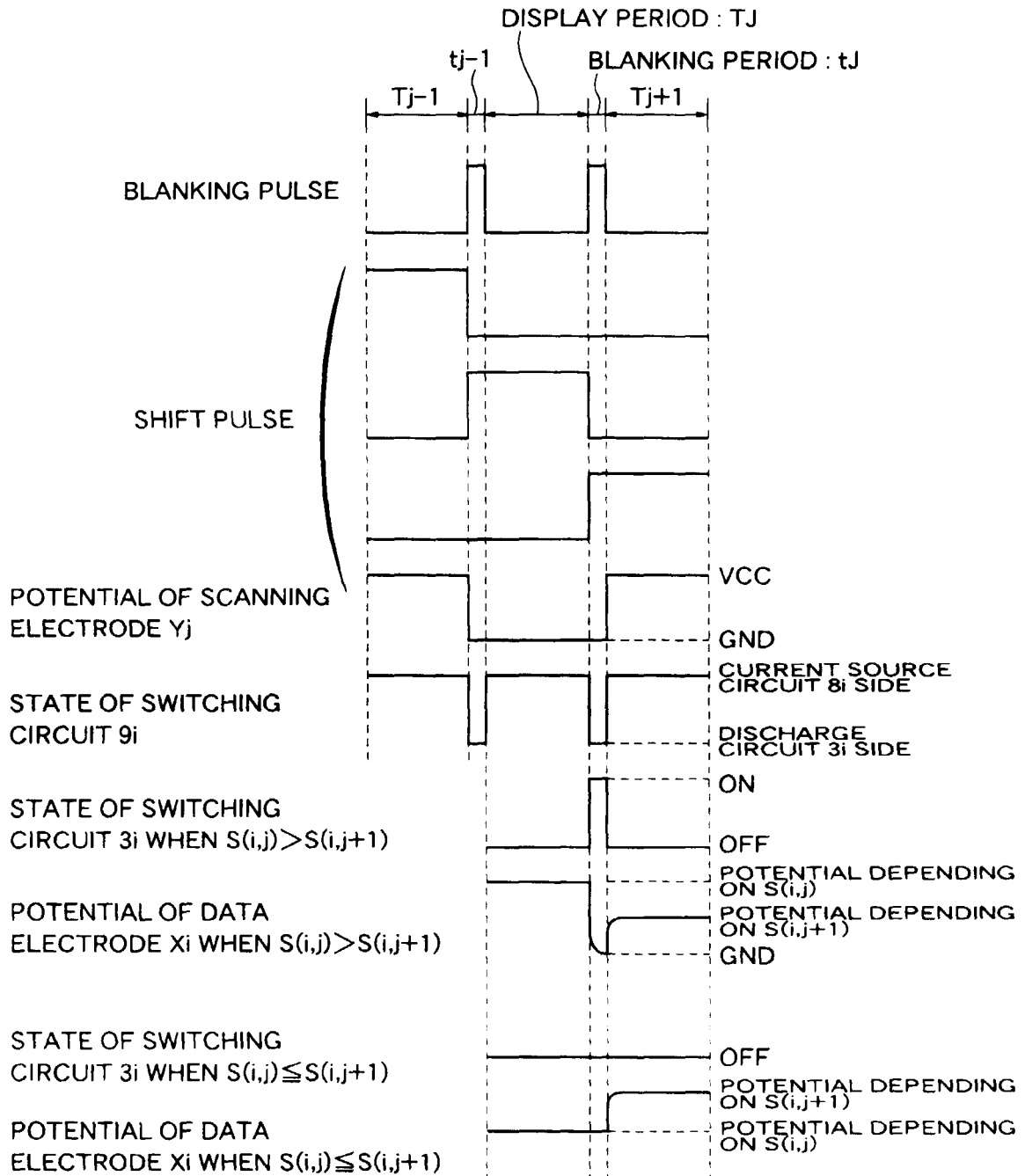

FIG. 4

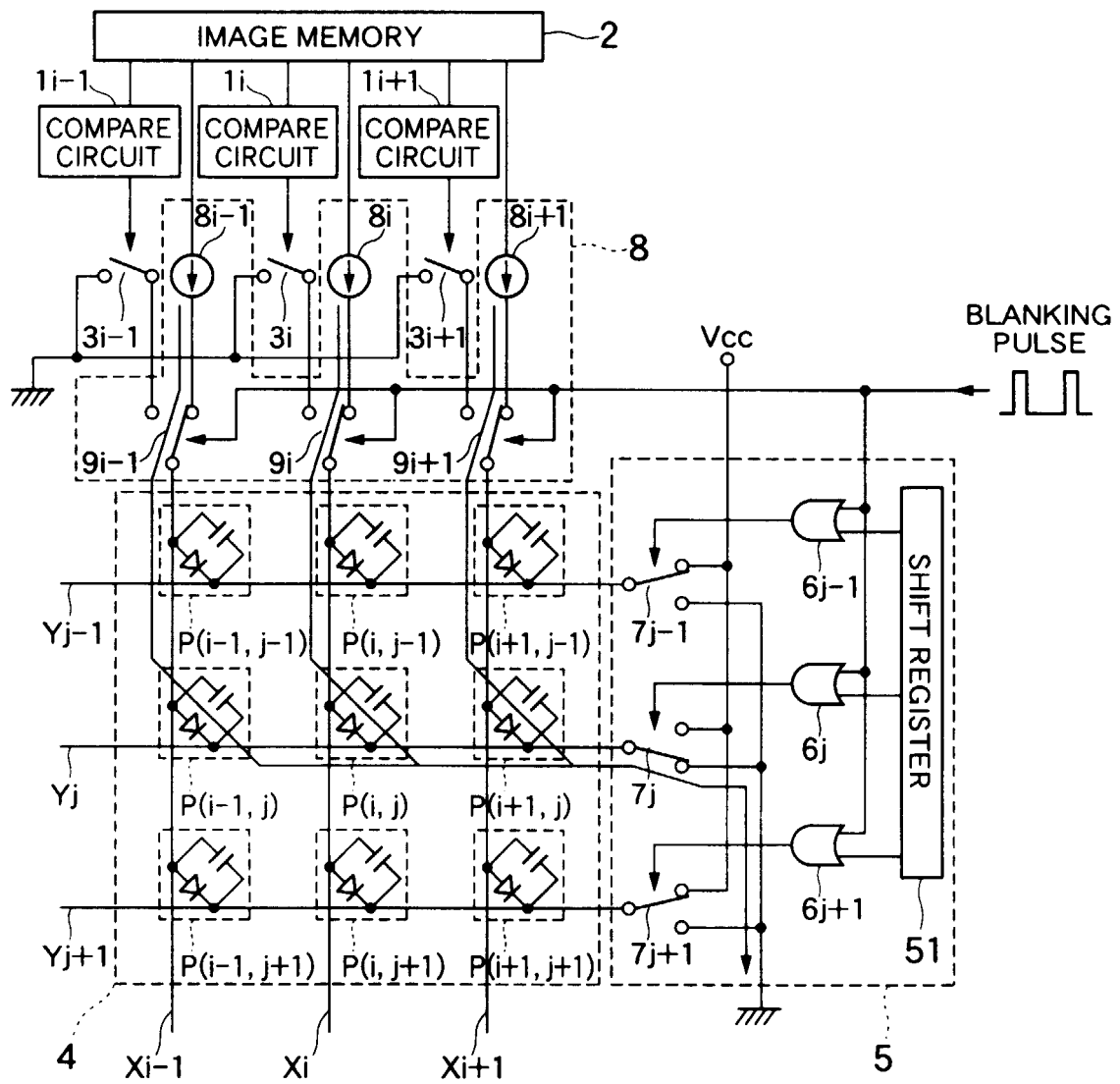

FIG. 5

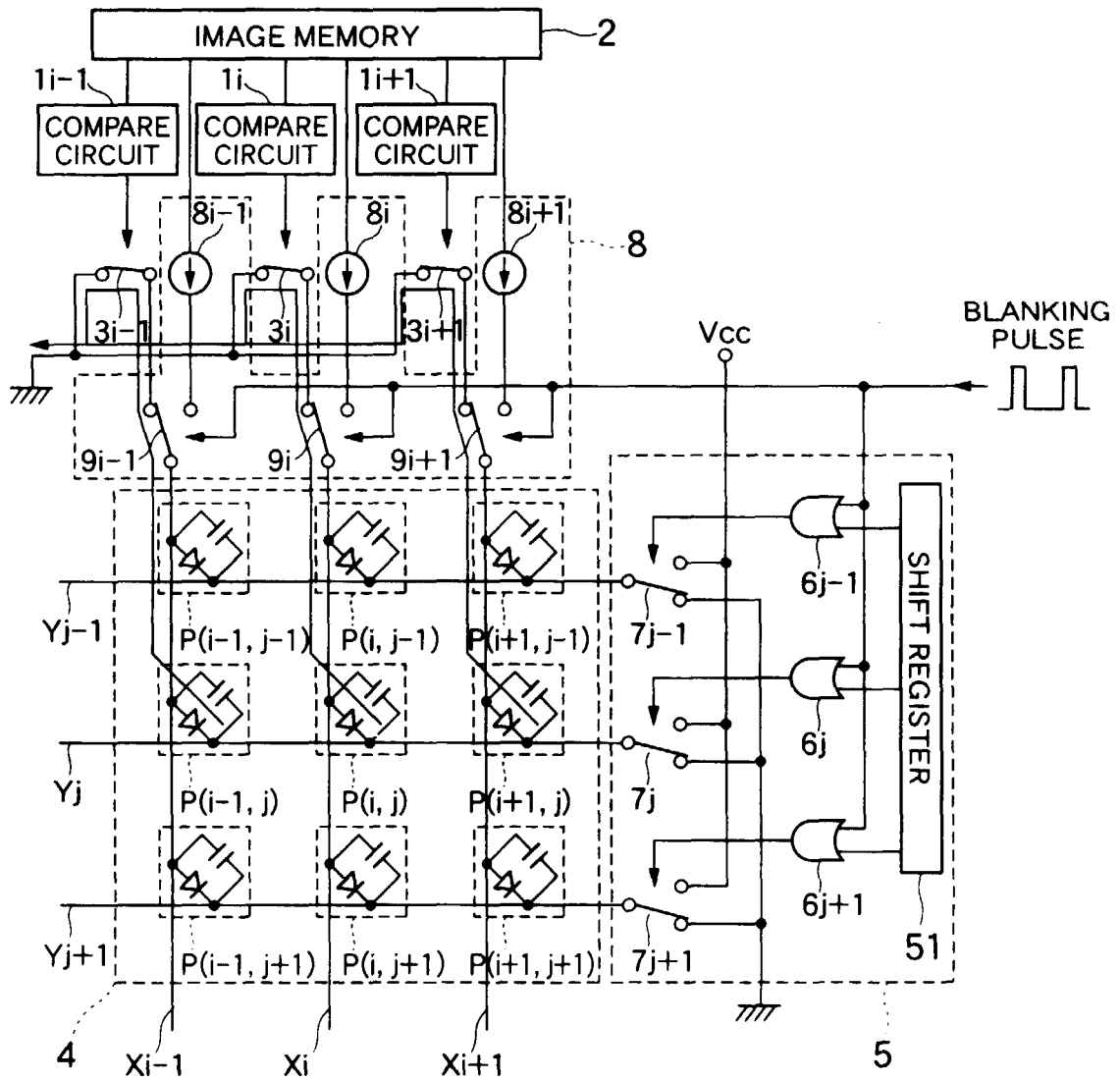

FIG. 6

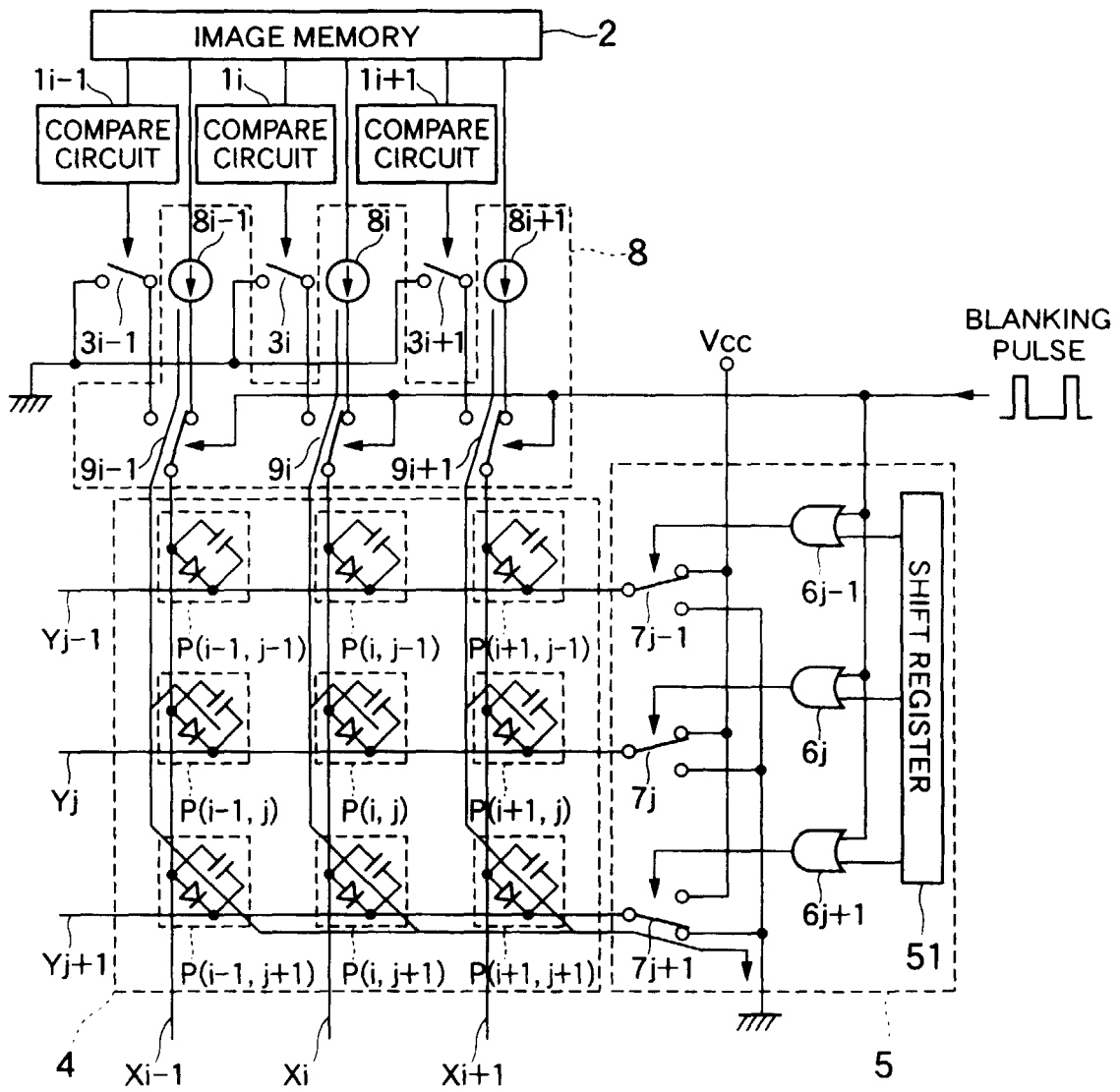

FIG. 7

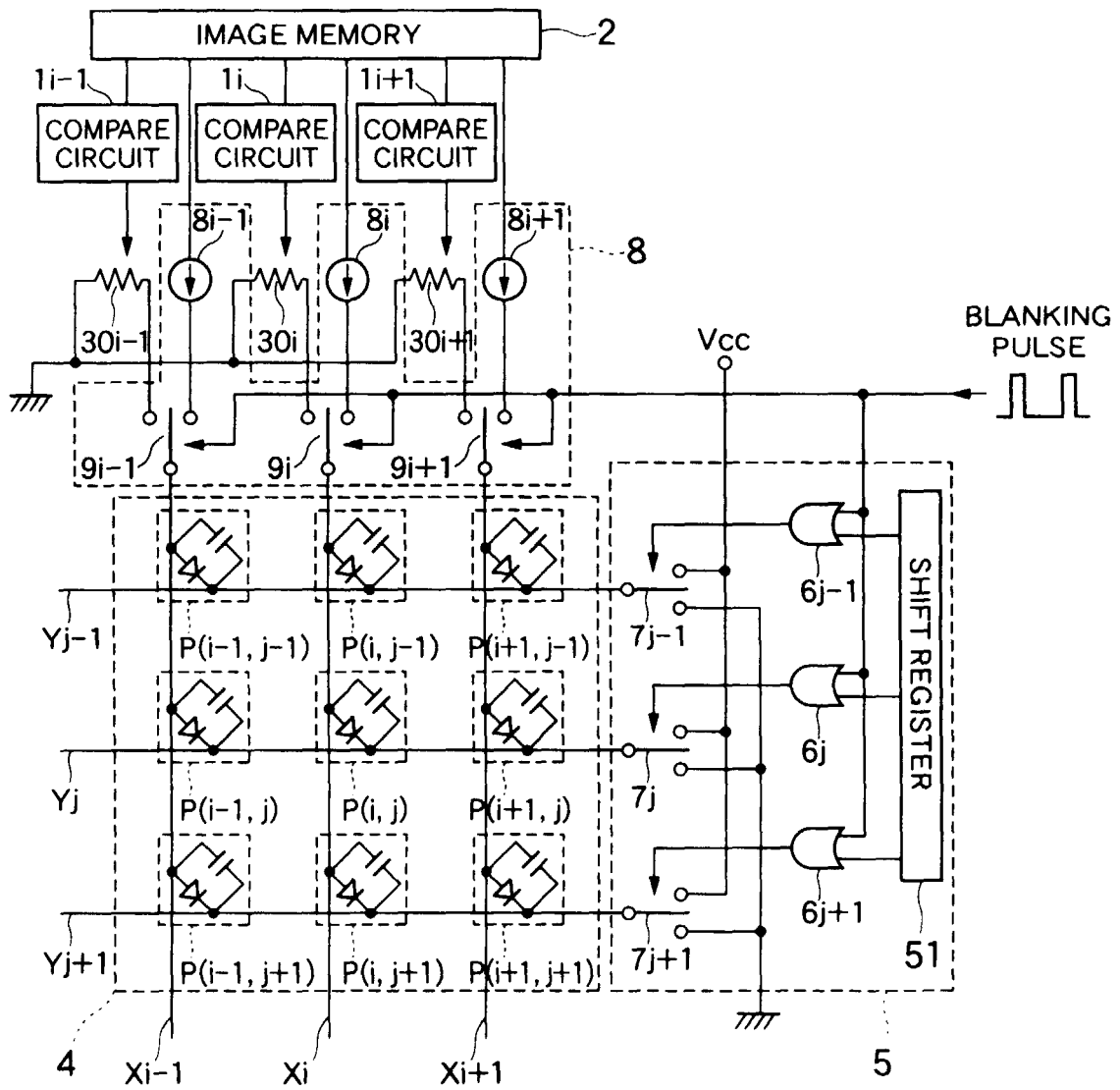
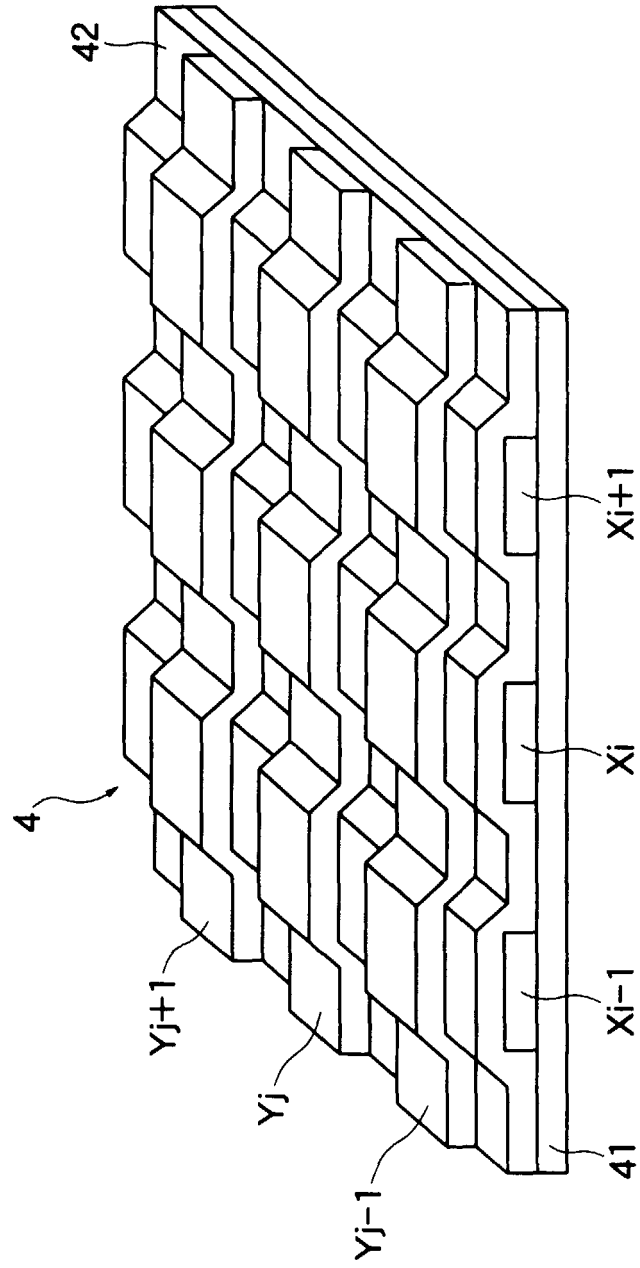

FIG. 8



专利名称(译)	有机薄膜EL显示器的驱动装置和驱动方法		
公开(公告)号	<a href="#">EP1091340A2</a>	公开(公告)日	2001-04-11
申请号	EP2000121697	申请日	2000-10-04
申请(专利权)人(译)	NEC公司		
当前申请(专利权)人(译)	NEC公司		
[标]发明人	IKETSU YUICHI SAKAGUCHI YOSHIKAZU		
发明人	IKETSU, YUICHI SAKAGUCHI, YOSHIKAZU		
IPC分类号	G09G3/30 G09G3/20 G09G3/32 H01L51/50 H05B33/08 H05B33/12 H05B33/14		
CPC分类号	G09G3/3216 G09G2310/0251 G09G2330/023 G09G2340/16		
优先权	1999284167 1999-10-05 JP		
其他公开文献	EP1091340B1 EP1091340A3		
外部链接	<a href="#">Espacenet</a>		

摘要(译)

比较器 (比较在当前显示周期的扫描电极 ( $Y_j$ ) 上的预定数据电极 ( $X_i$ ) 上施加到显示元件  $P(i, j)$  的信号电压  $S(i, j)$  的扫描电极  $Y(j+1)$  上的数据电极 ( $X_i$ ) 上的显示元件  $P(i, j+1)$  上施加的电压根据比较器的比较结果, 在紧接在下一个显示周期之前的消隐周期期间从数据电极 ( $X_i$ ) 排出的电荷或一定量的残余电荷。

FIG. 2

