

(19)



(11)

EP 2 610 843 B1

(12)

EUROPEAN PATENT SPECIFICATION

(45) Date of publication and mention of the grant of the patent:
03.04.2019 Bulletin 2019/14

(51) Int Cl.:
G09G 3/32^(2016.01)

(21) Application number: **12188203.9**

(22) Date of filing: **11.10.2012**

(54) **Power supply device, display apparatus having the same, and power supply method**

Stromversorgungsvorrichtung, Anzeigevorrichtung damit, und Stromversorgungsverfahren

Dispositif d'alimentation électrique, dispositif d'affichage l'utilisant et procédé d'alimentation électrique

(84) Designated Contracting States:
**AL AT BE BG CH CY CZ DE DK EE ES FI FR GB
GR HR HU IE IS IT LI LT LU LV MC MK MT NL NO
PL PT RO RS SE SI SK SM TR**

(30) Priority: **28.12.2011 KR 20110144994**

(43) Date of publication of application:
03.07.2013 Bulletin 2013/27

(73) Proprietor: **Samsung Electronics Co., Ltd.
Suwon-si, Gyeonggi-do, 443-742 (KR)**

(72) Inventors:
• **Hyeon, Byeong-cheol
Gyeonggi-do (KR)**
• **Yi, Kang-hyun
Chungcheongnam-do (KR)**

(74) Representative: **Appleyard Lees IP LLP
15 Clare Road
Halifax HX1 2HY (GB)**

(56) References cited:
**US-A1- 2002 070 914 US-A1- 2008 224 629
US-A1- 2011 084 992**

EP 2 610 843 B1

Note: Within nine months of the publication of the mention of the grant of the European patent in the European Patent Bulletin, any person may give notice to the European Patent Office of opposition to that patent, in accordance with the Implementing Regulations. Notice of opposition shall not be deemed to have been filed until the opposition fee has been paid. (Art. 99(1) European Patent Convention).

Description**BACKGROUND****1. Field**

[0001] Apparatuses and methods consistent with exemplary embodiments relate to a power supply device, a display apparatus having the same, and a power supply method, and more particularly to a power supply device, a display apparatus having the same, and a power supply method, which can supply a plurality of driving power levels for RGB colors to an Organic Light Emitting Diode (OLED) panel and perform feedback control for the plurality of driving powers.

2. Description of the Related Art

[0002] A display apparatus processes and displays digital or analog video signals received from outside or various video signals stored in an internal storage device in the form of compression files of various formats.

[0003] Recently, OLED display apparatuses have been actively developed. The OLED display apparatus is a type of flat-panel display, and uses organic light-emitting diodes. The organic light-emitting diode is a self-luminous organic material that emits light by itself using an electroluminescence phenomenon in which fluorescent organic compounds emit light in response to current flow thereto. The OLED display apparatus is made as a thin type display apparatus, and has a wide viewing angle and a quick response speed. Further, the OLED display apparatus has advantageous price competitiveness due to better picture quality than the LCD in a small-size screen and a simple manufacturing process.

[0004] However, the OLED display apparatus in the related art has unnecessary power consumption because it is driven using only single driving power level. Specifically, although the sizes of the driving voltage levels required for RGB color channels are different from one another, the OLED display apparatus in the related art receives and uses only one driving power level regardless of the channels, and thus it causes unnecessary power consumption in the channels that do not require high driving voltage. Document US201184992 describes a system wherein the voltage applied per color to the OLED pixels by the voltage source is modified in the voltage source according to the APL, wherein the voltage source is regulated by a feedback loop and the APL control corresponds to a feedforward loop.

[0005] Document US2002070914 describes a detailed implementation of a power supply for an LED backlight performing feedback control of the output voltages and feedforward control according to the video signal. The power supply comprises a rectifier, a DC/DC converter and output switching units to perform the feedback control according to a different control strategy and presenting a different design (a switch controlling high/low time

according to control signal wherein an offset can be provided to control backlight luminance).

SUMMARY

[0006] Exemplary embodiments may address at least the above problems and/or disadvantages and other disadvantages not described above. The embodiments are according to claims 1 to 7.

BRIEF DESCRIPTION OF THE DRAWINGS

[0007] The above and/or other aspects, features and advantages of the present disclosure will become more apparent by describing certain exemplary embodiments, with reference to the accompanying drawings, in which:

FIG. 1 is a block diagram illustrating a display apparatus according to an exemplary embodiment;

FIG. 2 is a block diagram illustrating the detailed configuration of a display apparatus according to an exemplary embodiment;

FIG. 3 is a block diagram illustrating the detailed configuration of a power supply device according to an exemplary embodiment;

FIG. 4 is a diagram illustrating the detailed configuration of a converter and a power controller;

FIG. 5 is a diagram illustrating the detailed configuration of a switching unit;

FIG. 6 is a diagram illustrating an example of a video signal;

FIG. 7 is a diagram illustrating the configuration of an OLED panel; and

FIG. 8 is a flowchart illustrating a power supply method according to an exemplary embodiment.

DETAILED DESCRIPTION OF EXEMPLARY EMBODIMENTS

[0008] Hereinafter, certain exemplary embodiments are described in greater detail below with reference to the accompanying drawings.

[0009] In the following description, like drawing reference numerals are used for the like elements, even in different drawings. The matters defined in the description, such as detailed construction and elements, are provided to assist in a comprehensive understanding of exemplary embodiments. However, exemplary embodiments can be carried out without those specifically defined matters. Also, well-known functions or constructions are not described in detail since that would obscure the invention with unnecessary detail.

[0010] FIG. 1 is a block diagram illustrating a configuration of a display apparatus according to an exemplary embodiment.

[0011] Referring to FIG. 1, a display apparatus 100 according to an exemplary embodiment may include an OLED panel 110, a video signal providing unit 120, and

a power supply 200.

[0012] The OLED panel 110 receives a video signal and a plurality of driving powers for RGB colors, and displays an image. Specifically, the OLED panel 110 may display the image corresponding to the video signal provided from the video signal providing unit 120 to be described later and the plurality of driving powers supplied from the power supply 200. For this, the OLED panel 110 may be provided with a plurality of pixels that include organic light emitting diodes. The detailed configuration of the OLED panel 110 will be described later with reference to FIG. 7.

[0013] The video signal providing unit 120 provides the video signal to the OLED panel 110. Specifically, the video signal providing unit 120 supplies video data and/or various video signals for displaying the video data to the OLED panel 110. Here, the video signal has a light emitting period for transferring information on light emitting levels and an addressing period for transferring address information to which the light emitting period is applied, and one frame period has one light emitting period and one addressing period.

[0014] The power supply 200 supplies the plurality of driving powers to the OLED panel 110, and performs individual feedback control for each of the plurality of driving powers. Here, the feedback control means a control that compares a control amount with a target value and performs a correction operation to match them. Accordingly, the power supply 200 may perform the feedback control with respect to the plurality of driving powers using preset driving voltage values for the RGB colors as target values and the plurality of output driving voltage values as the control amounts. The detailed configuration and operation of the power supply 200 will be described later with reference to FIGS. 3 to 5.

[0015] A plurality of output lines 260 may provide the plurality of driving power levels including different voltage values and/or different current values from the power supply 200 to the OLED panel 110. The plurality of output lines 260 may be configured by one cable or a plurality of cables.

[0016] Hereinafter, the detailed configuration of the display apparatus 100 will be described with reference to FIG. 2.

[0017] FIG. 2 is a block diagram illustrating the detailed configuration of a display apparatus according to an exemplary embodiment.

[0018] Referring to FIG. 2, the display apparatus 100 according to an exemplary embodiment includes an OLED panel 110, a video signal providing unit 120, a broadcast receiving unit 130, a signal separation unit 135, an audio/video (A/V) processing unit 140, an audio output unit 145, a storage 150, a communication interface unit 155, an operation unit 160, a controller 170, and a power supply 200.

[0019] Since the operations of the OLED panel 110 and the power supply 200 are substantially the same as those described above, the duplicate description thereof

will be omitted. In the illustrated example, the power supply 200 supplies the power only to the OLED panel 110 and the controller 170. However, the power supply 200 can provide the power to all of the elements that require the power in the display apparatus 100.

[0020] The broadcast receiving unit 130 receives a broadcasting signal by wire or wirelessly from a broadcasting station or a satellite, and demodulates the received broadcasting signal.

[0021] The signal separation unit 135 separates the broadcasting signal into a video signal, an audio signal, and an additional information signal. Then, the signal separation unit 135 transmits the video signal and the audio signal to the A/V processing unit 140.

[0022] The A/V processing unit 140 performs signal processing, such as video decoding, video scaling, audio decoding, and the like, with respect to the video signal and the audio signal input received from the broadcast receiving unit 130 and/or the storage 150. Then, the A/V processing unit 140 outputs the video signal to the video signal providing unit 120, and outputs the audio signal to the audio output unit 145.

[0023] In the case of storing the received video and audio signals in the storage 150, the A/V processing unit 140 may output the video and audio signals in a compressed form to the storage 150.

[0024] The audio output unit 145 converts the audio signal output from the A/V processing unit 140 into sound to output the sound to a speaker (not illustrated) or outputs the audio signal to an external device connected through an external output terminal (not illustrated).

[0025] The video signal providing unit 120 generates a Graphic User Interface (GUI) to be provided to a user. Then, the video signal providing unit 120 adds the generated GUI to an image output from the A/V processing unit 140. The video signal providing unit 120 also provides a video signal that corresponds to the image to which the GUI has been added to the OLED panel 110. Accordingly, the OLED panel 110 displays various kinds of information provided by the display apparatus 100 and the image transferred from the video signal providing unit 120.

[0026] Further, the storage 150 may store video content. Specifically, the storage 150 may receive the video content in which video and audio signals have been compressed from the A/V processing unit 140 to store the video content, and may output the stored video content to the A/V processing unit 140 under the control of the controller 170. The storage 150 may be implemented by a hard disk, a nonvolatile memory, a volatile memory, and the like.

[0027] The operation unit 160 is implemented by a touch screen, a touchpad, key buttons, a keypad, and the like, and provides the user operation of the display apparatus 100. In this exemplary embodiment, it is exemplified that a control command is input through the operation unit 160 provided on the display apparatus 100. However, the operation unit 160 may receive an input of

the user operation from an external control device (for example, remote controller).

[0028] The communication interface unit 155 is formed to connect the display apparatus 100 to an external device (not illustrated), and may be connected to the external device through a Local Area Network (LAN), the Internet, or a Universal Serial Bus (USB) port.

[0029] The controller 170 controls the overall operation of the display apparatus 100. Specifically, the controller 170 may control the video signal providing unit 120 and the OLED panel 110 so that an image is displayed according to the control command input through the operation unit 160.

[0030] As described above, the display apparatus according to this exemplary embodiment supplies separate driving powers for RGB colors to the OLED panel, performs separate feedback controls with respect to the respective driving powers, and provides adaptive driving powers to the OLED panel. Accordingly, the power consumption of the display apparatus 100 can be reduced.

[0031] Although it is exemplified that the above-described functions are applied to the display apparatus that receives and displays the broadcast, the power supply device of an exemplary embodiment may be applied to any electronic device having the OLED panel.

[0032] Although it is exemplified that the power supply 200 is included in the display apparatus 100 as described above, the function of the power supply 200 may be implemented by a separate device. Hereinafter, a separate power supply device that performs the same function as the power supply 200 will be described with reference to FIG. 3.

[0033] FIG. 3 is a block diagram illustrating the detailed configuration of a power supply device according to an exemplary embodiment.

[0034] Referring to FIG. 3, the power supply 200 may include a rectifier 210, a PFC device 220, a converter 230, a switching unit 240, and a power controller 250.

[0035] The rectifier 210 rectifies an external AC power. Specifically, the rectifier 210 may be implemented by a bridge full-wave rectifying circuit.

[0036] The PFC device 220 makes the voltage and current of the rectified AC power in the same phase. Specifically, the PFC device 220 may make the voltage and current of the AC power rectified by the rectifier 210 to be in phase. Then, the PFC device 220 may transform the AC voltage of which the voltage and current are made in the same phase into a DC voltage. Although it is exemplified that the PFC device 220 transforms the AC power into the DC voltage in this exemplary embodiment, a converter 230 to be described later may perform the conversion to the DC voltage.

[0037] The converter 230 may convert the DC voltage into a plurality of voltages to output the plurality of voltages through a multi-winding insulation transformer. On the other hand, the converter 230 may transform the AC power in which the voltage and current are made in the same phase. Specifically, the converter 230 may be im-

plemented by a discrete LLC converter that is a resonant converter, and the detailed configuration of the discrete LLC converter will be described later with reference to FIG. 4.

[0038] The switching unit 240 selectively provides the transformed DC voltage to the plurality of output terminals 270, 272, 274. Specifically, the switching unit 240 may be implemented by a plurality of resonant synchronous switching devices, which will be described later with reference to FIG. 5.

[0039] The power controller 250 controls the switching unit 240 so that the feedback control is performed with respect to the plurality of driving voltage values output from the plurality of output terminals 270, 272, 274. Specifically, because the power supply 200 provides large current to the OLED panel, the voltage at an input terminal of the OLED panel may be lower than the driving voltage output from the switching unit 240. That is, the driving voltage may be dropped by the cable, and the power controller 250 may perform the feedback control with respect to the respective driving voltages of the plurality of driving powers output from the plurality of output terminals 270, 272, 274.

[0040] Then, the power controller 250 may control the converter 230 to perform the feed-forward control with respect to the driving powers output from the plurality of output terminals 270, 272, 274 based on the video signal. Here, the feed-forward control is a control method that predicts in advance the change of the control amount due to disturbance and performs the control operation corresponding to this to make a quick response. In this exemplary embodiment, the driving current for the RGB colors for the OLED panel 110 is predicted on the basis of the video signal provided to the OLED panel 110, and the plurality of driving powers supplied to the OLED panel 110 are controlled on the basis of the predicted driving current for the RGB colors.

[0041] Accordingly, the power controller 250 may predict the driving current for the RGB colors to be supplied to the OLED panel based on the luminance information of the input video signal, and control the converter 230 based on the predicted driving current for the RGB colors. Here, the luminance information includes information on the light emitting levels for the RGB colors of the OLED panel and timing information to which the light emitting levels are applied. Accordingly, the power supply 200 may output the plurality of driving powers that correspond to the luminance information for the RGB colors in the timing that corresponds to the luminance information using a lookup table which stores a plurality of driving current values that correspond to the plurality of light emitting levels of the OLED panel. This feed-forward control may be performed simultaneously with the above-described feedback control.

[0042] Although it is exemplified that the video signal itself that is provided to the OLED panel 110 is received and used in this exemplary embodiment, it is also possible to receive and use only information required during

the feed-forward control (for example, luminance information or predicted driving current values) in implementation.

[0043] FIG. 4 is a diagram illustrating the detailed configuration of a converter and a power controller of FIG. 3.

[0044] Referring to FIG. 4, the converter 230 is a discrete LLC converter that is a resonant converter. Specifically, the converter 230 may be implemented by an LLC half-bridge resonant converter that uses leakage inductance as resonant inductor using a separation type transformer bobbin. Although it is exemplified that the converter 230 is implemented using the LLC half-bridge resonant converter in this exemplary embodiment, the converter 230 may be implemented in a form that uses other LLC converters.

[0045] The power controller 250 may include an analog-to-digital converter (ADC) 251, a control core 253, and a frequency modulation unit 255.

[0046] The ADC 251 may detect the plurality of driving powers. Specifically, the ADC 251 detects voltage values of the plurality of driving powers output from the switching unit 240, and may provide the detected voltage values of the plurality of driving powers to the control core 253 as digital values.

[0047] The control core 253 may perform feedback control and feed-forward control with respect to the plurality of driving powers output from the power supply 200. Specifically, the control core 253 may perform operations for the feedback control and the feed-forward control with respect to the plurality of driving powers based on the digital voltage values of the driving powers provided from the ADC 251 and the video signal provided from the video signal providing unit 120.

[0048] The frequency modulation unit 255 may modulate the control signal based on the result of the operation into a frequency signal, and may provide the modulated control signal to the converter 230 and the switching unit 240.

[0049] FIG. 5 is a diagram illustrating the detailed configuration of a switching unit of FIG. 3.

[0050] Referring to FIG. 5, the switching unit 240 includes a plurality of resonant synchronous switching devices 241, 242, and 243.

[0051] The resonant synchronous switching devices 241, 242, and 243 selectively provide the power generated by the converter 240 to the output terminals 270, 272, 274 under the control of the power controller 250. Specifically, each of the resonant synchronous switching devices 241, 242, and 243 may include a switching element, an inductor, and a diode.

[0052] Each of the switching elements SW1, SW2, and SW3 has one end connected to an output terminal of the converter 230 and the other end commonly connected to an anode of a diode D5, D6, or D7 and one end of an inductor L1, L2, or L3.

[0053] Each of the diodes D5, D6, and D7 has an anode commonly connected to the other end of the switching element SW1, SW2, or SW3 and one end of the inductor

L1, L2, or L3 and a cathode connected to ground.

[0054] Each of inductors L1, L2 and L3 has one end commonly connected to the other end of the switching element SW1, SW2, or SW3 and an anode of the diode D5, D6, or D7 and the other end connected to the output terminal 270, 272, or 274 that output the driving power.

[0055] As described above, the switching unit 240 according to this exemplary embodiment can output the plurality of driving powers without employing a separate multi-channel buck converter because that it uses the plurality of resonant synchronous switching devices. Further, because the switching unit 240 does not use the multi-channel buck converter, the volume of the power supply device can be reduced and thus the manufacturing cost can be saved.

[0056] FIG. 6 is a diagram illustrating an example of a video signal.

[0057] Referring to FIG. 6, the video signal has a preset video frame period, and the video frame period has a light emitting period in which the OLED panel emits light and an addressing period in which light emission is not performed. Further, different OLED light emitting level adjustment voltage values are provided for the respective light emitting periods.

[0058] Accordingly, in this exemplary embodiment, the feed-forward control is performed using OLED light emitting level adjustment voltage value information in the light emitting period and information on the light emitting period to which the corresponding adjustment voltage value is applied (that is, timing information). Specifically, the converter 230 may be controlled so that, in the first frame, the driving current to be provided to the OLED panel is predicted on the basis of an average light emitting level voltage required for the RGB color channels, and the DC voltage corresponding to the predicted driving current is generated.

[0059] FIG. 7 is a diagram illustrating the configuration of an OLED panel of FIGS. 1 and 2.

[0060] Referring to FIG. 7, the OLED panel includes a plurality of pixels which are classified into a plurality of pixel groups for the RGB colors and are arranged in a matrix form. Here, the plurality of pixel groups may include an R pixel group, a G pixel group, and a B pixel group. The respective pixel groups receive different driving voltage values and/or different current values.

[0061] Although it is exemplified that the pixels are classified into three pixel groups in this exemplary embodiment, it is also possible to classify the pixels of the OLED panel into two or four or more pixel groups. For example, in the case where the OLED panel is classified into RGBW (red, green, blue, white) pixel groups, the power supply 200 may be implemented to provide four driving powers to the OLED panel.

[0062] FIG. 8 is a flowchart illustrating a power supply method according to an exemplary embodiment.

[0063] Referring to FIG. 8, an external AC power is rectified (S810). Specifically, the external AC power may be rectified using a bridge full-wave rectifying circuit.

[0064] Then, a voltage and current of the rectified AC power are made to be in the same phase (S820). Specifically, the voltage and current of the rectified AC power may be made in the same phase using the PFC circuit.

[0065] Then, the AC power of which the voltage and current have been made in the same phase is transformed into a DC voltage of a preset level (S830). Specifically, the AC power may be converted into the DC voltage of the preset level using the discrete LLC converter.

[0066] Then, the DC voltage of the preset level is converted into a plurality of driving power levels (S840). Specifically, the transformed DC voltage may be converted into a plurality of driving power levels for the RGB colors.

[0067] Then, the plurality of converted driving power levels may be output to the OLED panel (S850).

[0068] Then, a feedback control may be performed with respect to the plurality of converted driving powers (S860). On the other hand, driving current values for the RGB colors supplied to the OLED panel may be predicted based on luminance information of the input video signal and a feed-forward control is performed based on the predicted driving current values (S870).

[0069] Accordingly, the power supply method according to this exemplary embodiment supplies separate driving powers for RGB colors to the OLED panel, performs separate feedback controls with respect to the respective driving powers, and adaptively provides driving powers to the OLED panel. Accordingly, the power consumption of the display apparatus 100 can be reduced. The power supply method illustrated in FIG. 8 may be executed by the display apparatus having the configuration illustrated in FIG. 1 or the power supply device having the configuration illustrated in FIG. 3. Further, the power supply method may be executed by other display apparatuses or power supply devices having other configurations.

[0070] The foregoing exemplary embodiments and advantages are merely exemplary and are not to be construed as limiting. The present teaching can be readily applied to other types of apparatuses. Also, the description of the exemplary embodiments is intended to be illustrative, and not to limit the scope of the claims, and many alternatives, modifications, and variations will be apparent to those skilled in the art.

Claims

1. A display apparatus comprising:

an OLED (Organic Light Emitting Diode) panel unit receiving an input of a video signal and a plurality of driving power levels for RGB colors and displaying an image;
a video signal providing unit providing the video signal to the OLED panel unit; and
a power supply unit supplying the plurality of driving power levels to the OLED panel unit

wherein the power supply unit is operable to predict driving currents for the RGB colors to be supplied to the OLED panel unit based on luminance information of the video signal and to perform feed forward control with respect to the plurality of driving power levels based on the predicted driving currents; **characterized in that:** the power supply unit comprises:

a rectifying unit arranged to rectify an external AC power;
a power factor correction, PFC, unit arranged to make voltage and current of the rectified AC power to be in the same phase and to transform the AC voltage into a DC voltage;
a convertor arranged to convert the DC voltage into a plurality of voltages to output the plurality of voltages through a multi-winding insulation transformer;
a plurality of output terminals arranged to output the plurality of voltages;
a plurality of switching units arranged to selectively provide the plurality of voltages of the convertor to the plurality of output terminals; and
a power control unit arranged to control the plurality of switching units to perform feedback control with respect to the plurality of voltages output from the output unit, wherein each of the plurality of switching units comprises:

a switching element having one end connected to the convertor;
an inductor having a first end connected to the other end of the switching element and a second end connected to one of the plurality of output terminals; and
a diode having an anode commonly connected to the other end of the switching element and the first end of the inductor and also having a cathode grounded.

2. The display apparatus as claimed in claim 1, wherein the OLED panel unit includes a plurality of pixels that are classified into a plurality of pixel groups for the RGB colors and arranged in a matrix form, and the plurality of pixel groups receives separate driving power levels, respectively.
3. The display apparatus as claimed in claim 1 or 2, wherein the converter is a discrete LLC converter.
4. The display apparatus as claimed in any preceding claim, wherein the luminance information includes

information on light emitting levels for the RGB colors of the OLED panel unit and timing information to which the light emitting levels are applied.

5. A power supply method of a power supply device providing a plurality of driving power levels for RGB colors to an OLED (Organic Light Emitting Diode) panel unit, the method comprising:

providing the video signal to the OLED panel unit;
 predicting driving currents for the RGB colors to be supplied to the OLED panel unit based on luminance information of the video signal and performing feed forward control with respect to the plurality of driving power levels based on the predicted driving currents;
 rectifying an external AC power;
 making voltage and current of the rectified AC power to be in the same phase and to transform the AC voltage into a DC voltage;
 convert the DC voltage into a plurality of voltages to output the plurality of voltages through a multi-winding insulation transformer;
 selectively outputting the plurality of voltages via a plurality of output terminals; and
 controlling the plurality of switching units to perform feedback control with respect to the plurality of voltages output from the output unit, wherein each of the plurality of switching units comprises:

a switching element having one end connected to the convertor;
 an inductor having a first end connected to the other end of the switching element and a second end connected to one of the plurality of output terminals; and
 a diode having an anode commonly connected to the other end of the switching element and the first end of the inductor and also having a cathode grounded.

6. The power supply method as claimed in claim 5, wherein the converting step converts the DC voltage into the plurality of driving power levels having different voltage levels for the RGB colors.
7. The power supply method as claimed in claim 5 or 6, wherein the luminance information includes information on light emitting levels for the RGB colors of the OLED panel unit and timing information to which the light emitting levels are applied.

Patentansprüche

1. Anzeigevorrichtung, umfassend:

eine OLED(organische Leuchtdioden)-Panel-einheit, die einen Eingang eines Videosignals und mehrere Antriebsleistungspegel für RGB-Farben empfängt und ein Bild anzeigt;
 eine Videosignalbereitstellungseinheit, die das Videosignal an die OLED-Paneleinheit bereitstellt; und
 eine Leistungsversorgungseinheit, die die mehreren Antriebsleistungspegel zu der OLED-Paneleinheit liefert, wobei die Leistungsversorgungseinheit funktionsfähig ist, Antriebsströme für die RGB-Farben, die zu der OLED-Paneleinheit zu liefern sind, basierend auf Luminanzinformationen des Videosignals vorherzusagen und eine Vorwärtskopplungssteuerung bezüglich der mehreren Antriebsleistungspegel basierend auf den vorhergesagten Antriebsströmen durchzuführen;
dadurch gekennzeichnet, dass:
 die Leistungsversorgungseinheit Folgendes umfasst:

eine Gleichrichtungseinheit, die dazu eingerichtet ist, eine externe AC-Leistung gleichzurichten;
 eine Leistungsfaktorkorrektur- bzw. PFC-Einheit, die dazu eingerichtet ist, zu veranlassen, dass sich die Spannung und der Strom der gleichgerichteten AC-Leistung in der gleichen Phase befinden, und die AC-Spannung in eine DC-Spannung zu transformieren;
 einen Wandler, der dazu eingerichtet ist, die DC-Spannung in mehrere Spannungen umzuwandeln, um die mehreren Spannungen über einen Mehrwicklunginsulations-transformator auszugeben;
 mehrere Ausgangsanschlüsse, die dazu eingerichtet sind, die mehreren Spannungen auszugeben;
 mehrere Schalteinheiten, die dazu eingerichtet sind, die mehreren Spannungen des Wandlers an die mehreren Ausgangsanschlüsse selektiv bereitzustellen; und
 eine Leistungssteuereinheit, die dazu eingerichtet ist, die mehreren Schalteinheiten zu steuern, eine Rückkopplungssteuerung bezüglich der mehreren Spannungen, die von der Ausgabeeinheit ausgegeben werden, durchzuführen, wobei jede der mehreren Schalteinheiten Folgendes umfasst:

ein Schaltelement mit einem Ende, das mit dem Wandler verbunden ist;
 eine Induktivität mit einem ersten Ende, das mit dem anderen Ende des Schaltelements verbunden ist, und einem zweiten Ende, das mit einem der meh-

- reren Ausgangsanschlüsse verbunden ist; und
 eine Diode mit einer Anode, die gemeinsam mit dem anderen Ende des Schaltelements und dem ersten Ende der Induktivität verbunden ist, und auch mit einer Kathode, die mit Masse verbunden ist.
2. Anzeigevorrichtung nach Anspruch 1, wobei die OLED-Paneleinheit mehrere Pixel beinhaltet, die in mehrere Pixelgruppen für die RGB-Farben klassifiziert und in einer Matrixform angeordnet sind, und die mehreren Pixelgruppen jeweils separate Antriebsleistungspegel empfangen.
3. Anzeigevorrichtung nach Anspruch 1 oder 2, wobei der Wandler ein diskreter LLC-Wandler ist.
4. Anzeigevorrichtung nach einem vorangegangenen Anspruch, wobei die Luminanzinformationen Informationen über Lichtemittierungspegel für die RGB-Farben der OLED-Paneleinheit und Timing-Informationen, zu denen die Lichtemittierungspegel angelegt werden, beinhalten.
5. Leistungsversorgungsverfahren einer Leistungsversorgungseinrichtung, die mehrere Antriebsleistungspegel für RGB-Farben an eine OLED(organi-sche Leuchtdioden)-Paneleinheit bereitstellt, wobei das Verfahren Folgendes umfasst:
- Bereitstellen des Videosignals an die OLED-Paneleinheit;
 Vorhersagen von Antriebsströmen für die RGB-Farben, die zu der OLED-Paneleinheit zu liefern sind, basierend auf Luminanzinformationen des Videosignals und Durchführen einer Vorwärtskopplungssteuerung bezüglich der mehreren Antriebsleistungspegel basierend auf den vorhergesagten Antriebsströmen;
 Gleichrichten einer externen AC-Leistung;
 Veranlassen, dass sich die Spannung und der Strom der gleichgerichteten AC-Leistung in der gleichen Phase befinden, und Transformieren der AC-Spannung in eine DC-Spannung;
 Umwandeln der DC-Spannung in mehrere Spannungen, um die mehreren Spannungen über einen Mehrwicklungsinsulationstransformator auszugeben;
 selektives Ausgeben der mehreren Spannungen über mehrere Ausgangsanschlüsse; und
 Steuern der mehreren Schalteinheiten, eine Rückwärtskopplungssteuerung bezüglich der mehreren Spannungen, die von der Ausgabereinheit ausgegeben werden, durchzuführen, wobei jede der mehreren Schalteinheiten Folgendes umfasst:
- ein Schaltelement mit einem Ende, das mit dem Wandler verbunden ist;
 eine Induktivität mit einem ersten Ende, das mit dem anderen Ende des Schaltelements verbunden ist, und einem zweiten Ende, das mit einem der mehreren Ausgangsanschlüsse verbunden ist; und
 eine Diode mit einer Anode, die gemeinsam mit dem anderen Ende des Schaltelements und dem ersten Ende der Induktivität verbunden ist, und auch mit einer Kathode, die mit Masse verbunden ist.
6. Leistungsversorgungsverfahren nach Anspruch 5, wobei der Umwandelungsschritt die DC-Spannung in die mehreren Antriebsleistungspegel mit unterschiedlichen Spannungspegeln für die RGB-Farben umwandelt.
7. Leistungsversorgungsverfahren nach Anspruch 5 oder 6, wobei die Luminanzinformationen Informationen über Lichtemittierungspegel für die RGB-Farben der OLED-Paneleinheit und Timing-Informationen, zu denen die Lichtemittierungspegel angelegt werden, beinhalten.

Revendications

1. Appareil d'affichage comprenant :
- une unité de panneau à DELO (diode électroluminescente organique) recevant une entrée d'un signal vidéo et une pluralité de niveaux de puissance de pilotage pour des couleurs RVB et affichant une image ;
 une unité de fourniture de signal vidéo fournissant le signal vidéo à l'unité de panneau à DELO ; et
 une unité d'alimentation en puissance fournissant la pluralité de niveaux de puissance de pilotage à l'unité de panneau à DELO, dans lequel l'unité d'alimentation en puissance peut prédire des courants de pilotage pour les couleurs RVB à fournir à l'unité de panneau à DELO d'après des informations de luminance du signal vidéo et réaliser une commande à action directe par rapport à la pluralité de niveaux de puissance de pilotage d'après les courants de pilotage prédits ; **caractérisé en ce que** :
 l'unité d'alimentation en puissance comprend :
- une unité de redressement conçue pour redresser une puissance alternative externe ;
 une unité de correction de facteur de puissance, PFC, conçue pour amener une tension et un courant de la puissance alternative redressée à être dans la même phase

- et pour transformer la tension alternative en une tension continue ;
 un convertisseur conçu pour convertir la tension continue en une pluralité de tensions pour fournir en sortie la pluralité de tensions par l'intermédiaire d'un transformateur d'isolement à enroulements multiples ;
 une pluralité de bornes de sortie conçues pour fournir en sortie la pluralité de tensions ;
 une pluralité d'unités de commutation conçues pour fournir sélectivement la pluralité de tensions du convertisseur à la pluralité de bornes de sortie ; et
 une unité de commande de puissance conçue pour commander la pluralité d'unités de commutation pour réaliser une commande à rétroaction par rapport à la pluralité de tensions fournies en sortie depuis l'unité de sortie, dans lequel chacune de la pluralité d'unités de commutation comprend :
- un élément de commutation ayant une extrémité connectée au convertisseur ;
 une bobine d'induction ayant une première extrémité connectée à l'autre extrémité de l'élément de commutation et une seconde extrémité connectée à l'une de la pluralité de bornes de sortie ;
 et
 une diode ayant une anode généralement connectée à l'autre extrémité de l'élément de commutation et à la première extrémité de la bobine d'induction et ayant également une cathode mise à la terre.
2. Appareil d'affichage selon la revendication 1, dans lequel l'unité de panneau à DELO comporte une pluralité de pixels qui sont classés en une pluralité de groupes de pixels pour les couleurs RVB et agencés sous forme de matrice, et la pluralité de groupes de pixels reçoit des niveaux de puissance de pilotage séparés, respectivement.
3. Appareil d'affichage selon la revendication 1 ou 2, dans lequel le convertisseur est un convertisseur LLC discret.
4. Appareil d'affichage selon l'une quelconque des revendications précédentes, dans lequel les informations de luminance comportent des informations sur des niveaux d'émission de lumière pour les couleurs RVB de l'unité de panneau à DELO et des informations de moment auxquelles les niveaux d'émission de lumière sont appliqués.
5. Procédé d'alimentation en puissance d'un dispositif d'alimentation en puissance fournissant une pluralité de niveaux de puissance de pilotage pour des couleurs RVB à une unité de panneau à DELO (diode électroluminescente organique), le procédé comprenant :
- la fourniture du signal vidéo à l'unité de panneau à DELO ;
 la prédiction de courants de pilotage pour les couleurs RVB à fournir à l'unité de panneau à DELO d'après des informations de luminance du signal vidéo et la réalisation d'une commande à action directe par rapport à la pluralité de niveaux de puissance de pilotage d'après les courants de pilotage prédits ;
 le redressement d'une puissance alternative externe ;
 le fait d'amener une tension et un courant de la puissance alternative redressée à être dans la même phase et à transformer la tension alternative en une tension continue ;
 la conversion de la tension continue en une pluralité de tensions pour fournir en sortie la pluralité de tensions par l'intermédiaire d'un transformateur d'isolement à enroulements multiples ;
 la fourniture en sortie sélective de la pluralité de tensions via une pluralité de bornes de sortie ; et
 la commande de la pluralité d'unités de commutation pour réaliser une commande à rétroaction par rapport à la pluralité de tensions fournies en sortie depuis l'unité de sortie, dans lequel chacune de la pluralité d'unités de commutation comprend :
- un élément de commutation ayant une extrémité connectée au convertisseur ;
 une bobine d'induction ayant une première extrémité connectée à l'autre extrémité de l'élément de commutation et une seconde extrémité connectée à l'une de la pluralité de bornes de sortie ; et
 une diode ayant une anode généralement connectée à l'autre extrémité de l'élément de commutation et à la première extrémité de la bobine d'induction et ayant également une cathode mise à la terre.
6. Procédé d'alimentation en puissance selon la revendication 5, dans lequel l'étape de conversion convertit la tension continue en la pluralité de niveaux de puissance de pilotage ayant des niveaux de tension différents pour les couleurs RVB.
7. Procédé d'alimentation en puissance selon la revendication 5 ou 6, dans lequel les informations de luminance comportent des informations sur des niveaux d'émission de lumière pour les couleurs RVB

de l'unité de panneau à DELO et des informations de moment auxquelles les niveaux d'émission de lumière sont appliqués.

5

10

15

20

25

30

35

40

45

50

55

10

FIG. 1

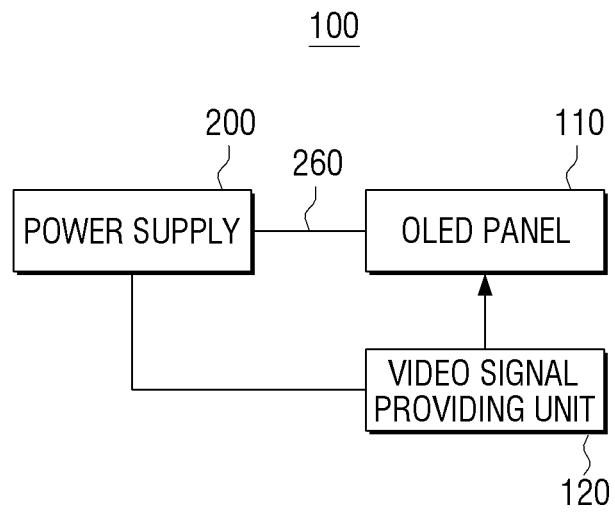

FIG. 2

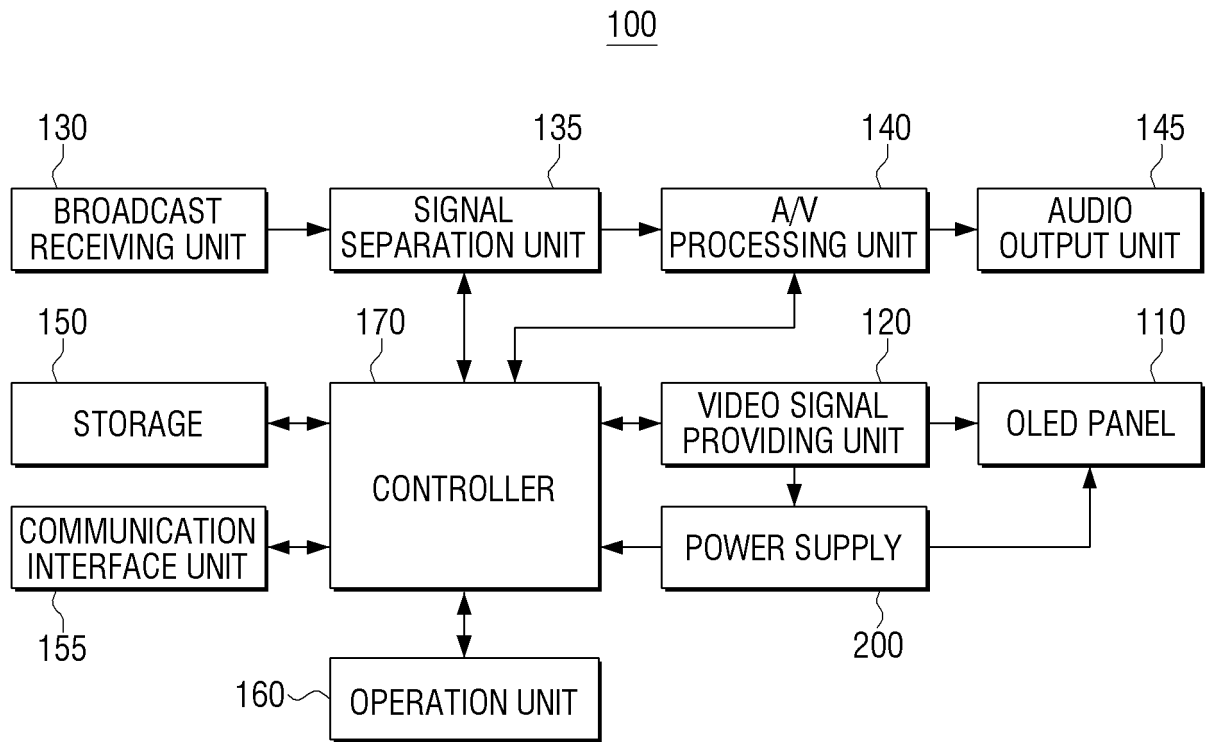

FIG. 3

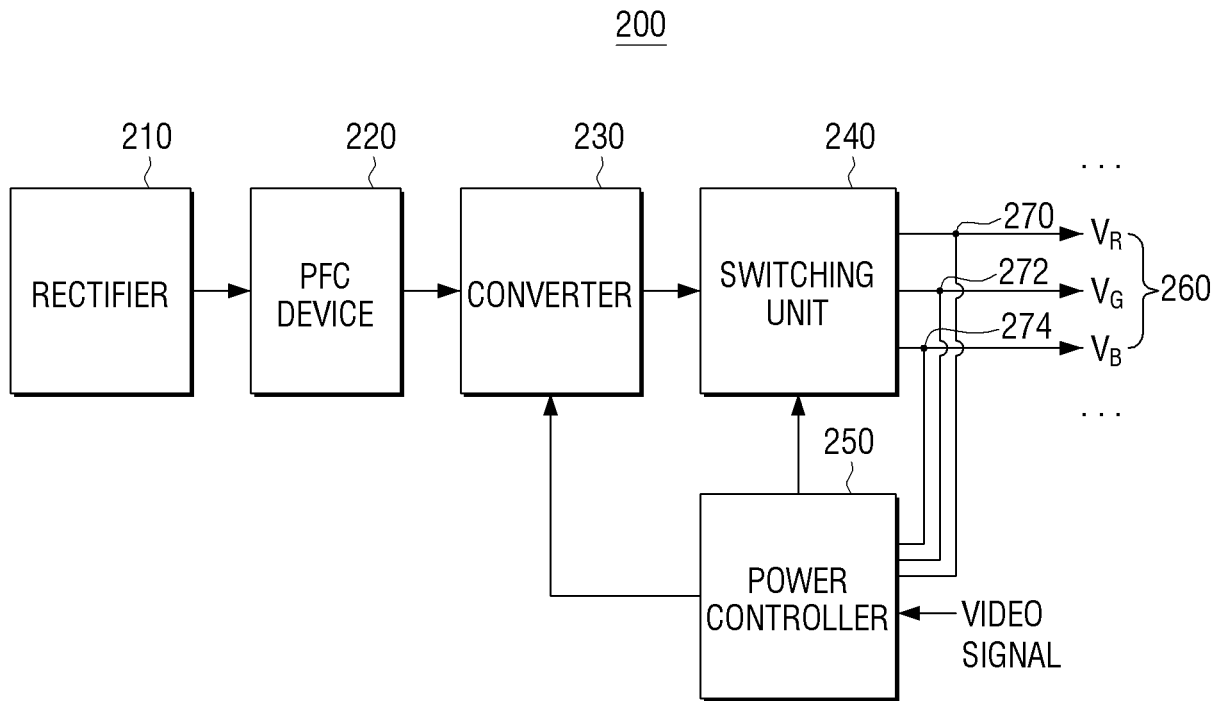

FIG. 4

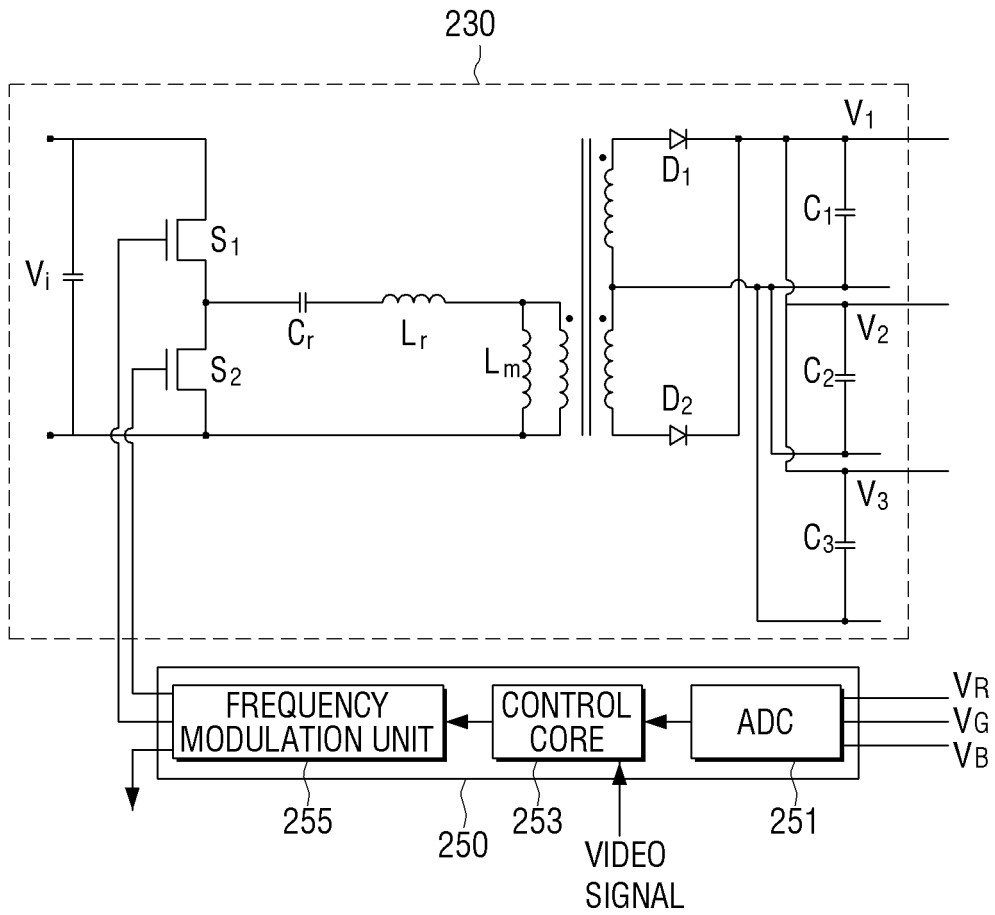

FIG. 5

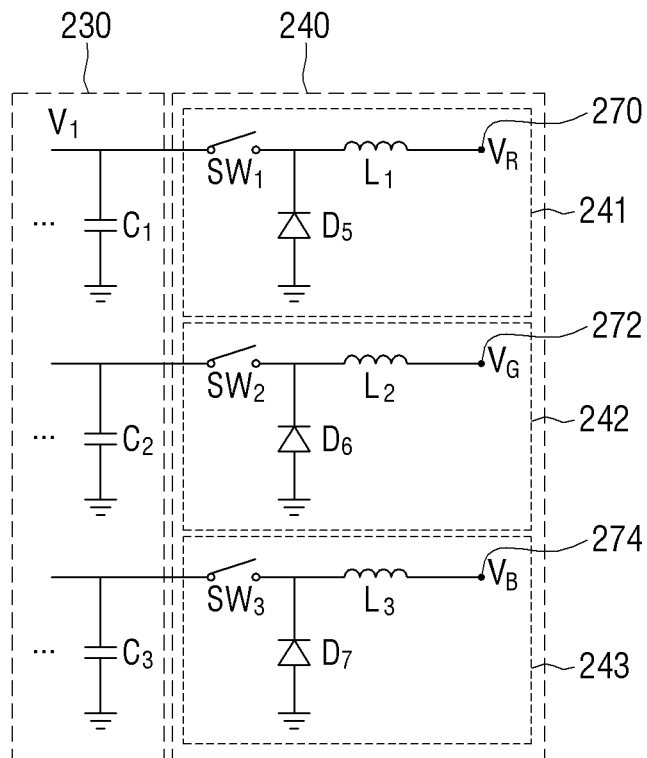

FIG. 6

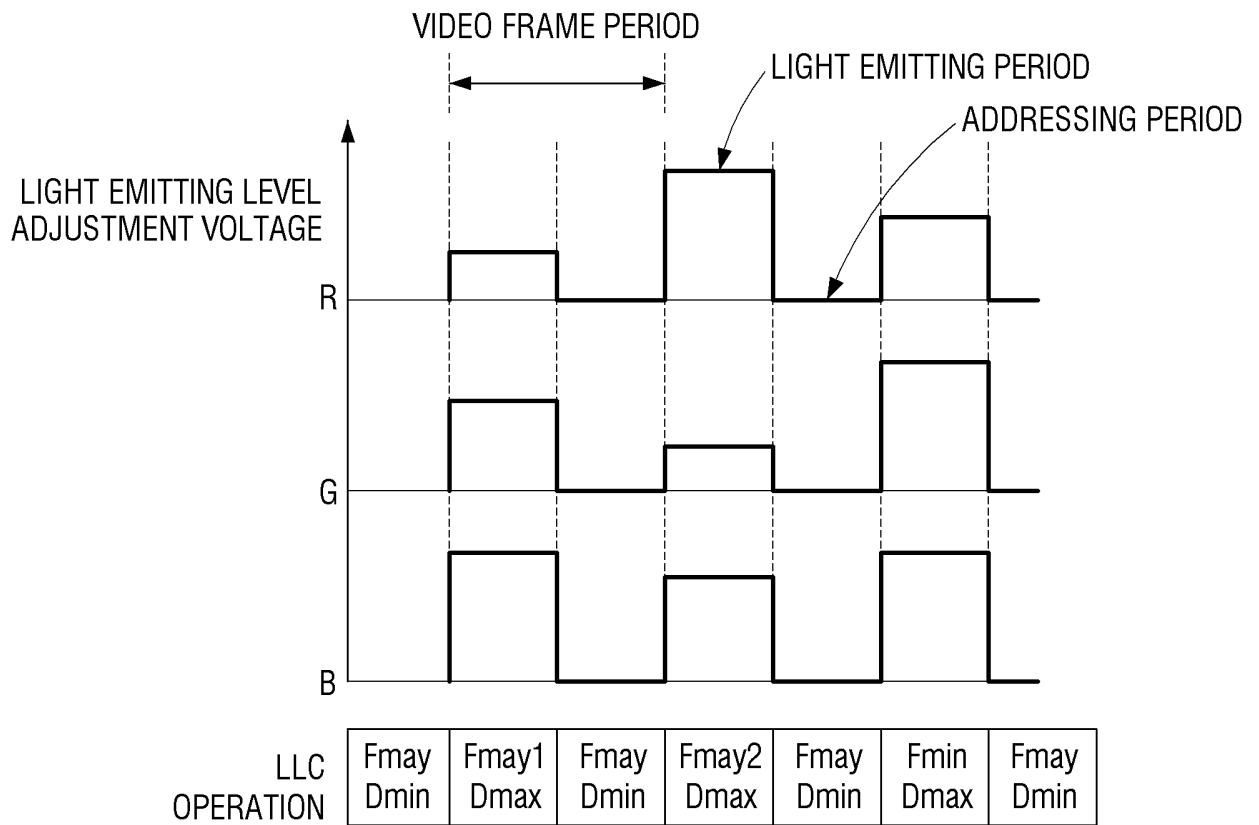

FIG. 7

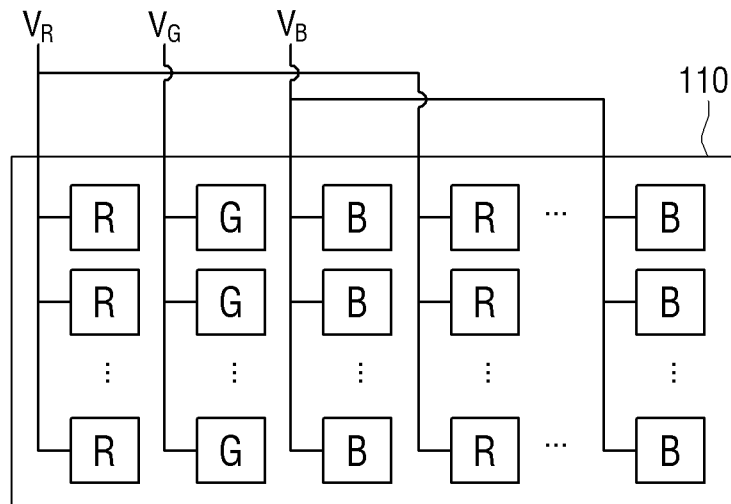
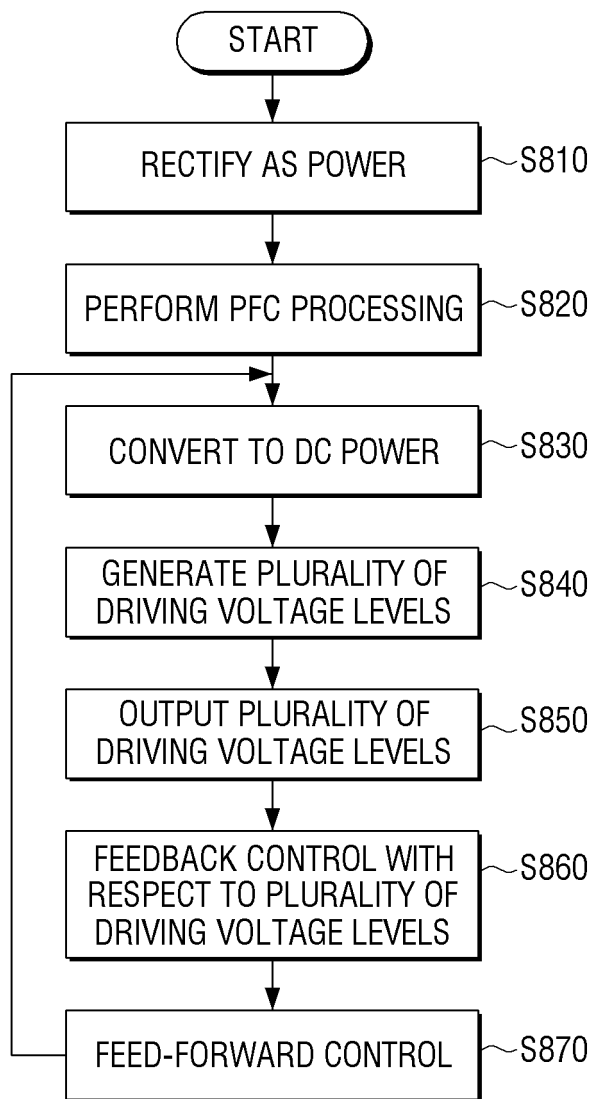

FIG. 8



REFERENCES CITED IN THE DESCRIPTION

This list of references cited by the applicant is for the reader's convenience only. It does not form part of the European patent document. Even though great care has been taken in compiling the references, errors or omissions cannot be excluded and the EPO disclaims all liability in this regard.

Patent documents cited in the description

- US 201184992 B [0004]
- US 2002070914 A [0005]

专利名称(译)	电源装置，具有该电源装置的显示装置和电源方法		
公开(公告)号	EP2610843B1	公开(公告)日	2019-04-03
申请号	EP2012188203	申请日	2012-10-11
[标]申请(专利权)人(译)	三星电子株式会社		
申请(专利权)人(译)	SAMSUNG ELECTRONICS CO. , LTD.		
当前申请(专利权)人(译)	SAMSUNG ELECTRONICS CO. , LTD.		
[标]发明人	HYEON BYEONG CHEOL YI KANG HYUN		
发明人	HYEON, BYEONG-CHEOL YI, KANG-HYUN		
IPC分类号	G09G3/32		
CPC分类号	G09G3/3208 G09G2320/0223 G09G2320/0242 G09G2320/0666 G09G2330/02 G09G2330/021 G09G2330/028 G09G2360/16		
优先权	1020110144994 2011-12-28 KR		
其他公开文献	EP2610843A2 EP2610843A3		
外部链接	Espacenet		

摘要(译)

一种显示装置，包括：OLED面板，接收视频信号的输入和用于RGB颜色的多个驱动功率电平并显示图像；视频信号提供单元，将视频信号提供给OLED面板；以及电源，供应多个驱动功率电平到OLED面板单元并对多个驱动功率电平中的每一个执行单独的反馈控制。

FIG. 1

