



(11) **EP 1 560 193 B1**

(12) **EUROPEAN PATENT SPECIFICATION**

(45) Date of publication and mention of the grant of the patent:
12.09.2007 Bulletin 2007/37

(51) Int Cl.:
G09G 3/32^(2006.01) H01L 27/00^(2006.01)

(21) Application number: **04078425.8**

(22) Date of filing: **15.12.2004**

(54) **Organic electroluminescent display device**

Organische elektrolumineszente Anzeigevorrichtung

Dispositif d'affichage électroluminescent organique

(84) Designated Contracting States:
AT BE BG CH CY CZ DE DK EE ES FI FR GB GR HU IE IS IT LI LT LU MC NL PL PT RO SE SI SK TR

(30) Priority: **05.01.2004 KR 2004000434**

(43) Date of publication of application:
03.08.2005 Bulletin 2005/31

(73) Proprietor: **Samsung SDI Co., Ltd.**
Suwon-si,
Gyeonggi-do (KR)

(72) Inventors:
• **Kwak, Won-Kyu**
Legal & IP Team Corporate Planning
Giheung-eup
Yongin-si
Gyeonggi-do (KR)

• **Kim, Kyong-Do**
Legal & IP Team Corporate Planning
Giheung-eup
Yongin-si
Gyeonggi-do (KR)

(74) Representative: **Hengelhaupt, Jürgen et al**
Anwaltskanzlei
Gulde Hengelhaupt Ziebig & Schneider
Wallstrasse 58/59
10179 Berlin (DE)

(56) References cited:
US-A1- 2002 140 646 US-A1- 2003 146 693

EP 1 560 193 B1

Note: Within nine months from the publication of the mention of the grant of the European patent, any person may give notice to the European Patent Office of opposition to the European patent granted. Notice of opposition shall be filed in a written reasoned statement. It shall not be deemed to have been filed until the opposition fee has been paid. (Art. 99(1) European Patent Convention).

Description**BACKGROUND OF THE INVENTION****Field of the Invention**

[0001] The present invention relates to an organic electro luminescence display and, more particularly, to an organic electro luminescence display in which a cathode power line is connected with a cathode electrode by a plurality of contact holes.

Description of the Related Art

[0002] Typically, organic electro luminescence displays are self-emissive displays that are classified, according to the direction of light emitted from their organic emission layer, as either bottom-emitting types, top-emitting types, or dual-emitting types. The top-emitting type emits light in a direction away from the substrate on which the pixels are arranged, while the bottom-emitting type emits light toward the substrate on which the pixels are arranged. Top-emitting types have a higher aperture ratio than bottom-emitting types.

[0003] In the top-emitting type, because the light is emitted from the organic emission layer away from the substrate on which the pixels are arranged, one of the electrodes between which the organic emission layer is interposed should be transparent so that light may be transmitted through it. Typically, the transparent electrode is made of transparent conductive material such as Indium Tin Oxide (ITO). Transparent conductive material has a high resistance value, however, which causes a voltage (IR) drop, thereby creating an inconsistent brightness on the display.

[0004] To solve this problem, a technology has been proposed that uses a metallic material as a cathode power line for supplying a cathode voltage to a transparent cathode electrode, which is one of the two electrodes formed on the upper and lower portions of the organic emission layer.

[0005] FIG. 1 shows a plan view of a conventional organic electro luminescence display with a cathode power line.

[0006] Referring to FIG. 1, a conventional organic electro luminescence display 100 comprises a pixel portion 110 on which a plurality of pixels are arranged, an upper power line 120 on the top, right and left sides of the pixel portion 110 to supply the power supply voltage VDD, a lower power line 130 on the bottom side of the pixel portion 110 to supply the power supply voltage VDD, a scan driver 140 that supplies a scan signal sequentially to pixels of the pixel portion 110, a data driver 150 that supplies a data signal to pixels of the pixel portion 110, and a cathode electrode 160, which is formed to cover all of the pixel portion 110.

[0007] The conventional organic electro luminescence display 100 further comprises an external terminal 171,

which is used to apply an external voltage to the cathode power line 170. As shown in FIGs. 1 and 2, the cathode power line 170 is connected with the cathode electrode 160 by contact hole 180, thereby connecting the cathode electrode 160 to the external voltage supplied at the external terminal 171.

[0008] With this configuration, the conventional organic electro luminescence operates as follows.

[0009] The scan driver 140 signal and the data driver 150 signal are transmitted to the pixels in the pixel portion 110. A predetermined level of power supply voltage VDD is supplied from the upper and lower power lines 120, 130 to the pixels in the pixel portion 110, and the cathode voltage is supplied from the cathode power line 170 to the cathode electrode 160 via the contact hole 180. Switching and driving transistors (not shown) provided in each of the pixels arranged in the pixel portion 110 then operate, so that light is emitted from the organic emission layer and transmitted through the cathode electrode 160.

[0010] During this operation, the electric current flowing through the cathode power line 170 is concentrated on the edge of the contact hole 180, so that current density is highest at the edge of the contact hole 180. Equipotential lines within the contact hole 180, as shown in FIG. 2, show that the current mobility decreases from the edge to the center of the contact hole 180, and the current is lowest at the center of the contact hole 180.

[0011] Hence, the larger the contact hole 180 is, the more its circumference or perimeter is lengthened, thereby concentrating the current density on its edge. This results in a decrease of current mobility from the edge to the center of the contact hole 180, which in turn results in a voltage (IR) drop and decreases brightness in the display.

[0012] Furthermore US 2002/140646 discloses a display module in which an electrode layer is in contact with a second electrode layer through contact holes and US 2003/146693 discloses an organic light emitting device, the organic light emitting device comprising a second electrode per pixel, the second electrode being connected to the second power supply line in the region of each pixel through a plurality of contact holes. However, none of the prior art documents discloses the concentration of the current density on the edge of a contact hole(s) is prevented.

SUMMARY OF THE INVENTION

[0013] Accordingly, the present invention is directed to an organic electro luminescence display that substantially obviates one or more of the problems due to limitations and disadvantages of the related art.

[0014] The present invention provides an organic electro luminescence display in which current mobility is increased by connecting a cathode power line to a cathode electrode via a plurality of contact holes, as claimed in the appended claims.

[0015] It is to be understood that both the foregoing general description and the following detailed description are exemplary and explanatory and are intended to provide further explanation of the invention as claimed.

BRIEF DESCRIPTION OF THE DRAWINGS

[0016] The accompanying drawings, which are included to provide a further understanding of the invention and are incorporated in and constitute a part of this specification, illustrate embodiments of the invention and together with the description serve to explain the principles of the invention.

[0017] FIG. 1 shows a plan view of a conventional organic electro luminescence display.

[0018] FIG. 2 shows a plan view of the cathode power line connected with the cathode electrode by a contact hole in the conventional organic electro luminescence display of FIG. 1.

[0019] FIG. 3 shows a plan view of a cathode power line connected with a cathode electrode by a plurality of contact holes in an organic electro luminescence display according to a first exemplary embodiment of the present invention.

[0020] FIG. 4 shows a plan view of a cathode power line connected with a cathode electrode by a plurality of contact holes in an organic electro luminescence display according to a second exemplary embodiment of the present invention.

[0021] FIG. 5 shows a plan view of a cathode power line connected with a cathode electrode by a plurality of contact holes in an organic electro luminescence display according to a third exemplary embodiment of the present invention.

[0022] FIG. 6 shows a plan view of a cathode power line in an organic electro luminescence display according to a fourth exemplary embodiment of the present invention.

DETAILED DESCRIPTION OF THE ILLUSTRATED EMBODIMENTS

[0023] Reference will now be made in detail to embodiments of the present invention, examples of which are illustrated in the accompanying drawings.

[0024] FIG. 3 shows a plan view of a cathode power line connected with a cathode electrode by a plurality of contact holes in an organic electro luminescence display according to a first exemplary embodiment of the present invention. Since the first exemplary embodiment of the present invention is the same as the organic electro luminescence display illustrated in FIG. 1 except for the structure of the cathode power line and the contact holes, only the cathode power line and the contact holes are illustrated in FIG. 3.

[0025] An organic electro luminescence display according to the first exemplary embodiment of the present invention comprises a pixel portion on which a plurality

of pixels are arranged; an upper power line on the top, right and left sides of the pixel portion to supply the power supply voltage VDD; a lower power line on the bottom side of the pixel portion to supply the power supply voltage VDD; a scan driver that supplies a scan signal sequentially to the pixels of the pixel portion; a data driver that supplies a data signal to the pixels of the pixel portion; a cathode electrode that is formed to cover all of the pixel portion; and a cathode power line that is overlapping the cathode electrode and supplies a cathode voltage from an external terminal to the cathode electrode.

[0026] Referring to FIG. 3, the cathode power line 270 is electrically connected with the cathode electrode by a plurality of contact holes 280, which are formed in an interposed insulating layer (not shown).

[0027] The contact holes 280 are arranged in a matrix comprised of rows and columns in the region where the cathode power line 270 is overlapping the cathode electrode, so that each row and each column has the same number of contact holes. Further, all contact holes 280 are congruent, and they are arranged to have the same distance between each other in the row and column direction, although the distance between adjacent holes in the row direction need not be the same as the distance between adjacent holes in the column direction. According to the first exemplary embodiment of the present invention as shown in FIG. 3, the contact hole 280 has a square shape, but the contact hole 280 may have any other shape including rectangular, circular, elliptical, and polygonal.

[0028] As compared with the circumference or perimeter of a single contact hole like the conventional contact hole 180 of FIG. 1, the total circumference or perimeter of the plurality of contact holes 280 according to the first exemplary embodiment as shown in FIG. 3 is as determined below.

[0029] Let the lengths of each contact hole 280 be "z" and "t", in the row and column directions, respectively, and the distance between the adjacent contact holes 280 be "s" and "w", in the row and column directions, respectively. Therefore, the area of each contact hole 280 is "z × t", and the perimeter of each contact hole 280 is "2(z + t)". If "n" is the total number of contact holes 280 in the region where the cathode power line 270 is overlapping the cathode electrode, then the total area of all contact holes 280 is "n(z × t)" and the total perimeter of all contact holes 280 is "2n(z + t)".

[0030] On the other hand, if a single, maximized contact hole is formed in the region where the cathode power line is overlapping the cathode electrode, the lengths of the maximized contact hole would be "A" and "L" in the row and column directions, respectively. Therefore, the area of the maximized contact hole is "A × L", and its perimeter is "2(A + L)".

[0031] Hence, in the case of this exemplary embodiment, the voltage (IR) drop can be prevented by arranging the plurality of contact holes to satisfy the following two conditions:

$$(1) L \times A > n(z \times t)$$

$$(2) 2n(z \times t) > 2(A + L)$$

[0032] In this exemplary embodiment, the distances "s" and "w" between each adjacent contact hole 280 should be less than or equal to either one of the lengths "z" or "t" of each contact hole 280. Alternatively, the distances "s" and "w" between each adjacent contact hole 280 should be less than or equal to the smaller one of "z" and "t".

[0033] When conditions (1) and (2) noted above are met, the total perimeter of the plurality of contact holes is greater than the perimeter of the region where the cathode power line is overlapping the cathode electrode, thereby increasing the current mobility and preventing the voltage (IR) drop.

[0034] In other words, as shown in FIG.3, along the equipotential lines, the current density is higher near the edge of each contact hole 280 and is lower near the center of each contact hole 280. Therefore, the center of each contact hole 280 is the point at which the current density is lowest. However, as shown in this first exemplary embodiment, when the plurality of contact holes are formed to have a total perimeter greater than the perimeter of the region where the cathode power line is overlapping the cathode electrode, there are formed a plurality of regions having the high current density of an equivalent level along the equipotential lines in the edge of the each contact hole 280. This increases current mobility.

[0035] Thus, according to the first exemplary embodiment of the present invention, a plurality of contact holes 280 formed within an organic electro luminescence display can reduce the voltage (IR) drop by increasing the current mobility, thereby preventing a decrease in the brightness of the display.

[0036] FIG. 4 shows a plan view of a cathode power line connected with a cathode electrode by a plurality of contact holes in an organic electro luminescence display according to a second exemplary embodiment of the present invention. Since the second exemplary embodiment of the present invention is the same as the organic electro luminescence display illustrated in FIG. 1 except for the structure of the cathode power line and the contact holes, only the cathode power line and the contact holes are illustrated in FIG. 4.

[0037] Referring to FIG. 4, the cathode power line 270 is electrically coupled to the cathode electrode by a plurality of contact holes 280, which are formed in an interposed insulating layer (not shown).

[0038] The contact holes 280 are arranged in a matrix comprised of rows and columns in the region where the cathode power line 270 is overlapping the cathode electrode, so that each row and each column has the same

number of contact holes. Further, all contact holes 280 are congruent, and they are arranged to have the same distance between each other in the row and column direction, although the distance between adjacent holes in the row and column direction need not be the same as the distance between adjacent holes in the column direction. According to the second exemplary embodiment of the present invention as shown in FIG. 4, the contact hole 280 has a circular shape, but the contact hole 280 may have any other shape including rectangular, square, elliptical, and polygonal.

[0039] As compared with the perimeter of a single contact hole like the conventional contact hole 180 of FIG. 1, the total circumference of the plurality of contact holes 280 according to the second exemplary embodiment as shown in FIG.4 is as follows.

[0040] Let the radius of each contact hole 280 be "r", and the distances between the adjacent contact holes 280 be "s" and "w" in the row and column directions, respectively. Therefore, the area of each contact hole 280 is " πr^2 ", and the circumference of each contact hole 280 is " $2\pi r$ ". If "n" is the total number of contact holes 280 in the region where the cathode power line 270 is overlapping the cathode electrode, then the total area of all contact holes 280 is " $n\pi r^2$ " and the total circumference of all contact holes 280 is " $2n\pi r$ ".

[0041] On the other hand, if a single, maximized contact hole is formed in the region where the cathode power line is overlapping the cathode electrode, the lengths of the maximized contact hole in the row and column directions are "A" and "L". Therefore, the area of the maximized contact hole is " $A \times L$ ", and its perimeter is " $2(A + L)$ ".

[0042] Hence, in the case of this exemplary embodiment, the voltage (IR) drop can be prevented by arranging the plurality of contact holes to satisfy the following conditions (3) and (4).

$$(3) L \times A > n\pi r^2$$

$$(4) 2n\pi r > 2(A+L)$$

[0043] In this exemplary embodiment, the distances "s" and "w" between each adjacent contact hole 280 should be less than or equal to the diameter (2r) of each contact hole 280.

[0044] When conditions (3) and (4) noted above are met, the total area of the plurality of contact holes is less than the area of the single contact hole of the conventional organic electro luminescence display, but the total circumference or perimeter of the plurality of contact holes is greater than the circumference or perimeter of the conventional single contact hole.

[0045] Thus, according to the second exemplary em-

bodiment of the present invention, because the current mobility is high in the circumferential edge of the contact holes 280, the whole current mobility increases thereby decreasing the voltage (IR) drop, which prevents a decrease in the brightness of the display.

[0046] FIG. 5 shows a plan view of a cathode power line connected with a cathode electrode by a plurality of contact holes in an organic electro luminescence display according to a third exemplary embodiment of the present invention. Since the third exemplary embodiment of the present invention is the same as the organic electro luminescence display illustrated in FIG. 1 except for the structure of the cathode power line and the contact holes, only the cathode power line and the contact holes are illustrated in FIG. 5.

[0047] Referring to FIG. 5, the cathode power line 270 is electrically coupled to the cathode electrode by a plurality of contact holes 280, which are formed in an interposed insulating layer (not shown).

[0048] The contact holes 280 are arranged as a single column in the region where the cathode power line 270 is overlapping the cathode electrode. Additionally, all contact holes 280 are congruent, and they are arranged to have the same distance between each adjacent contact hole 280. According to the third exemplary embodiment of the present invention as shown in FIG. 5, the contact hole 280 has a rectangular shape, but the contact hole 280 may have any other shape including circular, square, elliptical, and polygonal.

[0049] According to this third exemplary embodiment, the contact holes 280 are formed so that the foregoing conditions (1) and (2) are satisfied. When the foregoing conditions (1) and (2) are satisfied, the total perimeter of the plurality of contact holes is greater than the perimeter of the region of the cathode power line that is overlapping the cathode electrode, thereby increasing the current mobility and preventing the voltage (IR) drop. In this third exemplary embodiment, the distance "w" between the adjacent contact holes arranged in a single column should be equal to or less than the lengths of each contact hole in the column direction.

[0050] The exemplary embodiments shown in FIGs. 3, 4, and 5 show the contact holes in the insulating layer between the cathode power line and cathode electrode to be of the same size and shape, but they may be formed in different sizes and shapes. In other words, rectangular contact holes and circular contact holes may be formed together in the insulating layer. As with the exemplary embodiments shown in FIGs. 3, 4, and 5, however, the total circumference or perimeter of the different sized and shaped contact holes must be greater than the circumference or perimeter of the region where the cathode power line is overlapping cathode electrode.

[0051] FIG. 6 shows a plan view of an organic electro luminescence display according to a fourth exemplary embodiment of the present invention. Since the fourth exemplary embodiment of the present invention is the same as the organic electro luminescence display illus-

trated in FIG. 1 except for the structure of the cathode power line and the contact holes, only a connection portion of the cathode power line is illustrated in FIG. 6. Contact holes are not illustrated in FIG. 6.

[0052] Referring to FIG. 6, the organic electro luminescence display according to a fourth embodiment of the present invention comprises a cathode power line 570 overlapped with, and supplying a cathode voltage to, a cathode electrode 560, and cathode auxiliary power lines 571, 572, 573, and 574 to supply the voltage applied at the external terminal 550 to the cathode power line 570.

[0053] When cathode voltage is applied at the external terminal 550, the cathode voltage is supplied to four sides of the cathode power line 570 through the cathode auxiliary power lines 571, 572, 573, and 574. The cathode voltage is, in turn, supplied from the cathode power line 570 to the cathode electrode 560 via a plurality of contact holes as exemplified in the first, second, and third exemplary embodiments.

[0054] In the organic electro luminescence display according to the fourth exemplary embodiment shown in FIG. 6, the cathode voltage is supplied from the external terminal 550 to four sides of the cathode power line 570 through the cathode auxiliary power lines 571, 572, 573, and 574. On the other hand, in the first through third exemplary embodiments, the cathode voltage is supplied from the external terminal to one side of the cathode power line. As a result of utilizing cathode auxiliary power lines 571, 572, 573, and 574, the voltage (IR) drop in the cathode power line decreases, which enhances the brightness of the display.

[0055] In the fourth exemplary embodiment, the cathode voltage is supplied from one external terminal 550 to four sides of the cathode power line 570 through the cathode auxiliary power lines 571, 572, 573, and 574, but it may also be supplied from a plurality of external terminals 550 to four sides of the cathode power line 570 through the cathode auxiliary power lines 571, 572, 573, and 574, respectively. Further, the cathode voltage may be supplied through the respective cathode auxiliary power lines to two or three sides, as well as four sides of the cathode power line. Moreover, a plurality of cathode auxiliary lines may also be arranged on one, two, or three sides of the cathode power line, and thus the cathode voltage can be supplied from one or more external terminals to one or more positions on one or more sides of the cathode power line. In the organic electro luminescence display of the fourth exemplary embodiment, the cathode power line 570 may include a plurality of contact holes having the same structure as the contact holes as exemplified in the first, second, and third exemplary embodiments.

[0056] In the illustrated exemplary embodiments, the cathode power line is provided at one side of the pixel portion, and it is connected with the cathode electrode via contact holes. However, at least one cathode power line may be provided on the top, bottom, left and right sides of the pixel portion. Further, in the illustrated ex-

emplary embodiments, the contact holes for connecting the cathode power line with the cathode electrode were rectangular, including a square, and circular. But the contact holes may have any other shape including elliptical and polygonal.

[0057] As described above in the exemplary embodiments, the organic electro luminescence display according to the present invention compensates for the voltage (IR) drop by utilizing a cathode power line connected to a cathode electrode via a plurality of contact holes and by supplying a cathode voltage from the external terminal to the cathode power line via cathode auxiliary power lines.

[0058] It will be apparent to those skilled in the art that various modifications and variation can be made in the present invention without departing from the scope of the invention. Thus, it is intended that the present invention cover the modifications and variations of this invention provided they come within the scope of the appended claims and their equivalents.

Claims

1. An organic electro luminescence display, comprising:

a pixel portion on which a plurality of pixels are arranged with a first pixel electrode, a second electrode, and an organic thin film layer interposed between the first and second electrodes; a first power line supplying a first level voltage to the first pixel electrodes of the pixel portion; a second power line having at least a region overlapping the second electrode to supply a second level voltage to the second electrode; and
 an insulating layer having a plurality of contact holes in the region where the second power line is overlapping the second electrode,
characterized in that the sum of circumferences or perimeters of each contact hole is greater than the circumference or perimeter of the overlapping region.

2. The organic electro luminescence display of claim 1, wherein a plurality of lowest current points having an equivalent level exist on the region in which the second power line is overlapping the second electrode.
3. The organic electro luminescence display of claim 1, wherein all contact holes are rectangular or square.
4. The organic electro luminescence display of claim 3, wherein the distance between adjacent contact holes in the row and column directions is equal to or

less than at least one of the lengths of each contact hole in the row and column directions.

5. The organic electro luminescence display of claim 3, wherein the distance between adjacent contact holes in the row and column directions is equal to or less than the smallest length of each contact hole in the row and column directions.
6. The organic electro luminescence display of claim 1, wherein all contact holes are circular or elliptical.
7. The organic electro luminescence display of claim 6, wherein, when the contact hole has a circular shape, the distance between adjacent contact holes is equal to or less than the diameter of the contact hole.
8. The organic electro luminescence display of claim 1, wherein the second level voltage is supplied to at least one position on at least one side of the second power line.
9. The organic electro luminescence display of claim 1, wherein the plurality of contact holes are congruent, and adjacent contact holes are equally spaced from each other.
10. An organic electro luminescence display, comprising:
 a pixel portion on which a plurality of pixels are arranged with a first pixel electrode, a second electrode, and an organic thin film layer interposed between the first electrode and the second electrode;
 a first power line supplying a first level voltage to the first pixel electrodes of the pixel portion;
 a second power line having at least a region overlapping the second electrode to supply a second level voltage to the second electrode,
 an insulating layer having a plurality of contact holes in the region where the second power line is overlapping the second electrode,
 wherein the second power line is arranged on at least one side of the pixel portion, and
characterized in that the second power line includes a plurality of auxiliary power lines to supply the second level voltage to the second electrode.
11. The organic electro luminescence display of claim 10, wherein a plurality of lowest current points having an equivalent level exist on the region in which the second power line is overlapping the second electrode.
12. The organic electro luminescence display of claim

- 10, wherein all contact holes are rectangular or square.
13. The organic electro luminescence display of claim 12, wherein the distance between the adjacent contact holes in the row and column directions is equal to or less than at least one of the lengths of each contact hole in the row and column directions.
14. The organic electro luminescence display as claimed in claim 12, wherein the distance between adjacent contact holes in the row and column directions is equal to or less than the smallest length of each contact hole in the row and column directions.
15. The organic electro luminescence display of claim 10, wherein all contact holes are circular or elliptical.
16. The organic electro luminescence display of claim 15, wherein, when the contact hole is circular, the distance between adjacent contact holes is equal to or less than the diameter of the contact hole.
17. The organic electro luminescence display of claim 10, wherein the auxiliary power lines are arranged to supply the second level voltage from at least two sides of the second power line to the second electrode.
18. The organic electro luminescence display of claim 17, wherein the auxiliary power lines are arranged to supply the second level voltage from at least one position of each side of the second power line to the second electrode.
19. The organic electro luminescence display of claim 10, wherein the plurality of contact holes are congruent, and adjacent contact holes are equally spaced from each other.
20. The organic electro luminescence display of claim 10, wherein the sum of the circumferences or perimeters of each contact hole is greater than the circumference or perimeter of the region in which the second power line and the second electrode overlap each other.
21. An organic electro luminescence display, comprising:
- a pixel portion on which a plurality of pixels are arranged with a first pixel electrode, a second electrode, and an organic thin film layer interposed between the first electrode and the second electrode;
 - a first power line supplying a first level voltage to the first pixel electrodes of the pixel portion;
 - a second power line having at least a region overlapping the second electrode to supply a second level voltage to the second electrode; and
 - an insulating layer having a plurality of contact holes in the region where the second power line is overlapping the second electrode, wherein the plurality of contact holes are arranged in a matrix of rows and columns and are coupling the second electrode to the second power line, and wherein the insulating layer includes at least two contact holes in the column direction and **characterized in that** all contact holes are circular or elliptical.
22. The organic electro luminescence display of claim 21, wherein the plurality of contact holes are congruent, and adjacent contact holes are equally spaced from each other.
23. The organic electro luminescence display of claim 22, wherein the distance between the adjacent contact holes in the row and column directions is equal to or less than at least one of the lengths of each contact hole in the row direction and the column directions.
24. The organic electro luminescence display of claim 22, wherein the distance between adjacent contact holes in the row and column directions is equal to or less than the smallest length of each contact hole in the row direction and the column direction.
25. The organic electro luminescence display of claim 21, wherein, when the contact hole is circular, the distance between adjacent contact holes is equal to or less than the diameter of the contact hole.
26. The organic electro luminescence display of claim 21, wherein the second level voltage is supplied to at least one position on at least one side of the second power line.
27. The organic electro luminescence display of claim 21, wherein sum of the circumferences of each contact hole is greater than the circumference of the region where the second power line and the second electrode overlap each other.
28. The organic electro luminescence display as claimed in claim 21, wherein a plurality of lowest current points having an equivalent level exist on the region in which the second power line is overlapping the second electrode.

Patentansprüche

1. Organische elektrolumineszente Anzeige, aufweisend:
- einen Pixelbereich, auf welchem eine Vielzahl von Pixeln angeordnet ist, wobei jeder Pixel eine erste Pixelelektrode, eine zweite Elektrode und einen organischen Dünnschichtfilm, welcher zwischen der ersten und zweiten Elektrode angeordnet ist, aufweist;
eine erste Spannungsleitung zur Versorgung der ersten Pixelelektroden des Pixelbereichs mit einer ersten Spannung;
eine zweite Spannungsleitung zur Versorgung der zweiten Elektrode mit einer zweiten Spannung, wobei die zweite Spannungsleitung mindestens eine Region, welche die zweite Elektrode überlappt, aufweist; und
eine Isolierschicht, welche eine Vielzahl von Kontaktlöchern in der Region, in der die zweite Spannungsleitung die zweite Elektrode überlappt, aufweist,
dadurch gekennzeichnet, dass die Summe der Umfänge jedes Kontaktlochs größer als der Umfang der überlappenden Region ist.
2. Organische elektrolumineszente Anzeige nach Anspruch 1, wobei eine Vielzahl von Punkten niedrigster Stromdichte in der Region, in welcher die zweite Spannungsleitung die zweite Elektrode überlappt, existiert, wobei alle diese Punkte die gleiche Stromdichte aufweisen.
3. Organische elektrolumineszente Anzeige nach Anspruch 1, wobei alle Kontaktlöcher rechteckig oder quadratisch sind.
4. Organische elektrolumineszente Anzeige nach Anspruch 3, wobei der Abstand zwischen benachbarten Kontaktlöchern in Zeilen- und Spaltenrichtung gleich mindestens einer der Längen jedes Kontaktlochs in Zeilen- und Spaltenrichtung oder kleiner als mindestens eine der Längen jedes Kontaktlochs in Zeilen- und Spaltenrichtung ist.
5. Organische elektrolumineszente Anzeige nach Anspruch 3, wobei der Abstand zwischen benachbarten Kontaktlöchern in Zeilen- und Spaltenrichtung gleich der kleinsten Länge jedes Kontaktlochs in Zeilen- und Spaltenrichtung oder kleiner als die kleinste Länge jedes Kontaktlochs in Zeilen- und Spaltenrichtung ist.
6. Organische elektrolumineszente Anzeige nach Anspruch 1, wobei alle Kontaktlöcher kreisförmig oder elliptisch sind.
7. Organische elektrolumineszente Anzeige nach Anspruch 6, wobei der Abstand zwischen benachbarten Kontaktlöchern gleich dem Durchmesser des Kontaktlochs oder kleiner als der Durchmesser des Kontaktlochs ist, wenn das Kontaktloch eine Kreisform aufweist.
8. Organische elektrolumineszente Anzeige nach Anspruch 1, wobei mindestens eine Position auf mindestens einer Seite der zweiten Spannungsleitung mit der zweiten Spannung versorgt wird.
9. Organische elektrolumineszente Anzeige nach Anspruch 1, wobei die Vielzahl von Kontaktlöchern kongruent ist, und wobei benachbarte Kontaktlöcher in gleichem Abstand voneinander angeordnet sind.
10. Organische elektrolumineszente Anzeige, aufweisend:
- einen Pixelbereich, auf welchem eine Vielzahl von Pixeln angeordnet ist, wobei jeder Pixel eine erste Pixelelektrode, eine zweite Elektrode und einen organischen Dünnschichtfilm, welcher zwischen der ersten Elektrode und der zweiten Elektrode angeordnet ist, aufweist;
eine erste Spannungsleitung zur Versorgung der ersten Pixelelektroden des Pixelbereichs mit einer ersten Spannung;
eine zweite Spannungsleitung zur Versorgung der zweiten Elektrode mit einer zweiten Spannung, wobei die zweite Spannungsleitung mindestens eine Region, welche die zweite Elektrode überlappt, aufweist; und
eine Isolierschicht, welche eine Vielzahl von Kontaktlöchern in der Region, in der die zweite Spannungsleitung die zweite Elektrode überlappt, aufweist,
wobei die zweite Spannungsleitung auf mindestens einer Seite des Pixelbereichs angeordnet ist, und
dadurch gekennzeichnet, dass die zweite Spannungsleitung eine Vielzahl von Hilfsspannungsleitungen zur Versorgung der zweiten Elektrode mit der zweiten Spannung aufweist.
11. Organische elektrolumineszente Anzeige nach Anspruch 10, wobei eine Vielzahl von Punkten niedrigster Stromdichte in der Region, in welcher die zweite Spannungsleitung die zweite Elektrode überlappt, existiert, wobei alle diese Punkte die gleiche Stromdichte aufweisen.
12. Organische elektrolumineszente Anzeige nach Anspruch 10, wobei alle Kontaktlöcher rechteckig oder quadratisch sind.
13. Organische elektrolumineszente Anzeige nach An-

- spruch 12, wobei der Abstand zwischen den benachbarten Kontaktlöchern in Zeilen- und Spaltenrichtung gleich mindestens einer der Längen jedes Kontaktlochs in Zeilen- und Spaltenrichtung oder kleiner als mindestens eine der Längen jedes Kontaktlochs in Zeilen- und Spaltenrichtung ist.
- 5
14. Organische elektrolumineszente Anzeige nach Anspruch 12, wobei der Abstand zwischen benachbarten Kontaktlöchern in Zeilen- und Spaltenrichtung gleich der kleinsten Länge jedes Kontaktlochs in Zeilen- und Spaltenrichtung oder kleiner als die kleinste Länge jedes Kontaktlochs in Zeilen- und Spaltenrichtung ist.
- 10
15. Organische elektrolumineszente Anzeige nach Anspruch 10, wobei alle Kontaktlöcher kreisförmig oder elliptisch sind.
- 15
16. Organische elektrolumineszente Anzeige nach Anspruch 15, wobei der Abstand zwischen benachbarten Kontaktlöchern gleich dem Durchmesser des Kontaktlochs oder kleiner als der Durchmesser des Kontaktlochs ist, wenn das Kontaktloch kreisförmig ist.
- 20
17. Organische elektrolumineszente Anzeige nach Anspruch 10, wobei die Hilfsspannungsleitungen dazu angeordnet sind, die zweite Elektrode von mindestens zwei Seiten der zweiten Spannungsleitung her mit der zweiten Spannung zu versorgen.
- 30
18. Organische elektrolumineszente Anzeige nach Anspruch 17, wobei die Hilfsspannungsleitungen dazu angeordnet sind, die zweite Elektrode von mindestens einer Position jeder Seite der zweiten Spannungsleitung her mit der zweiten Spannung zu versorgen.
- 35
19. Organische elektrolumineszente Anzeige nach Anspruch 10, wobei die Vielzahl von Kontaktlöchern kongruent ist, und wobei benachbarte Kontaktlöcher in gleichem Abstand voneinander angeordnet sind.
- 40
20. Organische elektrolumineszente Anzeige nach Anspruch 10, wobei die Summe der Umfänge jedes Kontaktlochs größer als der Umfang der Region, in welcher sich die zweite Spannungsleitung und die zweite Elektrode überlappen, ist.
- 45
21. Organische elektrolumineszente Anzeige, aufweisend:
- 50
- einen Pixelbereich, auf welchem eine Vielzahl von Pixeln angeordnet ist, wobei jeder Pixel eine erste Pixelelektrode, eine zweite Elektrode und einen organischen Dünnschichtfilm, welcher zwischen der ersten Elektrode und der zweiten Elektrode angeordnet ist, aufweist;
- 55
- eine erste Spannungsleitung zur Versorgung der ersten Pixelelektroden des Pixelbereichs mit einer ersten Spannung;
- eine zweite Spannungsleitung zur Versorgung der zweiten Elektrode mit einer zweiten Spannung, wobei die zweite Spannungsleitung mindestens eine Region, welche die zweite Elektrode überlappt, aufweist; und
- eine Isolierschicht, welche eine Vielzahl von Kontaktlöchern in der Region, in der die zweite Spannungsleitung die zweite Elektrode überlappt, aufweist,
- wobei die Vielzahl von Kontaktlöchern in einer Matrix aus Zeilen und Spalten angeordnet ist und die zweite Elektrode an die zweite Spannungsleitung ankoppelt, und
- wobei die Isolierschicht mindestens zwei Kontaktlöcher in Spaltenrichtung aufweist, und **dadurch gekennzeichnet, dass** alle Kontaktlöcher kreisförmig oder elliptisch sind.
22. Organische elektrolumineszente Anzeige nach Anspruch 21, wobei die Vielzahl von Kontaktlöchern kongruent ist, und wobei benachbarte Kontaktlöcher in gleichem Abstand voneinander angeordnet sind.
- 25
23. Organische elektrolumineszente Anzeige nach Anspruch 22, wobei der Abstand zwischen den benachbarten Kontaktlöchern in Zeilen- und Spaltenrichtung gleich mindestens einer der Längen jedes Kontaktlochs in Zeilen- und Spaltenrichtung oder kleiner als mindestens eine der Längen jedes Kontaktlochs in Zeilen- und Spaltenrichtung ist.
- 30
24. Organische elektrolumineszente Anzeige nach Anspruch 22, wobei der Abstand zwischen benachbarten Kontaktlöchern in Zeilen- und Spaltenrichtung gleich der kleinsten Länge jedes Kontaktlochs in Zeilen- und Spaltenrichtung oder kleiner als die kleinste Länge jedes Kontaktlochs in Zeilen- und Spaltenrichtung ist.
- 35
25. Organische elektrolumineszente Anzeige nach Anspruch 21, wobei der Abstand zwischen benachbarten Kontaktlöchern gleich dem Durchmesser des Kontaktlochs oder kleiner als der Durchmesser des Kontaktlochs ist, wenn das Kontaktloch kreisförmig ist.
- 40
26. Organische elektrolumineszente Anzeige nach Anspruch 21, wobei mindestens eine Position auf mindestens einer Seite der zweiten Spannungsleitung mit der zweiten Spannung versorgt wird.
- 45
27. Organische elektrolumineszente Anzeige nach Anspruch 21, wobei die Summe der Umfänge jedes Kontaktlochs größer als der Umfang der Region, in

welcher sich die zweite Spannungsleitung und die zweite Elektrode überlappen, ist.

28. Organische elektrolumineszente Anzeige nach Anspruch 21, wobei eine Vielzahl von Punkten niedrigster Stromdichte in der Region, in welcher die zweite Spannungsleitung die zweite Elektrode überlappt, existiert, wobei alle diese Punkte die gleiche Stromdichte aufweisen.

Revendications

1. Affichage électroluminescent organique, comprenant :

une partie de pixel sur laquelle une pluralité de pixels sont agencés avec une première électrode de pixel, une deuxième électrode, et une couche de film mince organique interposée entre les première et deuxième électrodes ;
 une première ligne de puissance fournissant une tension de premier niveau aux premières électrodes de pixel de la partie de pixel ;
 une deuxième ligne de puissance ayant au moins une région chevauchant la deuxième électrode pour fournir une tension de deuxième niveau à la deuxième électrode ; et
 une couche d'isolation ayant une pluralité de trous de contact dans la région où la deuxième ligne de puissance chevauche la deuxième électrode,
caractérisé en ce que la somme des circonférences ou des périmètres de chaque trou de contact est supérieure à la circonférence ou au périmètre de la région de chevauchement.

2. Affichage électroluminescent organique selon la revendication 1, dans lequel une pluralité de points de courant le plus bas ayant un niveau équivalent existent sur la région dans laquelle la deuxième ligne de puissance chevauche la deuxième électrode.

3. Affichage électroluminescent organique selon la revendication 1, dans lequel tous les trous de contact sont rectangulaires ou carrés.

4. Affichage électroluminescent organique selon la revendication 3, dans lequel la distance entre des trous de contact adjacents dans les directions de ligne et de colonne est égale ou inférieure à au moins l'une des longueurs de chaque trou de contact dans les directions de ligne et de colonne.

5. Affichage électroluminescent organique selon la revendication 3, dans lequel la distance entre des trous de contact adjacents dans les directions de ligne et de colonne est égale ou inférieure à la plus faible

longueur de chaque trou de contact dans les directions de ligne et de colonne.

6. Affichage électroluminescent organique selon la revendication 1, dans lequel tous les trous de contact sont circulaires ou elliptiques.

7. Affichage électroluminescent organique selon la revendication 6, dans lequel, lorsque le trou de contact a une forme circulaire, la distance entre des trous de contact adjacents est égale ou inférieure au diamètre du trou de contact.

8. Affichage électroluminescent organique selon la revendication 1, dans lequel la tension de deuxième niveau est fournie au moins à une position sur au moins un côté de la deuxième ligne de puissance.

9. Affichage électroluminescent organique selon la revendication 1, dans lequel la pluralité de trous de contact sont congruents, et des trous de contact adjacents sont équidistants l'un de l'autre.

10. Affichage électroluminescent organique, comprenant :

une partie de pixel sur laquelle une pluralité de pixels sont agencés avec une première électrode de pixel, une deuxième électrode, et une couche de film mince organique interposée entre la première électrode et la deuxième électrode ;
 une première ligne de puissance fournissant une tension de premier niveau aux premières électrodes de pixel de la partie de pixel ;
 une deuxième ligne de puissance ayant au moins une région chevauchant la deuxième électrode pour fournir une tension de deuxième niveau à la deuxième électrode,
 une couche d'isolation ayant une pluralité de trous de contact dans la région où la deuxième ligne de puissance chevauche la deuxième électrode,
 dans lequel la deuxième ligne de puissance est agencée sur au moins un côté de la partie de pixel, et **caractérisé en ce que** la deuxième ligne de puissance comporte une pluralité de lignes de puissance auxiliaires pour fournir la tension de deuxième niveau à la deuxième électrode.

11. Affichage électroluminescent organique selon la revendication 10, dans lequel une pluralité de points de courant le plus bas ayant un niveau équivalent existent sur la région dans laquelle la deuxième ligne de puissance chevauche la deuxième électrode.

12. Affichage électroluminescent organique selon la revendication 10, dans lequel tous les trous de contact

sont rectangulaires ou carrés.

13. Affichage électroluminescent organique selon la revendication 12, dans lequel la distance entre les trous de contact adjacents dans les directions de ligne et de colonne est égale ou inférieure au moins à l'une des longueurs de chaque trou de contact dans les directions de ligne et de colonne. 5
14. Affichage électroluminescent organique selon la revendication 12, dans lequel la distance entre des trous de contact adjacents dans les directions de ligne et de colonne est égale ou inférieure à la plus faible longueur de chaque trou de contact dans les directions de ligne et de colonne. 10
15. Affichage électroluminescent organique selon la revendication 10, dans lequel tous les trous de contact sont circulaires ou elliptiques. 15
16. Affichage électroluminescent organique selon la revendication 15, dans lequel, lorsque le trou de contact est circulaire, la distance entre des trous de contact adjacents est égale ou inférieure au diamètre du trou de contact. 20
17. Affichage électroluminescent organique selon la revendication 10, dans lequel les lignes de puissance auxiliaires sont agencées pour fournir la tension de deuxième niveau au moins à partir de deux côtés de la deuxième ligne de puissance à la deuxième électrode. 25
18. Affichage électroluminescent organique selon la revendication 17, dans lequel les lignes de puissance auxiliaires sont agencées pour fournir la tension de deuxième niveau au moins à partir d'une position de chaque côté de la deuxième ligne de puissance à la deuxième électrode. 30
19. Affichage électroluminescent organique selon la revendication 10, dans lequel la pluralité de trous de contact sont congruents, et des trous de contact adjacents sont équidistants l'un de l'autre. 35
20. Affichage électroluminescent organique selon la revendication 10, dans lequel la somme des circonférences ou des périmètres de chaque trou de contact est supérieure à la circonférence ou au périmètre de la région dans laquelle la deuxième ligne de puissance et la deuxième électrode se chevauchent. 40
21. Affichage électroluminescent organique, comprenant : 45
- une partie de pixel sur laquelle une pluralité de pixels sont agencés avec une première électrode de pixel, une deuxième électrode, et une cou-

che de film mince organique interposée entre la première électrode et la deuxième électrode ; une première ligne de puissance fournissant une tension de premier niveau aux premières électrodes de pixel de la partie de pixel ; une deuxième ligne de puissance ayant au moins une région chevauchant la deuxième électrode pour fournir une tension de deuxième niveau à la deuxième électrode ; et une couche d'isolation ayant une pluralité de trous de contact dans la région où la deuxième ligne de puissance chevauche la deuxième électrode, dans lequel la pluralité de trous de contact sont agencés dans une matrice de lignes et de colonnes et relie la deuxième électrode à la deuxième ligne de puissance, et dans lequel la couche d'isolation comporte au moins deux trous de contact dans la direction de colonne, et **caractérisé en ce que** tous les trous de contact sont circulaires ou elliptiques.

22. Affichage électroluminescent organique selon la revendication 21, dans lequel la pluralité de trous de contact sont congruents, et des trous de contact adjacents sont équidistants l'un de l'autre. 25
23. Affichage électroluminescent organique selon la revendication 22, dans lequel la distance entre des trous de contact adjacents dans les directions de ligne et de colonne est égale ou inférieure à au moins l'une des longueurs de chaque trou de contact dans la direction de ligne et les directions de colonne. 30
24. Affichage électroluminescent organique selon la revendication 22, dans lequel la distance entre des trous de contact adjacents dans les directions de ligne et de colonne est égale ou inférieure à la plus faible longueur de chaque trou de contact dans la direction de ligne et la direction de colonne. 35
25. Affichage électroluminescent organique selon la revendication 21, dans lequel, lorsque le trou de contact est circulaire, la distance entre des trous de contact adjacents est égale ou inférieure au diamètre du trou de contact. 40
26. Affichage électroluminescent organique selon la revendication 21, dans lequel la tension de deuxième niveau est fournie au moins à une position sur au moins un côté de la deuxième ligne de puissance. 45
27. Affichage électroluminescent organique selon la revendication 21, dans lequel la somme des circonférences de chaque trou de contact est supérieure à la circonférence de la région où la deuxième ligne de puissance et la deuxième électrode se chevauchent. 50

28. Affichage électroluminescent organique selon la revendication 21, dans lequel une pluralité de points de courant le plus bas ayant un niveau équivalent existent sur la région dans laquelle la deuxième ligne de puissance chevauche la deuxième électrode. 5

10

15

20

25

30

35

40

45

50

55

FIG. 1

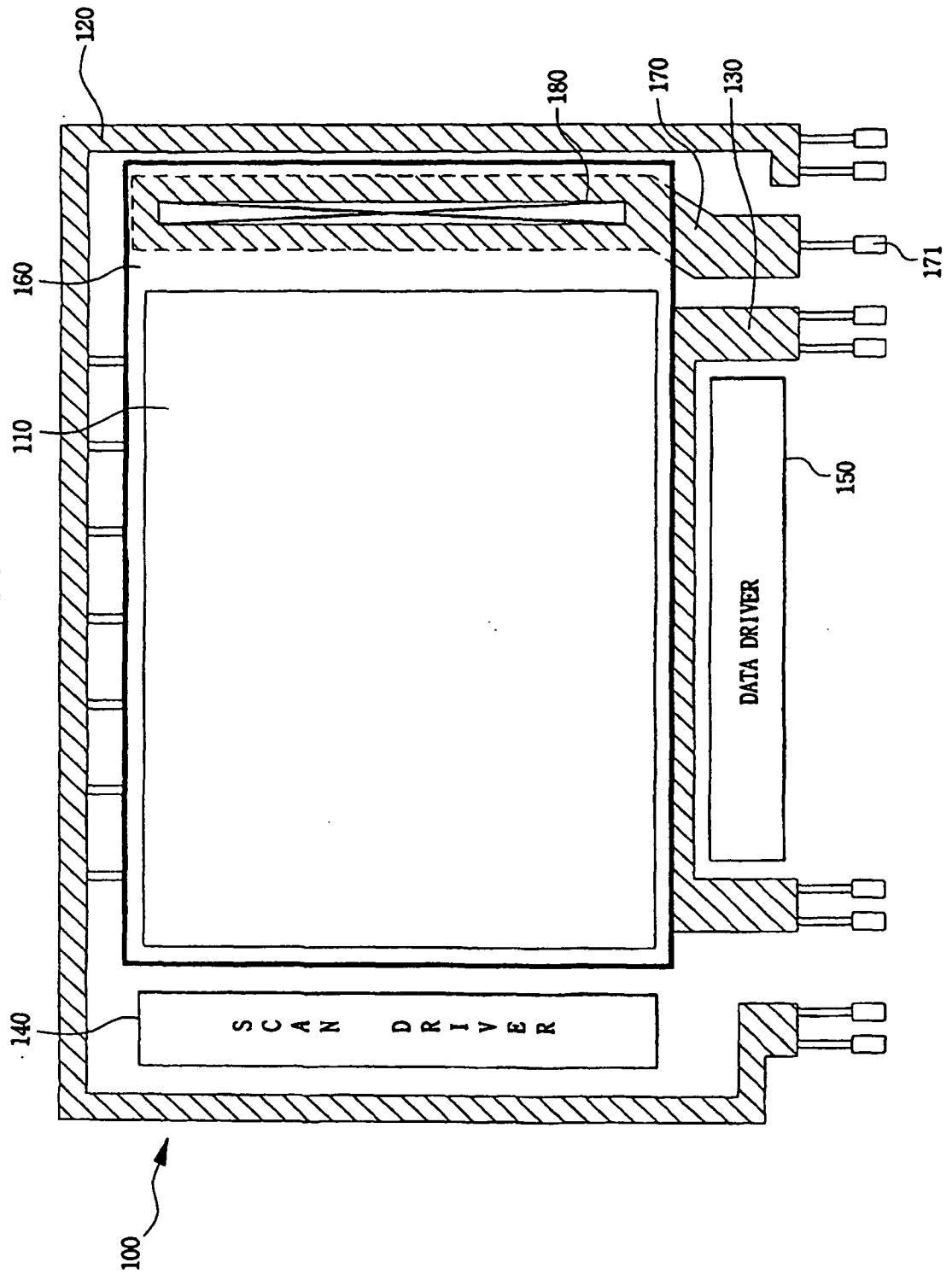

FIG. 2

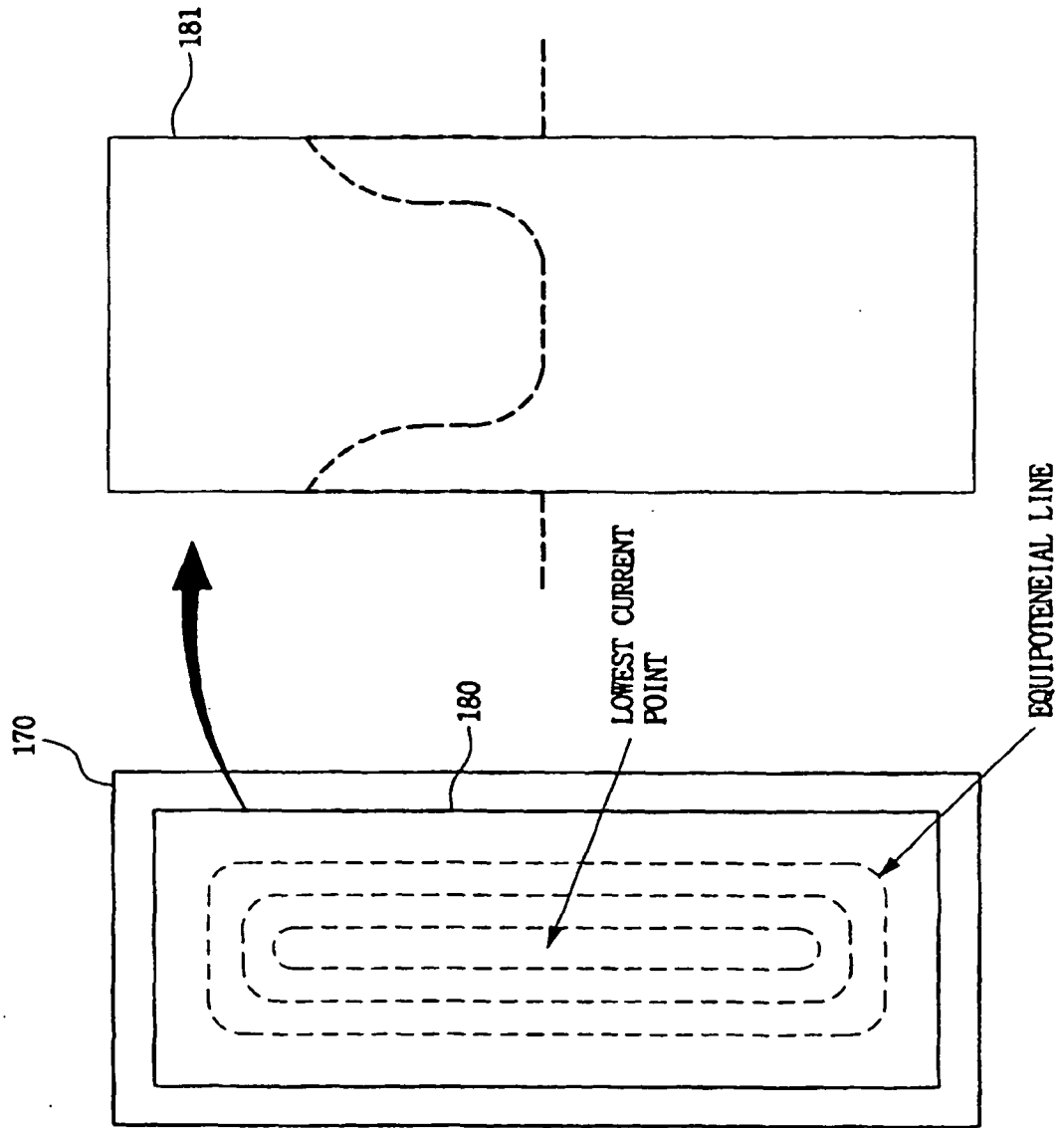

FIG. 3

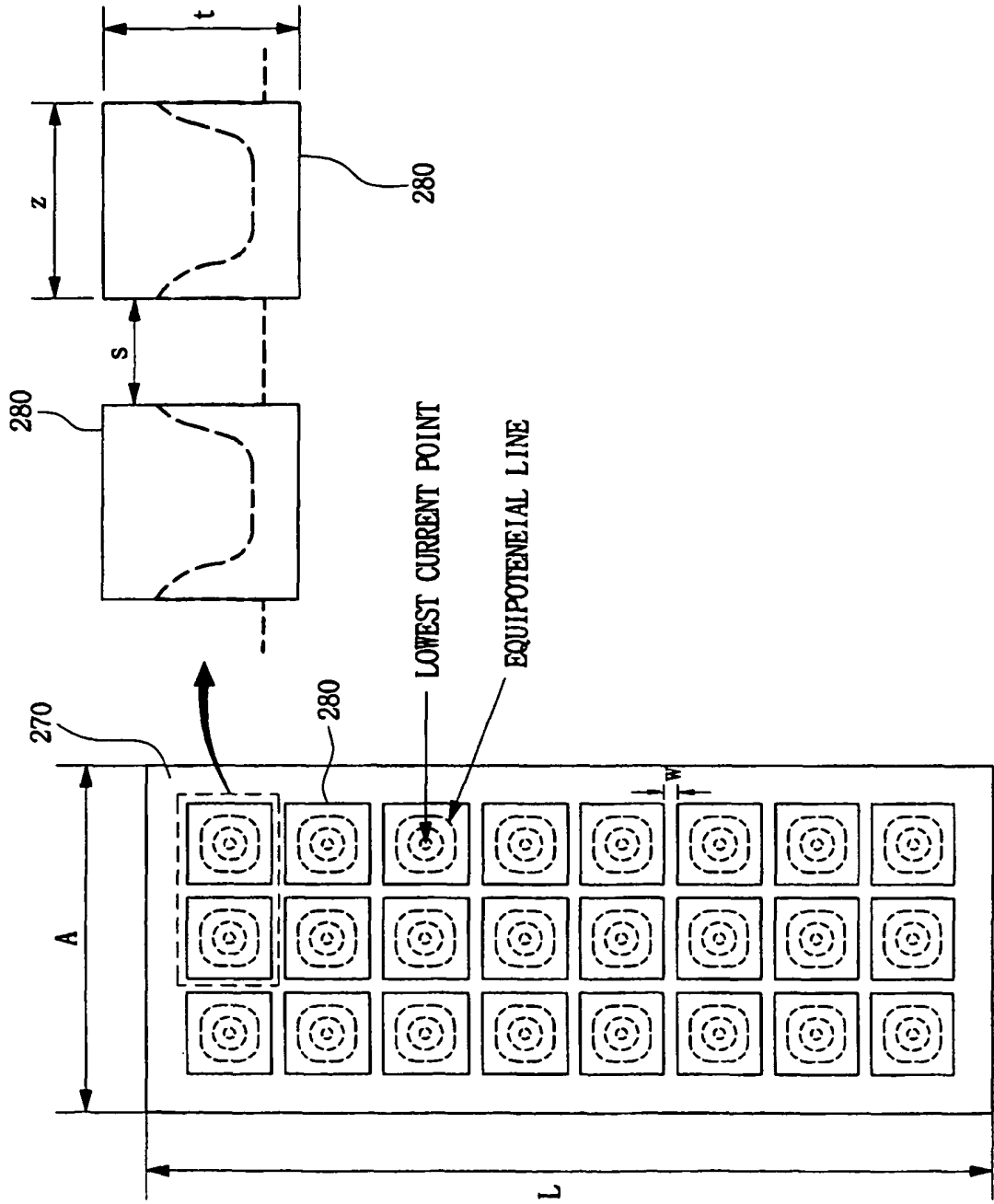

FIG. 4

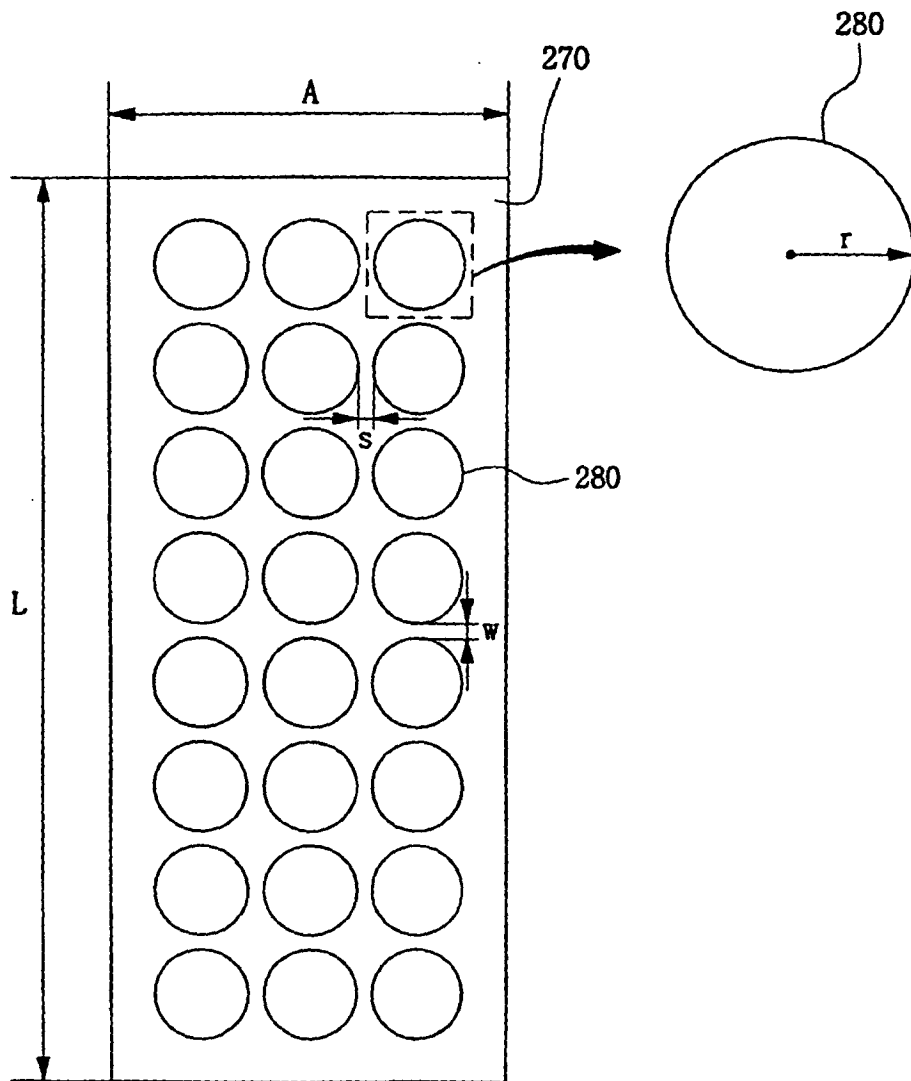

FIG. 5

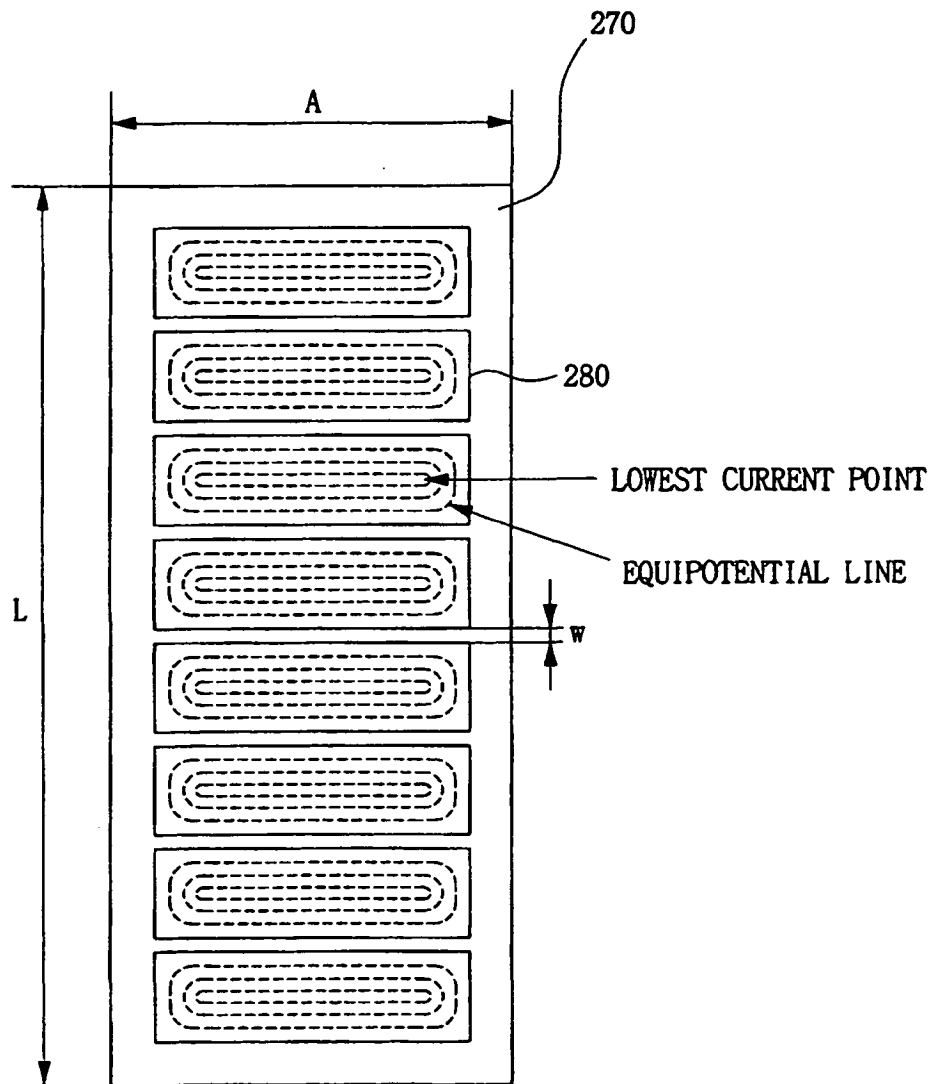
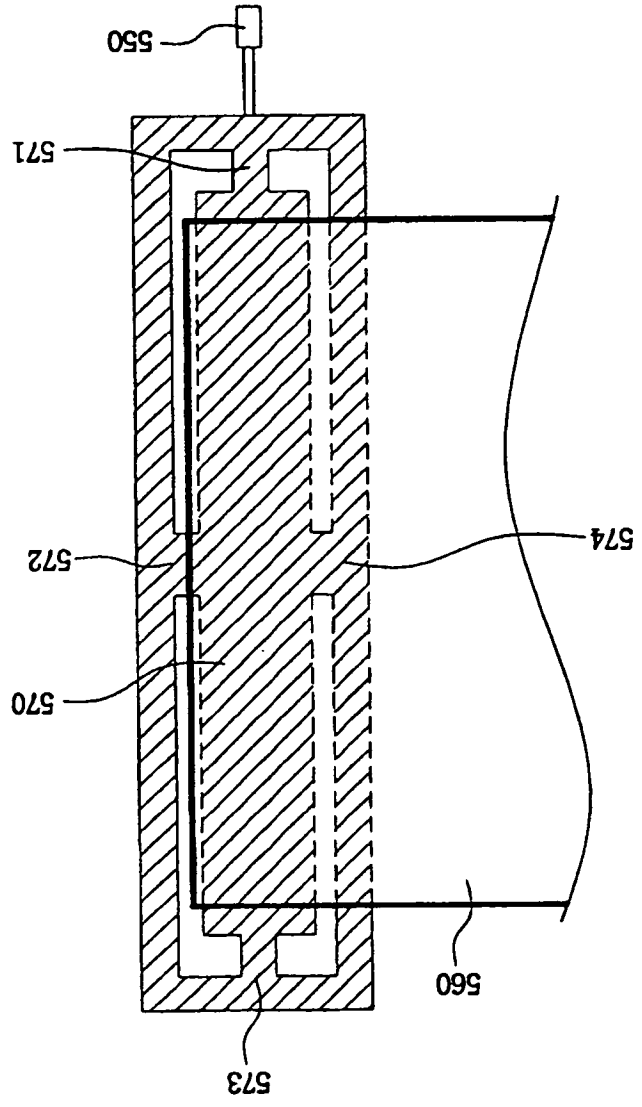

FIG. 6



REFERENCES CITED IN THE DESCRIPTION

This list of references cited by the applicant is for the reader's convenience only. It does not form part of the European patent document. Even though great care has been taken in compiling the references, errors or omissions cannot be excluded and the EPO disclaims all liability in this regard.

Patent documents cited in the description

- US 2002140646 A [0012]
- US 2003146693 A [0012]

专利名称(译)	有机电致发光显示装置		
公开(公告)号	EP1560193B1	公开(公告)日	2007-09-12
申请号	EP2004078425	申请日	2004-12-15
[标]申请(专利权)人(译)	三星斯笛爱股份有限公司		
申请(专利权)人(译)	三星SDI CO. , LTD.		
当前申请(专利权)人(译)	三星SDI CO. , LTD.		
发明人	KWAK, WON-KYU LEGAL & IP TEAM CORPORATE PLANNING KIM, KYONG-DO LEGAL & IP TEAM CORPORATE PLANNING		
IPC分类号	G09G3/32 H01L27/00 H01L51/50 G09F9/30 H01L27/32 H05B33/26		
CPC分类号	H01L27/3279 H01L2251/5315		
代理机构(译)	hengelhaupt , Jürgen		
优先权	1020040000434 2004-01-05 KR		
其他公开文献	EP1560193A1		
外部链接	Espacenet		

摘要(译)

有机电致发光显示器包括像素部分，在像素部分上布置有多个像素，第一电极，第二电极和插入在第一和第二电极之间的有机薄膜层，第一电源线提供第一电平电压到第一电极和第二电极。像素部分的像素；第二电源线（270），具有至少一个与第二电极重叠的区域，用于向第二电极提供第二电平电压；以及绝缘层，在第二电源线之间的重叠区域中具有多个接触孔（280）和第二个电极。每个接触孔的圆周之和大于重叠区域的圆周。

$$(1) \quad L \times A > n(z \times t)$$