



Europäisches Patentamt  
European Patent Office  
Office européen des brevets



(11) **EP 1 399 003 B1**

(12) **EUROPEAN PATENT SPECIFICATION**

(45) Date of publication and mention  
of the grant of the patent:  
**28.12.2005 Bulletin 2005/52**

(51) Int Cl.<sup>7</sup>: **H05B 33/26**, H05B 33/10,  
H01L 27/00

(21) Application number: **03020199.0**

(22) Date of filing: **05.09.2003**

(54) **Organic EL display panel and method for fabricating the same**

Organische elektrolumineszierende Vorrichtung und Methode zu ihrer Herstellung

Dispositif organique électroluminescent et son procédé de fabrication

(84) Designated Contracting States:  
**DE FR GB NL**

(30) Priority: **05.09.2002 KR 2002053562**

(43) Date of publication of application:  
**17.03.2004 Bulletin 2004/12**

(73) Proprietor: **LG ELECTRONICS INC.**  
**Seoul (KR)**

(72) Inventor: **Kim, Chang Nam**  
**Jungnang-gu Seoul (KR)**

(74) Representative: **Vetter, Ewald Otto et al**  
**Meissner, Bolte & Partner**  
**Anwaltssozietät GbR**  
**Postfach 10 26 05**  
**86016 Augsburg (DE)**

(56) References cited:  
**EP-A- 0 966 182**                      **EP-A- 1 022 931**  
**EP-A- 1 168 448**                      **EP-A- 1 195 814**  
**US-A- 4 266 223**                      **US-A- 6 107 735**

**EP 1 399 003 B1**

Note: Within nine months from the publication of the mention of the grant of the European patent, any person may give notice to the European Patent Office of opposition to the European patent granted. Notice of opposition shall be filed in a written reasoned statement. It shall not be deemed to have been filed until the opposition fee has been paid. (Art. 99(1) European Patent Convention).

**Description**

[0001] This application claims the benefit of the Korean Application No. P2002-53562 filed on September 5, 2002.

**BACKGROUND OF THE INVENTION**Field of the Invention

[0002] The present invention relates to display panels, and more particularly, to an organic EL display panel, and a method for fabricating the same.

Background of the Related Art

[0003] As a size of display becomes larger, demands on flat displays that occupies smaller spaces is increasing. As one of the flat displays, the organic EL display is paid attention. The organic EL display panel has advantages in that a thickness is thin, a matrix form of addressing is available, and a driving voltage is as low as below 15V.

[0004] EP 1 168 448 A2 discloses a full color organic EL display panel which has auxiliary electrodes formed in anode lines which connect the light emitting pixels, in order to reduce the resistance of the anode lines. There are a variety of full-color display methods in fabrication of the organic EL display panel, one of which that has the best luminance efficiency is a method employing a shadow mask. FIG. 1 illustrates a section showing a related art method for fabricating an organic EL display panel, and FIG. 2 illustrates a plan view of a shadow mask employed in FIG. 1.

[0005] Referring to FIGS. 1 and 2, in the related art method for fabricating an organic EL display panel, a transparent first electrode 2 is formed on a transparent substrate 1, a barrier (not shown) is formed thereon, and red, green, blue organic EL layer 3-1, 3-2, and 3-3 are formed in succession with a shadow mask 4 as shown in FIG. 2.

[0006] Then, second electrode material is deposited on an entire surface to form a second electrode in an EL region, thereby fabricating a full color organic EL display panel. The first electrode is an anode and a second electrode is a cathode.

[0007] However, the organic EL display panel fabricated thus has waste of power, and a consequential poor efficiency, caused by a resistance of the second electrode (cathode).

[0008] In order to overcome such a poor efficiency, though it is required that the second electrode line has a thickness greater than a certain value, it is difficult to fabricate a thickness greater than the certain value by the foregoing method.

**SUMMARY OF THE INVENTION**

[0009] Accordingly, the present invention is directed to an organic EL display panel, and a method for fabricating the same that substantially obviates one or more of the problems due to limitations and disadvantages of the related art.

[0010] An object of the present invention is to provide an organic EL display panel, and a method for fabricating the same, which can reduce resistances of electrode lines, to improve efficiency.

[0011] Additional features and advantages of the invention will be set forth in the description which follows, and in part will be apparent to those having ordinary skill in the art upon examination of the following or may be learned from practice of the invention. The objectives and other advantages of the invention will be realized and attained by the structure particularly pointed out in the written description and claims hereof as well as the appended drawings.

[0012] To achieve these objects and other advantages and in accordance with the purpose of the present invention, as embodied and broadly described herein, the organic EL display panel having an EL region at a cross of each of first and second electrodes, includes an electric insulating barrier formed between adjacent second electrodes for electrical insulation of the second electrodes, and a supplementary electrode around each of the EL regions, the supplementary electrode being electrically connected to one of the second electrodes.

[0013] The second electrode and the supplementary electrode are electrically connected in the vicinity of an edge of the EL region.

[0014] The supplementary electrode is formed of a material selected from Cr, Al, Au, W, Cu, Ni, and Ag.

[0015] In another aspect of the present invention, there is provided an organic EL display panel including a substrate, first electrodes on the substrate, first supplementary electrodes electrically connected to sides of the first electrodes respectively, second electrodes perpendicular to the first electrodes, an organic EL layer at every cross of the first and second electrodes, second supplementary electrodes electrically connected to the second electrodes around the EL layers respectively, and an electric insulating barrier between adjacent second electrodes for electric insulation of the second electrodes.

[0016] In further aspect of the present invention, there is provided a method for fabricating an organic EL display panel having an EL region at every cross of first and second electrodes, including the steps of forming a plurality of first electrodes at regular intervals on a transparent substrate, forming an insulating layer in regions other than the EL regions, forming second supplementary electrodes on the insulating layer, forming an electric insulating barrier between adjacent EL regions perpendicular to the first electrodes, forming an organic EL layer in each of the EL regions with a shadow mask,

depositing an electrode material on an entire surface inclusive of the organic EL layer, to form a plurality of second electrodes electrically connected to the second supplementary electrodes, and forming a protection film on an entire surface inclusive of the second electrodes.

[0017] The step of forming a plurality of first electrodes further includes the step of forming first supplementary electrodes electrically connected to sides of the first electrodes.

[0018] The second supplementary electrodes includes projected parts in the vicinity of edges of the EL regions so as to be in contact with the second electrodes, respectively.

[0019] It is to be understood that both the foregoing description and the following detailed description of the present invention are exemplary and explanatory and are intended to provide further explanation of the invention claimed.

### **BRIEF DESCRIPTION OF THE DRAWINGS**

[0020] The accompanying drawings, which are included to provide a further understanding of the invention, illustrate embodiment(s) of the invention and together with the description serve to explain the principle of the invention. In the drawings;

[0021] FIG. 1 illustrates a section showing a related art method for fabricating an organic EL display panel;

FIG 2 illustrates a plan view of a shadow mask employed in FIG. 1;

FIGS. 3A ~ 3G illustrate perspective views each showing the steps of a method for fabricating an organic EL display panel in accordance with a preferred embodiment of the present invention;

FIGS. 4A ~ 4G illustrate plan views each showing the steps of a method for fabricating an organic EL display panel in accordance with a preferred embodiment of the present invention;

FIG. 5A illustrates a section across a line I-I in FIG 4G; and

FIG. 5B illustrates a section across a line II-II in FIG. 4G.

### **DETAILED DESCRIPTION OF THE PREFERRED EMBODIMENT**

[0022] Reference will now be made in detail to the preferred embodiments of the present invention, examples of which are illustrated in the accompanying drawings. FIGS. 3A ~ 3G illustrate perspective views each showing the steps of a method for fabricating an organic EL display panel in accordance with a preferred embodiment of the present invention, and FIGS. 4A ~ 4G illustrate plan views each showing the steps of a method for fabricating an organic EL display panel in accordance with a preferred embodiment of the present invention.

[0023] Referring to FIGS. 3A and 4A, first electrodes 11 and pads 11-2 of second electrodes are formed of

transparent material on a transparent substrate 10.

[0024] Then, referring to FIG. 3B and 4B, for reducing resistance of the first electrodes 11, a first supplementary electrode 11-1 is formed such that a part of the first supplementary electrode 11-1 is overlapped with an edge of each of the first electrodes 11. The first supplementary electrode 11-1 is formed of a metal that has a resistance relatively lower than ITO of the first electrode 11, such as Cr, Al, Cu, W, Au, Ni, and Ag.

[0025] Referring to FIGS. 3C and 4C, an insulating layer 12 is formed in region except an EL region. The insulating layer 12 may be formed of any organic or inorganic material, as far as the material is insulator.

[0026] Referring to FIGS. 3D and 4D, a second supplementary electrodes 13 are formed on the insulating layer 12. Each of the second supplementary electrodes 13 has a projected part 13-1 in the vicinity of the edge of the EL region so as to be in contact with each of the second electrodes, electrically. The second supplementary electrode 13 to be in contact with each of the second electrodes is formed of a metal having a resistance lower than the second electrodes relatively, such as Cr, Al, Cu, W, Au, Ni, and Ag.

[0027] Referring to FIGS. 3E and 4E, a buffer layer (not shown) is formed between adjacent EL regions in a direction perpendicular to the first electrode 11, and an electric insulating barrier on each of the buffer layers.

[0028] Referring to FIGS. 3F and 4F, an organic EL layer 16 is formed in each of the EL regions with a shadow mask 15 having a plurality of via holes 15-1. The via holes 15-1 in the shadow mask 15 are in conformity with the EL regions.

[0029] Then, referring to FIGS. 3G and 4G, an electrode material is deposited on an entire surface inclusive of the organic EL layer, to form a plurality of second electrodes 17 electrically connected to the second supplementary electrodes 13, respectively.

[0030] Though not shown, a protection film is formed on an entire surface inclusive of the second electrode 17, and an encapsulation is carried out, to finish fabrication of the organic EL display panel. The first electrode is an anode and the second electrode is cathode.

[0031] FIG. 5A illustrates a section across a line I-I in FIG. 4G, and FIG. 5B illustrates a section across a line II-II in FIG. 4G

[0032] Referring to FIGS. 5A and 5B, the organic EL display panel of the present invention has an EL region at every cross of the first electrodes 11 and the second electrodes 17.

[0033] Moreover, the electric insulating barrier 14, formed on each of the buffer layers 18 between adjacent EL regions, insulates the second electrodes 17 from each other, electrically.

[0034] Furthermore, the second supplementary electrode 13, formed around each of the EL regions, is connected to each of the second electrodes 17, electrically. Each of the second electrodes 17 is connected to one of the projected parts 13-1 of the second supplementary

electrodes 13.

**[0035]** Thus, since the second supplementary electrode can reduce a resistance of the second electrode (cathode), an efficiency of the organic EL display can be improved, and a power required for operating the organic EL display can be reduced, to reduce waste of power.

**[0036]** It will be apparent to those skilled in the art that various modifications and variations can be made in the present invention.

### Claims

1. An organic EL display panel having an EL region at a cross of each of first and second electrodes (11,17), comprising:

an electric insulating barrier (14) formed between adjacent second electrodes for electrical insulation of the second electrodes (17); and a supplementary electrode (13) around each of the EL regions, the supplementary electrode being electrically connected to one of the second electrodes (17) in order to reduce the resistance of the second electrode (17).

2. The organic EL display panel as claimed in claim 1, wherein the second electrode (17) and the supplementary electrode (13) are electrically connected in the vicinity of an edge of the EL region.

3. The organic EL display panel as claimed in claim 1, wherein the supplementary electrode (13) is formed of a material selected from Cr, Al, Au, W, Cu, Ni, and Ag.

4. The organic EL display panel as claimed in claim 1, wherein the supplementary electrode (13) is formed on an insulating layer (12).

5. An organic EL display panel comprising:

a substrate (10);  
 first electrodes on the substrate (11);  
 first supplementary electrodes (11-1) electrically connected to sides of the first electrodes (11), respectively, in order to reduce the resistance of the first electrodes (11);  
 second electrodes (17) perpendicular to the first electrodes (11);  
 an organic EL layer at every cross of the first and second electrodes (11,17);  
 second supplementary electrodes (13) electrically connected to the second electrodes (17) around the EL layers, respectively, in order to reduce the resistance of the second electrodes (17); and

an electric insulating barrier (14) between adjacent second electrodes (17) for electric insulation of the second electrodes (17).

6. The organic EL display panel as claimed in claim 6, wherein the second electrodes (17) and the second supplementary electrodes (13) are electrically connected in the vicinity of edges of the EL regions, respectively.

7. The organic EL display panel as claimed in claim 5, wherein the first, and second supplementary electrodes (11-1,13) are formed of a material selected from Cr, Al, Au, W, Cu, Ni, and Ag.

8. The organic EL display panel as claimed in claim 5, wherein the second supplementary electrode (13) is formed on the insulating layer.

9. A method for fabricating an organic EL display panel having an EL region at every cross of first and second electrodes (11,17), comprising the steps of:

forming a plurality of first electrodes (11) at regular intervals on a transparent substrate (10);  
 forming an insulating layer (12) in regions other than the EL regions;  
 forming second supplementary electrodes (13) on the insulating layer (12);  
 forming an electric insulating barrier (14) between adjacent EL regions perpendicular to the first electrodes (11);  
 forming an organic EL layer (16) in each of the EL regions with a shadow mask (15);  
 depositing an electrode material on an entire surface inclusive of the organic EL layer, to form a plurality of second electrodes (17) electrically connected to the second supplementary electrodes (13), so as to reduce the resistance of the second electrode (17); and  
 forming a protection film on an entire surface inclusive of the second electrodes (17).

10. The method as claimed in claim 9, wherein the step of forming a plurality of first electrodes (11) further includes the step of forming first supplementary electrodes (11-1) electrically connected to sides of the first electrodes (11).

11. The method as claimed in claim 9, wherein the second supplementary electrodes (13) includes projected parts in the vicinity of edges of the EL regions so as to be in contact with the second electrodes (17), respectively.

12. The method as claimed in claim 9, wherein the first, and second supplementary electrodes (11-1,13) are formed of a material selected from Cr, Al, Au,

W, Cu, Ni, and Ag.

13. The method as claimed in claim 9, wherein the step of forming an electric insulating barrier (14) includes the steps of;

forming a buffer layer between adjacent EL regions perpendicular to the first electrodes (11), and

forming the electric insulating barrier (14) on each of the buffer layers.

#### Patentansprüche

1. Organisches Elektrolumineszenz-Display-Panel mit einem Elektrolumineszenz-Bereich an einem Kreuz von jeden ersten und zweiten Elektroden (11, 17), aufweisend:

eine elektrische isolierende Barriere (14), die zwischen benachbarten zweiten Elektroden zur elektrischen Isolierung der zweiten Elektroden (17) gebildet ist; und

eine zusätzliche Elektrode (13) um jeden der Elektrolumineszenz-Bereiche, wobei die zusätzliche Elektrode elektrisch mit einer der zweiten Elektroden (17) verbunden ist, um den Widerstand der zweiten Elektrode (17) zu reduzieren.

2. Organisches Elektrolumineszenz-Display-Panel nach Anspruch 1, wobei die zweite Elektrode (17) und die zusätzliche Elektrode (13) elektrisch in der Nähe eines Randes des Elektrolumineszenz-Bereichs verbunden sind.

3. Organisches Elektrolumineszenz-Display-Panel nach Anspruch 1, wobei die zusätzliche Elektrode (13) aus einem Material ausgewählt aus Cr, Al, Au, W, Cu, Ni und Ag gebildet ist.

4. Organisches Elektrolumineszenz-Display-Panel nach Anspruch 1, wobei die zusätzliche Elektrode (13) auf einer Isolierschicht (12) gebildet ist.

5. Organisches Elektrolumineszenz-Display-Panel, aufweisend:

ein Substrat (10);  
erste Elektroden (11) auf dem Substrat;  
erste zusätzliche Elektroden (11-1), welche elektrisch mit jeweiligen Seiten der ersten Elektroden (11) verbunden sind, um den Widerstand der ersten Elektroden (11) zu reduzieren;  
zweite Elektroden (17) senkrecht zu den ersten Elektroden (11);

eine organische Elektrolumineszenz-Schicht an jedem Kreuz der ersten und zweiten Elektroden (11, 17);

zweite zusätzliche Elektroden (13), die elektrisch mit den zweiten Elektroden (17) um die jeweiligen Elektrolumineszenz-Schichten herum verbunden sind, um den Widerstand der zweiten Elektroden (17) zu verringern; und  
eine elektrische Isolierschicht (14) zwischen benachbarten zweiten Elektroden (17) zur elektrischen Isolierung der zweiten Elektroden (17).

6. Organisches Elektrolumineszenz-Display-Panel nach Anspruch 5, wobei die zweiten Elektroden (17) und die zweiten zusätzlichen Elektroden (13) elektrisch in der Nähe der Ränder der Elektrolumineszenz-Bereiche verbunden sind.

7. Organisches Elektrolumineszenz-Display-Panel nach Anspruch 5, wobei die ersten und zweiten zusätzlichen Elektroden (11-1, 13) aus einem Material ausgewählt aus Cr, Al, Au, W, Cu, Ni und Ag gebildet sind.

8. Organisches Elektrolumineszenz-Display-Panel nach Anspruch 5, wobei die zweite zusätzliche Elektrode (13) auf der Isolierschicht gebildet ist.

9. Verfahren zur Herstellung eines organischen Elektrolumineszenz-Display-Panels mit einem Elektrolumineszenz-Bereich an jedem Kreuz erster und zweiter Elektroden (11, 17), die Schritte aufweisend:

Bilden einer Vielzahl erster Elektroden (11) in regelmäßigen Intervallen auf einem transparenten Substrat (10);

Bilden einer Isolierschicht (12) in anderen Bereichen als den Elektrolumineszenz-Bereichen;

Bilden zweiter zusätzlicher Elektroden (13) auf der Isolierschicht (12);

Bilden einer elektrischen isolierenden Barriere (14) zwischen benachbarten Elektrolumineszenz-Bereichen senkrecht zu den ersten Elektroden (11);

Bilden einer organischen Elektrolumineszenz-Schicht (16) in jedem der Elektrolumineszenz-Bereiche mit einer Schattenmaske (15);

Abscheiden eines Elektrodenmaterials auf einer gesamten Oberfläche einschließlich der organischen Elektrolumineszenz-Schicht, um eine Vielzahl zweiter Elektroden (17) zu bilden, die elektrisch mit den zweiten zusätzlichen Elektroden (13) verbunden sind, um so den Widerstand der zweiten Elektrode (17) zu verringern; und

Bilden einer Schutzschicht auf einer gesamten Oberfläche einschließlich den zweiten Elektroden (17).

10. Verfahren nach Anspruch 9, wobei der Schritt des Bildens einer Vielzahl erster Elektroden (11) ferner den Schritt des Bildens erster zusätzlicher Elektroden (11-1) aufweist, die elektrisch mit Seiten der ersten Elektroden (11) verbunden sind. 5
11. Verfahren nach Anspruch 9, wobei die zweiten zusätzlichen Elektroden (13) vortretende Teile in der Nähe von Rändern der Elektrolumineszenz-Bereiche aufweisen, um so mit den jeweiligen zweiten Elektroden (17) in Kontakt zu sein. 10 15
12. Verfahren nach Anspruch 9, wobei die ersten und zweiten zusätzlichen Elektroden (11-1, 13) aus einem Material ausgewählt aus Cr, Al, Au, W, Cu, Ni und Ag gebildet sind. 20
13. Verfahren nach Anspruch 9, wobei der Schritt des Bildens einer elektrischen isolierenden Barriere (14) die Schritte aufweist: 25
- Bilden einer Pufferschicht zwischen benachbarten Elektrolumineszenz-Bereichen senkrecht zu den ersten Elektroden (11), und Bilden der elektrischen isolierenden Barriere (14) auf jeder der Pufferschichten. 30

### Revendications

1. Panneau d'affichage électroluminescent organique comportant une région électroluminescente au croisement de chacune de premières et secondes électrodes (11, 17) comprenant : 35
- une barrière électrique isolante (14) formée entre des secondes électrodes adjacentes en vue de l'isolement électrique des secondes électrodes (17), et 40
- une électrode supplémentaire (13) autour de chacune des régions électroluminescentes, l'électrode supplémentaire étant reliée électriquement à l'une des secondes électrodes (17), de manière à réduire la valeur ohmique de la seconde électrode (17). 45
2. Panneau d'affichage électroluminescent organique selon la revendication 1, dans lequel la seconde électrode (17) et l'électrode supplémentaire (13) sont reliées électriquement au voisinage d'urrbord de la région électroluminescente. 50
3. Panneau d'affichage électroluminescent organique selon la revendication 1, dans lequel l'électrode

supplémentaire (13) est formée d'un matériau choisi parmi Cr, Al, Au, W, Cu, Ni et Ag.

4. Panneau d'affichage électroluminescent organique selon la revendication 1, dans lequel l'électrode supplémentaire (13) est formée sur une couche isolante (12). 5
5. Panneau d'affichage électroluminescent organique comprenant : 10
- un substrat (10),  
des premières électrodes sur le substrat (11),  
des premières électrodes supplémentaires (11-1) reliées électriquement aux côtés des premières électrodes (11), respectivement, de manière à réduire la valeur ohmique des premières électrodes (11),  
des secondes électrodes (17) perpendiculaires aux premières électrodes (11),  
une couche électroluminescente organique à chaque croisement des premières et secondes électrodes (11, 17),  
des secondes électrodes supplémentaires (13) reliées électriquement aux secondes électrodes (17) autour des couches électroluminescentes, respectivement, de manière à réduire la valeur ohmique des secondes électrodes (17), et  
une barrière électrique isolante (14) entre des secondes électrodes adjacentes (17) en vue d'un isolement électrique des secondes électrodes (17). 20 25 30

6. Panneau d'affichage électroluminescent organique selon la revendication 5, dans lequel les secondes électrodes (17) et les secondes électrodes supplémentaires (13) sont reliées électriquement au voisinage des bords des régions électroluminescentes, respectivement. 35
7. Panneau d'affichage électroluminescent organique selon la revendication 5, dans lequel les premières et secondes électrodes supplémentaires (11-1, 13) sont formées d'un matériau choisi parmi Cr, Al, Au, W, Cu, Ni et Ag. 40
8. Panneau d'affichage électroluminescent organique selon la revendication 5, dans lequel la seconde électrode supplémentaire (13) est formée sur la couche isolante. 45 50
9. Procédé de fabrication d'un panneau d'affichage électroluminescent organique comportant une région électroluminescente à chaque croisement de premières et secondes électrodes (11, 17) comprenant les étapes consistant à : 55

former une pluralité de premières électrodes (11) à des intervalles réguliers sur un substrat transparent (10),  
former une couche isolante (12) dans des régions autres que les régions électroluminescentes, 5  
former des secondes électrodes supplémentaires (13) sur la couche isolante (12),  
former une barrière électrique isolante (14) entre des régions électroluminescentes adjacentes perpendiculaires aux premières électrodes (11), 10  
former une couche électroluminescente organique (16) dans chacune des régions électroluminescentes avec un masque de gravure (15), 15  
déposer un matériau d'électrode sur une surface entière y compris la couche électroluminescente organique, pour former une pluralité de secondes électrodes (17) reliées électriquement aux secondes électrodes supplémentaires (13), de façon à réduire la valeur ohmique des secondes électrodes (17), et 20  
former un film de protection sur une surface entière, y compris les secondes électrodes (17). 25

**10.** Procédé selon la revendication 9, dans lequel l'étape de formation d'une pluralité de premières électrodes (11) comprend en outre l'étape consistant à former des premières électrodes supplémentaires (11-1) reliées électriquement aux côtés des premières électrodes (11). 30

**11.** Procédé selon la revendication 9, dans lequel les secondes électrodes supplémentaires (13) comprennent des parties protubérantes au voisinage des bords des régions électroluminescentes de façon à être en contact avec les secondes électrodes (17), respectivement. 35  
40

**12.** Procédé selon la revendication 9, dans lequel les premières et les secondes électrodes supplémentaires (11-1, 13) sont formées d'un matériau choisi à partir de Cr, Al, Au, W, Cu, Ni et Ag. 45

**13.** Procédé selon la revendication 9, dans lequel l'étape de formation d'une barrière électrique isolante (14) comprend les étapes consistant à :

former une couche tampon entre des régions électroluminescentes adjacentes perpendiculairement aux premières électrodes (11), et former la barrière électrique isolante (14) sur chacune des couches tampon. 50  
55

FIG. 1  
Related Art

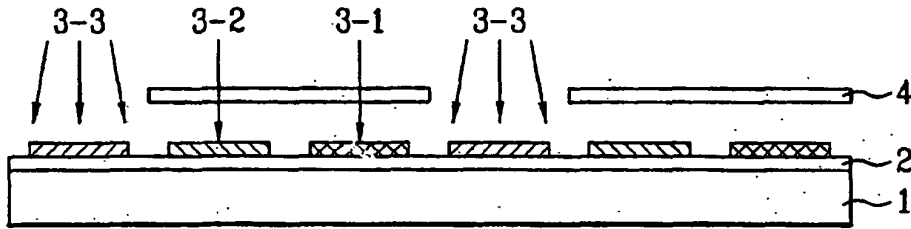

FIG. 2  
Related Art

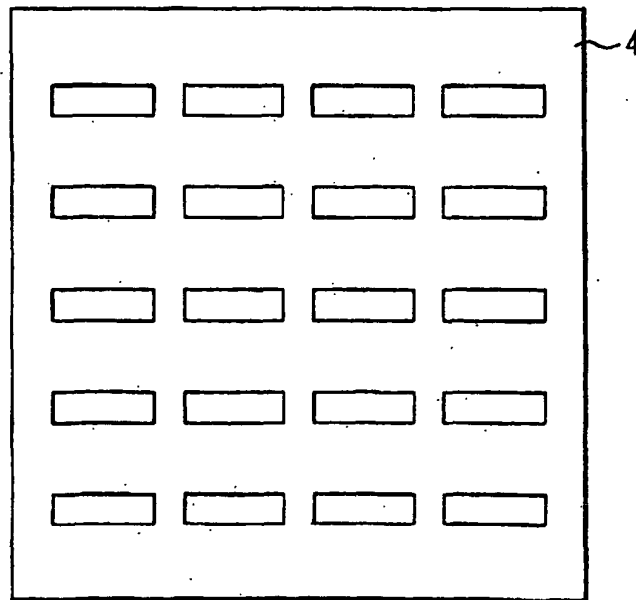

FIG. 3A

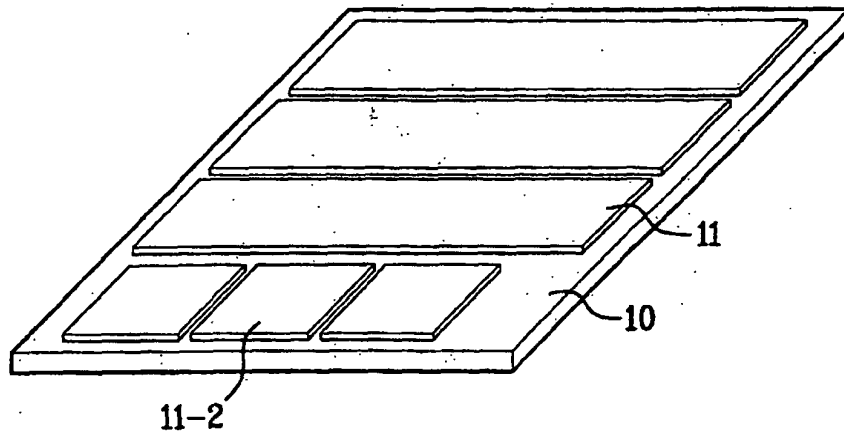

FIG. 3B

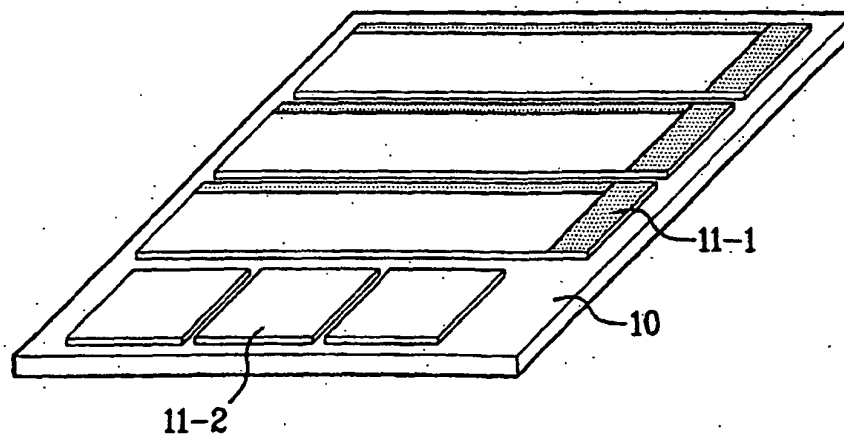

FIG. 3C

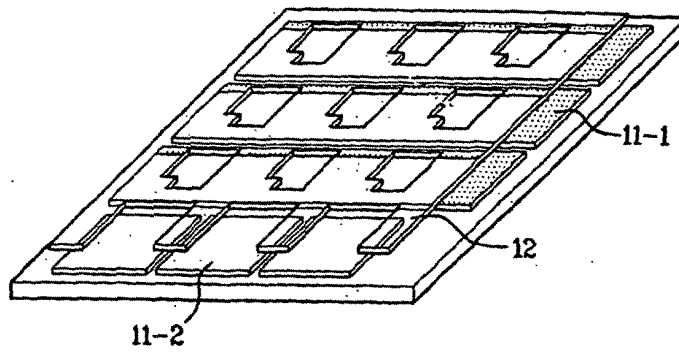

FIG. 3D

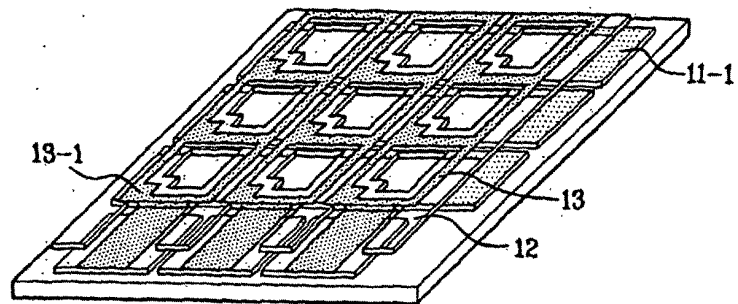

FIG. 3E

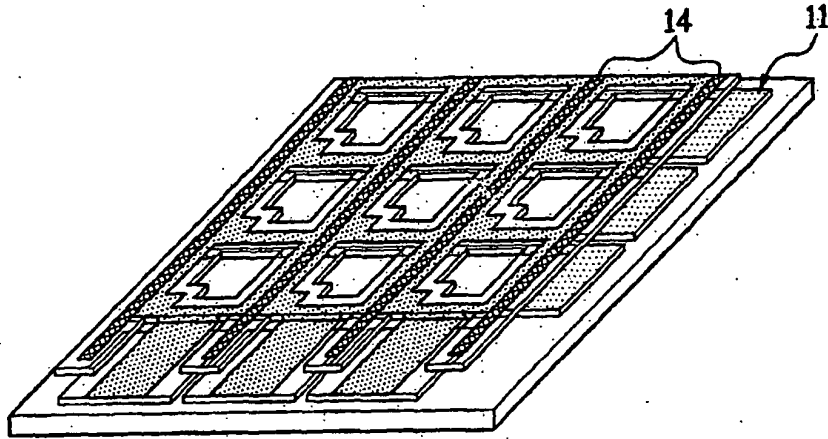

FIG. 3F

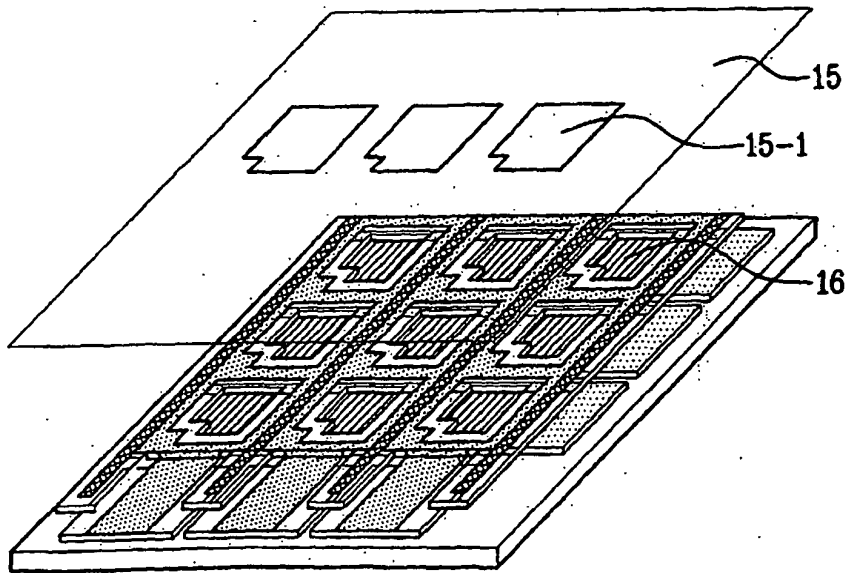

FIG. 3G

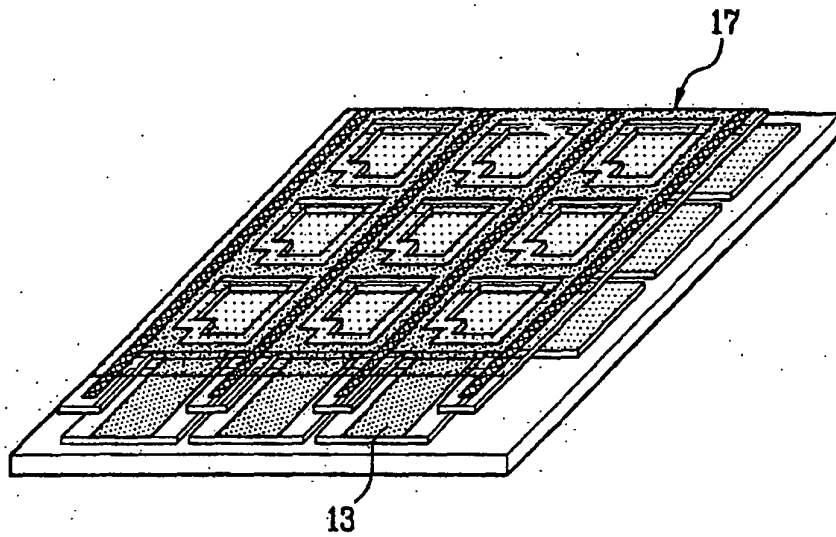

FIG. 4A

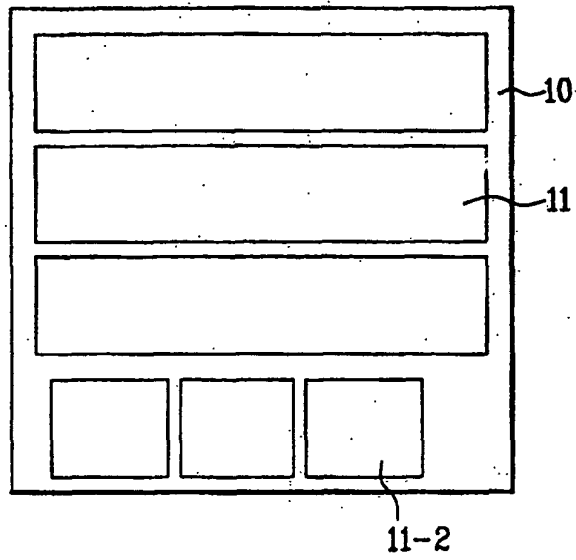

FIG. 4B

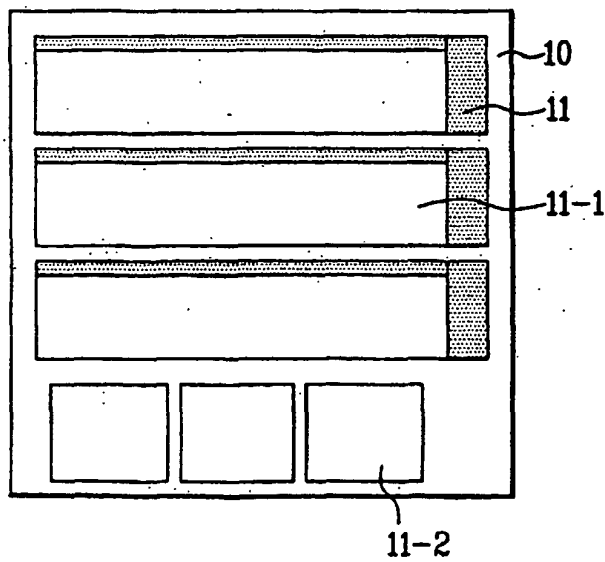

FIG. 4C

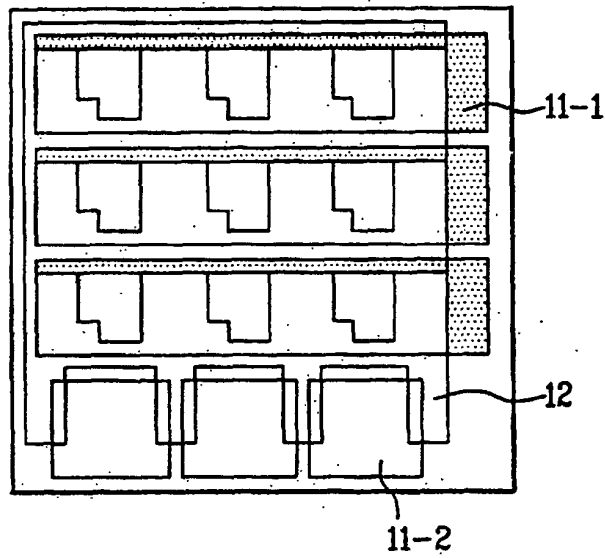

FIG. 4D

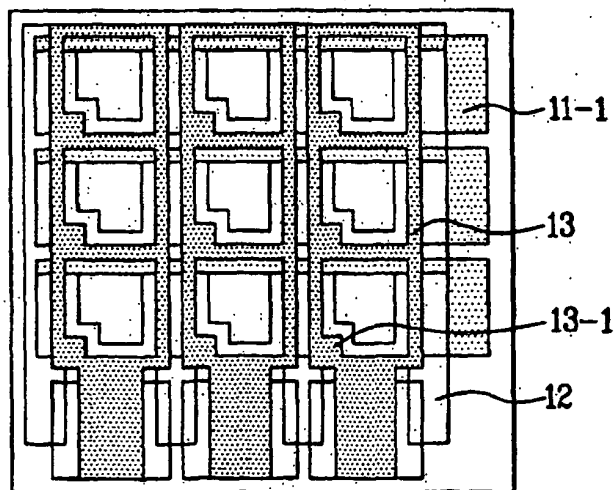

FIG. 4E

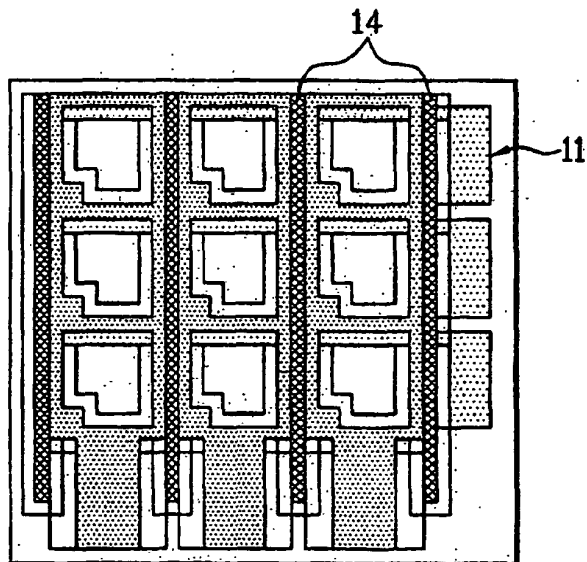

FIG. 4F

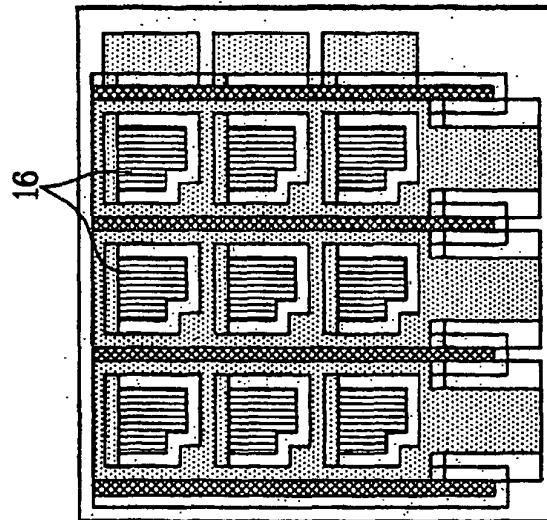
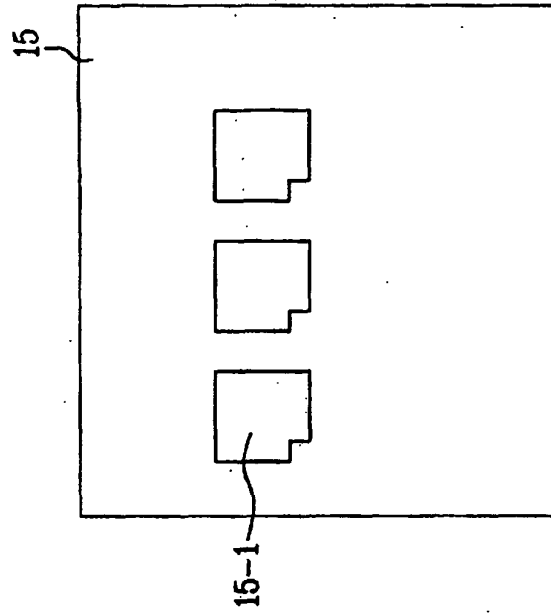



FIG. 5A

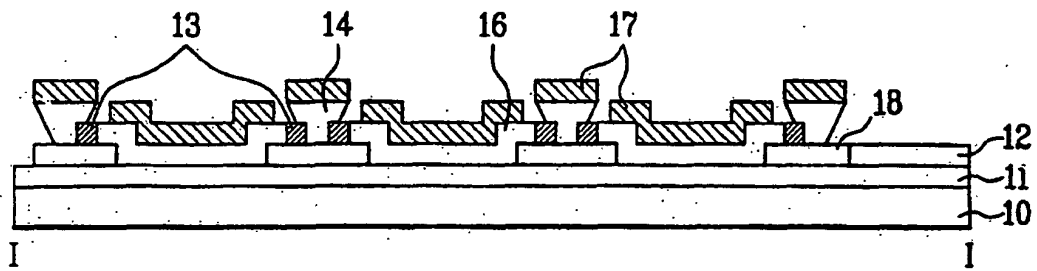
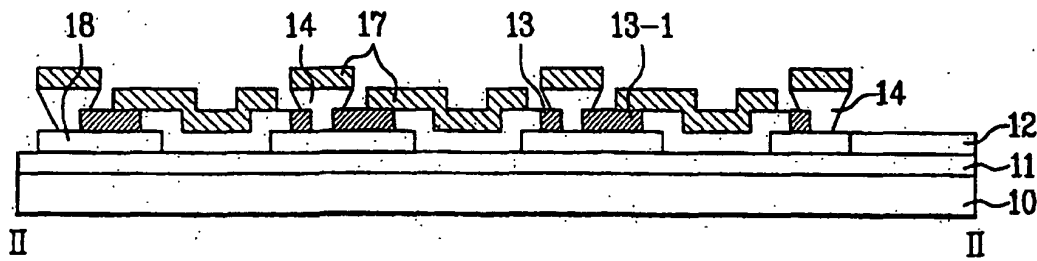

FIG. 5B



专利名称(译)	有机EL显示面板及其制造方法		
公开(公告)号	<a href="#">EP1399003B1</a>	公开(公告)日	2005-12-28
申请号	EP2003020199	申请日	2003-09-05
申请(专利权)人(译)	LG电子株式会社.		
当前申请(专利权)人(译)	LG电子株式会社.		
[标]发明人	KIM CHANG NAM		
发明人	KIM, CHANG NAM		
IPC分类号	H01L27/32 H01L51/50 H01L51/52 H05B33/10 H05B33/22 H05B33/26 H01L27/00		
CPC分类号	H05B33/26 H01L27/3211 H01L27/3281 H01L51/5206 H01L51/5212 H01L51/5221 H05B33/06 H05B33/10 H05B33/14		
优先权	1020020053562 2002-09-05 KR		
其他公开文献	EP1399003A1		
外部链接	<a href="#">Espacenet</a>		

摘要(译)

1.一种用于制造在第一和第二电极的每一交叉处具有EL区域的有机EL显示面板的方法，包括以下步骤：在透明基板上以规则间隔形成多个第一电极，在除了EL区域之外的区域中形成绝缘层，在绝缘层上形成第二辅助电极，在垂直于第一电极的相邻EL区之间形成电绝缘壁，在每个EL区中用阴影掩模形成有机EL层，在包括端面的整个表面上沉积电极材料以形成电连接到第二辅助电极的多个第二电极，以及在包括第二电极的整个表面上形成保护膜。

FIG. 1  
Related Art

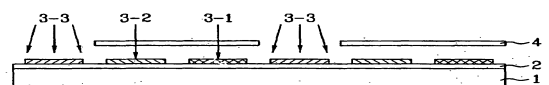

FIG. 2  
Related Art

