



(11) **EP 1 024 473 B1**

(12) **EUROPEAN PATENT SPECIFICATION**

(45) Date of publication and mention of the grant of the patent:  
**13.08.2008 Bulletin 2008/33**

(51) Int Cl.:  
**G09G 3/32<sup>(2006.01)</sup> G09G 3/30<sup>(2006.01)</sup>**

(21) Application number: **00300608.7**

(22) Date of filing: **27.01.2000**

(54) **Active matrix electroluminescent display with grey scale control**

Elektrolumineszenzanzeige mit aktiver Matrix und Graustufensteuerung

Affichage électroluminescent à matrice active avec commande de niveaux de gris

(84) Designated Contracting States:  
**DE FI FR GB NL**

(30) Priority: **29.01.1999 JP 2162499**  
**26.11.1999 JP 33626599**

(43) Date of publication of application:  
**02.08.2000 Bulletin 2000/31**

(73) Proprietor: **Seiko Epson Corporation**  
**Shinjuku-ku**  
**Tokyo 163-0811 (JP)**

(72) Inventor: **Kimura, Mutsumi,**  
**Seiko Epson Corporation**  
**Suwa-shi,**  
**Nagano-ken 392-8502 (JP)**

(74) Representative: **Kenyon, Sarah Elizabeth et al**  
**Miller Sturt Kenyon**  
**9 John Street**  
**London WC1N 2ES (GB)**

(56) References cited:  
**EP-A- 0 261 898 EP-A- 0 671 648**  
**EP-A- 0 671 649 EP-A- 0 810 578**  
**WO-A-99/01856 GB-A- 2 217 088**

- **BECK D R ET AL: "P-37: AMEL POWER CONSIDERATIONS" SID INTERNATIONAL SYMPOSIUM DIGEST OF TECHNICAL PAPERS, US,SANTA ANA, SID, vol. 28, 13 May 1997 (1997-05-13), pages 615-618, XP000722774 ISSN: 0097-966X**

**EP 1 024 473 B1**

Note: Within nine months of the publication of the mention of the grant of the European patent in the European Patent Bulletin, any person may give notice to the European Patent Office of opposition to that patent, in accordance with the Implementing Regulations. Notice of opposition shall not be deemed to have been filed until the opposition fee has been paid. (Art. 99(1) European Patent Convention).

## Description

**[0001]** The present invention generally relates to a display device, especially to an improved technology of gradation display.

**[0002]** TFT-ELDs, namely thin-film-transistor (TFT) driven electroluminescent displays, which include electroluminescent elements (EL elements) driven and controlled by thin film transistors, are considered as future potential displays due to their light weight, small size, high resolution, wide visual field, low electric consumption, etc.

**[0003]** Fig. 4 is a circuit diagram of a conventional TFT-ELD, and Fig. 5 is a cross section of such TFT-ELD. Fig. 4 shows a unit pixel 11 of the TFT-ELD, a scanning line 12, a signal line 13, current supplying line 14, a retention capacitor 15, a selective transistor 16, a driving transistor 17, and an EL element 18. As shown in Fig. 5, the driving transistor 17 for adjusting light emission intensity (gradation) of the EL element 18 is formed on a glass substrate 10. A drain electrode of the driving transistor 17 is connected to a cathode (transparent electrode) 21 of the EL element 18, and a source electrode is connected to the analog signal supply line 14. The EL element 18 is formed of the anode 21, a luminescent layer 22, and an cathode 23. The EL element 18 may be an inorganic electroluminescent element, a low-molecular organic electroluminescent element, or a high-molecular organic electroluminescent element.

**[0004]** The selective transistor 16 includes a gate electrode connected to the scanning line 12, a source electrode connected to a signal line 13, and a drain electrode connected to a gate electrode of the driving transistor 17. The retention capacitor 15 is provided between the analog signal supplying line 14 and the source electrode of the selective transistor 16.

**[0005]** In order to cause the EL element 18 to emit light in the aforementioned structure, the scanning line 12 and the signal line 13 are set at level "H", and current is conducted between the drain and the source of the selective transistor 16, whereby the driving transistor 17 is on state. An analog signal supplied from the analog supplying line 14 in this condition is delivered to the retention capacitor 15 and alters the conductance of the driving transistor 17. As a result, the EL element 18 emits light with light emission intensity pursuant to the analog signal, thereby accomplishing gradations of light emission intensity.

**[0006]** However, as a problem of the above-described structure, resolution of the picture lowers due to the EL element 18 included in each pixel emitting light with unequal light emission intensity, especially in the middle gradation, because of the difference in the transistor properties of the driving transistor 17.

**[0007]** In order to solve this problem, the applicant of the present invention suggested in Japanese Patent Laid-Open Publication No. HEI 11-73158 a technology of displaying respective gradations by controlling on/off states of light emission of EL elements and changing the

luminous area for each gradation. Fig. 6 is a circuit diagram of the TFT-ELD disclosed in said Laid-Open Publication. Fig. 6 shows an EL element included in each pixel, which is formed of EL elements 18-1 and 18-2. Such structure allows display of four gradations by controlling on/off states of EL elements 18-1 and 18-2 respectively via a 2-bit signal line formed of signal lines 13-1 and 13-2. More specifically, there are: gradation "0", where neither EL element 18-1 nor 18-2 emits light; gradation "1", where only EL element 18-1 emits light; gradation "2", where only EL element 18-2 emits light; and gradation "3", where both EL elements 18-1 and 18-2 emit light. Luminous areas of EL element 18-1 and EL element 18-2 are in a ratio of 1:2.

**[0008]** As shown in Fig. 7, in the structure above, signals S, D1, and D2 are respectively supplied to the scanning line 12, signal line 13-1 and signal line 13-2. When signal S is set at level "H", current is conducted between the drain and the sources of selective transistors 16-1 and 16-2. In Fig. 7, gradation "1" is obtained when signal S is set at level "H", signal D1 at level "H", and signal D2 at level "L". As a consequence, driving transistor 17-1 is turned on, and transistor 17-2 is turned off, whereby only EL element 18-1 emits light. Furthermore, in order to realize gradation "2", signal S should be set at level "H", signal D1 at level "L", and signal D2 at level "H". By doing so, driving transistor 17-2 is turned on and transistor 17-1 is turned off, and consequently, only EL element 18-2 emits light.

**[0009]** In this method, driving transistors 17-1 and 17-2 are to be regarded as either almost completely on state or almost completely off state. When driving transistors 17-1 and 17-2 are on state, resistance is negligibly small compared to the resistance of driving transistors 18-1 and 18-2, such that the amount of current conducted through driving transistors 17-1, 17-2, 18-1 and 18-2 depends substantially on the resistance of driving transistors 18-1 and 18-2 alone. Accordingly, light emission intensity is never uneven due to the difference in the transistor properties of driving transistors 18-1 and 18-2. Furthermore, when driving transistors 17-1 and 17-2 are off state, the voltage applied to EL elements 18-1 and 18-2 will be smaller than the threshold voltage, and driving transistors 18-1 and 18-2 will not emit light at all. Therefore, also in this case, the light emission intensity of EL elements 18-1 and 18-2 is never uneven by the difference in the transistor properties of driving transistors 18-1 and 18-2.

**[0010]** However, as a disadvantage of the aforementioned structure, the luminous center (the average position of the luminescent portion) shifts for each gradation and visibility is thereby decreased. Characteristics of such disadvantage will be explained with reference to Fig. 8. Fig. 8 shows a luminous center 40 of the unit pixel element 11. The EL element shown with oblique lines means that no light is emitted, and the EL element shown in white means that light is emitted. In Fig. 8A, the EL elements do not emit light. In Fig. 8B, only EL element

18-1 emits light. In Fig. 8C, only EL elements 18-2 emits light. Finally, in Fig. 8D, both EL elements emit light. It is clear from these drawings that the position of the luminous center 40 changes for each gradation. As a consequence, when the brightness of a displayed image is changed, the position of the image shifts unfavorably. Furthermore, if the displayed image is actually observed here, the displayed image will be seen to flicker, causing an impression of unnatural display or fatigue to the viewer.

**[0011]** GB 2217089A describes a liquid crystal display in which each pixel is constituted by a number of continuous and concentric sub-pixel elements of differing area. The sub-pixel elements may be individually controlled so as to select the active display area of each pixel and, therefore, the intensity of illumination provided by each pixel.

**[0012]** EP 0671649A describes a ferroelectric liquid crystal display in which each pixel is provided with a number of sub-pixel areas which can be independently illuminated so as to provide multiple illumination levels for each pixel. The sub-pixel areas are arranged such that the sub-pixel areas which provide the more intense levels of illumination from a pixel are interspersed one amongst the other so as to reduce the spatial variance at the more intense illumination levels.

**[0013]** Accordingly, the object of the present invention is to overcome such disadvantage and to provide a display device wherein a luminous center does not shift for each light emission gradation.

**[0014]** In the present invention, in order to achieve said object, there is provided a display device comprising a plurality of unit pixels, each of the plurality of the unit pixels including a plurality of luminescent elements being separated mutually and arranged symmetrically with respect to a prescribed position;

a driving means arranged to implement a driving scheme having a state of emission or non-emission for each of the plurality of luminescent elements, the driving scheme corresponding to a symmetrical pattern of emission with respect to the prescribed position; wherein the display device is characterised in that:

the plurality of luminescent elements includes at least one pair of luminescent elements, the luminescent elements in each pair being located symmetrically with respect to the prescribed position;

the luminescent elements in each pair are controlled so as to be both switched on or both switched off concurrently; and

each of the luminescent elements of the unit pixel has the same area.

**[0015]** Such structure allows provision of a display device wherein the position of a luminous center does not change for each gradation. By controlling on/off of the multiple luminescent elements, it is possible to prevent uneven luminance caused by difference in the properties of luminescent elements. In order to achieve the structure above, electroluminescent elements may, for example,

be used as luminescent elements, so that thin-film transistors may control the on/off states of light emission by the luminescent elements.

5 Fig. 1 is an explanatory diagram showing the emission state of the respective EL elements forming a unit pixel in the TFT-ELD according to embodiment 1;

10 Fig. 2 is an explanatory diagram showing a unit pixel in the TFT-ELD according to embodiment 2;

Fig. 3 is an explanatory diagram showing the emission state of the respective EL elements forming a unit pixel in the TFT-ELD according to embodiment 2;

15 Fig. 4 is a circuit diagram of a unit pixel in a conventional TFT-ELD;

Fig. 5 is a cross section of a unit pixel in a conventional TFT-ELD;

20 Fig. 6 is a circuit diagram of a unit pixel in a conventional TFT-ELD;

Fig. 7 is a timing chart indicating a scanning line and a signal line of a conventional TFT-ELD; and

25 Fig. 8 is an explanatory diagram showing the light emission state of the EL elements forming a unit pixel of a conventional TFT-ELD.

(Embodiment 1)

**[0016]** Fig. 1 shows a unit pixel 11 included in a display device according to the present invention. Each unit pixel has EL elements 18-10, 18-21 and 18-22, and is a 2 bit-4 gradation display. In this Fig. 1, EL element 18-10 is an EL element for 0-bit display. The on/off states of EL elements 18-21 and 18-22 are simultaneously controlled by the same driving transistor, and EL element 18-21 is a first EL element for 1-bit display and EL element 18-22 is a second EL element for 1-bit display. Each EL element is driven and controlled by two scanning lines (for 0-bit and 1-bit display) which are not shown in Fig. 1.

30 **[0017]** Furthermore, although Fig. 1 shows only the unit pixel element 11, in reality the unit pixel elements 11 are arranged in a matrix over the entire screen of the display device.

**[0018]** Fig. 1A shows emission by none of the EL elements (gradation "0"); Fig. 1B- emission only by EL element 18-10 (gradation "1"); Fig. 1C - emission only by EL element 18-1 (gradation "2"); and Fig. 1D - emission by all EL elements 18-1, 18-2 and 18-3 (gradation "3").

**[0019]** As shown in Fig. 1, the luminous center 40 for each gradation is located at the same position as the luminous center of the luminescent portion (EL element 18-10), and configured such that it does not shift for each gradation. In other words, the luminescent portion corresponding to gradation "2" is located point-symmetrically with respect to the luminescent portion corresponding to gradation "1". Furthermore, the luminescent portion corresponding to gradation "3" is located point-symmetrically with respect to the luminescent portion corresponding

to gradation "1". By arranging the luminescent portions point-symmetrically around a prescribed point provided at the center, easily obtained is a structure which prevents shifting of the luminous center 40. Accordingly, even when the brightness of a displayed image is changed, unfavorable shifting of the displayed position does not take place. Therefore, the present invention solves disadvantages related to the picture quality, such as flickering of images, or impression of unnatural display or fatigue caused to the viewer.

[0020] Furthermore, although respective EL elements are shaped in quadrilaterals (squares) in Fig. 1, they may be configured as circles or ovals. Moreover, by making the respective areas of EL elements 18-10, 18-21, and 18-22 uniform, light emission intensity for respective gradations may be increased or decreased linearly.

(Embodiment 2)

[0021] Fig. 2 shows a unit pixel 11 included in the display device. Each unit pixel is formed of EL elements 18-10, 18-21, 18-22, 18-31, 18-32, 18-33 and 18-34, and is a 3 bits-8 gradation display. In Fig. 2, EL element 18-10 is an EL element for 0-bit display. The on/off states of EL elements 18-21 and 18-22 are simultaneously controlled by the same driving transistor, and EL element 18-21 is a first EL element for 1-bit display and EL element 18-22 is a second EL element for 1-bit display. Similarly, the on/off states of EL elements 18-31, 18-32, 18-33 and 18-34 are simultaneously controlled by the same driving transistor. EL element 18-31 is a first EL element for 2-bit display, EL element 18-32 is a second EL element for 2-bit display, EL element 18-33 is a third EL element for 2-bit display, and EL element 18-34 is a fourth EL element for 2-bit display. Each EL element is driven and controlled by three scanning lines (for 0 to 2 bit display) which are not shown in Fig. 2.

[0022] Furthermore, although Fig. 2 only shows the unit pixel element 11, in reality the unit pixel elements 11 are arranged in a matrix over the entire screen of the display device.

[0023] Fig. 2A shows that none of the EL elements emit light (gradation "0"); Fig. 2B- emission only by 0-bit display EL element (gradation "1"); Fig. 2C - emission by only a 1-bit display EL element (gradation "2"); and Fig. 2D, emission by 0-bit and 1-bit display EL elements (gradation "3"). Furthermore, Fig. 3A shows emission of only a 2-bit display EL element (gradation "4"); Fig. 3B - emission of only 0-bit and 2-bit display EL elements (gradation "5"); Fig. 3C - emission of only 1-bit and 2-bit display EL elements (gradation "6"); and Fig. 3D - emission of all 0-bit, 1-bit and 2-bit display EL elements (gradation "7").

[0024] As shown in Figs. 2 and 3, the luminous center 40 for each gradation is located at the same position as the center point of the luminescent portion (EL element 18-10), and structured so as to avoid shifting for each gradation. In other words, the luminescent portion corresponding to gradation "2" is located point-symmetrically

with respect to the luminescent portion corresponding to gradation "1". The luminescent portion corresponding to gradation "3" is located point-symmetrically with respect to the luminescent portion corresponding to gradation "1". ... And the luminescent portion corresponding to gradation "7" is located point-symmetrically with respect to the luminescent portion corresponding to gradation "1". By arranging luminescent portions point-symmetrically around a prescribed point provided at the center, easily obtained is a configuration which prevents shifting of the luminous center 40. Accordingly, even when the brightness of a displayed image is changed, unfavorable shifting of the display position does not take place. Therefore, the present invention solves disadvantages related to the picture quality, such as flickering of images, or impression of unnatural display or fatigue caused to the viewer.

[0025] Furthermore, although respective EL elements are shaped in quadrilaterals (squares) in Fig. 2, they may be configured as circles or ovals. Moreover, by making the respective areas of EL elements 18-10, 18-21, and 18-22 uniform, light emission intensity for respective gradations may be increased or decreased linearly.

[0026] Furthermore, although the present embodiment is explained with eight gradations, different gradations may be obtained by adjusting the number of EL elements. The display device according to the present invention may be used for video cameras, digital cameras, car stereos, video CD players, portable terminals, laptop personal computers, etc.

## Claims

1. A display device comprising a plurality of unit pixels, each of the plurality of unit pixels (11) including a plurality of luminescent elements (18-10 to 18-34) being separated mutually from one another and arranged symmetrically with respect to a prescribed position (40);  
a driving means arranged to implement a driving scheme having a state of emission or non-emission for each of the plurality of luminescent elements (18-10 to 18-34), the driving scheme corresponding to a symmetrical pattern of emission with respect to the prescribed position (40); wherein the display device is **characterised in that:**

the plurality of luminescent elements of a unit pixel (18-10 to 18-34) includes at least one pair of luminescent elements (18-21 to 18-22), the luminescent elements (18-21 to 18-22) in the at least one pair being located symmetrically with respect to the prescribed position (40) and being controlled so as to be both switched on or both switched off concurrently; and **in that** each of the luminescent elements of a unit pixel (18-10 to 18-34) has the same area.

2. The display device according to claim 1, wherein the driving means comprises at least one transistor to control at least a pair (18-21, 18-22) of the luminescent elements (18-10 to 18-34).
3. The display device according to claim 1 or 2, wherein the plurality of luminescent elements (18-10 to 18-34) are arranged point symmetrically.
4. The display device according to any one of claims 1 to 3, wherein the unit pixels (11) include three or seven luminescent elements (18-10 to 18-34).
5. The display device according to claim 4, wherein the prescribed position is at a luminous center (40) of the plurality of luminescent elements (18-10 to 18-34).
6. The display device according to claim 5, wherein the prescribed position is a luminous center of a luminescent element that contributes to a gradation of minimum luminance.
7. The display device according to any one of claims 1 to 6, wherein the plurality of luminescent elements (18-10 to 18-34) are arranged in a hexagonal shape.

#### Patentansprüche

1. Anzeigevorrichtung, umfassend mehrere Pixeleinheiten, wobei jede der mehreren Pixeleinheiten (11) mehrere lumineszente Elemente (18-10 bis 18-34) enthält, die wechselseitig voneinander getrennt sind und symmetrisch in Bezug auf eine vorgeschriebene Position (40) angeordnet sind; ein Ansteuerungsmittel, das zum Implementieren eines Ansteuerungsschemas mit einem Emissions- und Nicht-Emissionszustand für jedes der mehreren lumineszenten Elemente (18-10 bis 18-34) angeordnet ist, wobei das Ansteuerungsschema einem symmetrischen Emissionsmuster in Bezug auf die vorgeschriebene Position (40) entspricht; wobei die Anzeigevorrichtung **dadurch gekennzeichnet ist, dass:**

die mehreren lumineszenten Elemente einer Pixeleinheit (18-10 bis 18-34) mindestens ein Paar lumineszenter Elemente (18-21 bis 18-22) enthalten, wobei die lumineszenten Elemente (18-21 bis 18-22) in dem mindestens einen Paar symmetrisch in Bezug auf die vorgeschriebene Position (40) angeordnet sind und so gesteuert werden, dass beide gleichzeitig eingeschaltet oder beide gleichzeitig ausgeschaltet werden; und dass jedes der lumineszenten Elemente einer Pixeleinheit (18-10 bis 18-34) dieselbe Fläche auf-

weist.

2. Anzeigevorrichtung nach Anspruch 1, wobei das Ansteuerungsmittel mindestens einen Transistor zur Steuerung mindestens eines Paares (18-21, 18-22) der lumineszenten Elemente (18-10 bis 18-34) umfasst.
3. Anzeigevorrichtung nach Anspruch 1 oder 2, wobei die mehreren lumineszenten Elemente (18-10 bis 18-34) punktsymmetrisch angeordnet sind.
4. Anzeigevorrichtung nach einem der Ansprüche 1 bis 3, wobei die Pixeleinheiten (11) drei oder sieben lumineszente Elemente (18-10 bis 18-34) enthalten.
5. Anzeigevorrichtung nach Anspruch 4, wobei die vorgeschriebene Position an einem Leuchtzentrum (40) der mehreren lumineszenten Elemente (18-10 bis 18-34) liegt.
6. Anzeigevorrichtung nach Anspruch 5, wobei die vorgeschriebene Position an einem Leuchtzentrum eines lumineszenten Elements liegt, das zu einer Gradation einer minimalen Leuchtdichte beiträgt.
7. Anzeigevorrichtung nach einem der Ansprüche 1 bis 6, wobei die mehreren lumineszenten Elemente (18-10 bis 18-34) in einer hexagonalen Form angeordnet sind.

#### Revendications

1. Dispositif d'affichage comprenant une pluralité de pixels unitaires, chacun parmi la pluralité des pixels unitaires (11) incluant une pluralité d'éléments luminescents (18-10 à 18-34) réciproquement séparés les uns des autres et disposés symétriquement par rapport à une position prescrite (40) ; un moyen d'attaque étudié pour implémenter un schéma d'attaque présentant un état d'émission ou de non émission pour chacun parmi la pluralité des éléments luminescents (18-10 à 18-34), le schéma d'attaque correspondant à un motif symétrique d'émission par rapport à la position prescrite (40); le dispositif d'affichage **se caractérisant en ce que :**

la pluralité des éléments luminescents d'un pixel unitaire (18-10 à 18-34) comprenne au moins une paire d'éléments luminescents (18-21 à 18-22), les éléments luminescents (18-21 à 18-22) dans cette au moins une paire étant situés symétriquement par rapport à la position prescrite (40) et étant commandés de manière à être tous deux allumés ou éteints simultanément; et **en ce que** chacun des éléments luminescents d'un pixel

unitaire (18-10, 18-34) possède la même superficie.

2. Dispositif d'affichage selon la revendication 1, le moyen d'attaque comprenant au moins un transistor pour contrôler au moins une paire (18-21, 18-22) d'éléments luminescents (18-10 à 18-34). 5
3. Dispositif d'affichage selon la revendication 1 ou 2, la pluralité des éléments luminescents (18-10 à 18-34) étant disposés avec une symétrie ponctuelle. 10
4. Dispositif d'affichage selon l'une quelconque des revendications 1 à 3, les pixel unitaires (11) incluant trois ou sept éléments luminescents (18-10 à 18-34). 15
5. Dispositif d'affichage selon la revendication 4, la position prescrite se trouvant au centre lumineux (40) de la pluralité des éléments luminescents (18-10 à 18-34). 20
6. Dispositif d'affichage selon la revendication 5, la position prescrite étant un centre lumineux d'un élément luminescent qui contribue à une gradation de luminance minimale. 25
7. Dispositif d'affichage selon l'une quelconque des revendications 1 à 6, la pluralité des éléments luminescents (18-10 à 18-34) étant disposés en forme d'hexagone. 30

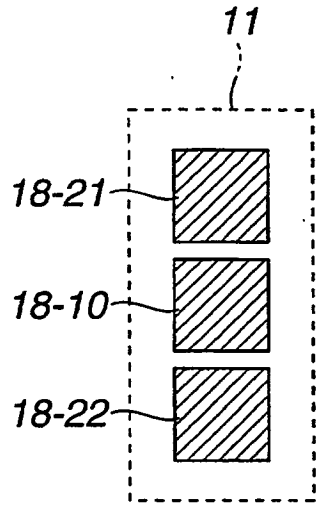
35

40

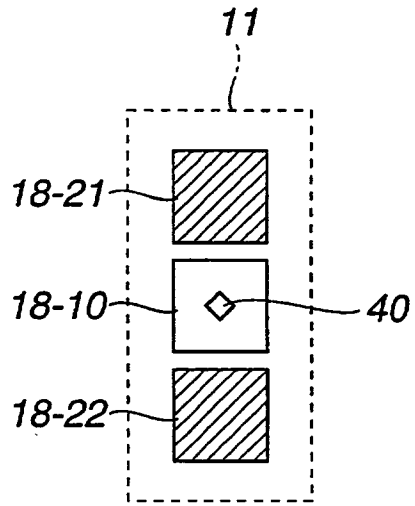
45

50

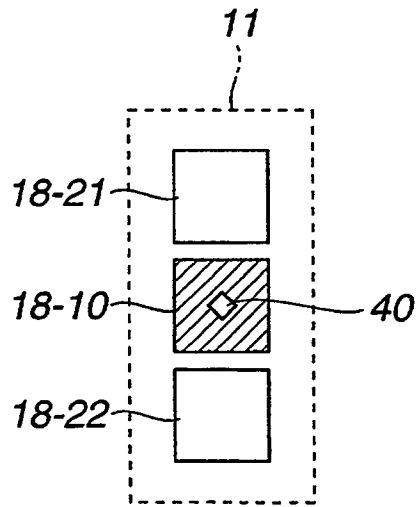
55



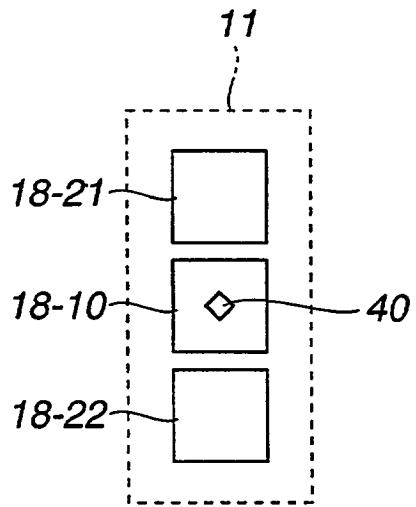
**FIG. 1A**



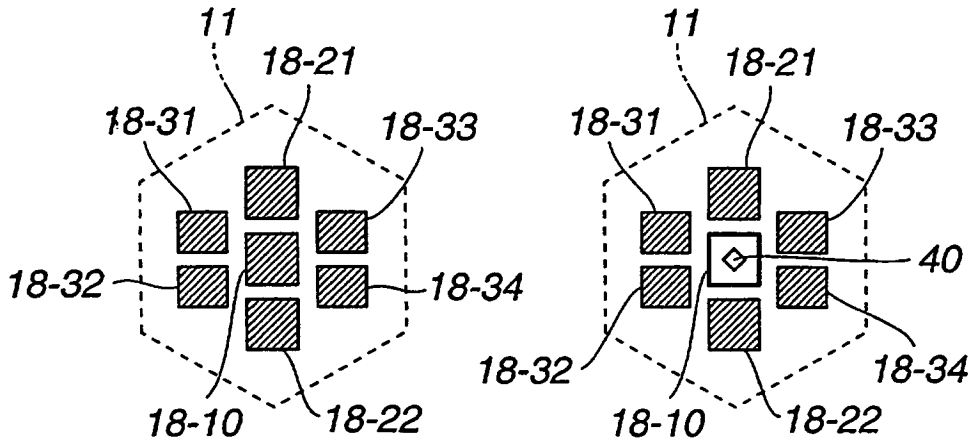
**FIG. 1B**



**FIG. 1C**

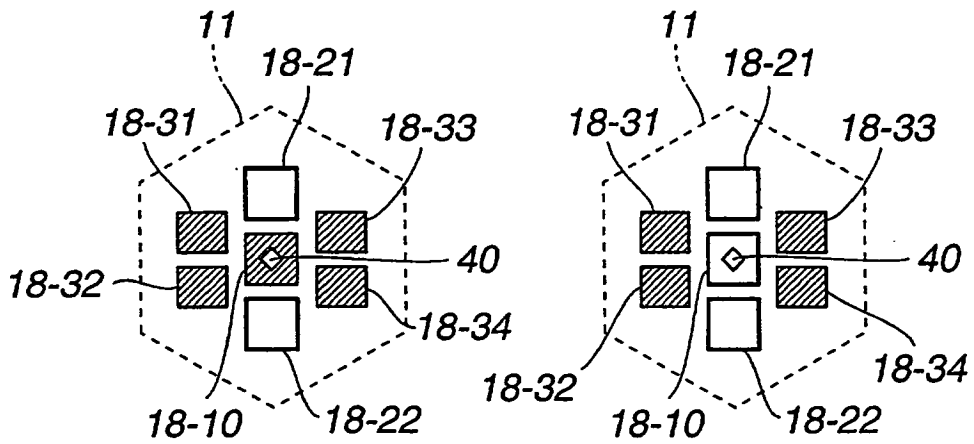


**FIG. 1D**



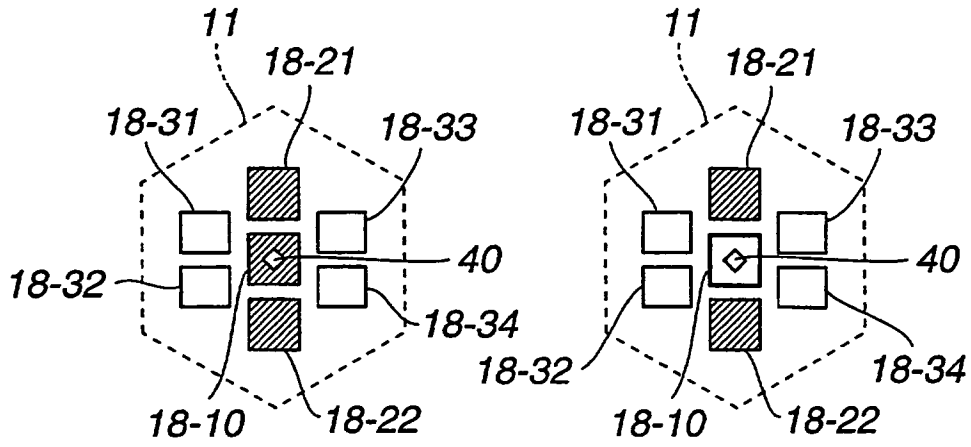
**FIG. 2A**

**FIG. 2B**



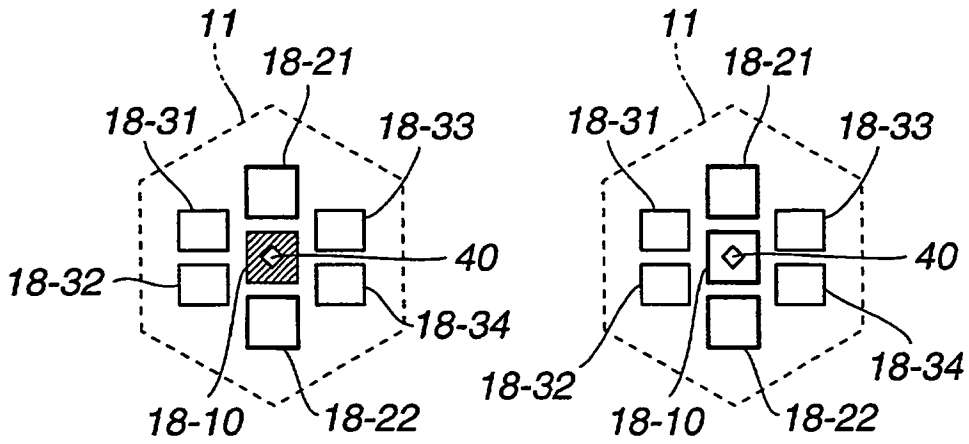
**FIG. 2C**

**FIG. 2D**



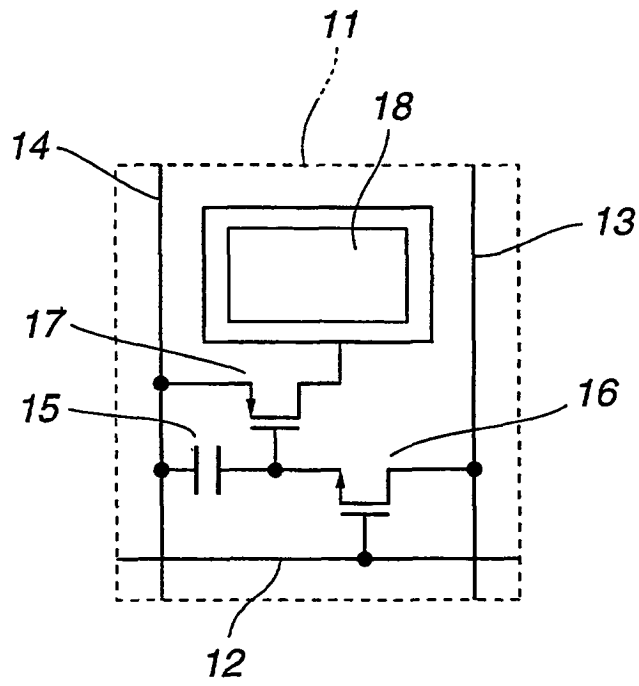
**FIG.3A**

**FIG.3B**

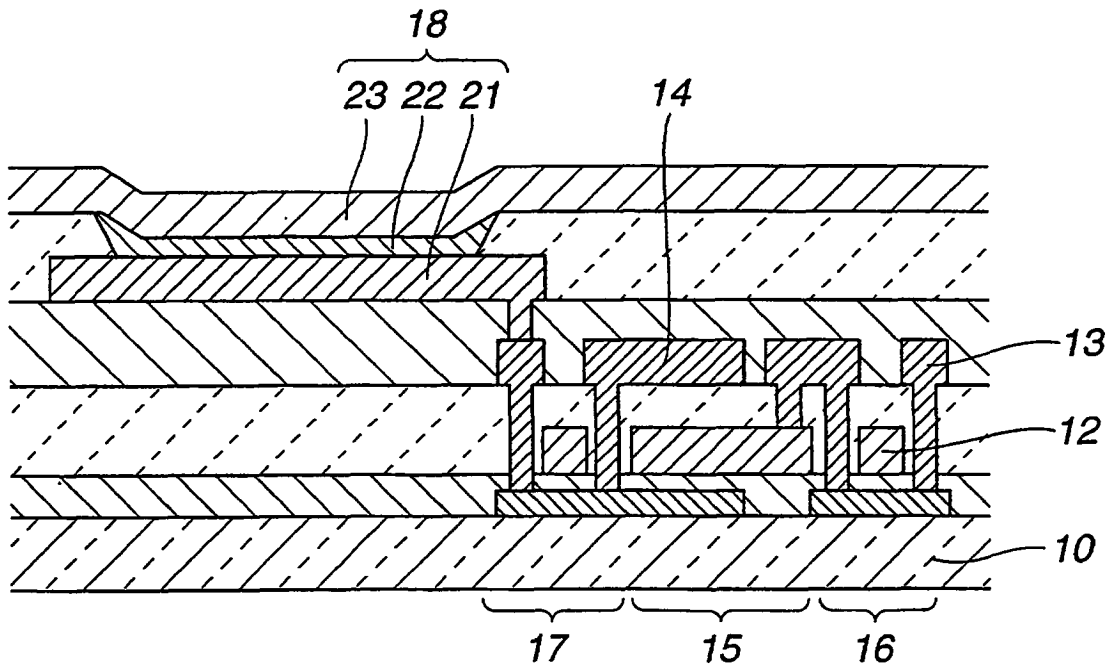


**FIG.3C**

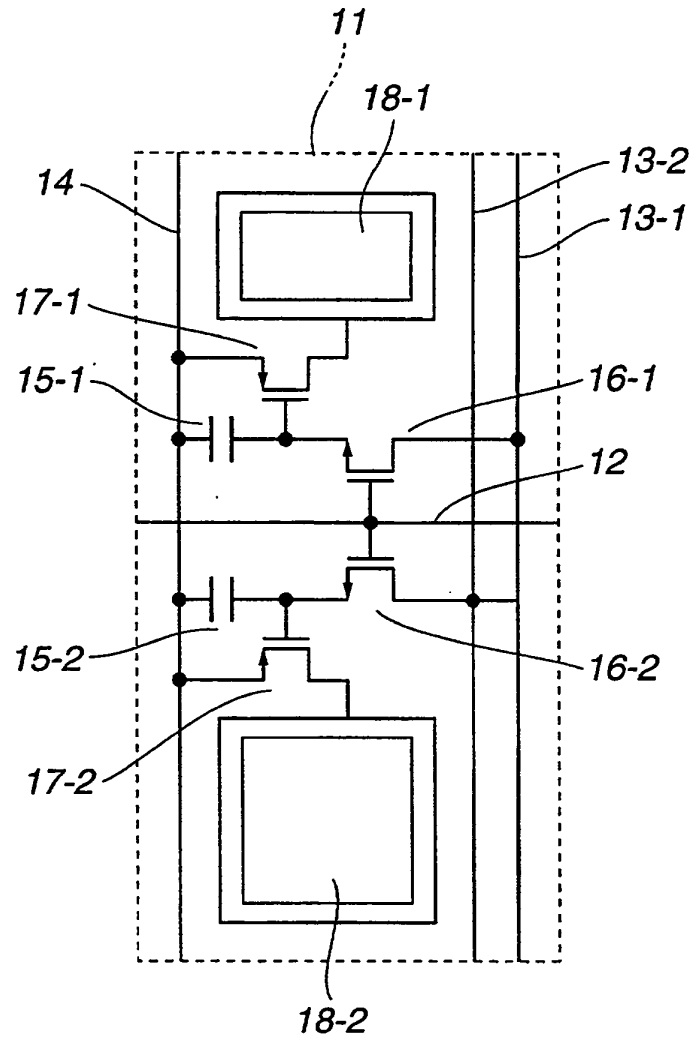
**FIG.3D**



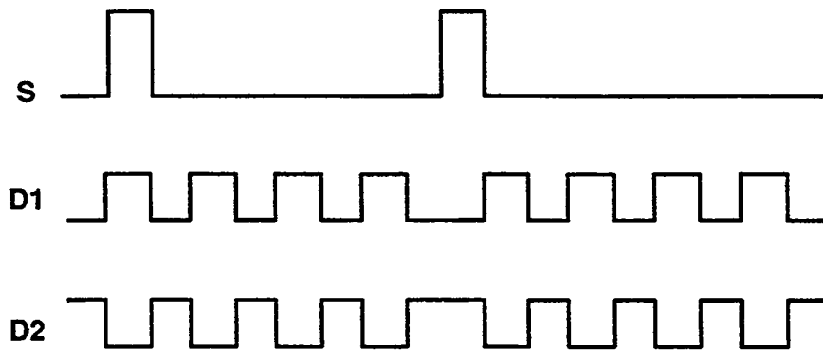
**FIG.4**



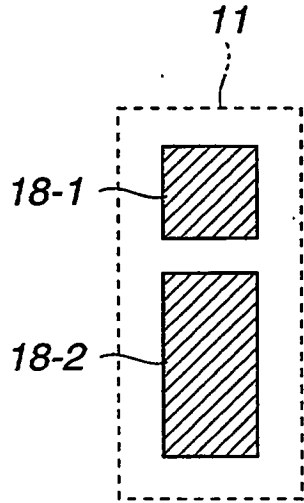
**FIG.5**



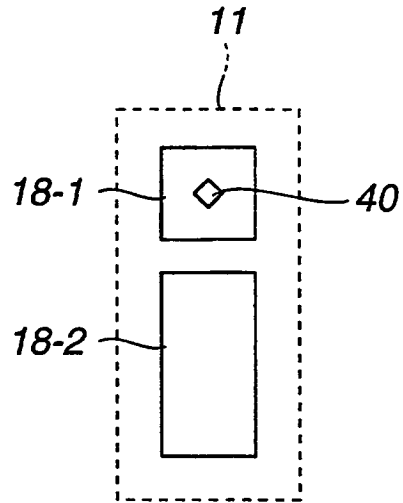
**FIG.6**



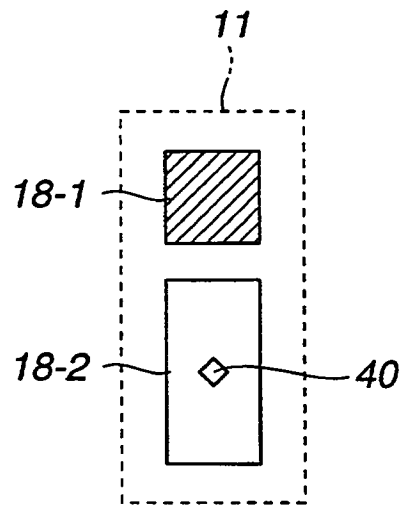
**FIG.7**



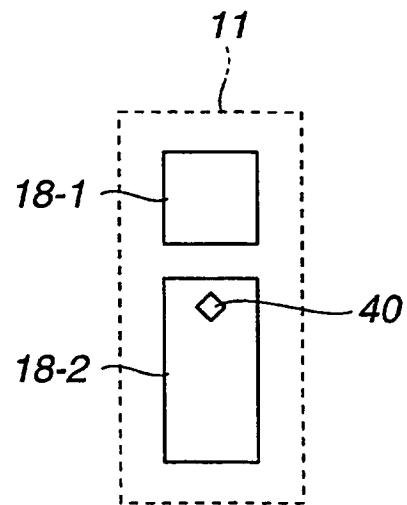
**FIG. 8A**



**FIG. 8B**



**FIG. 8C**



**FIG. 8D**

**REFERENCES CITED IN THE DESCRIPTION**

*This list of references cited by the applicant is for the reader's convenience only. It does not form part of the European patent document. Even though great care has been taken in compiling the references, errors or omissions cannot be excluded and the EPO disclaims all liability in this regard.*

**Patent documents cited in the description**

- JP HEI1173158 B [0007]
- GB 2217089 A [0011]
- EP 0671649 A [0012]

专利名称(译)	具有灰度控制的有源矩阵电致发光显示器		
公开(公告)号	<a href="#">EP1024473B1</a>	公开(公告)日	2008-08-13
申请号	EP2000300608	申请日	2000-01-27
[标]申请(专利权)人(译)	精工爱普生株式会社		
申请(专利权)人(译)	SEIKO EPSON CORPORATION		
当前申请(专利权)人(译)	SEIKO EPSON CORPORATION		
发明人	KIMURA, MUTSUMI, SEIKO EPSON CORPORATION		
IPC分类号	G09G3/32 G09G3/30 G09F9/30 G09F13/00 G09G3/20 H01L27/32		
CPC分类号	G09G3/3258 G09G3/2074 G09G3/30 G09G2300/0842 G09G2310/0262 G09G2320/0247		
优先权	1999336265 1999-11-26 JP 1999021624 1999-01-29 JP		
其他公开文献	EP1024473A3 EP1024473A2		
外部链接	<a href="#">Espacenet</a>		

摘要(译)

对应于每个灰度的发光部分围绕设置在中心的预定位置彼此对称地布置，从而形成包括多个发光元件的单位像素元件。这种结构允许提供一种显示装置，其中发光中心不会因每个灰度而移位。因此，当改变显示图像的亮度时，不会发生显示位置的不利移动。因此，本发明解决了与图像质量有关的缺陷，例如图像的闪烁，或者对观看者造成的不自然显示或疲劳的印象。

