

(19) World Intellectual Property  
Organization  
International Bureau



(43) International Publication Date  
19 August 2004 (19.08.2004)

PCT

(10) International Publication Number  
**WO 2004/070840 A1**

- (51) International Patent Classification<sup>7</sup>: **H01L 27/00**
- (21) International Application Number:  
PCT/NL2003/000937
- (22) International Filing Date:  
24 December 2003 (24.12.2003)
- (25) Filing Language: Dutch
- (26) Publication Language: English
- (30) Priority Data:  
1022269 24 December 2002 (24.12.2002) NL
- (71) Applicant (for all designated States except US): **OTB GROUP B.V.** [NL/NL]; Luchthavenweg 10, NL-5657 EB Eindhoven (NL).
- (72) Inventors; and
- (75) Inventors/Applicants (for US only): **BRIËR, Peter** [NL/NL]; Barneveldstraat 17, NL-5651 AD Eindhoven (NL). **EVERS, Marinus, Franciscus, Johanus** [NL/NL]; Ginderover 33, NL-5591 JM Heeze (NL).
- (74) Agent: **PRINS, A.W.**; C/o Vereenigde, Nieuwe Parklaan 97, NL-2587 BN The Hague (NL).
- (81) Designated States (national): AE, AG, AL, AM, AT (utility model), AT, AU, AZ, BA, BB, BG, BR, BW, BY, BZ, CA, CH, CN, CO, CR, CU, CZ (utility model), CZ, DE (utility model), DE, DK (utility model), DK, DM, DZ, EC, EE (utility model), EE, EG, ES, FI (utility model), FI, GB, GD, GE, GH, GM, HR, HU, ID, IL, IN, IS, JP, KE, KG, KP, KR, KZ, LC, LK, LR, LS, LT, LU, LV, MA, MD, MG, MK, MN, MW, MX, MZ, NI, NO, NZ, OM, PG, PH, PL, PT, RO, RU, SC, SD, SE, SG, SK (utility model), SK, SL, SY, TJ, TM, TN, TR, TT, TZ, UA, UG, US, UZ, VC, VN, YU, ZA, ZM, ZW.
- (84) Designated States (regional): ARIPO patent (BW, GH, GM, KE, LS, MW, MZ, SD, SL, SZ, TZ, UG, ZM, ZW), Eurasian patent (AM, AZ, BY, KG, KZ, MD, RU, TJ, TM), European patent (AT, BE, BG, CH, CY, CZ, DE, DK, EE, ES, FI, FR, GB, GR, HU, IE, IT, LU, MC, NL, PT, RO, SE, SI, SK, TR), OAPI patent (BF, BJ, CF, CG, CI, CM, GA, GN, GQ, GW, ML, MR, NE, SN, TD, TG).
- Published:  
— with international search report

[Continued on next page]

(54) Title: METHOD FOR MANUFACTURING AN ORGANIC ELECTROLUMINESCENT DISPLAY DEVICE, SUBSTRATE TO BE USED WITH SUCH A METHOD AND AN ORGANIC ELECTROLUMINESCENT DISPLAY DEVICE OBTAINED WITH THE METHOD

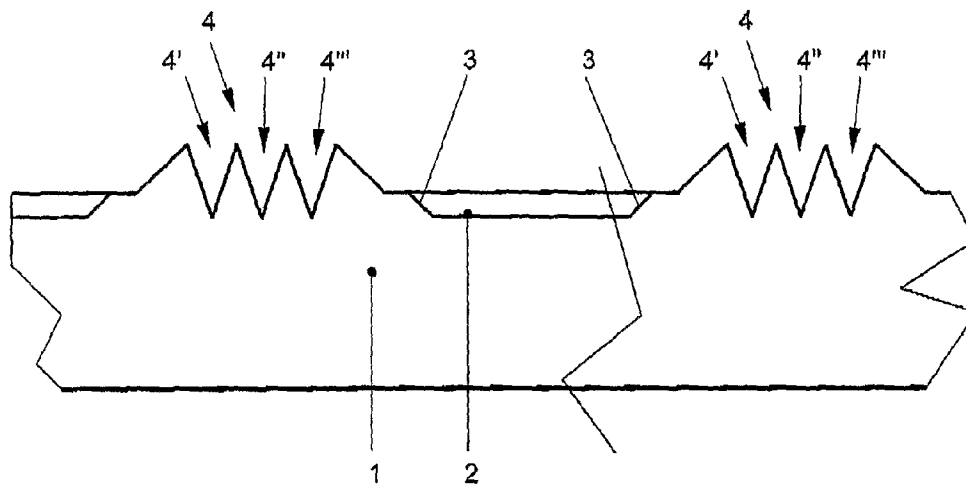

(57) Abstract: A method for manufacturing an organic electroluminescent display device, wherein an arrangement of layers is applied to a substrate such, that in a first direction, first conductors extend as well as in a second direction, while between the intersections of the conductors an organic electroluminescent connection has been provided which, under the influence of an electric tension, emits light, the substrate being manufactured from plastic and being provided with a surface structure which forms a boundary for at least a number of the layers to be applied. The invention also provides a substrate intended for use in a method according to the invention for manufacturing an organic electroluminescent display device, wherein the substrate has been manufactured from plastic and is provided with a surface structure which forms a boundary for at least a number of the layers to be applied. The invention further provides an organic electroluminescent display device obtained with the method.

WO 2004/070840 A1



---

*For two-letter codes and other abbreviations, refer to the "Guidance Notes on Codes and Abbreviations" appearing at the beginning of each regular issue of the PCT Gazette.*

Title: Method for manufacturing an organic electroluminescent display device, substrate to be used with such a method and an organic electroluminescent display device obtained with the method.

The invention relates to a method for manufacturing an organic electroluminescent display device, wherein an arrangement of layers is applied to a substrate, such that, in a first direction, conductors extend, as well as in a second direction, while between the intersections of the conductors, an organic  
5 electroluminescent connection is provided which emits light under the influence of an electric tension.

The invention also relates to a substrate suitable and intended for use in a method according to the invention for manufacturing an organic electroluminescent display device.

10 With the known method for manufacturing an organic electroluminescent display device, the starting point is a substrate manufactured from glass, onto which a structure has been applied with the aid of a photoresist, provided, for instance, through spin coating, which photoresist has been locally exposed and thereupon has been locally removed with  
15 washing techniques. These processes are laborious, cost much time and hence are costly. As, in the manufacture of displays, it is the very cost price which plays a predominant part, the provision of a display device wherein such "wet" chemical steps for manufacturing the display device are omitted would be of great advantage.

20 To this end, according to the invention, the method of the type described in the opening paragraph is characterized in that the substrate is manufactured from plastic and is provided with a surface structure which forms a boundary, at least for a number of the layers to be applied.

Such a plastic substrate which is provided with a surface structure  
25 can be manufactured with a plastic designing process known per se such as, for instance, injection molding, embossing, photopolymeric replication or the

like. Embossing has been described in, for instance, US-A-4 659 407, photopolymeric replication has been described in WO 87/02934. From, for instance, the manufacture of CDs, injection molding techniques are known with the aid of which very fine submicronstructures can be manufactured in a plastic substrate at relatively very low cost prices. The need of using wet chemical techniques for forming the substrate is thereby cancelled with all associated advantages. Such fine surface structures can also be applied on a film, as is described in, for instance, WO 99/12160 or EP-A-0 408 283.

According to a further elaboration of the method, a first conductive layer can be applied by means of a layer application process such as, for instance, a sputtering process, wherein the surface structure of plastic substrate is provided with a shadowing structure which is such that with the layer application process, parts of this shadowing process are hardly covered, if at all, with the respective conductive layer.

The shadowing structure must be such that the electrical resistance prevailing there is great relative to the resistance in the rest of the conductive layer.

According to still a further elaboration of the invention, the shadowing structure can comprise a number of parallel, narrow and deep grooves, while the width and the depth of the grooves are such that, in the layer application process, at least a part of the side walls and/or the bottom of these grooves is hardly covered, if at all, with the first conductive layer.

Such a groove structure can be designed to be such that, in a releasing manner, it can be taken from the mold in which the plastic substrate is formed. In the designing process of the plastic substrate, the shadowing structure is provided without, to that end, one single finishing step being required for the plastic substrate. Basically, the shadowing structure is obtained practically free of charge in the designing process of the plastic substrate when the mold has the right shape.

According to still another elaboration of the invention, layers can be applied with the aid of a printing operation such as, for instance, inkjet printing, silkscreen printing, electrostatic printing techniques and thermal transfer printing. In order to somewhat simplify the printing process, it can be advantageous to design the surface structure of the substrate to be such that, as it were, channels have been provided herein in which the liquids dispensed through the printing process are deposited. The walls of the respective channels form the boundaries of the liquid deposited in the channels with the printing process.

Subsequently, with printing techniques, layer application techniques such as sputtering, CVD and PECVD-techniques, layers and layer patterns can be provided with the aid of which the organic electroluminescent display device is composed. Such layers and layer patterns comprise, for instance, a PDOT- and PPV- layer in the pixel pits or sub-pixel pits, insulating layers for covering the first conductor and conductive layers for forming a number of second conductors.

According to a further elaboration of the invention, optionally, with a curing varnish, an additional relief structure can be applied to the substrate already provided with a number of layers, for forming a relief structure desired for the application of a following layer. For instance, in a simple manner, a number of new channels can be formed in which the liquid, forming the second conductors, can be deposited. This curing varnish can for instance be a UV-curing varnish which is deposited locally with an inkjet printing operation. In such a manner, for instance, also the above-described shadowing structure can be removed by filling the relatively narrow and deep grooves up with UV-curing varnish.

According to an alternative, further elaboration of the invention, after application of at least one layer, the shape of the surface structure can be adapted through a transforming technique, such as, for instance, a local thermal treatment. Such a thermal treatment can, for instance, be

contactlessly, via infrared radiation, or laser irradiation or with a contact treatment. Thus, for instance, the groove-shaped shadowing structures can be melted away.

According to the invention, the substrate described in the opening  
5 paragraph is characterized in that it is manufactured from plastic and is provided with a surface structure which forms a boundary, at least for a number of the layers to be applied.

Such a plastic substrate provided with a surface structure can be manufactured in one single operation in an injection molding process. This  
10 means that the cost price of the substrate can be particularly low. This in contrast with the substrates from glass used heretofore, on which, with the aid of photochemical techniques, structures have been applied.

According to a further elaboration of the invention, the surface structure can comprise a number of pixel pits or sub-pixel pits. Such pits  
15 render the deposition of liquid therein, such as for instance PDOT or PPV, with the aid of an inkjet process simple and more controllable.

Further, the surface structure can comprise a shadowing structure which is such that with a sputtering process, indirect sputting and/or  
20 evaporation, parts of this shadowing structure are not covered with the respective conductive layer, so that the shadowing structure forms insulating tracks in the conductive layer. According to a further elaboration of the invention, the shadowing structure can be formed by a number of parallel narrow and deep grooves, while the width and the depth of the grooves is such that at least a part of the side walls and/or the bottom of these grooves are not  
25 covered with a first conductive layer in a sputtering process.

According to still a further elaboration of the invention, in the pixel pits or sub-pixel pits, a structure can be provided which influences the generated light that passes the structure. Such a structure can also be provided at the side of the substrate remote from the pixel pits or sub-pixel  
30 pits. For instance, a structure in the form of a Fresnel lens, having a

converging or diverging effect on the light passing through the structure, can be considered.

Further, according to a further elaboration of the invention, in the pixel pits or sub-pixel pits, a structure can be provided which is designed for improving the distribution of liquid for forming the layers applied in the pixel pits or sub-pixel pits. It is noted that such structures, improving the distribution of liquid, can also be provided in the channels in which, through printing techniques, liquids are deposited, for a better distribution of the liquid.

According to a further elaboration of the invention, a contact surface enlarging structure can be provided in the pixel pits or sub-pixel pits. Firstly, such a contact surface enlarging structure yields a larger conductive surface so that the electrical resistance across a pixel is reduced. Moreover, a larger electroluminescent surface is created so that a greater light intensity per pixel is obtained. Optionally, the structure improving the distribution of liquid can also be combined with the contact surface enlarging structure. The structure can, for instance, comprise a number of capillary grooves.

The invention also provides an organic electroluminescent display device manufactured while using a method according to any one of claims 1 - 30 starting from a substrate according to any one of claims 31 - 44.

Figs. 1 - 18 show the various steps of building up a first embodiment of a display device according to the invention while the Figures with the uneven Figure numbers show cross-sectional views and the Figures with even Figure numbers show top plan views;

Figs. 19 - 36 show the various steps of building up a second embodiment of a display device according to the invention, while the Figures with uneven Figure numbers show cross-sectional views and the Figures with even Figure numbers show top plan views;

Fig. 37 shows a top plan view of the substrate, wherein a first structure which has been applied in a pixel pit is shown;

Fig. 38 shows a top plan view of the substrate, wherein a second structure which has been applied in a pixel pit is shown;

Fig. 39a shows a substrate with a shadowing structure provided therein; and

5 Fig. 39b shows in which manner this shadowing structure can be locally removed through a thermal laser operation.

Figs. 1 and 2 show a cross-sectional front view and a top plan view of a part of a plastic substrate 1 not yet provided with layers for manufacturing an organic electroluminescent display device. During the manufacture of the substrate, for instance with the aid of an injection molding operation, the substrate has been provided with a surface structure forming a boundary, at least for a number of the layers to be applied. For instance, pixel pits 2 are clearly visible which are bounded by pixel pit boundaries 3. The surface structure further comprises a shadowing structure 4. In the present exemplary embodiment, the shadowing structure has been designed as, each time, a number of parallel, deep, narrow grooves 4', 4'', 4'''. Such a shadowing structure is such that a layer to be applied with a layer application process such as, for instance, sputtering, hardly covers, if at all, parts of the shadowing structure.

20 Figs. 3 and 4 shows the same substrate which is provided with a transparent encapsulation layer 5, such as, for instance, a nitride-oxide-nitride-, or, NON-layer. Also, other transparent layers which are tight to water, oxygen and other undesired substances are among the possibilities. The transparent encapsulation layer can, for instance, be applied with a deposition technique such as a PVD-, CVD- or PECVD-process.

Figs. 5 and 6 show the substrate after a first conductive layer 6 has been applied. Such layers can be applied with, for instance, a sputtering process. In the present exemplary embodiment, the first conductive layer is formed by a TCO-layer (transparent conductive oxide). Also, other conductive layers can be applied. It is clearly visible that the deep parts of the grooves 4',

4", 4'" are hardly covered, if at all, with the first conductive layer 6. In this manner therefore, parallel conductive paths are obtained insulated from each other and extending in a first direction. The Figures also clearly show that parts of the first conductors extend in pixel pits or sub-pixel pits 2 of the surface structure of the substrate 1. The first conductive layer can also be a so-called PDOT-layer. However, it is also possible that a hole injecting layer 7, such as, for instance, a PDOT-layer is applied exclusively in the pixel pits or sub-pixel pits 2. With this last-mentioned option, which is represented in Figs. 7 and 8, the layer can for instance be deposited in the pixel pits or sub-pixel pits with a printing operation, such as for instance an inkjet operation. Since the pixel pits or sub-pixel pits 2 are bounded by pixel pit boundaries 3, the risk of the liquid forming the PDOT-layer flowing outside the pixel pits or sub-pixel pits 2 is reduced to a minimum.

Thereupon, in Figs. 9 and 10, it is shown that in the pixel pits or sub-pixel pits 2, further, a light emitting layer 8 is deposited, such as, for instance, a PPV-layer. This layer too can be provided with the aid of, for instance, inkjet printing.

Figs. 11 and 12 show that the shadowing structure 4 and, more in particular, the deep, narrow grooves 4', 4", 4'" are filled up with an insulating covering 9. This covering can for instance be formed by a UV-curing varnish which can be accurately applied with the aid of an inkjet printing operation. Instead thereof, the method represented in Fig. 39b can also be used.

Then, as shown in Figs. 13 and 14, the entire substrate 1 is covered with a layer of barium 10, whereupon, as shown in Figs. 15 and 16, a second conductive layer 11 is applied such that a number of parallel conductors 12 is provided, extending in a second direction and which are mutually insulated from each other. Parts of the second conductors 12 extend in pixel pits or sub-pixel pits 2 of the surface structure of the substrate 1. In the present exemplary embodiment, the second conductors 12 extend perpendicularly to the first conductors which extend between the parallel shadowing structures 4.

The second conductive layer 11 too can be selectively applied with the aid of a printing process, such as for instance an inkjet printing operation.

Finally, Figs. 17 and 18 show that a second encapsulation layer 13 is applied over the entire substrate. This layer too seals off from undesired  
5 substances, such as, for instance, water, oxygen and the like.

Figs. 19 and 20 show a second embodiment of a substrate 21. In contrast to the first exemplary embodiment, this substrate has not been provided with a shadowing structure as described hereinabove. Instead thereof, a channel structure 24 with channel boundary 24' is present for a  
10 printable first conductive layer. Also, the pixel pits or sub-pixel pits 22 are clearly visible with the pixel pit boundaries 23. Further, a separating structure 25 is already partially present for a printable second conductive layer. This separating structure 25 is still interrupted at the location of the channels 24 in which the first conductive layer 27 is to be printed.

15 Figs. 21 and 22 show the same substrate which is provided with a transparent encapsulation layer 26, such as, for instance, nitride-oxide-nitride, or NON-layer. Also, other transparent layers which are tight to water, oxygen and other undesired substances are among the possibilities. The transparent encapsulation layer 26 can, for instance, be applied through an evaporation  
20 technique such as a CVD- or PECVD-process.

Figs. 23 and 24 show a printed first conductive layer 27. It is clearly visible that the first conductive layer 27 extends in the channel structure 24 intended thereto and in the pixel pits or sub-pixel pits 12. In the present exemplary embodiment, the first conductive layer 27 is formed by a PDOT-  
25 layer which has been provided on the desired location with the aid of an inkjet printing operation. The channel structure boundary 24' and the pixel pit boundary 23 ensure that the liquid does not flow outside the desired areas.

Figs. 25 and 26 show that in the pixel pits or sub-pixel pits 22, further, a light emitting layer 28 is deposited, such as, for instance, a PPV-  
30 layer. This layer 28 too can be provided with for instance inkjet printing.

In Figs. 27 and 28 it is shown that across the channel structure 24, an insulating covering 29 has been provided. The insulating covering 29 can for instance be formed by a UV-varnish or photoresist varnish.

Figs. 29 and 30 show that the separating structure 25 has also been provided in the channel structure 24 through the provision of a threshold 30 therein. The additional relief structure is therefore provided on the substrate already provided with a number of layers for forming a relief structure desired for applying a following layer. In the present exemplary embodiment, the additional relief structure 30 is provided with the aid of a printing operation, while using a curing varnish, for instance a UV-curing varnish. Thus, channels 31 are formed, extending parallel to each other, while the channel direction is perpendicular to the first direction mentioned in which the first conductors 27 extend.

Figs. 31 and 32 show that, thereupon, the entire substrate is covered with an electron injecting layer 32 such as, for instance, a calcium-, magnesium-, lithium fluoride- or barium-layer.

Subsequently, Figs. 33 and 34 show that the second conductive layer 33 has been provided in the channels 31, for instance with the aid of an inkjet printing operation. The second conductive layer 33 provides a number of parallel conductors, mutually insulated from each other and extending in the second direction, while parts of the second conductors extend in pixel pits or sub-pixel pits 22 of the surface structure of the substrate 21.

Finally, Figs. 35 and 36 show that after the application of the second conductive layer, an encapsulation layer 34 is applied over substantially the entire surface of the substrate. This layer too seals off from undesired substances such as, for instance, water, oxygen and the like. The layer can comprise, for instance, a Nitride-metal-Nitride layer, a NONON-layer or a NDLCN-layer (nitride diamond like carbon nitride).

Fig. 37 shows a top plan view of a substrate wherein, in the pixel pits or sub-pixel pits, a structure 35 has been provided which influences the

generated light passing the structure. In Fig. 37, the structure forms a Fresnel lens 35 which has a converging, diverging or, conversely, paralleling effect. It is noted that such a structure can also extend over several pixels, so that in a part of the eventual display, the issuing light is optically influenced. Such a structure can also be provided on the side of the substrate remote from the pixel pits.

Fig. 38 shows another structure 36 provided in the pixel pits or sub-pixel pits 2, 22, designed to improve the distribution of liquid for forming layers provided in the pixel pits or sub-pixel pits. Preferably, this structure 36 also has a contact surface enlarging effect. This can, for instance, be effected with a structure which is provided with capillary grooves. Such a larger contact surface not only reduces the electrical resistance, it also provides a larger light emitting surface, so that, also, more light is generated.

Figs. 39a shows, in cross section, once more, a substrate 1 with a shadowing structure 4. In Fig. 39b, it is shown how this structure can be melted away locally with the aid of a laser beam or infrared beam directed through a lens 37, which locally heats the shadowing structure 4 such that it melts, so that the shadowing structure 4 disappears.

It is clear that the invention is not limited to the exemplary embodiments described but that various modifications are possible within the framework of the invention as defined in the claims.

Claims

1. A method for manufacturing an organic electroluminescent display device, wherein an arrangement of layers is applied to a substrate such, that in a first direction, first conductors extend as well as in a second direction, while between the intersections of the conductors an organic  
5 electroluminescent connection has been provided which, under the influence of an electric tension, emits light, the substrate being manufactured from plastic and being provided with a surface structure which forms a boundary for at least a number of the layers to be applied.
2. A method according to claim 1, wherein the manufacture of the  
10 substrate takes place with the aid of an injection molding process.
3. A method according to claim 2, wherein in the injection molding process use is made of an injection molding mold which is provided with a negative image of the desired surface structure of the substrate.
4. A method according to claim 1, wherein the manufacture of the  
15 substrate takes place with the aid of embossing, photopolymeric replication or a similar plastic designing process.
5. A method according to any one of the preceding claims, wherein after the manufacture of the plastic substrate, a first transparent encapsulation layer is applied to the substrate.
- 20 6. A method according to claim 5, wherein the first transparent encapsulation layer is a nitride-oxide-nitride layer (NON-layer).
7. A method according to claim 5 or 6, wherein this first transparent encapsulation layer is applied with the aid of a deposition technique, such as, for instance, a PVD-, CVD- or PECVD-process.
- 25 8. A method according to any one of claims 5 – 7, wherein after the application of the first transparent encapsulation layer, a first conductive layer is applied such that a number of parallel conductors extending in a first

direction is provided which are mutually insulated from each other, while parts of the first conductors extend in pixel pits or sub-pixel pits of the surface structure of the substrate.

9. A method according to claim 8, wherein the first conductive layer is applied by means of a layer application process, such as, for instance, a sputtering process, while the surface structure of plastic substrate is provided with a shadowing structure which is such that with the layer application process, parts of this shadowing structure are not covered with the respective conductive layer.

10. A method according to claim 9, wherein the shadowing structure comprises a number of parallel, narrow and deep grooves, the width and the depth of the grooves being such that at least a part of the side walls and/or the bottom of these grooves are hardly covered, if at all, with the first conductive layer in the sputtering process.

11. A method according to claim 8, wherein the first conductive layer is applied with the aid of a printing operation, such as for instance inkjet printing, silkscreen printing, electrostatic printing or thermal transfer printing.

12. A method according to any one of claims 8 – 11, wherein after the application of the first conductive layer, at least in the pixel pits or sub-pixel pits, a hole injecting layer such as for instance a PDOT-layer is applied.

13. A method according to claim 11, wherein the first conductive layer also forms a hole injecting layer in the pixel pits or sub-pixel pits, such as for instance a PDOT-layer.

14. A method according to any one of claims 12 or 13, wherein after application of the hole injecting layer a light emitting layer is provided locally in at least the pixel pits or sub-pixel pits, such as for instance a PPV-layer.

15. A method according to at least claim 8, wherein at least those parts of the first conductive layer which are not covered with a light emitting layer and which, in a following process step, will be covered by a second conductive

layer, are provided with an insulating covering prior to said following process step.

16. A method according to claim 15, wherein the insulating covering is applied with a printing operation, such as, for instance, by means of inkjet printing.
17. A method according to claim 16, wherein the insulating layer is formed from a UV-curing varnish.
18. A method according to claims 10 and 16 or claims 10 and 17, wherein the deep grooves forming the shadowing structure are filled up with the insulating covering.
19. A method according to any one of the preceding claims, wherein the shape of the surface structure, after application of at least one layer, is adapted by a transforming technique, such as, for instance, a local thermal treatment.
20. A method according to claim 19, wherein the local thermal treatment is carried out with the aid of a laser operation or with the aid of a local infrared irradiation.
21. A method according to any one of the preceding claims, wherein an additional relief structure is provided on the substrate already provided with a number of layers, for forming a relief structure desired for the application of a following layer.
22. A method according to claim 21, wherein the additional relief structure is provided with the aid of a printing operation, while using a curing varnish, preferably a UV-curing varnish.
23. A method according to claims 8 and 21 or claims 8 and 22, wherein after application of the insulator, a relief structure is provided for forming channels extending parallel to each other, while the channel direction is perpendicular to said first direction in which the first conductors extend.
24. A method according to claim 15, wherein after application of the insulating covering, a second conductive layer is provided such that in simple

manner, a number of parallel conductors are provided extending in a second direction and which are mutually insulated from each other, while parts of the second conductors extend in pixel pits or sub-pixel pits of the surface structure of the substrate.

- 5 25. A method according to claim 24, wherein the second direction is perpendicular to the first direction.
26. A method according to claim 24 or 25, wherein the second conductive layer is applied with a printing process, such as, for instance, inkjet printing, silkscreen printing, electrostatic printing or thermal transfer printing.
- 10 27. A method according to claim 23 and any one of claims 24 – 26, wherein the second conductive layer is applied in said channels extending parallel to each other.
28. A method according to any one of claims 24 – 27, wherein, prior to the application of the second conductive layer and after the application of the  
15 insulating covering, an electron injecting layer such as a calcium, magnesium, lithium fluoride or barium layer is applied to the substrate.
29. A method according to claim 28, wherein the barium layer is applied with a PVD-process.
30. A method according to any one of claims 24 – 27, wherein after the  
20 application of the second conductive layer at least one encapsulation layer is applied.
31. A substrate suitable and intended for use in a method according to any one of the preceding claims for manufacturing an organic  
electroluminescent display device, wherein the substrate has been  
25 manufactured from plastic and has been provided with a surface structure forming a boundary for at least a number of the layers to be applied.
32. A substrate according to claim 31, wherein the surface structure comprises a number of pixel pits or sub-pixel pits.
33. A substrate according to claim 31 or 32, wherein the surface  
30 structure comprises a shadowing structure which is such that with a

sputtering process, parts of this shadowing structure are not covered with the respective conductive layer.

34. A substrate according to claim 33, wherein the shadowing structure comprises a number of parallel, narrow and deep grooves, wherein the width  
5 and the depth of the grooves is such that at least a part of the side walls and/or the bottom of these grooves are not covered with the first conductive layer in the sputtering process.

35. A substrate according to any one of claims 31 – 34, wherein the surface structure is releasing such that it can be taken from a mold which is  
10 provided with a negative image of the surface structure.

36. A substrate according to any one of claims 31 – 35, wherein the substrate is an injection molding product.

37. A substrate according to any one of claims 31 – 36, wherein, in the pixel pits or sub-pixel pits, a structure has been provided which influences the  
15 generated light passing the structure.

38. A substrate according to any one of claims 31 – 36, wherein at the side of the substrate remote from the pixel pits or sub-pixel pits, a structure has been provided which influences the generated light passing the structure.

39. A substrate according to claim 37 or 38, wherein the structure  
20 comprises a Fresnel lens.

40. A substrate according to any one of claims 37 – 39, wherein the structure has a converging effect on the light issuing through the structure.

41. A substrate according to any one of claims 37 – 39, wherein the structure has a diverging effect on the light issuing through the structure.

25 42. A substrate according to any one of claims 31 – 41, wherein in the pixel pits or sub-pixel pits a structure has been provided, designed for improving the distribution of liquid for forming the layers provided in the pixel pits or sub-pixel pits.

43. A substrate according to any one of claims 31 – 42, wherein in the pixel pits or sub-pixel pits a contact surface enlarging structure has been provided.

44. A substrate according to any one of claims 42 or 43, wherein the  
5 structure comprises capillary grooves.

45. An organic electroluminescent display device manufactured while using a method according to any one of claims 1 – 30 starting from a substrate according to any one of claims 31 – 44.

1/20

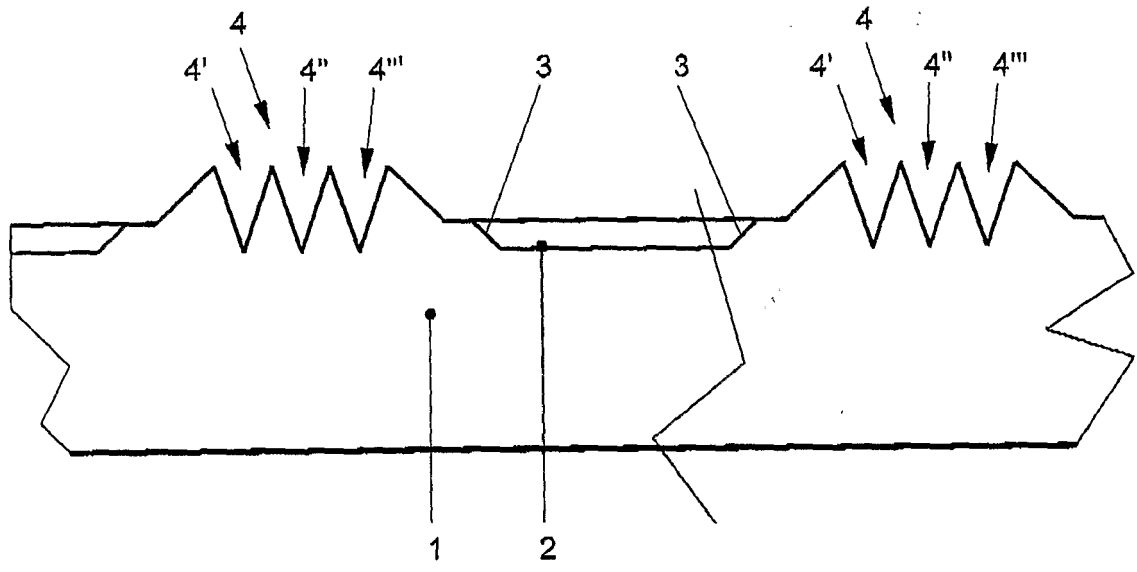

Fig. 1

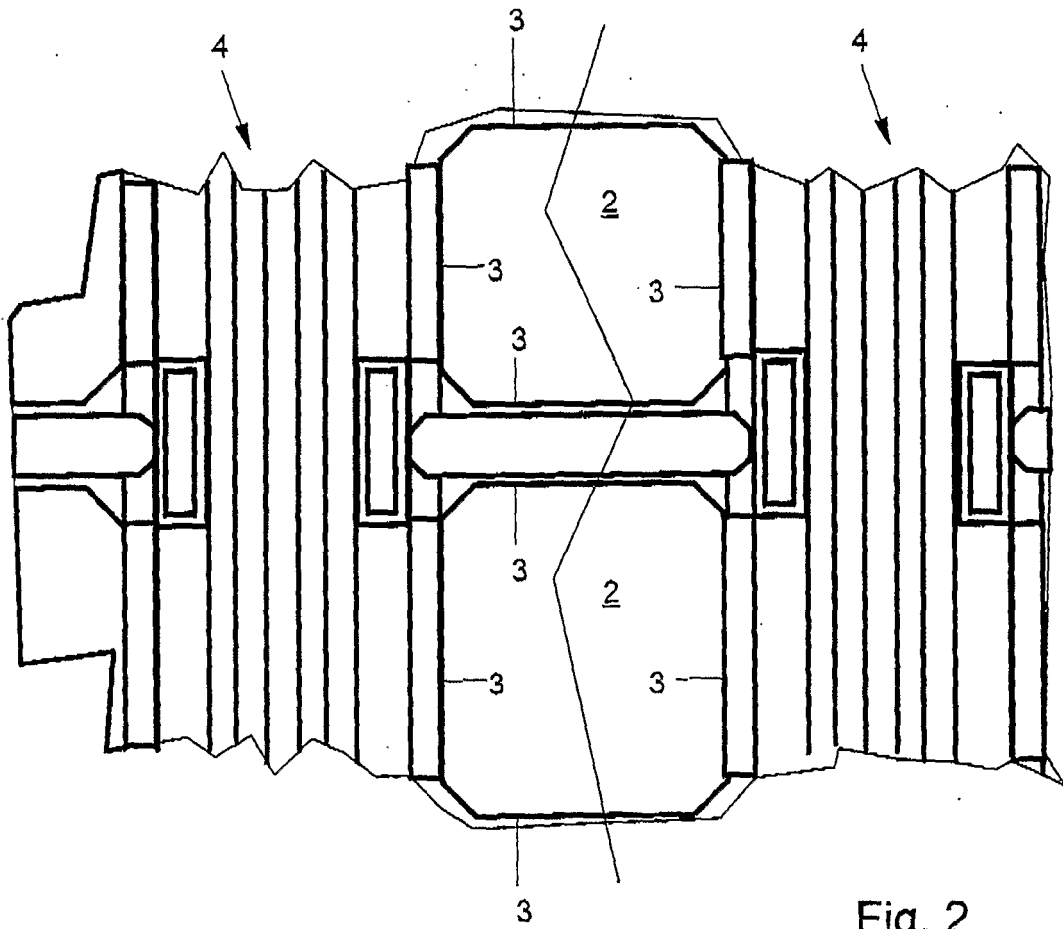

Fig. 2

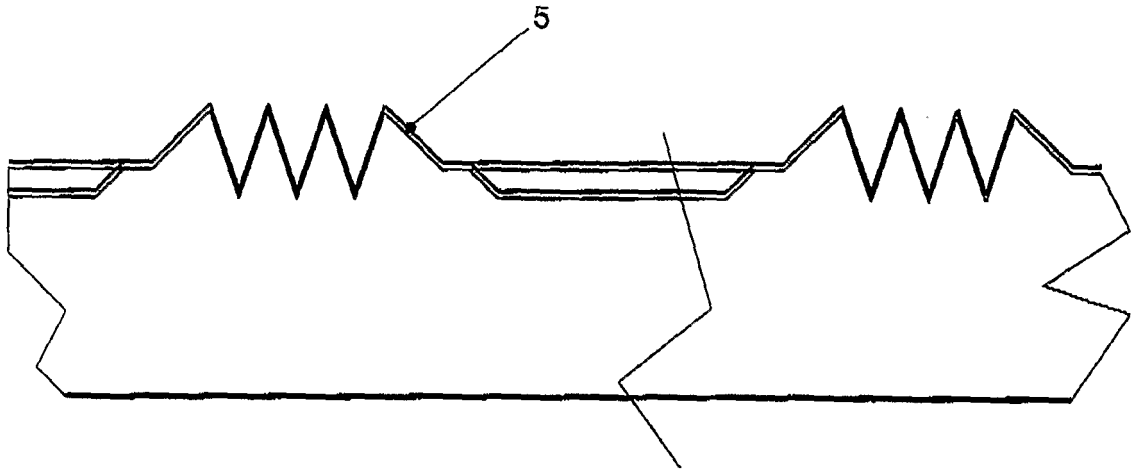

Fig. 3

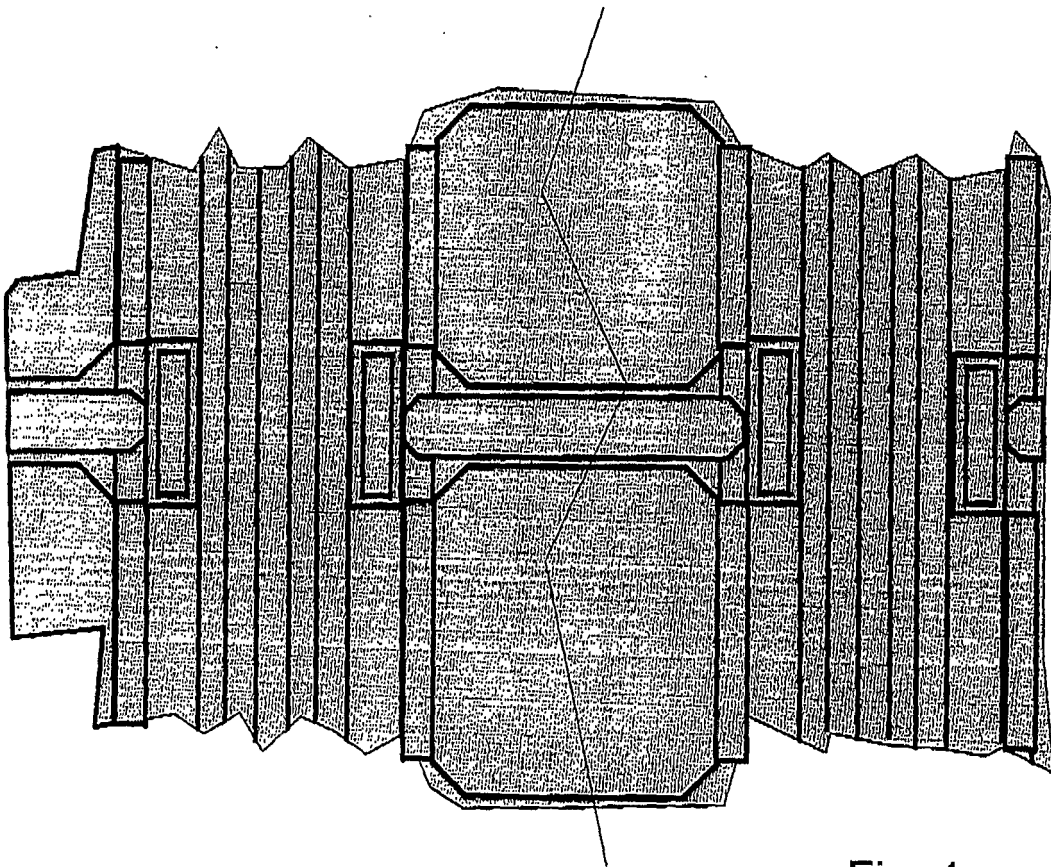

Fig. 4

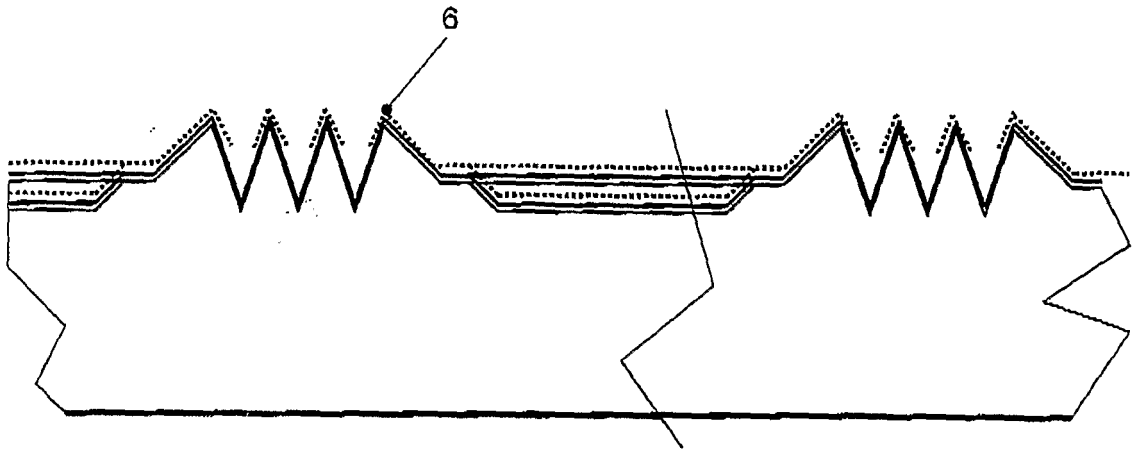

Fig. 5

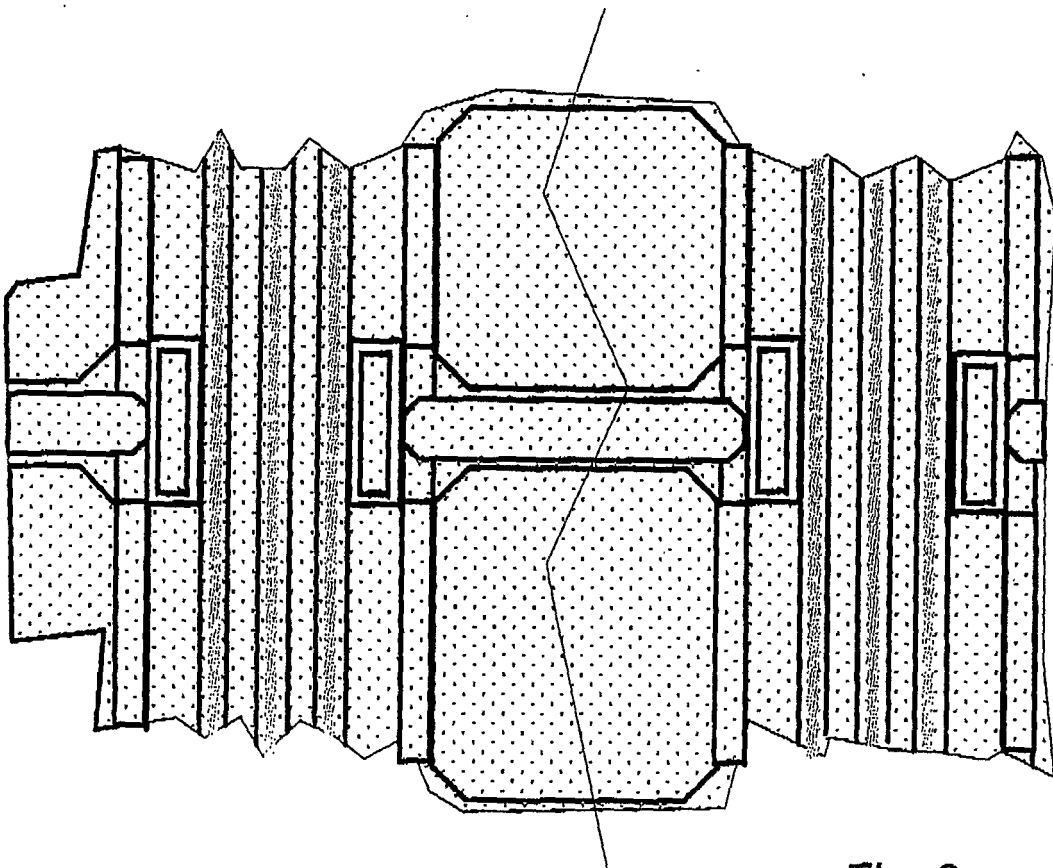

Fig. 6

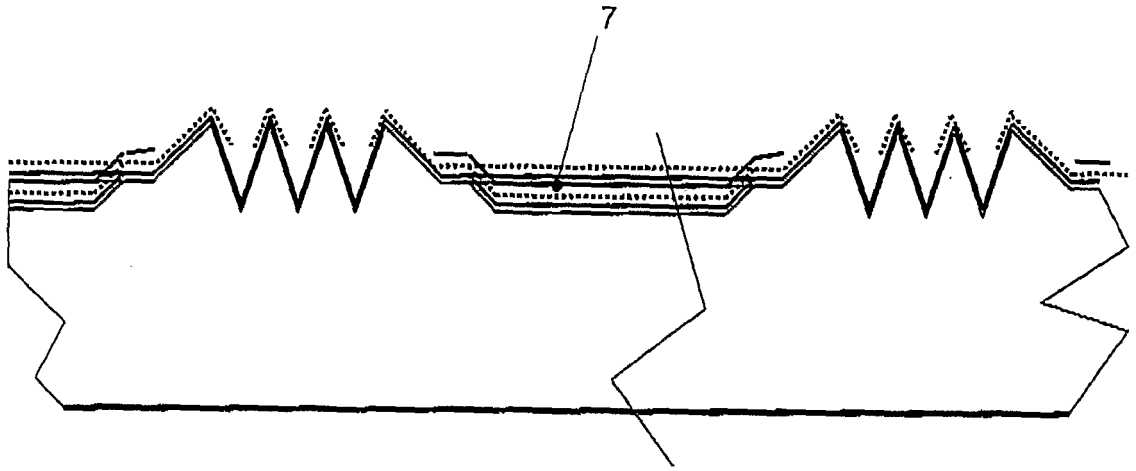

Fig. 7

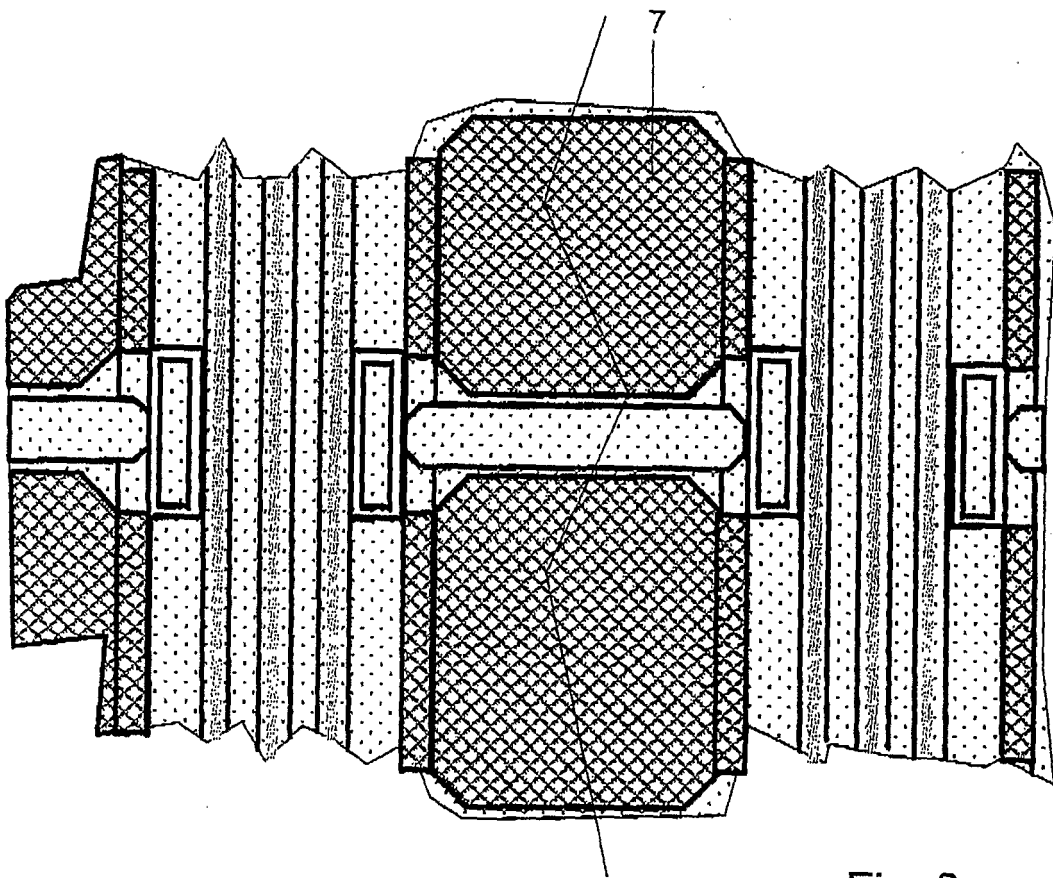

Fig. 8

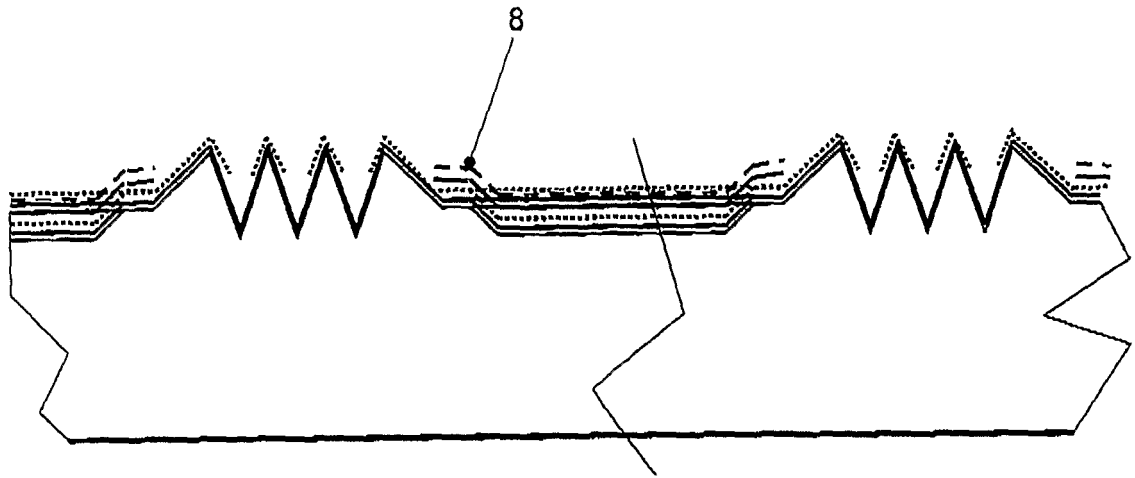

Fig. 9

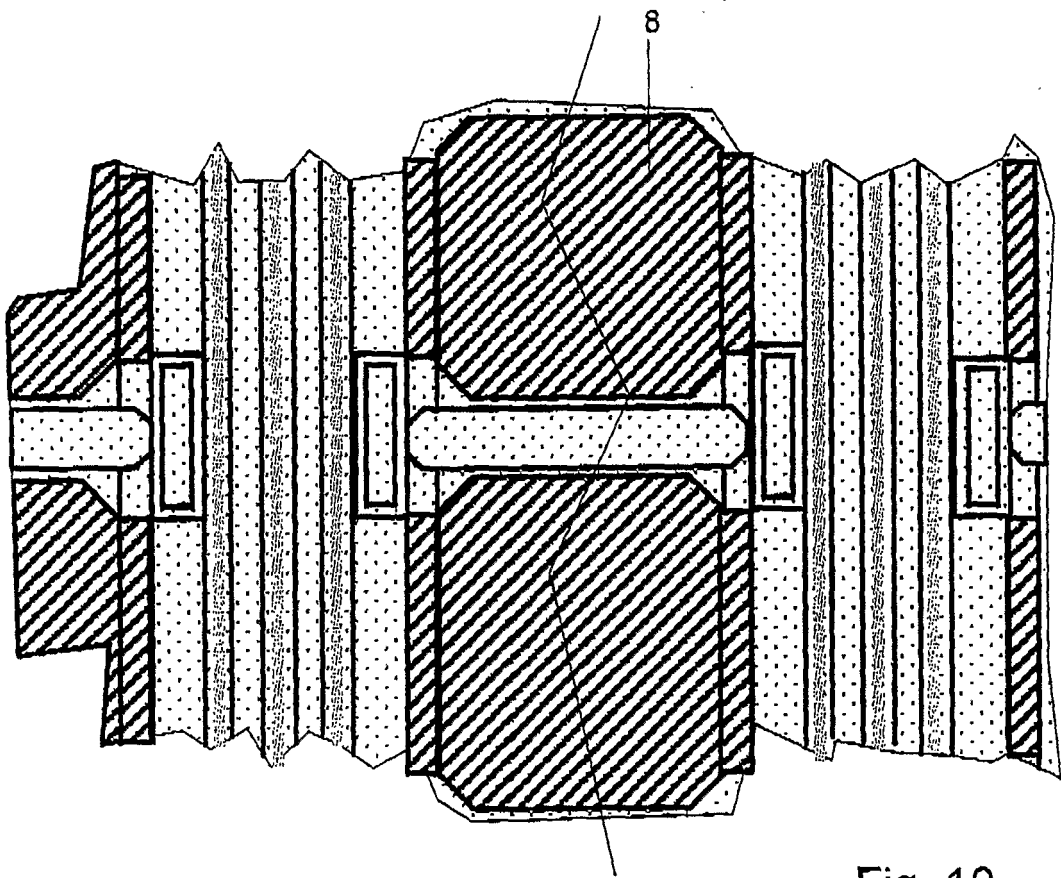

Fig. 10

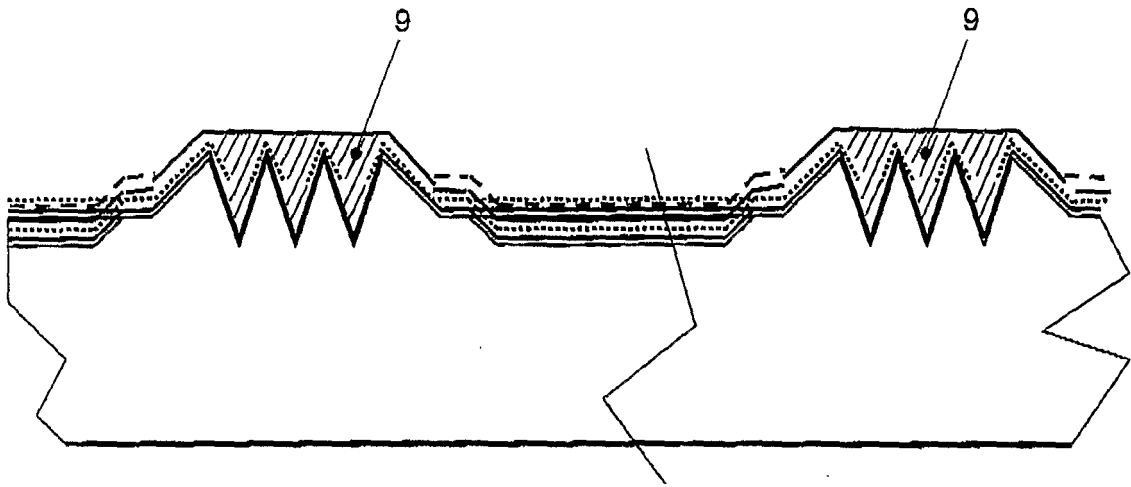

Fig. 11

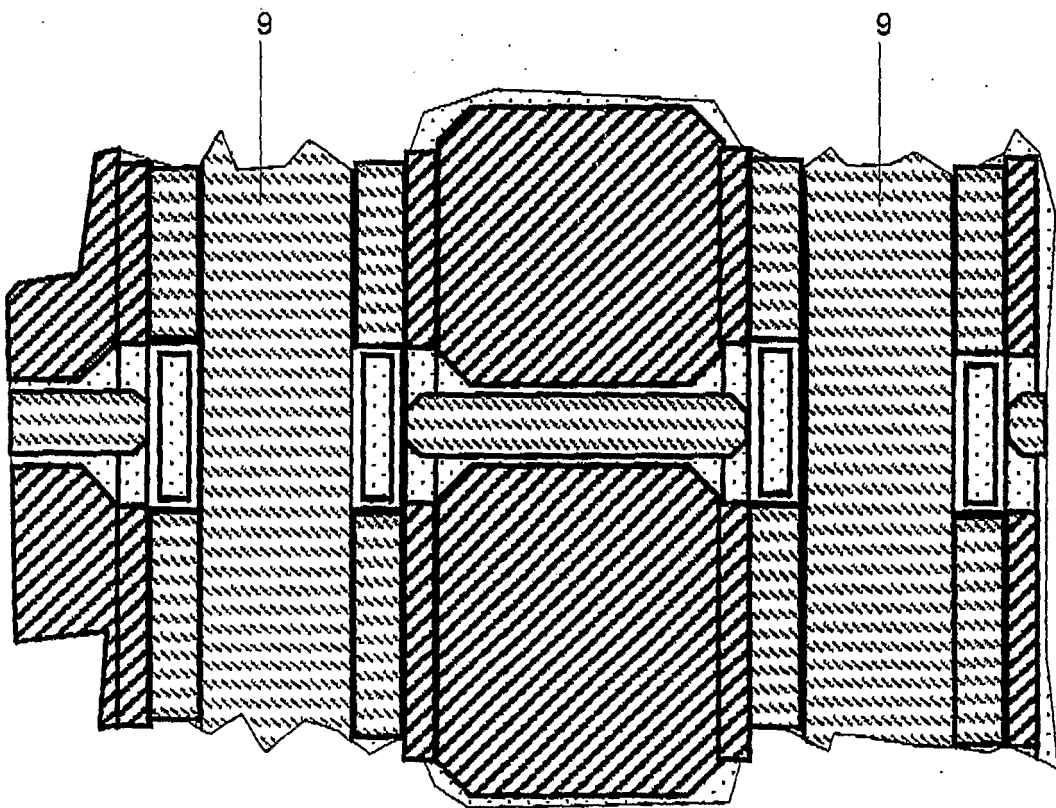

Fig. 12

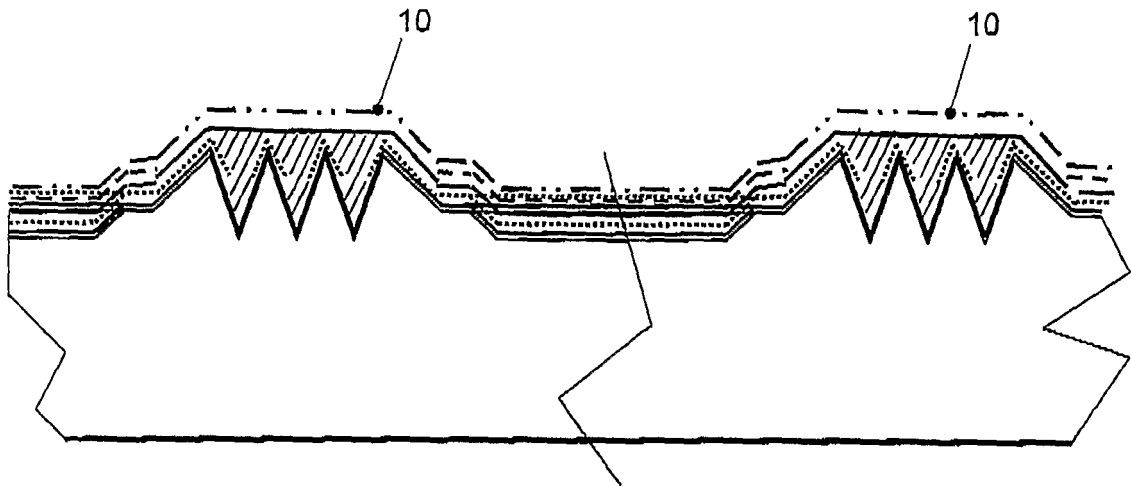

Fig. 13

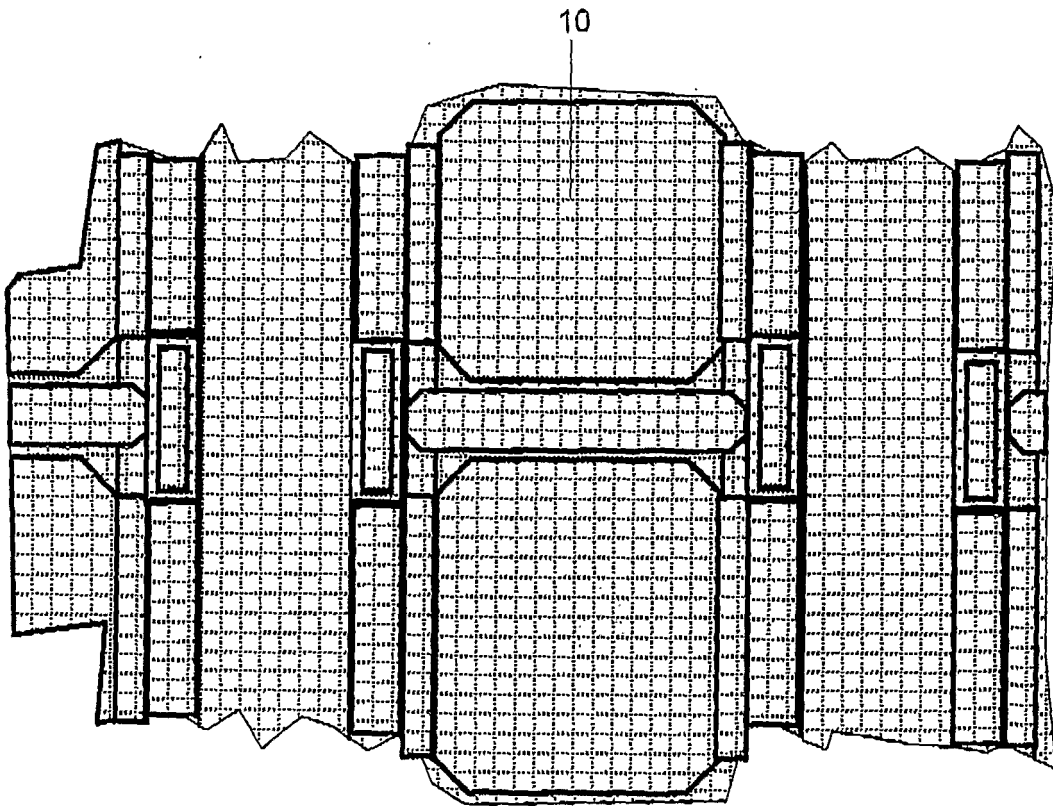

Fig. 14

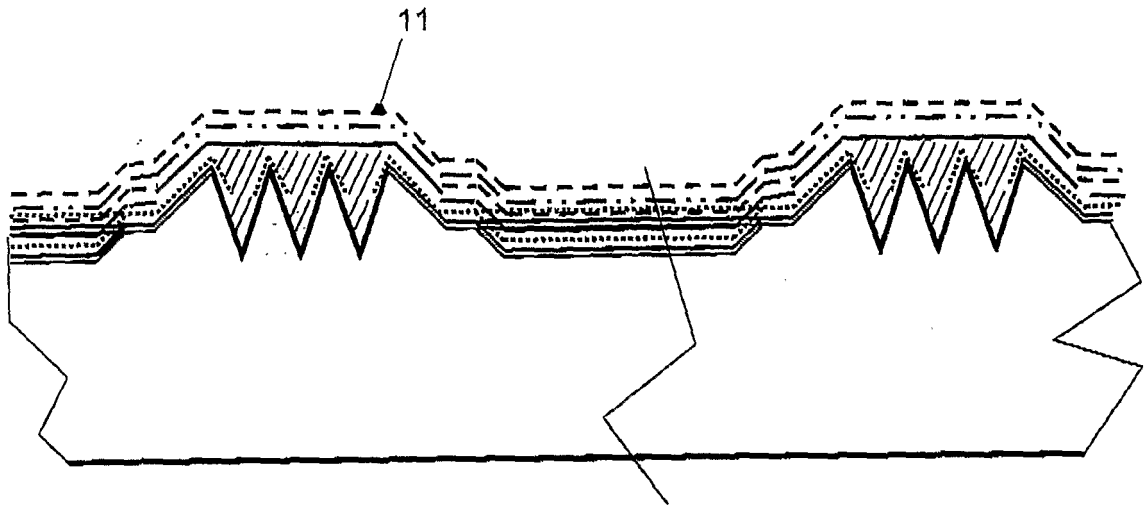

Fig. 15

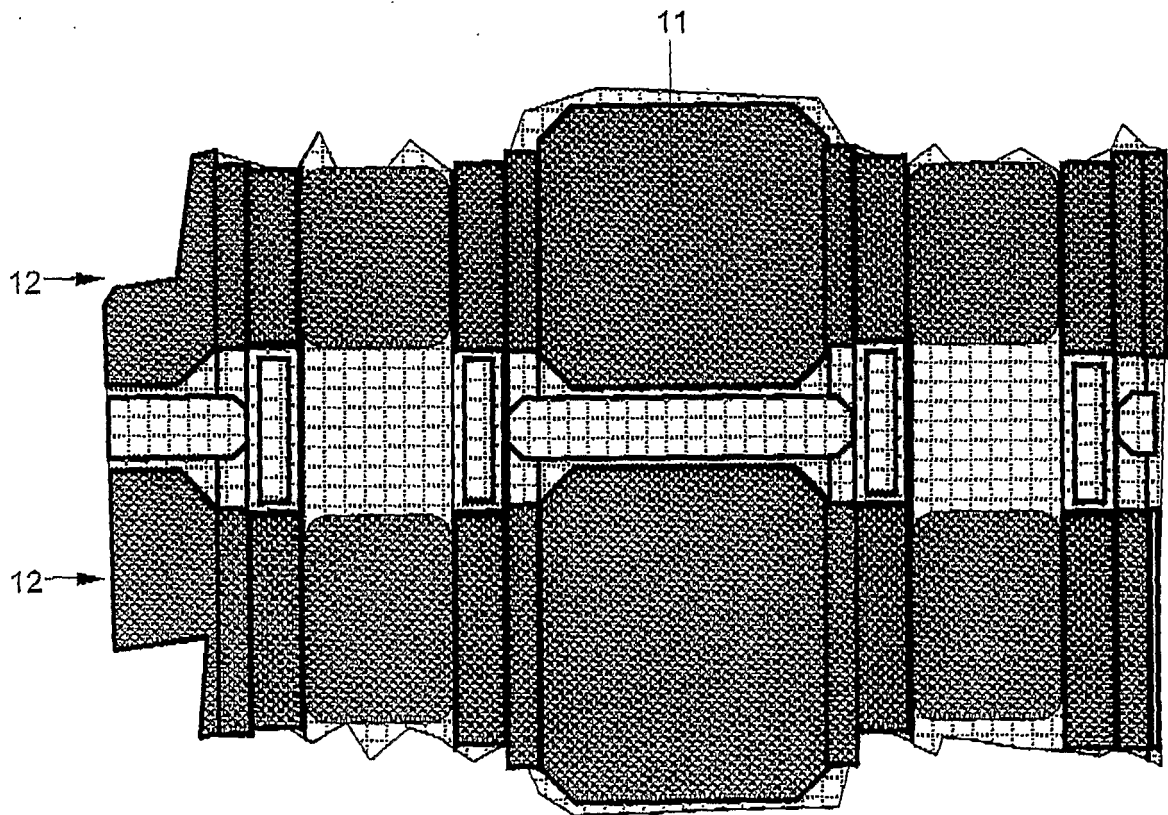

Fig. 16

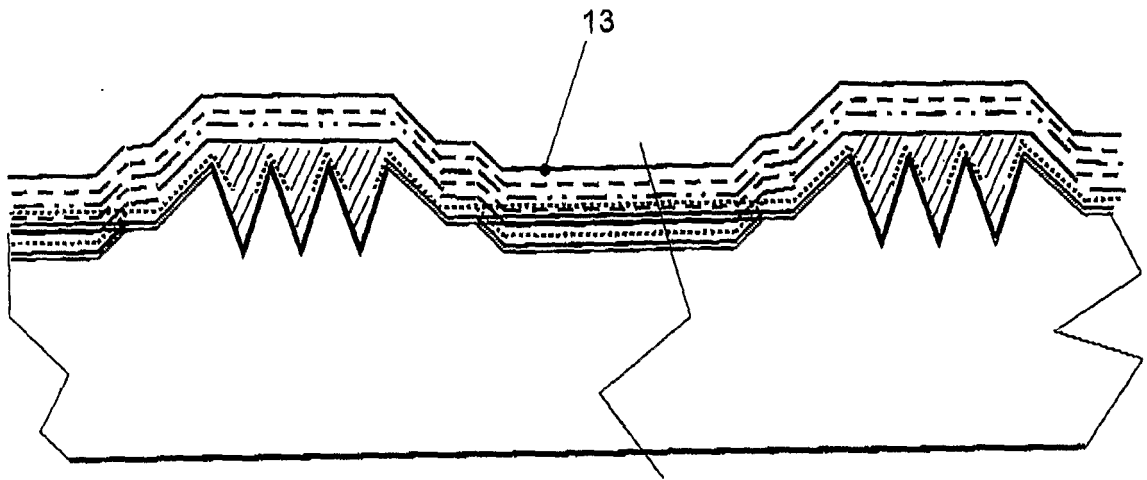

Fig. 17

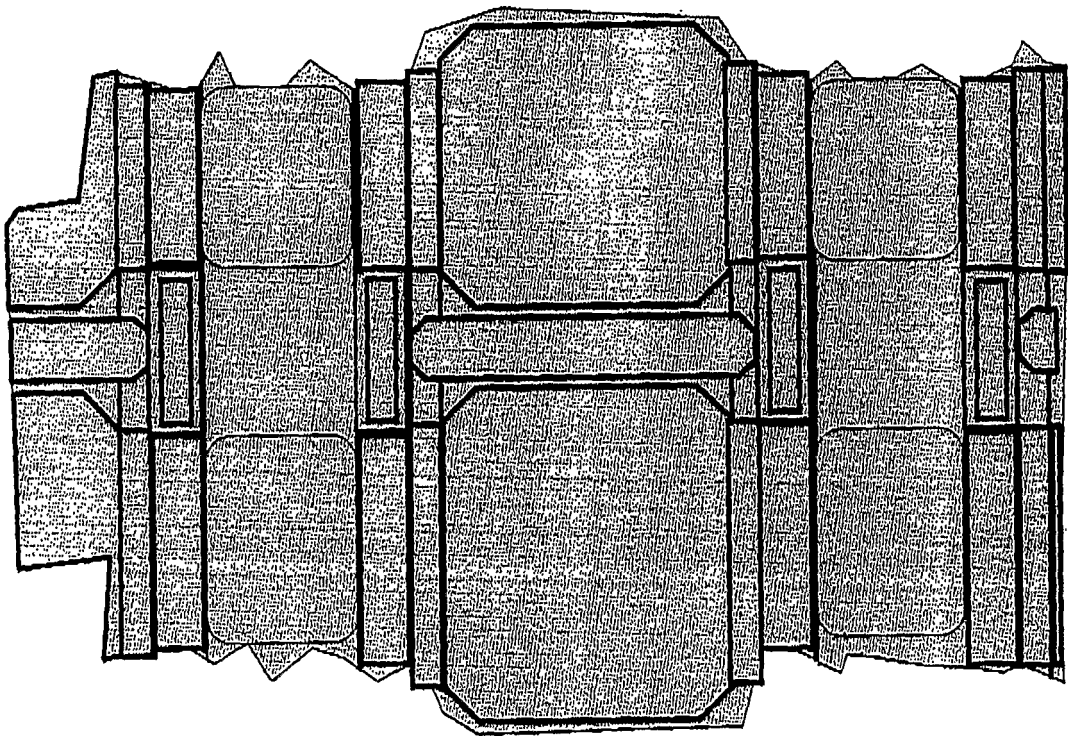

Fig. 18

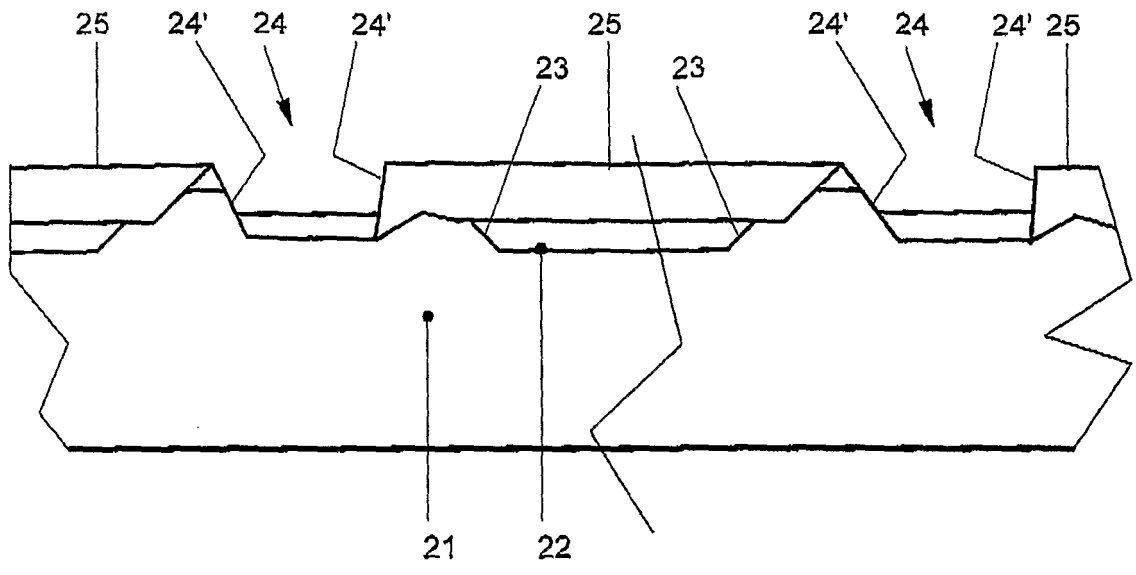

Fig. 19

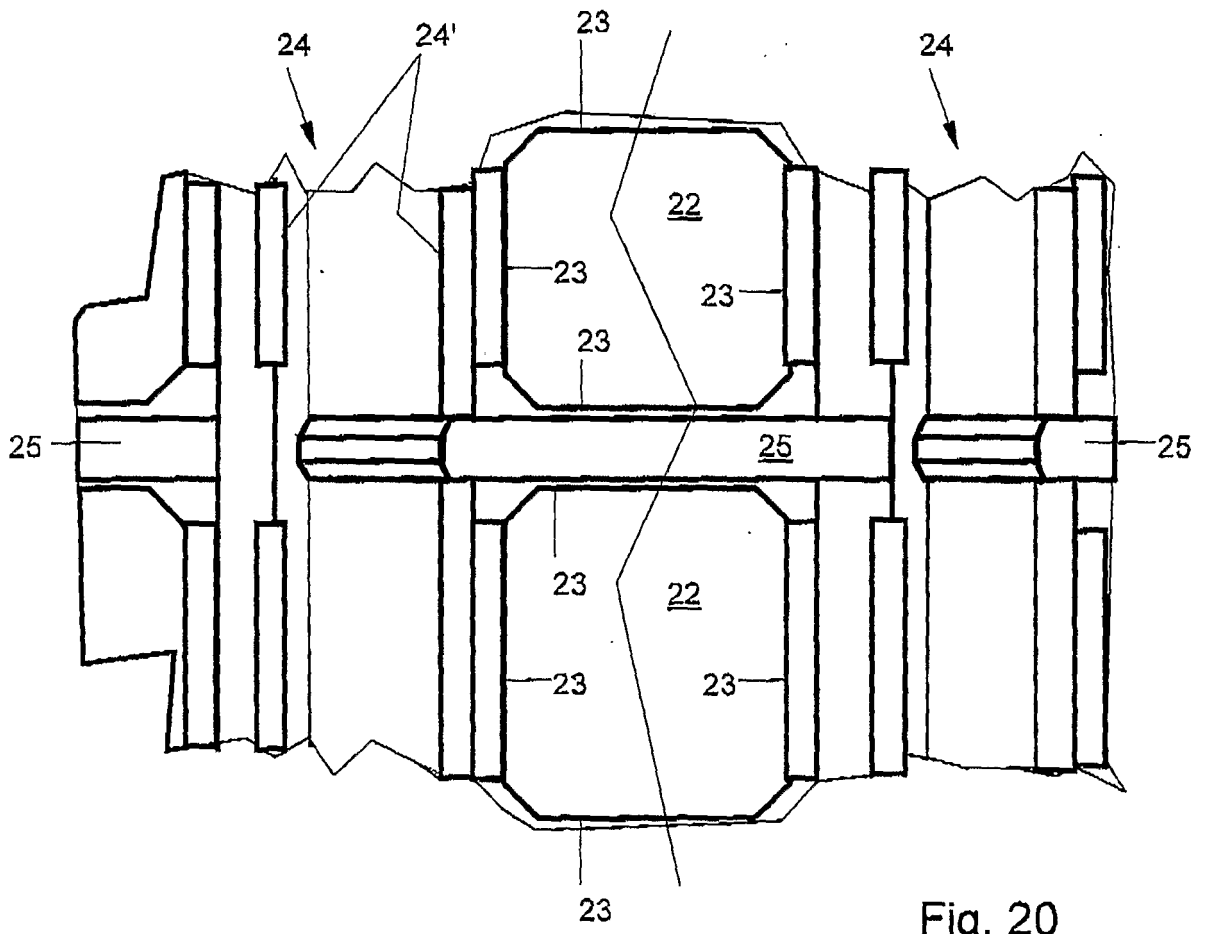

Fig. 20

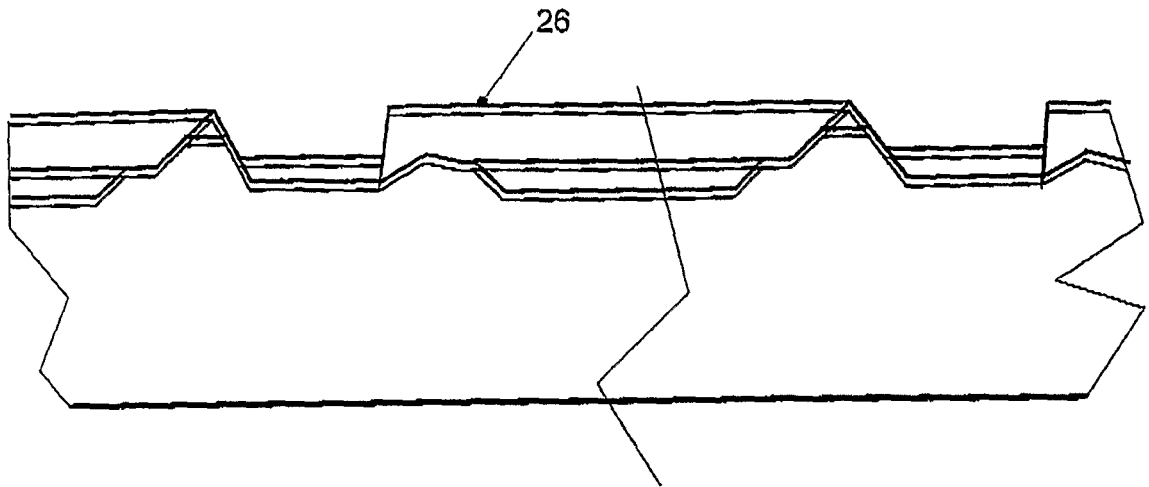

Fig. 21

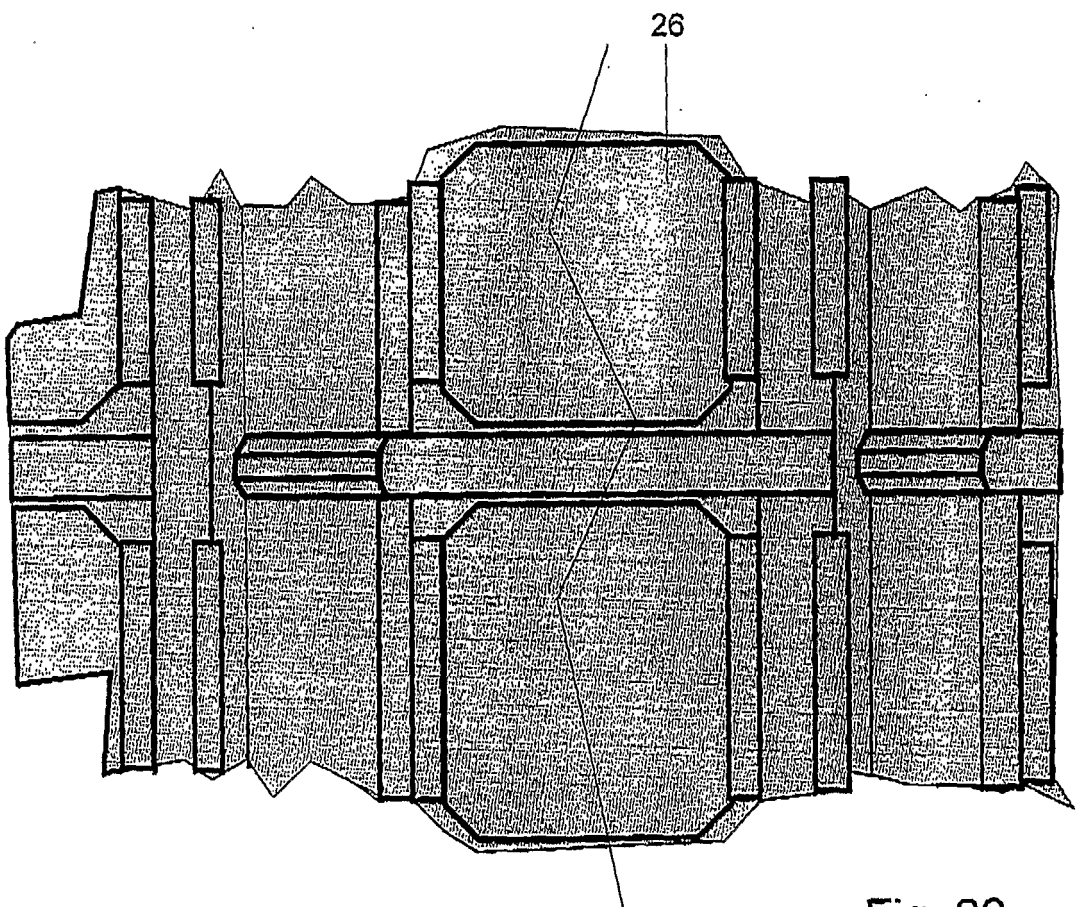

Fig. 22

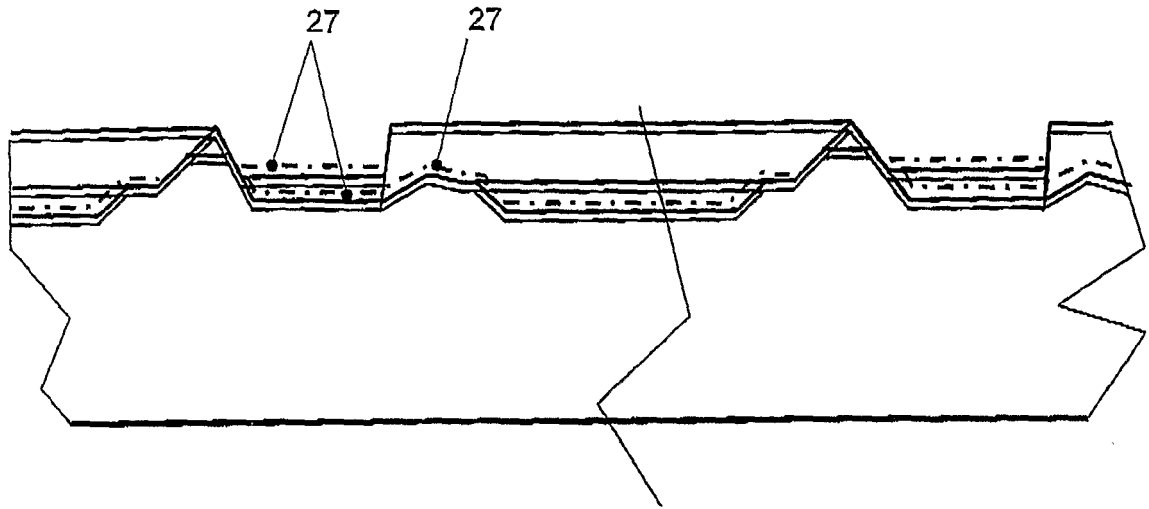

Fig. 23

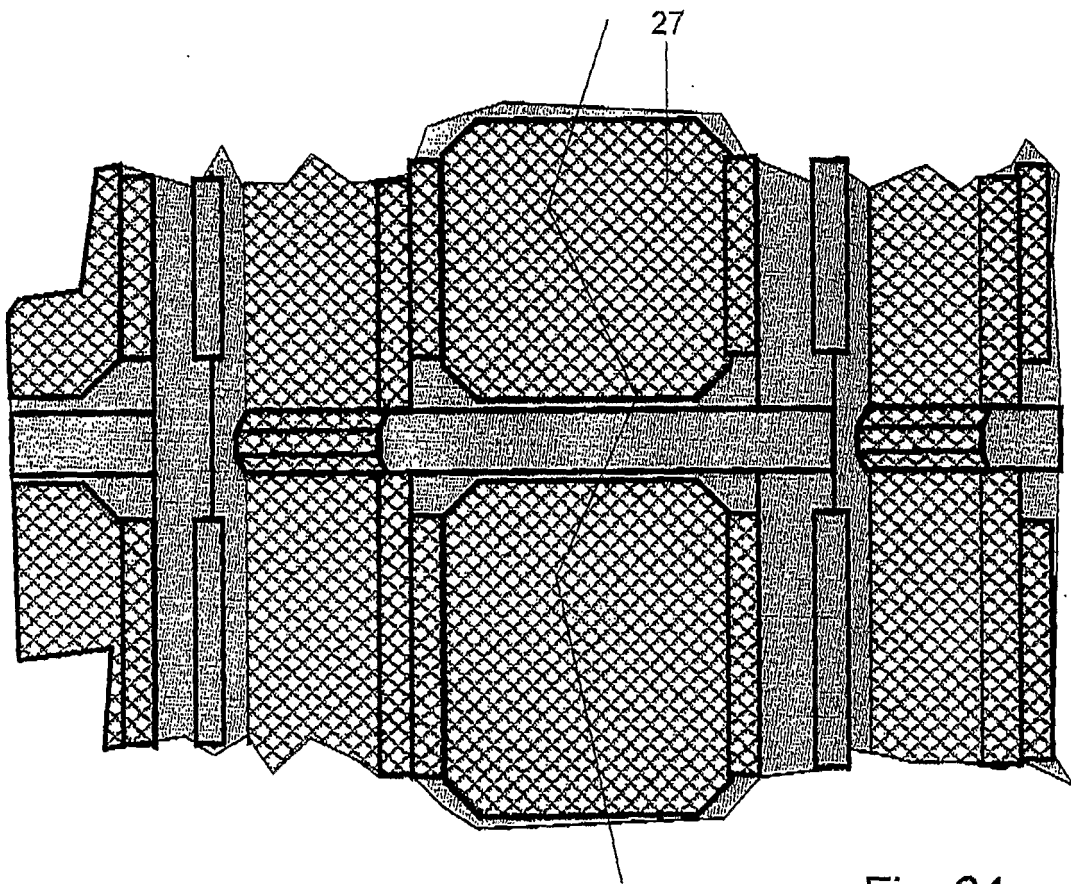

Fig. 24

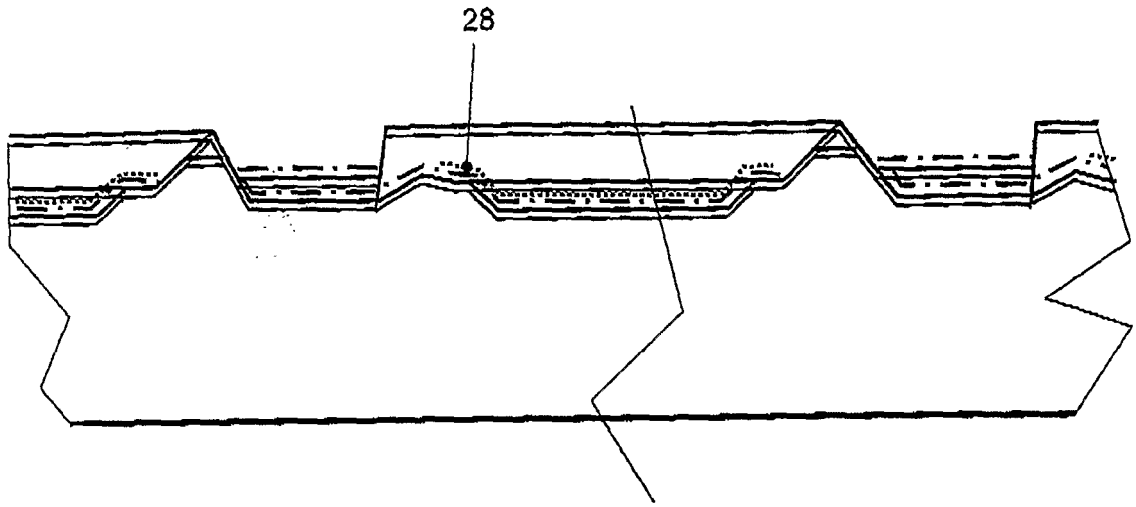

Fig. 25

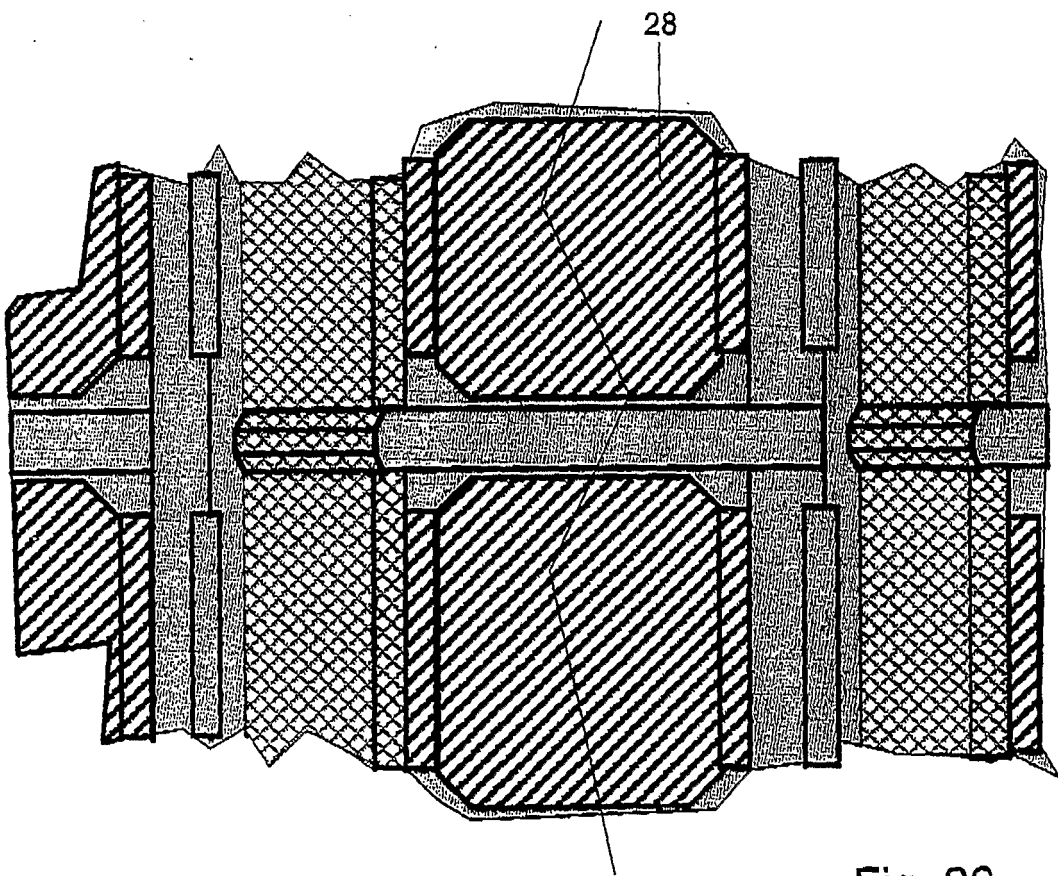

Fig. 26

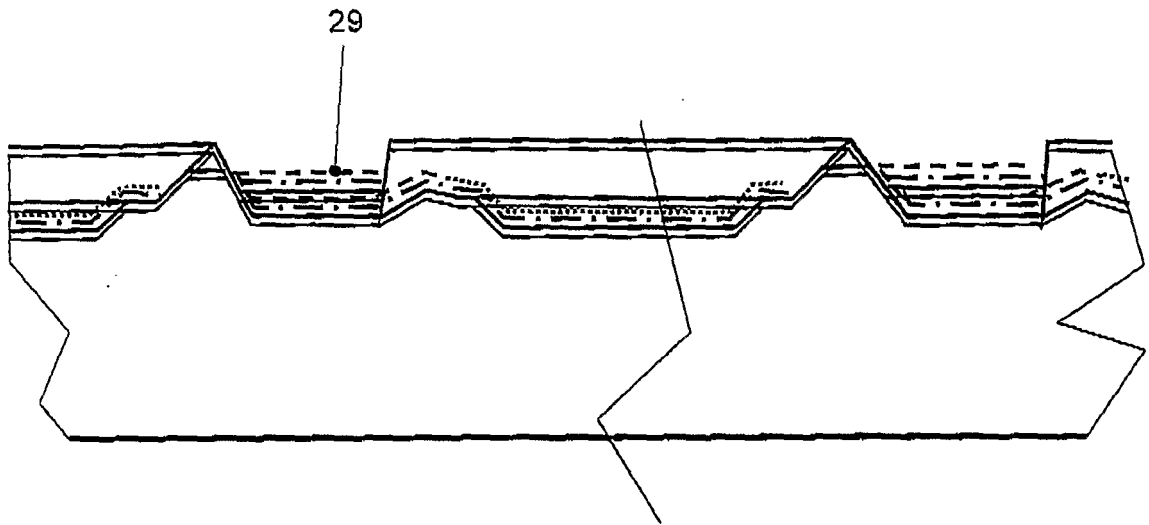

Fig. 27

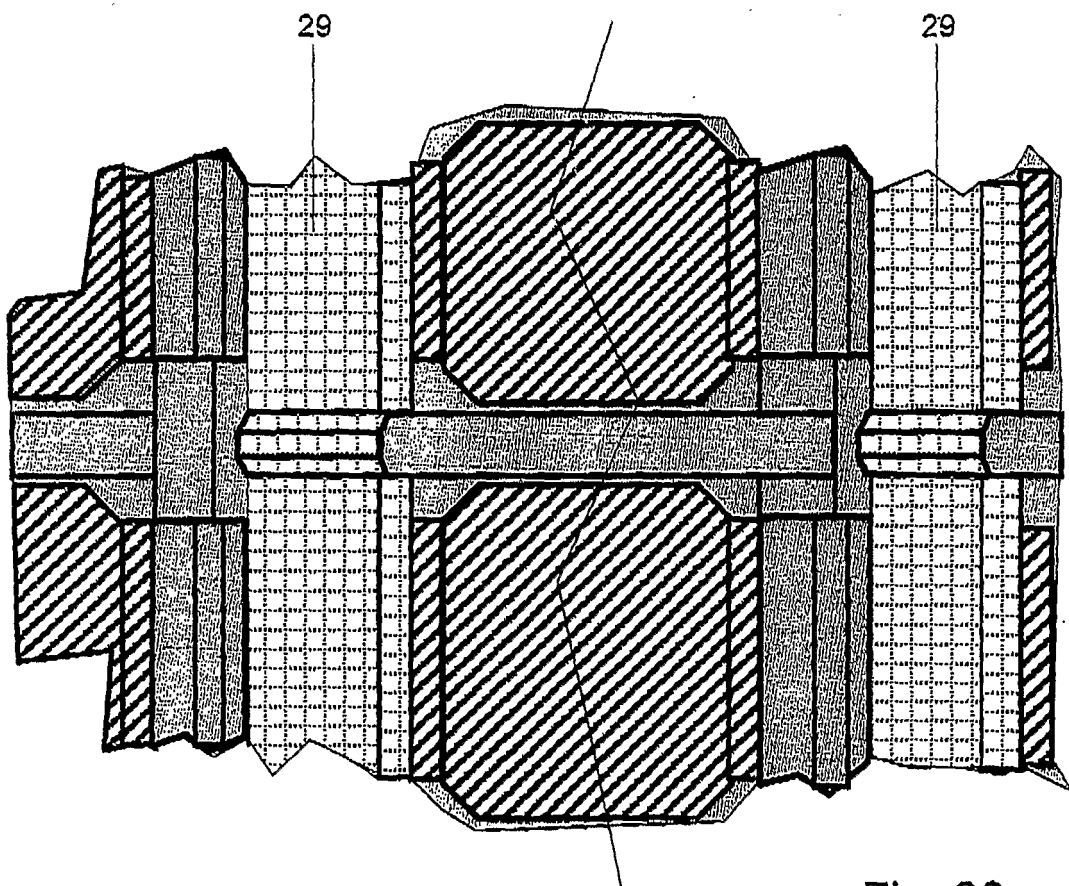

Fig. 28

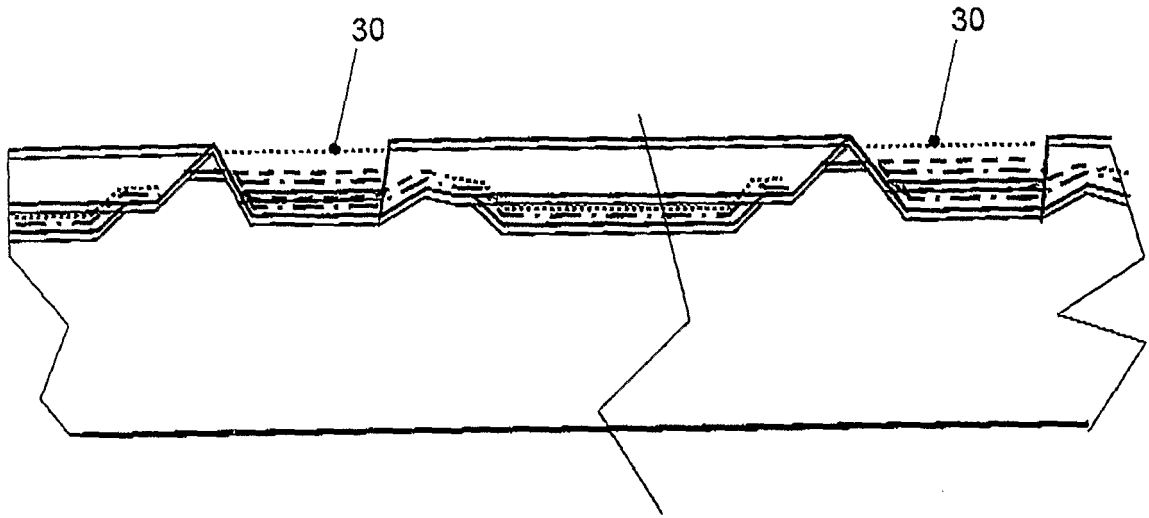

Fig. 29

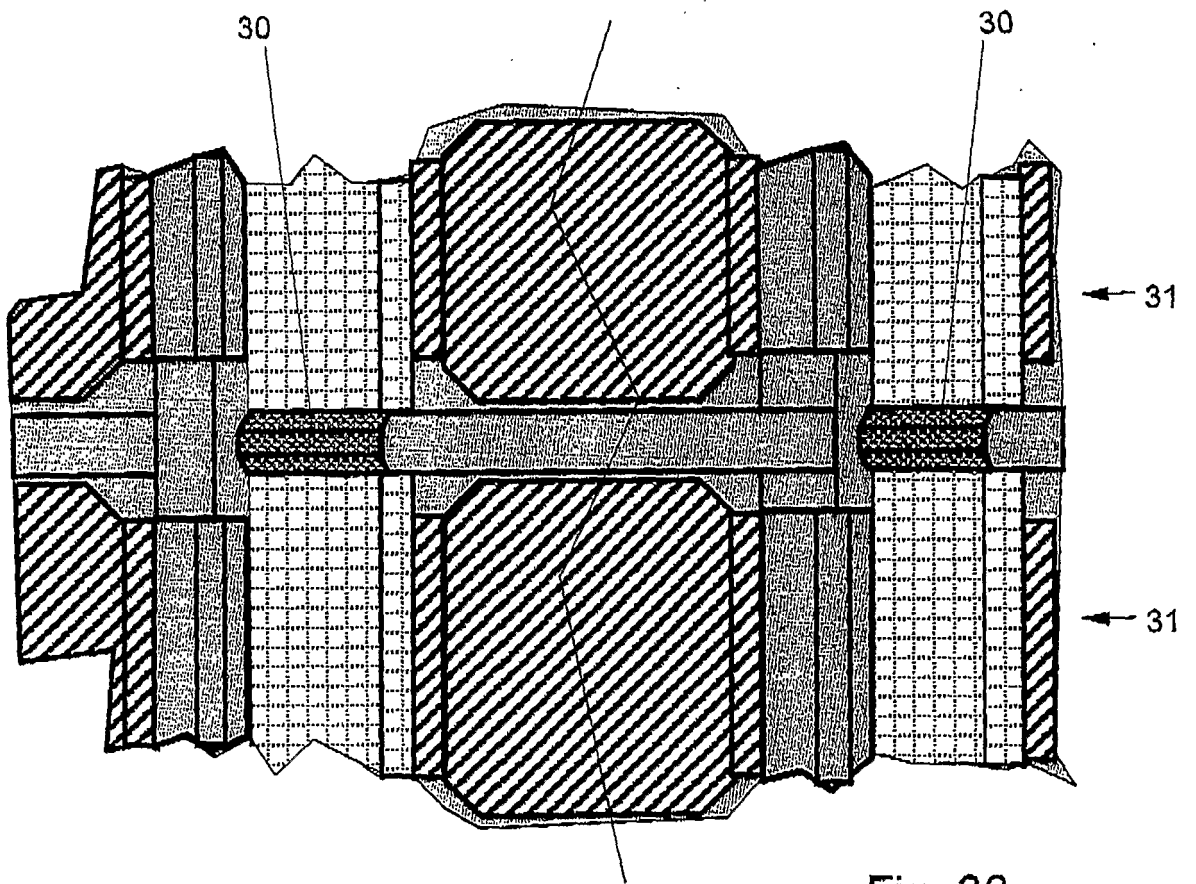

Fig. 30

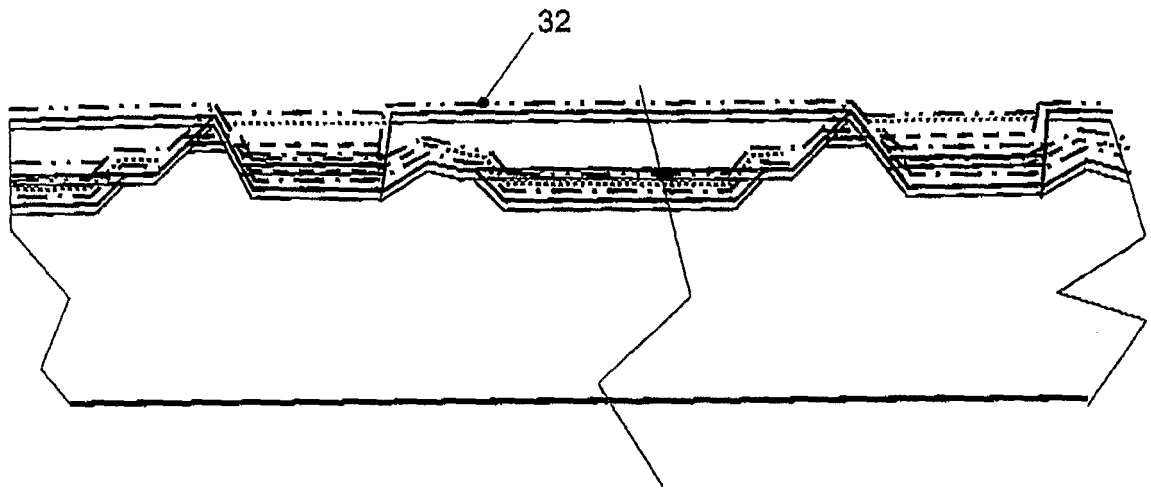

Fig. 31

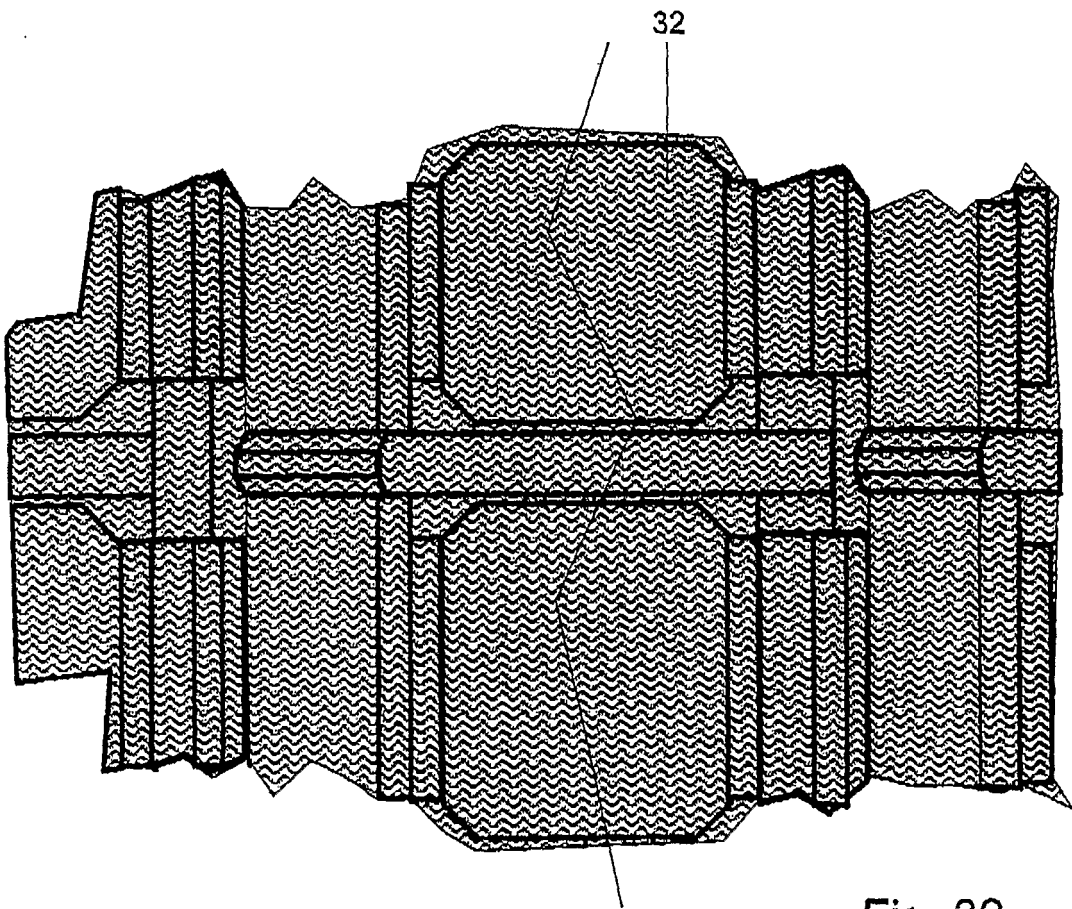

Fig. 32

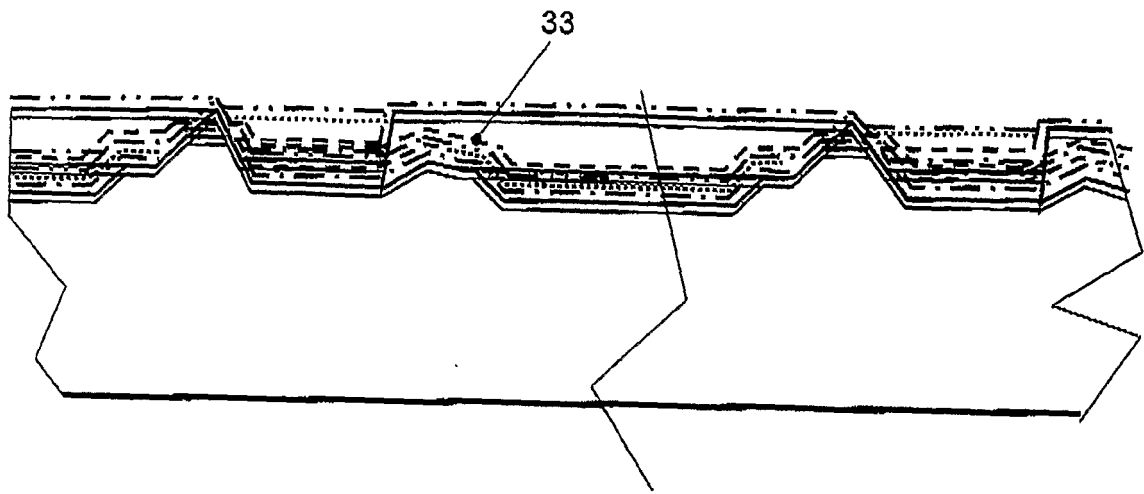

Fig. 33

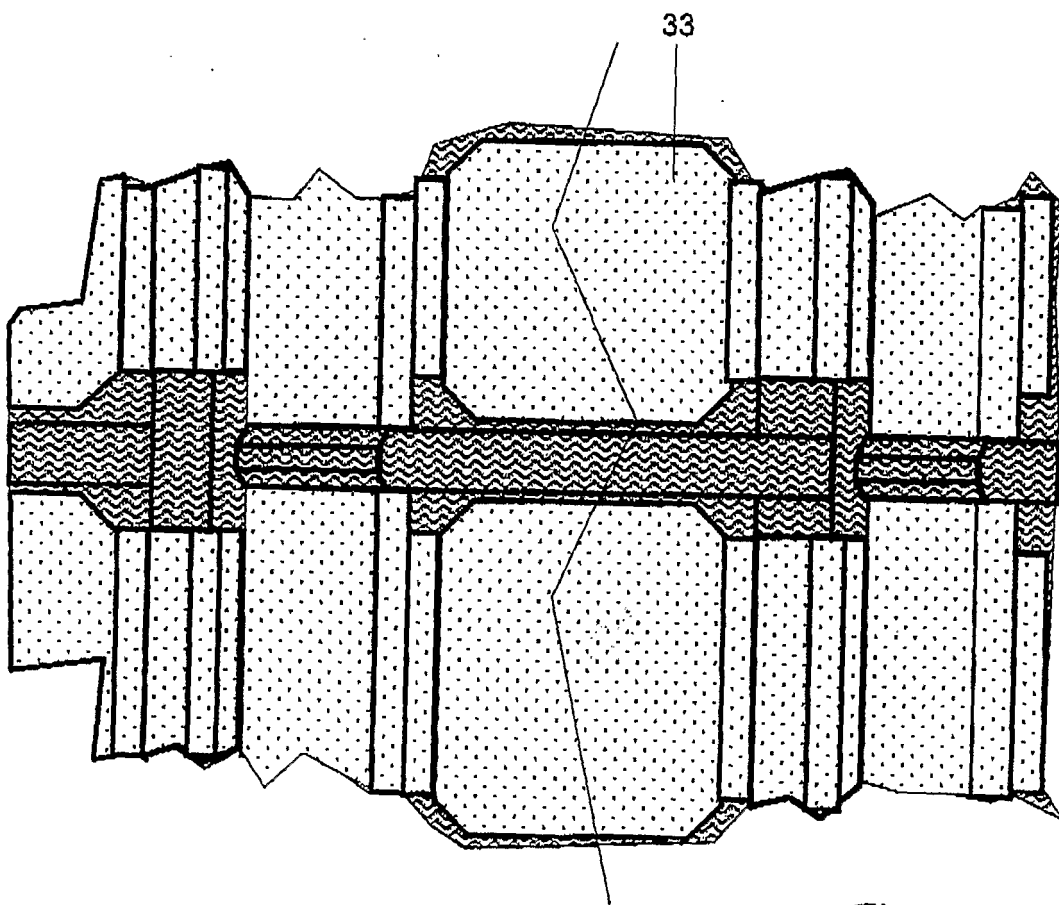

Fig. 34

18/20

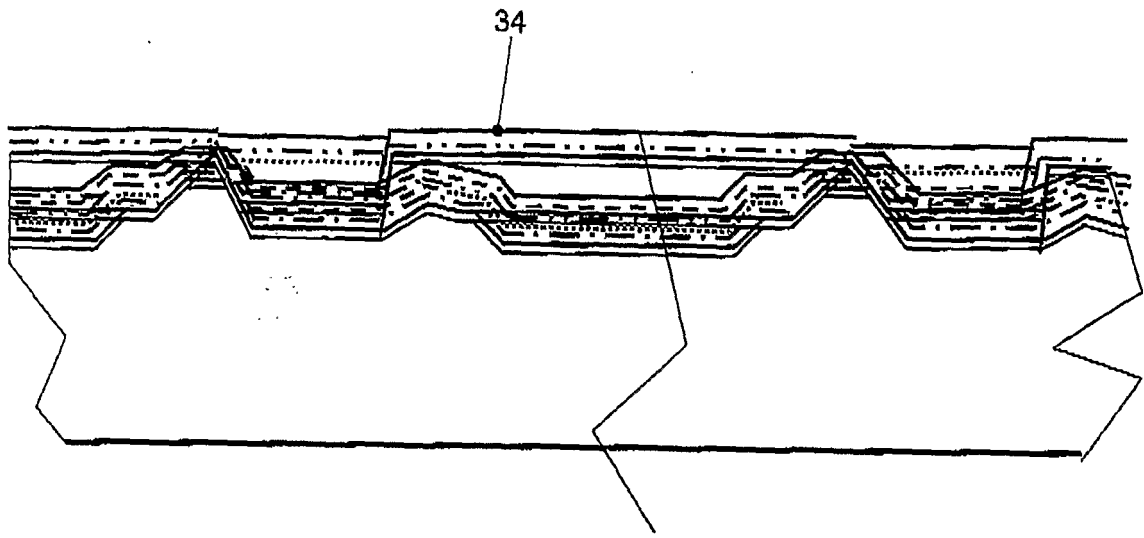

Fig. 35

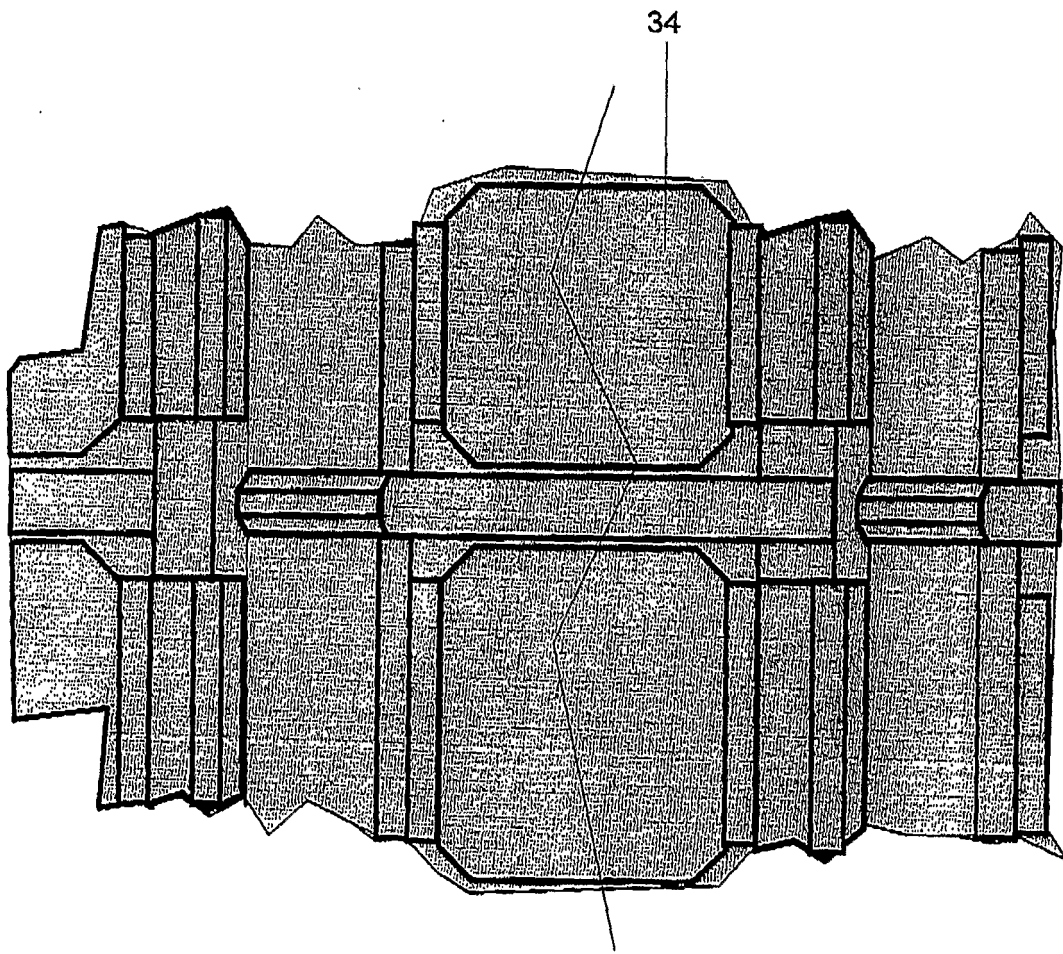
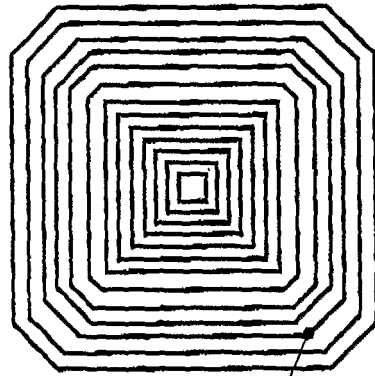

Fig. 36



35

Fig. 37

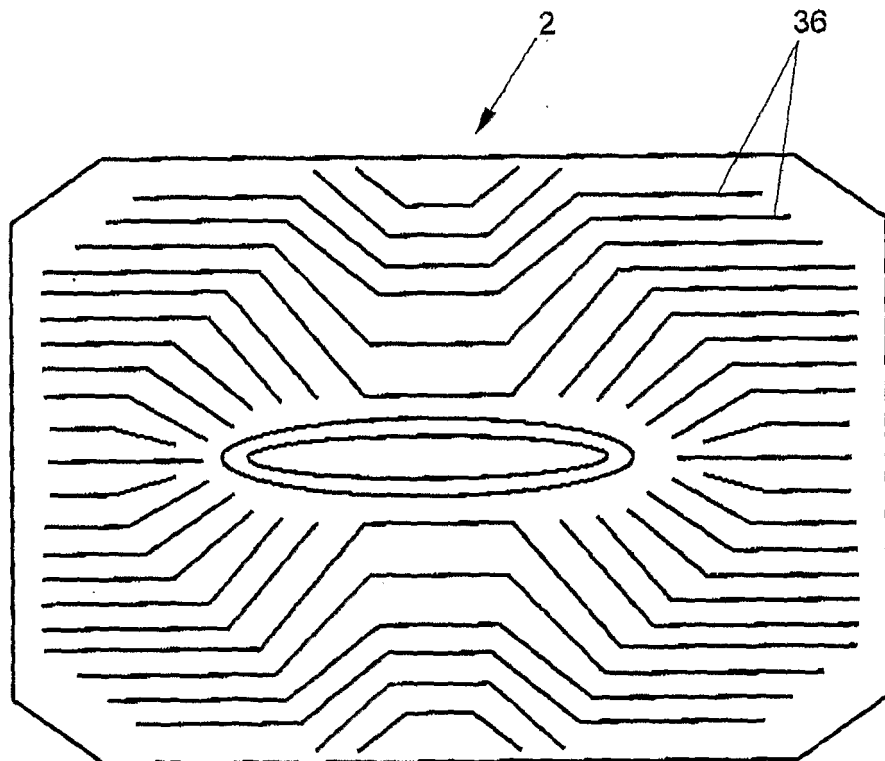

Fig. 38

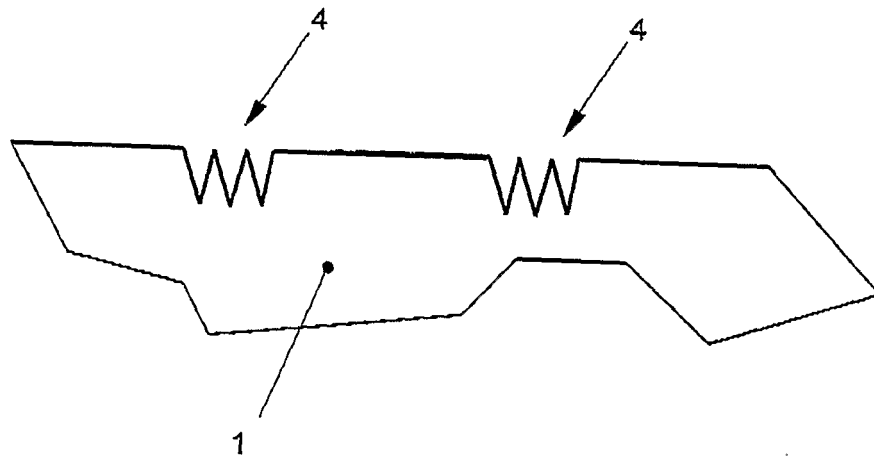

Fig. 39a

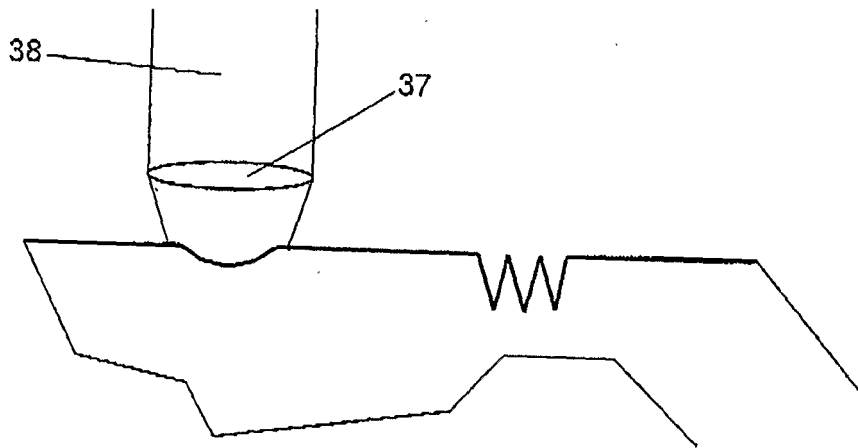

Fig. 39b

# INTERNATIONAL SEARCH REPORT

PCT/NL 03/00937

<b>A. CLASSIFICATION OF SUBJECT MATTER</b> IPC 7 H01L27/00				
According to International Patent Classification (IPC) or to both national classification and IPC				
<b>B. FIELDS SEARCHED</b>				
Minimum documentation searched (classification system followed by classification symbols) IPC 7 H01L H05B				
Documentation searched other than minimum documentation to the extent that such documents are included in the fields searched				
Electronic data base consulted during the international search (name of data base and, where practical, search terms used) EPO-Internal, PAJ, INSPEC, WPI Data				
<b>C. DOCUMENTS CONSIDERED TO BE RELEVANT</b>				
Category °	Citation of document, with indication, where appropriate, of the relevant passages	Relevant to claim No.		
X	US 2002/177007 A1 (SCHWARTZ VLADIMIR ET AL) 28 November 2002 (2002-11-28) abstract paragraph '0024! - paragraph '0025! -----	1, 4, 31, 45		
X	US 2002/055210 A1 (PENG KUANG-CHUNG) 9 May 2002 (2002-05-09) abstract -----	1, 31, 32, 45		
A	XIA Y ET AL: "SOFT LITHOGRAPHY" ANGEWANDTE CHEMIE. INTERNATIONAL EDITION, VERLAG CHEMIE. WEINHEIM, DE, vol. 37, 1998, pages 551-575, XP000985399 ISSN: 0570-0833 the whole document ----- -/--	1-4		
<table style="width: 100%; border: none;"> <tr> <td style="width: 50%; border: none;"><input checked="" type="checkbox"/> Further documents are listed in the continuation of box C.</td> <td style="width: 50%; border: none;"><input checked="" type="checkbox"/> Patent family members are listed in annex.</td> </tr> </table>			<input checked="" type="checkbox"/> Further documents are listed in the continuation of box C.	<input checked="" type="checkbox"/> Patent family members are listed in annex.
<input checked="" type="checkbox"/> Further documents are listed in the continuation of box C.	<input checked="" type="checkbox"/> Patent family members are listed in annex.			
° Special categories of cited documents :				
<table style="width: 100%; border: none;"> <tr> <td style="width: 50%; border: none;">                     *A* document defining the general state of the art which is not considered to be of particular relevance                      *E* earlier document but published on or after the international filing date                      *L* document which may throw doubts on priority claim(s) or which is cited to establish the publication date of another citation or other special reason (as specified)                      *O* document referring to an oral disclosure, use, exhibition or other means                      *P* document published prior to the international filing date but later than the priority date claimed                 </td> <td style="width: 50%; border: none;">                     *T* later document published after the international filing date or priority date and not in conflict with the application but cited to understand the principle or theory underlying the invention                      *X* document of particular relevance; the claimed invention cannot be considered novel or cannot be considered to involve an inventive step when the document is taken alone                      *Y* document of particular relevance; the claimed invention cannot be considered to involve an inventive step when the document is combined with one or more other such documents, such combination being obvious to a person skilled in the art.                      *&amp;* document member of the same patent family                 </td> </tr> </table>			*A* document defining the general state of the art which is not considered to be of particular relevance *E* earlier document but published on or after the international filing date *L* document which may throw doubts on priority claim(s) or which is cited to establish the publication date of another citation or other special reason (as specified) *O* document referring to an oral disclosure, use, exhibition or other means *P* document published prior to the international filing date but later than the priority date claimed	*T* later document published after the international filing date or priority date and not in conflict with the application but cited to understand the principle or theory underlying the invention *X* document of particular relevance; the claimed invention cannot be considered novel or cannot be considered to involve an inventive step when the document is taken alone *Y* document of particular relevance; the claimed invention cannot be considered to involve an inventive step when the document is combined with one or more other such documents, such combination being obvious to a person skilled in the art. *&* document member of the same patent family
*A* document defining the general state of the art which is not considered to be of particular relevance *E* earlier document but published on or after the international filing date *L* document which may throw doubts on priority claim(s) or which is cited to establish the publication date of another citation or other special reason (as specified) *O* document referring to an oral disclosure, use, exhibition or other means *P* document published prior to the international filing date but later than the priority date claimed	*T* later document published after the international filing date or priority date and not in conflict with the application but cited to understand the principle or theory underlying the invention *X* document of particular relevance; the claimed invention cannot be considered novel or cannot be considered to involve an inventive step when the document is taken alone *Y* document of particular relevance; the claimed invention cannot be considered to involve an inventive step when the document is combined with one or more other such documents, such combination being obvious to a person skilled in the art. *&* document member of the same patent family			
Date of the actual completion of the international search <p style="text-align: center; font-size: 1.2em;">26 April 2004</p>		Date of mailing of the international search report <p style="text-align: center; font-size: 1.2em;">06/05/2004</p>		
Name and mailing address of the ISA European Patent Office, P.B. 5818 Patentlaan 2 NL - 2280 HV Rijswijk Tel. (+31-70) 340-2040, Tx. 31 651 epo nl, Fax: (+31-70) 340-3016		Authorized officer <p style="text-align: center; font-size: 1.2em;">De Laere, A</p>		

## INTERNATIONAL SEARCH REPORT

PCT/NL 03/00937

C.(Continuation) DOCUMENTS CONSIDERED TO BE RELEVANT		
Category °	Citation of document, with indication, where appropriate, of the relevant passages	Relevant to claim No.
A	WO 99/54786 A (JACKMAN REBECCA J ; MASSACHUSETTS INST TECHNOLOGY (US); WHITESIDES GEO) 28 October 1999 (1999-10-28) the whole document	1
P,X	WO 03/065474 A (DIJKSMAN JOHAN F ; DUINEVELD PAULUS C (NL); KONINKL PHILIPS ELECTRONIC) 7 August 2003 (2003-08-07) the whole document	1-4, 31, 32, 35, 36, 45
P,X	US 2002/195928 A1 (DRAIN KIERAN F ET AL) 26 December 2002 (2002-12-26) abstract	1, 4, 31, 32, 45

# INTERNATIONAL SEARCH REPORT

Information on patent family members

PCT/NL 03/00937

Patent document cited in search report	Publication date	Patent family member(s)	Publication date
US 2002177007 A1	28-11-2002	WO 02097862 A2	05-12-2002
US 2002055210 A1	09-05-2002	TW 474115 B JP 2002151258 A US 2003030061 A1	21-01-2002 24-05-2002 13-02-2003
WO 9954786 A	28-10-1999	CA 2329412 A1 EP 1080394 A1 JP 2002512124 T WO 9954786 A1	28-10-1999 07-03-2001 23-04-2002 28-10-1999
WO 03065474 A	07-08-2003	WO 03065474 A1	07-08-2003
US 2002195928 A1	26-12-2002	WO 03001490 A2 US 2002196386 A1 US 2002196401 A1	03-01-2003 26-12-2002 26-12-2002

专利名称(译)	用于制造有机电致发光显示装置的方法，用于这种方法的基板和利用该方法获得的有机电致发光显示装置		
公开(公告)号	<a href="#">EP1581970A1</a>	公开(公告)日	2005-10-05
申请号	EP2003789653	申请日	2003-12-24
[标]申请(专利权)人(译)	欧提比集团有限公司		
申请(专利权)人(译)	OTB集团B.V.		
当前申请(专利权)人(译)	OTB集团B.V.		
[标]发明人	BRU R PETER EVERS MARINUS FRANCISCUS JOHANUS		
发明人	BRU R, PETER EVERS, MARINUS, FRANCISCUS, JOHANUS		
IPC分类号	H01L51/52 H01L27/00 H01L27/32 H01L51/00 H01L51/56		
CPC分类号	F21V5/045 H01L27/3283 H01L51/0004 H01L51/52 H01L51/5253 H01L51/56 F21V21/00 H01L51/5275		
优先权	1022269 2002-12-24 NL		
外部链接	<a href="#">Espacenet</a>		

#### 摘要(译)

一种用于制造有机电致发光显示装置的方法，其中层的布置被施加到基板，使得在第一方向上，第一导体以及在第二方向上延伸，而在导体的交叉点之间是有机电致发光连接。本发明提供了一种在电张力的作用下发光的基板，该基板由塑料制成并具有表面结构，该表面结构形成至少许多待施加的层的边界。本发明还提供了一种用于制造有机电致发光显示装置的根据本发明的方法的基板，其中基板由塑料制成并且具有表面结构，该表面结构形成至少一些边界。要应用的图层。本发明还提供了一种用该方法获得的有机电致发光显示装置。