

(19)



(11)

EP 2 983 225 B1

(12)

EUROPEAN PATENT SPECIFICATION

(45) Date of publication and mention of the grant of the patent:
01.04.2020 Bulletin 2020/14

(51) Int Cl.:
H01L 51/52 ^(2006.01) **H01L 27/32** ^(2006.01)
G09G 3/32 ^(2016.01)

(21) Application number: **15168681.3**

(22) Date of filing: **21.05.2015**

(54) FLEXIBLE DISPLAY DEVICE AND METHOD OF FABRICATING THE SAME

FLEXIBLE ANZEIGEVORRICHTUNG UND VERFAHREN ZUR HERSTELLUNG DAVON
DISPOSITIF D’AFFICHAGE FLEXIBLE ET SON PROCÉDÉ DE FABRICATION

(84) Designated Contracting States:
AL AT BE BG CH CY CZ DE DK EE ES FI FR GB GR HR HU IE IS IT LI LT LU LV MC MK MT NL NO PL PT RO RS SE SI SK SM TR

(30) Priority: **04.08.2014 KR 20140099996**

(43) Date of publication of application:
10.02.2016 Bulletin 2016/06

(73) Proprietor: **LG Display Co., Ltd.**
Seoul 150-721 (KR)

(72) Inventor: **Kim, TaeWoo**
Paju-si, Gyeonggi-do (KR)

(74) Representative: **Viering, Jentschura & Partner mbB**
Patent- und Rechtsanwälte
Am Brauhaus 8
01099 Dresden (DE)

(56) References cited:
EP-A1- 1 830 336 US-A1- 2012 020 056
US-A1- 2012 288 685 US-A1- 2013 076 268

EP 2 983 225 B1

Note: Within nine months of the publication of the mention of the grant of the European patent in the European Patent Bulletin, any person may give notice to the European Patent Office of opposition to that patent, in accordance with the Implementing Regulations. Notice of opposition shall not be deemed to have been filed until the opposition fee has been paid. (Art. 99(1) European Patent Convention).

Description

BACKGROUND OF THE INVENTION

1. Field of the Invention

[0001] The present invention relates to a flexible display device, and more particularly, to a flexible display device which can achieve reliability against repeated bending and minimize damage to a display panel by reducing whitening, and a method of fabricating the same.

2. Description of the Conventional Art

[0002] Flat panel display devices have reduced weight and volume compared to cathode ray tube display devices. Typical flat panel display devices include liquid crystal displays, field emission displays, plasma display panels, organic light-emitting diode displays (OLED displays), and the like.

[0003] Among them, the OLED display is a self-emissive display in which an organic light-emitting diode provided on a display panel has high luminance and low operating voltage characteristics and emits light by itself. Hence, the OLED display has a high contrast ratio and can be made super-thin. Also, the OLED display can easily implement moving images due to its short response time of several microseconds (μ s), has an unlimited viewing angle, and is stable at a low temperature.

[0004] Numerous efforts for implementing a flexible display device have been made in recent years to fulfill a variety of purposes such as the ease of carrying it around, versatility in configuration, damage prevention, etc. For instance, a screen-bendable flexible display device can be implemented by making a liquid crystal display or an organic light-emitting diode display of a flexible substrate.

[0005] FIG. 1A is a view schematically showing a structure of a related art flexible display device, and FIG. 1B is a pattern diagram of the force applied to the display device when the flexible display device of FIG. 1A is bent. Referring to FIGS. 1A and 1B, the related art flexible display device includes a plastic substrate 2, a driving element layer 3 formed on the substrate 2, a protective film layer 7 including a protective film for protection of the underlying layer, and a polarizing film layer 8.

[0006] The plastic substrate 2 is a base substrate where a variety of display elements and electrode patterns for implementing a display device are formed. The driving element layer 3 includes signal lines, transistors, e.g. thin film transistors, etc., and a display element layer made up of organic light-emitting diodes formed over or under the driving element layer 3.

[0007] Further, the protective film layer 7 serves to prevent damage to the driving element layer 3 caused by moisture penetration from the outside or impact, and the polarizing film layer 8 serves to compensate optical characteristics of the display device. The flexible display de-

vice of this structure bends to some degree when bent in the Y-axis direction. As it bends, a tensile force is applied outward and a compressive force is applied inward. Accordingly, the protective film layer 7 and the polarizing film layer 8 undergo changes in physical properties. Thus, whitening occurs in which white spots are seen on the surfaces, and the driving element layer 3 will suffer from such problems as damage to the thin film transistors, disconnection of the signal lines, and so on.

[0008] In EP 1830336 A1 it is shown to form an anti-deformation structure on the surface of a flexible plate-shaped part. The anti-deformation structure includes protrusions and depressions that are shaped such that adjacent protrusions come into contact with each other when the plate shaped part is bent and therewith restricting further deformation.

[0009] In US 2012/0288685 A1 a thin-film element assembly is shown, which includes a flexible flat base part on which in a center region a plurality of thin film elements are disposed. On an outer region of the flexible flat base part convex portions are disposed on the flexible flat base part.

[0010] In US 2013/0076268 A1 an organic light-emitting display apparatus is shown, which includes a flexible substrate having a light-emitting diode disposed on a center region of the flexible substrate. An encapsulation member is encapsulating the light-emitting diode and an outer region of the flexible substrate is folded with respect to the center region.

SUMMARY OF THE INVENTION

[0011] In various embodiments, a flexible display device is provided. The flexible display device includes the features according to claim 1.

[0012] In a configuration of various embodiments, the center region may be arranged within an active area of the flexible display device.

[0013] In a configuration of various embodiments, the flexible display device may further include a light transmissive layer disposed over the display element layer and configured to adjust a neutral plane of the flexible display device to lie at the driving element layer and the display element layer when the flexible display device is bent.

[0014] In a configuration of various embodiments, the light transmissive layer has an inorganic film coated on the surface.

[0015] In a configuration of various embodiments, the inorganic film includes silicon dioxide SiO_2 or an inorganic compound containing silicon dioxide SiO_2 .

[0016] In a configuration of various embodiments, the back plate film includes polyethylene terephthalate (PET) or transparent polycarbonate (PC).

[0017] In a configuration of various embodiments, the back plate film supports outer regions of the flexible display device while the cut out portion formed in the center region of the back plate film allows the center region of

the flexible display device to bend upward and downward by an external force.

[0018] In various embodiments, a method of fabricating a flexible display device is provided. The method includes the features of claim 6.

[0019] In a configuration of various embodiments, the method may further include forming a light transmissive layer over the display element layer to adjust a neutral plane of the flexible display device to lie at the driving element layer and the display element layer when the flexible display device is bent.

[0020] In a configuration of various embodiments, the forming the light transmissive layer may include preparing a coating solution of polyimide dissolved in a solvent with a boiling point of 100°C or less, and applying the coating solution over the entire surface of the substrate by a slit coating method. The method may further include placing the substrate coated with the polyimide solution into a pre-heated chamber, pumping air into the heated chamber to harden the coating solution at a pressure not greater than a given pressure, and removing the substrate from the heated chamber.

[0021] In a configuration of various embodiments, the coating solution may be applied at a thickness from 20 μ m to 50 μ m.

[0022] In a configuration of various embodiments the method may further include pre-heating the chamber to a temperature between 60°C and 80°C.

[0023] Accordingly, one aspect of the present invention is to provide a flexible display device which eliminates whitening occurring on a protective film layer and a polarizing film layer upon bending, and minimizes damage to a driving element layer and a display element layer, and a method of fabricating the same.

[0024] Further scope of applicability of the present invention will become apparent from the detailed description given hereinafter.

BRIEF DESCRIPTION OF THE DRAWINGS

[0025] The accompanying drawings, which are included to provide a further understanding of the invention and are incorporated in and constitute a part of this specification, illustrate embodiments and together with the description serve to explain the principles of the invention.

[0026] In the drawings:

FIG. 1A is a view schematically showing a structure of a related art flexible display device;

FIG. 1B is a pattern diagram of the force applied to the display device when the flexible display device of FIG. 1A is bent;

FIG. 2 is a view showing a structure of a flexible display device according to an embodiment of the present invention;

FIG. 3 is a view illustrating a shape the display panel of FIG. 2;

FIG. 4 is a view showing in detail a cross-section

structure of part of the display panel of the flexible display device according to the embodiment of the present invention;

FIGS. 5A to 5G are views showing a method of fabricating a flexible display device according to an embodiment of the present invention; and

FIG. 6 is a graph showing the modulus of elasticity versus temperature of polyimide (PI) used in this process.

DETAILED DESCRIPTION OF THE INVENTION

[0027] Advantages and features of the present invention and a method of accomplishing them can be understood more readily by reference to the following detailed description of embodiments and the accompanying drawings. The present invention may, however, be embodied in many different forms and should not be construed as being limited to the embodiments set forth herein. Rather, these embodiments are provided so that this invention will be thorough and complete and will fully convey the concept of the invention to those skilled in the art, and the present invention will only be defined by the appended claims.

[0028] Throughout the specification, like reference numerals indicate like parts. When terms "include," "have," "consist of," etc. are used, the relevant subject may include other parts unless the term "only" is used to define the contents thereof. As used herein, the singular forms "a," "an" and "the" are intended to include the plural forms as well, unless otherwise stated.

[0029] When the position relation between two parts is described using terms like "on", "above", "below", "next to" etc., one or more parts may be positioned between the two parts as long as the term 'immediately' or 'directly' is not used. When temporal relations are described using terms like "after", "subsequent to", "next", "before", etc., these terms do not limit temporal positions.

[0030] Although the terms first, second, third, etc. may be used herein to describe various elements, these elements should not be limited by these terms. These terms are used to distinguish one element from another. Thus, a first element discussed below could be termed a second element without departing from the scope of the present invention. Respective features of various embodiments of the present invention can be joined or combined with each other partly or wholly, various ways of interworking or driving can be technologically achieved, and the respective embodiments can be executed independently from each other or in conjunction with each other.

[0031] Hereinafter, a flexible display device and a method of fabricating the same according to a preferred embodiment of the present invention will be described with reference to the drawings. In particular, FIG. 2 is a view showing a structure of a flexible display device according to an embodiment of the present invention.

[0032] Referring to FIG. 2, the flexible display device includes a display panel 100 where an active area A/A

displaying an image on a flexible substrate 110 and a non-active area N/A externally surrounding the active area externally surrounding the active area A/A are defined, and a driving IC D-IC mounted on one side of the display panel 100.

[0033] A plurality of gate lines GL and data lines DL are formed to cross each other in the active area A/A of the display panel 100, and a plurality of pixels PX each including at least one thin film transistor and an organic light-emitting diode are formed at the crossing points. In addition, a variety of signal lines are formed to be vertical or horizontal to the lines GL and DL. The signal lines and the thin film transistors constitute a driving element layer on the substrate, and the organic light-emitting diodes constitute a display element layer.

[0034] A gate driving circuit having a GIP (gate in panel) structure that is electrically connected to the pixels PX and supplies a gate signal may be mounted in the non-active area N/A of the display panel 100. The driving IC D-IC that supplies a variety of signals for driving, including a data signal, is mounted in the non-active area A/A on one side edge of the display panel 100. The substrate 110 of the display panel 100 may be made of a plastic material which is flexible so as to make the display device maintain its display performance even when bent like a piece of paper.

[0035] A light transmissive layer 140 is formed over the entire surface of the substrate 110, and prevents damage to the driving element layer and display element layer formed on the substrate 110 when the display panel 100 is bent. The light transmissive layer 140 emits light from the display element layer substantially without loss, and also adjusts the position of a neutral plane of the display panel 100 to correspond to the driving element layer and the display element layer, in order to minimize the tensile or compressive force applied to the driving element layer and the display element layer as the display panel 100 is bent. Accordingly, the material and thickness of the light transmissive layer 140 are determined so the neutral plane of the display panel 100 lies at the driving element layer and the display element layer, corresponding to the substrate 110. That is, the light transmissive layer 140 is formed so it has the same Young's modulus as the substrate 100.

[0036] The neutral plane is defined as a plane where the compressive force and tensile force generated in a bent portion formed by bending the display panel 100 are the smallest. The compressive force and tensile force are the largest on both surfaces of the display panel 100, gradually get smaller toward the inside, and are the smallest at the center. In an example, when two substrates having the same physical properties are attached together, the neutral plane is formed at the point of attachment of the two substrates; and two substrates having different physical properties are attached together, the neutral plane is located away from the center depending on their physical properties

[0037] If the light transmissive layer 140 is omitted from

the display panel 100 of FIG. 2, for example, either the compressive or tensile force caused by bending is maximally applied to the driving element layer and display element layer located on the surface of the substrate 110, thus causing damage. Accordingly, the light transmissive layer 140 is provided on the entire surface of the substrate 110 including the driving element layer and the display element layer in a way that corresponds to the physical properties of the substrate 110, so that the neutral plane is formed at the driving element layer and the display element layer to make the compressive and tensile forces caused by bending as small as possible. Therefore, according to the embodiment of the present invention, damage to the driving element layer and the display element layer can be avoided.

[0038] As the light transmissive layer 140 is located on the outermost part of the display panel 100, a thin hard-coating film is formed on the light transmissive layer 140 so as to offer resistance to scratches from outside forces. A plate film 170 is attached on the back side of the substrate 110 to maintain the overall rigidity of the display panel 100. The plate film 170 has a cut portion 175 formed by cutting the center region of the display panel 100 in one direction.

[0039] The cut portion 175 is formed by removing a portion at which bending occurs, in order to overcome difficulties in application of the plate film 170 which occur as the plate film 170 is bent into an unintended shape due to its flexibility and in order to make the display panel 100 bend well in an intended shape. Accordingly, the plate film 170 keeps the outer region of the display panel 100 from hanging down, and at the same time allows the center region of the display panel 100 to easily bend upward and downward by external force.

[0040] FIG. 3 is a view illustrating a shape of the display panel 100 of FIG. 2. In particular, FIG. 3 illustrates an example in which, as the cut portion 175 of the plate film 170 is formed in the center region of the display panel 100, both sides of the display panel 100 are bent forward with respect to the cut portion 175 into a U-shape. A display element layer 130 is also formed on the substrate 110.

[0041] The force acting on the display panel 100 due to bending is concentrated in the center region, a compressive force acts inward from the bend, a tensile force acts outward from the bend, and a neutral plane is formed at a boundary between the regions of compression and tension where the two forces are in equilibrium. Accordingly, the compressive force becomes maximum on the light transmissive layer 140 located on the upper outermost part of the display panel 100, and the tension becomes maximum on the substrate 110.

[0042] The light transmissive layer 140 may have a thickness of $20\mu\text{m}$ to $50\mu\text{m}$, taking the neutral plane into consideration. The light transmissive layer 140 has a hard-coating layer formed on the surface so as to minimize whitening by changes in the physical properties caused by the compressive force or tensile force. The

hard-coating layer is made of an inorganic film, for example, silicon dioxide SiO₂.

[0043] FIG. 4 is a view showing in detail a cross-section structure of part of the display panel of the flexible display device according to the embodiment of the present invention. Referring to FIG. 4, the display panel of the flexible display device includes a substrate 110, a driving element layer 120 and a display element layer 130 formed on the substrate 110, a light transmissive layer 140 formed on the display element layer 130 and defining the driving element layer 120 and the display element layer 130 as a neutral plane, and a back plate film 170 attached to the back side of the substrate 110 and having a cut portion in the center region.

[0044] The light transmissive layer 140 is hard-coated with an inorganic film; that is, it has a hard-coating layer 150 formed on the surface. More specifically, the substrate 110 may be made of polyimide PI, and a back plate film 170 made of polyethylene terephthalate (PET) or transparent polycarbonate (PC) is attached to the back side.

[0045] A plurality of gate lines and data lines and a driving element layer 120 including thin film transistors 121 connected to the gate lines and the data lines, an interlayer insulating film 123, and first electrodes 125 connected to the thin film transistors 121 are formed on the substrate 110.

[0046] A display element layer 130 is formed on the driving element layer 120, and includes banks 131 for separating the pixels, organic light-emitting diodes, each using a first electrode 125 as the anode and made up of a second electrode 133 as the cathode and an emissive layer 135 interposed between the first electrode 125 and the second electrodes 133, and a protective layer 137 sealing the organic light-emitting diodes

[0047] The light transmissive layer 140 is formed on the display element layer 130, uses the driving element layer and the display element layer as a neutral plane, prevents damage upon bending, and allows light emitted from the organic light-emitting diodes to pass forward with the surface. The hard-coating layer 150 is formed on the surface of the light transmissive layer 140 to prevent scratching.

[0048] According to this structure, the center region of the flexible display device is easily bent as the back plate film 170 has a cut portion, the light transmissive layer 140 minimizes damage to the driving element layer 120 and display element layer 130 caused by bending, and no whitening occurs.

[0049] Hereinafter, a method of fabricating a flexible display device according to an embodiment of the present invention will be described with reference to the drawings. In particular, FIGS. 5A to 5G are views showing a method of fabricating a flexible display device according to an embodiment of the present invention.

[0050] Referring to FIGS. 5A to 5G, the method of fabricating a flexible display device according to the embodiment of the present invention includes forming a sub-

strate on carrier glass; forming, on the substrate, a driving element layer including a plurality of thin film transistors; forming, on the driving element layer, a display element layer including organic light-emitting diodes electrically connected to the thin film transistors; forming, on the display element layer, a light transmissive layer defining the driving element layer and the display element layer as a neutral plane; attaching a protective film onto the light transmissive layer; removing the carrier glass and attaching a back plate film onto the back side of the substrate; and forming a cut portion by cutting a given region of the back plate film and removing the protective film.

[0051] Referring to FIG. 5A, in the method of fabricating a display panel of the flexible display device according to an embodiment of the present invention, a fabrication process is performed on carrier glass 105 in order to minimize defects caused by the flexibility of the substrate 110 during fabrication. First of all, carrier glass is prepared, and a substrate 110 is formed on the glass by using polyimide.

[0052] Next, referring to FIG. 5B, a driving element layer 120 including a plurality of thin film transistors is formed on the substrate 110. A process of forming the driving element layer will be described in detail. A plurality of TFTs are formed by performing a predetermined thin film transistor (TFT) process on the substrate 110. First, an active layer made of hydrogenated amorphous silicon, polycrystalline silicon, or oxide semiconductor is formed on the substrate 110.

[0053] Subsequently, a gate insulating film made of silicon nitride SiN_x or silicon dioxide SiO₂ is formed on the substrate 110 including the active layer, and then gate electrodes and gate lines are formed on the gate insulating film. Afterwards, an insulating film made of silicon nitride or silicon dioxide is formed on the gate electrodes and the gate lines. Next, data lines, other driving voltage lines, and source and drain electrodes are formed to constitute thin film transistors 121. Afterwards, an interlayer insulating film 123 is formed over the entire surface of the substrate 110.

[0054] After forming the interlayer insulating film 123, first electrodes 125 connected to the drain electrodes of the TFTs 121 are formed. The first electrodes 125 may serve as the anodes of the organic light-emitting diodes and may be reflective. Accordingly, the TFTs 121, the interlayer insulating film 123, and the first electrodes 125 constitute the driving element layer 120.

[0055] Next, referring to FIG. 5C, banks 131 made of an insulating material, for example, benzocyclobutene (BCB), polyimide, or photacryl are formed on the entire surface of the driving element layer 120. The banks 131 overlap the edges of the first electrodes 125 in a manner that surrounds each pixel as viewed from above, and has a grid-like structure having a plurality of openings when seeing the display panel as a whole.

[0056] An emissive layer 135 is formed on the banks 131 and the portions of the first electrodes 125 exposed by the banks 131. The emissive layer 135 may be made

of a material that emits red, green, blue, and white light, which may be a phosphorescent or fluorescent material. Especially, the emissive layer 135 may further include an electron transport layer, a hole transport layer, an electron injection layer, and a hole injection layer, and the arrangement and structure of the emissive layer 135 may be implemented in various forms as intended by the designer.

[0057] Next, a conductive material is deposited on the entire surface of the substrate 100 including the emissive layer 135 to form second electrodes 133. The second electrodes 133 are made of a material with such a thickness as to allow light transmission therethrough, which may be a transparent conductive material such as ITO, IZO, etc.

[0058] Accordingly, the first electrodes 125 and the second electrodes 133 serve as anodes and cathodes, and constitute organic light-emitting diodes that emit light through the emissive layer 135. In addition, if the flexible display device includes a touch function, touch electrodes for sensing touch may be formed, along with the lines and electrodes of the driving element layer or display element layer.

[0059] Subsequently, referring to FIG. 5D, a protective layer 137 is formed as a sealing structure on the substrate 110 with the second electrodes 133 on it. The protective layer 137 may have a multi-layer structure, rather than a single layer film. In an example, the protective film 137 may be formed by sequentially laminating a first protective film, an organic film, and a second protective film.

[0060] The organic film may be made of an organic material such as polymer, and examples of the organic film include olefin polymer, PET, epoxy resin, fluorine resin, and polysiloxane. The first protective film and the second protective film may be made of an inorganic insulating film such as silicon nitride or silicon dioxide. Especially, if the protective layer 137 further includes a polarizing film, the related art polarizing film attached to the outside can be omitted. This reduces manufacturing costs by structure simplification and makes bending easier as the film is omitted.

[0061] Such a structure is called a face seal structure, which effectively prevents moisture penetration from the outside. Other structures than this structure may be applied according to the design intent. In addition, once the display element layer 130 is formed, a driving IC mounting process may be performed on one side of the substrate 110.

[0062] Subsequently, when the display element layer 130 is formed through the above procedure, a light transmissive layer 140 defining the driving element layer 120 and the display element layer 130 as a neutral plane is formed on the display element layer 130. The light transmissive layer 140 must be produced by a low-temperature process of 100°C or less so as to avoid thermal damage to the underlying display element layer 130. Specifically, a method of fabricating a desirable light transmissive layer 140 will be described. First, a coating solution

of polyimide (PI) dissolved in a solvent with a boiling point below 100°C is prepared, and the coating solution is applied over the entire surface of the substrate 110 by a slit coating method.

[0063] Subsequently, the substrate coated with the polyimide solution is put into a pre-heated chamber, air is pumped into the chamber to harden the coating solution at a pressure not greater than a given pressure, and then the substrate 110 is taken out of the chamber, thereby forming the light transmissive layer 140. The temperature in the chamber recommended for this process ranges from 60°C to 80°C, and the pressure in the chamber is about 0.1 Torr. The light transmissive layer 140 may have a thickness of 20 μm to 50 μm, taking the neutral plane into consideration.

[0064] FIG. 6 is a graph showing the modulus of elasticity versus temperature of polyimide (PI) used in this process. According to the low-temperature process, the storage modulus of the polyimide (PI) must be in the range from 3,000 Mpa to 4,000 Mpa.

[0065] The light transmissive layer 140 produced by the above-stated method protects the driving element layer and the display element layer as a neutral plane and is formed at the two element layers, and the above temperature and pressure conditions and the characteristics of the raw material, i.e., polyimide, help to prevent damage to the light transmissive layer 140 due to a compressive force or tensile force. However, even if the light transmissive layer 140 itself is resistant to compression or tension, it is not resistant to scratches from outside forces. In the embodiment of the present invention, as shown in FIG. 5E, the surface of the light transmissive layer 140 is hard-coated in order to increase the rigidity of the light transmissive layer 140 against physical external forces.

[0066] The hard-coating layer 150 formed by surface treatment of the light transmissive layer 140 contributes to minimize whitening caused by external forces. The hard-coating layer is made of an inorganic film, for example, silicon dioxide SiO₂. The display panel fabricated by this process is thin, which makes it difficult to perform the subsequent processes. Accordingly, a removable protective film 160 is attached to the surface-treated light transmissive layer 140, that is, the hard-coating layer 150.

[0067] Next, as shown in FIG. 5F, the carrier glass (105 of FIG. 5E) located on the back side of the substrate 110 is removed. Subsequently, a back plate film for maintaining the flatness of the display panel is attached to the back side of the substrate 110 from which the carrier glass has been removed. The back plate film may be made of a material such as polyethylene terephthalate (PET) or transparent polycarbonate (PC).

[0068] Although the back plate film can maintain the flatness of the display panel, it weakens the flexibility of the display panel. Thus, as shown in FIG. 5G, a back plate film 170 for maintaining flatness is provided on the back side of the substrate 110, with a cut portion formed

by cutting the center region of the display panel which is expected to be bent, and the protective film (160 of FIG. 5F) attached on the light transmissive layer 140 is removed, thereby completing the fabrication process of the display panel.

[0069] The flexible display device fabricated according to the above-described fabrication method minimizes damage to the driving element layer and display element layer of the display panel caused by bending and reduces whitening.

[0070] Although many details have been set forth in the foregoing description, these details do not limit the scope of the present invention but should be construed as of the preferred embodiment. Thus, the scope of the present invention is not determined by the embodiments but by the claims.

Claims

1. A flexible display device comprising:

a substrate (110);
 a driving element layer (120) including a plurality of transistors (121) on the substrate (110);
 a display element layer (130) including organic light-emitting diodes electrically connected to the transistors (121); and
 a back plate film (170) for maintaining flatness attached to a back side of the substrate (110) and having a single cut out portion (175) formed in a center region of the flexible display device, wherein the single cut out portion (175) is extending up to opposite side edges of the substrate (110), and
characterized in that:
 the driving element layer (120) and the display element layer (130) overlap with the backplate film (170) outside the single cut out portion (175).

2. The flexible display device of claim 1, wherein the center region is arranged within an active area of the flexible display device.

3. The flexible display device of any one of claims 1 or 2, further comprising:

a light transmissive layer (140) disposed over the display element layer (130) and configured to adjust a neutral plane of the flexible display device to lie at the driving element layer (120) and the display element layer (130) when the flexible display device is bent;
 wherein preferably the light transmissive layer (140) has an inorganic film coated on the surface;
 wherein further preferably the inorganic film includes silicon dioxide SiO₂ or an inorganic com-

pound containing silicon dioxide SiO₂.

4. The flexible display device of any one of claims 1 to 3, wherein the back plate film (170) includes polyethylene terephthalate (PET) or transparent polycarbonate (PC).

5. The flexible display device of any one of claims 1 to 4, wherein the back plate film (170) supports outer regions of the flexible display device while the cut out portion formed in the center region of the back plate film (170) allows the center region of the flexible display device to bend upward and downward by an external force.

6. A method of fabricating a flexible display device according to claim 1, the method comprising:

forming a substrate (110) on a carrier glass;
 forming, over the substrate (110), a driving element layer (120) including a plurality of transistors (121);
 forming, over the driving element layer (120), a display element layer (130) including organic light-emitting diodes electrically connected to the transistors (121);
 preferably forming a light transmissive layer (140) over the display element layer (130) to adjust a neutral plane of the flexible display device to lie at the driving element layer (120) and the display element layer (130) when the flexible display device is bent;
 disposing a protective film over the driving element layer (120);
 removing the carrier glass and attaching a back plate film (170) onto a back side of the substrate (110); and
 forming a cut out portion by cutting a given region of the back plate film (170) in one direction and removing the protective film in a center region of the flexible display device.

7. The method of claim 6, wherein the forming the light transmissive layer (140) comprises:

preparing a coating solution of polyimide dissolved in a solvent with a boiling point of 100°C or less;
 applying the coating solution over the entire surface of the substrate (110) by a slit coating method;
 placing the substrate (110) coated with the polyimide solution into a pre-heated chamber;
 pumping air into the heated chamber to harden the coating solution at a pressure not greater than a given pressure; and
 removing the substrate (110) from the heated

chamber;
wherein preferably the coating solution is applied at a thickness from 20 μm to 50 μm .

8. The method of any one of claims 6 or 7, further comprising:
pre-heating the chamber to a temperature between 60°C and 80°C.

Patentansprüche

1. Flexible Anzeigevorrichtung, umfassend:

ein Substrat (110);
eine Ansteuerelementschicht (120) mit einer Vielzahl von Transistoren (121) auf dem Substrat (110);
eine Anzeigeelementschicht (130) mit organischen Leuchtdioden, die elektrisch mit den Transistoren (121) verbunden sind; und
einen Rückplattenfilm (170) zum Aufrechterhalten der Ebenheit, angebracht an einer Rückseite des Substrats (110) und aufweisend einen einzelnen ausgeschnittenen Abschnitt (175), der in einem mittleren Bereich der flexiblen Anzeigevorrichtung ausgebildet ist,
wobei sich der einzelne ausgeschnittene Abschnitt (175) bis zu gegenüberliegenden Seitenkanten des Substrats (110) erstreckt, und

dadurch gekennzeichnet dass:

die Ansteuerelementschicht (120) und die Anzeigeelementschicht (130) mit dem Rückplattenfilm (170) außerhalb des einzelnen ausgeschnittenen Abschnitts (175) überlappen.

2. Flexible Anzeigevorrichtung nach Anspruch 1, wobei der mittlere Bereich in einem aktiven Bereich der flexiblen Anzeigevorrichtung angeordnet ist.
3. Flexible Anzeigevorrichtung nach einem der Ansprüche 1 oder 2, ferner umfassend:

eine über der Anzeigeelementschicht (130) angeordnete lichtdurchlässige Schicht (140), die konfiguriert ist, um eine neutrale Ebene der flexiblen Anzeigevorrichtung so einzustellen, dass sie bei der Ansteuerelementschicht (120) und der Anzeigeelementschicht (130) liegt, wenn die flexible Anzeigevorrichtung abgeknickt wird;
wobei vorzugsweise die lichtdurchlässige Schicht (140) einen anorganischen Film aufweist, der auf die Oberfläche aufgetragen ist;
wobei weiter vorzugsweise der anorganische Film Siliziumdioxid SiO_2 oder eine anorganische Verbindung, die Siliziumdioxid SiO_2 enthält, aufweist.

4. Flexible Anzeigevorrichtung nach einem der Ansprüche 1 bis 3, wobei der Rückplattenfilm (170) Polyethylenterephthalat (PET) oder transparentes Polycarbonat (PC) enthält.

5. Flexible Anzeigevorrichtung nach einem der Ansprüche 1 bis 4, wobei der Rückplattenfilm (170) äußere Bereiche der flexiblen Anzeigevorrichtung stützt, während der ausgeschnittene Abschnitt, der im mittleren Bereich des Rückplattenfilms (170) ausgebildet ist, es dem mittleren Bereich der flexiblen Anzeigevorrichtung ermöglicht, sich durch eine externe Kraft nach oben und unten zu biegen.

6. Verfahren zur Herstellung einer flexiblen Anzeigevorrichtung gemäß Anspruch 1, wobei das Verfahren umfasst:

Ausbilden eines Substrats (110) auf einem Trägerglas;
Ausbilden einer Ansteuerelementschicht (120) mit mehreren Transistoren (121) über dem Substrat (110);
Ausbilden einer Anzeigeelementschicht (130) mit organischen Leuchtdioden, die elektrisch mit den Transistoren (121) verbunden sind, auf der Ansteuerelementschicht (120);
vorzugsweise Ausbilden einer lichtdurchlässigen Schicht (140) über der Anzeigeelementschicht (130), um eine neutrale Ebene der flexiblen Anzeigevorrichtung so einzustellen, dass sie bei der Ansteuerelementschicht (120) und der Anzeigeelementschicht (130) liegt, wenn die flexible Anzeigevorrichtung geknickt wird;
Aufbringen eines Schutzfilms über der Ansteuerelementschicht (120);
Entfernen des Trägerglases und Anbringen eines Rückplattenfilms (170) auf einer Rückseite des Substrats (110); und
Ausbilden eines ausgeschnittenen Abschnitts durch Schneiden eines gegebenen Bereichs des Rückplattenfilms (170) in einer Richtung und Entfernen des Schutzfilms in einem mittleren Bereich der flexiblen Anzeigevorrichtung.

7. Verfahren nach Anspruch 6, wobei das Ausbilden der lichtdurchlässigen Schicht (140) umfasst:

Herstellen einer Beschichtungslösung aus Polyimid, gelöst in einem Lösungsmittel mit einem Siedepunkt von 100°C oder weniger;
Auftragen der Beschichtungslösung über die gesamte Oberfläche des Substrats (110) durch ein Schlitzbeschichtungsverfahren;
Platzieren des mit der Polyimid-Lösung beschichteten Substrats (110) in eine vorgewärm-

te Kammer;
 Pumpen von Luft in die erhitzte Kammer, um die Beschichtungslösung bei einem Druck zu härten, der nicht größer als ein gegebener Druck ist; und
 Entfernen des Substrats (110) aus der erhitzten Kammer;
 wobei vorzugsweise die Beschichtungslösung in einer Dicke von 20µm bis 50µm aufgetragen wird.

8. Verfahren nach einem der Ansprüche 6 oder 7, ferner umfassend:
 Vorheizen der Kammer auf eine Temperatur zwischen 60°C und 80°C.

Revendications

1. Dispositif d'affichage flexible comprenant :

un substrat (110) ;
 une couche d'éléments d'excitation (120) incluant une pluralité de transistors (121) sur le substrat (110) ;
 une couche d'éléments d'affichage (130) incluant des diodes électroluminescentes organiques connectées électriquement aux transistors (121) ; et
 un film de plaque arrière (170) pour maintenir la planéité fixé à un côté arrière du substrat (110) et ayant une seule partie découpée (175) formée dans une région centrale du dispositif d'affichage flexible,
 dans lequel la seule partie découpée (175) s'étend jusqu'aux bords latéraux opposés du substrat (110), et
caractérisé en ce que :
 la couche d'éléments d'excitation (120) et la couche d'éléments d'affichage (130) chevauchent le film de plaque arrière (170) à l'extérieur de la seule partie découpée (175).

2. Dispositif d'affichage flexible selon la revendication 1,
 dans lequel la région centrale est agencée à l'intérieur d'une zone active du dispositif d'affichage flexible.

3. Dispositif d'affichage flexible selon l'une quelconque des revendications 1 ou 2, comprenant en outre :

une couche de transmission de lumière (140) disposée au-dessus de la couche d'éléments d'affichage (130) et configurée pour ajuster un plan neutre du dispositif d'affichage flexible pour se trouver au niveau de la couche d'éléments d'excitation (120) et de la couche d'éléments

d'affichage (130) lorsque le dispositif d'affichage flexible est courbé ;
 dans lequel de préférence la couche de transmission de lumière (140) a un film inorganique revêtu sur la surface ;
 dans lequel de préférence en outre le film inorganique inclut du dioxyde de silicium SiO₂ ou un composé inorganique contenant du dioxyde de silicium SiO₂.

4. Dispositif d'affichage flexible selon l'une quelconque des revendications 1 à 3,
 dans lequel le film de plaque arrière (170) inclut du polyéthylène téréphtalate (PET) ou du polycarbonate transparent (PC).

5. Dispositif d'affichage flexible selon l'une quelconque des revendications 1 à 4,
 dans lequel le film de plaque arrière (170) supporte des régions externes du dispositif d'affichage flexible alors que la partie découpée formée dans la région centrale du film de plaque arrière (170) permet à la région centrale du dispositif d'affichage flexible d'être courbée vers le haut et vers le bas par une force externe.

6. Procédé de fabrication d'un dispositif d'affichage flexible selon la revendication 1, le procédé comprenant :

la formation d'un substrat (110) sur un verre de support ;
 la formation, sur le substrat (110), d'une couche d'éléments d'excitation (120) incluant une pluralité de transistors (121) ;
 la formation, sur la couche d'éléments d'excitation (120), d'une couche d'éléments d'affichage (130) incluant des diodes électroluminescentes organiques connectées électriquement aux transistors (121) ;
 la formation, de préférence, d'une couche de transmission de lumière (140) au-dessus de la couche d'éléments d'affichage (130) pour ajuster un plan neutre du dispositif d'affichage flexible pour qu'il se trouve au niveau de la couche d'éléments d'excitation (120) et de la couche d'éléments d'affichage (130) lorsque le dispositif d'affichage flexible est courbé ;
 la mise en place d'un film protecteur au-dessus de la couche d'éléments d'excitation (120) ;
 le retrait du verre de support et la fixation du film de plaque arrière (170) sur un côté arrière du substrat (110) ; et
 la formation d'une partie découpée en découpant une région donnée du film de plaque arrière (170) dans une direction et en retirant le film protecteur dans une région centrale du dispositif d'affichage flexible.

7. Procédé selon la revendication 6, dans lequel la formation de la couche de transmission de lumière (140) comprend :

la préparation d'une solution de revêtement de polyimide dissoute dans un solvant avec un point d'ébullition de 100 °C ou moins ;
 l'application de la solution de revêtement sur l'ensemble de la surface du substrat (110) par un procédé de revêtement par fentes ;
 la mise en place du substrat (110) revêtu avec la solution de polyimide dans une chambre préchauffée ;
 le pompage d'air dans la chambre chauffée pour durcir la solution de revêtement à une pression ne dépassant pas une pression donnée ; et
 le retrait du substrat (110) de la chambre chauffée ;
 dans lequel de préférence, la solution de revêtement est appliquée à une épaisseur de 20 µm à 50 µm.

8. Procédé selon l'une quelconque des revendications 6 ou 7, comprenant en outre :
 le préchauffage de la chambre à une température comprise entre 60 °C et 80 °C.

30

35

40

45

50

55

FIG. 1A

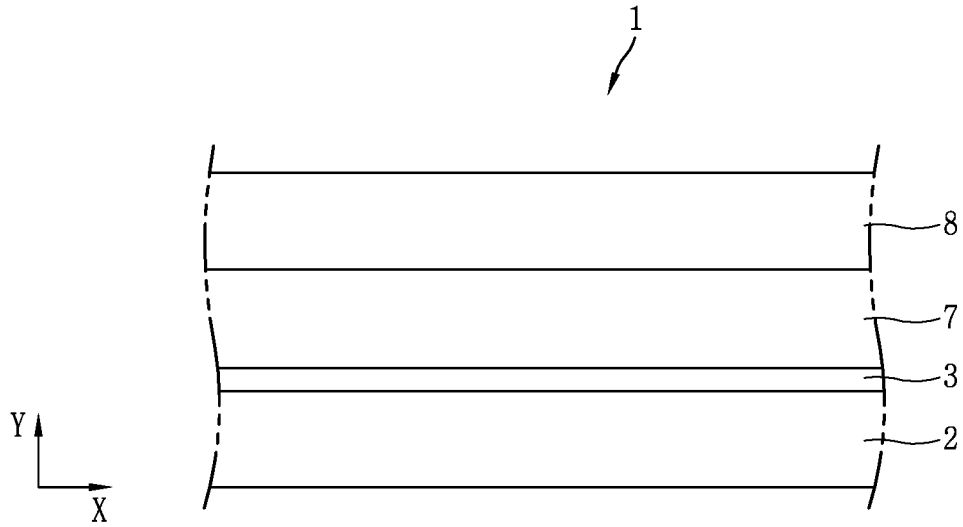

FIG. 1B

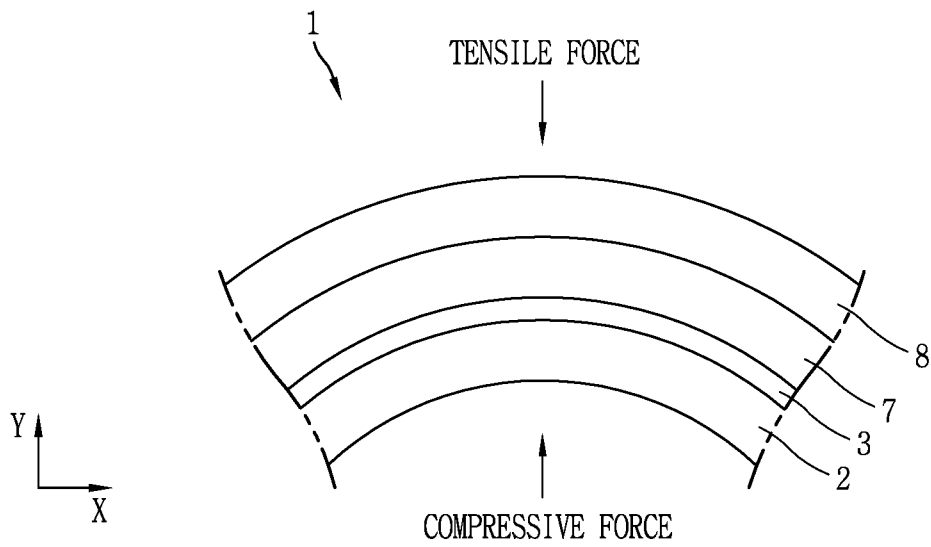

FIG. 2

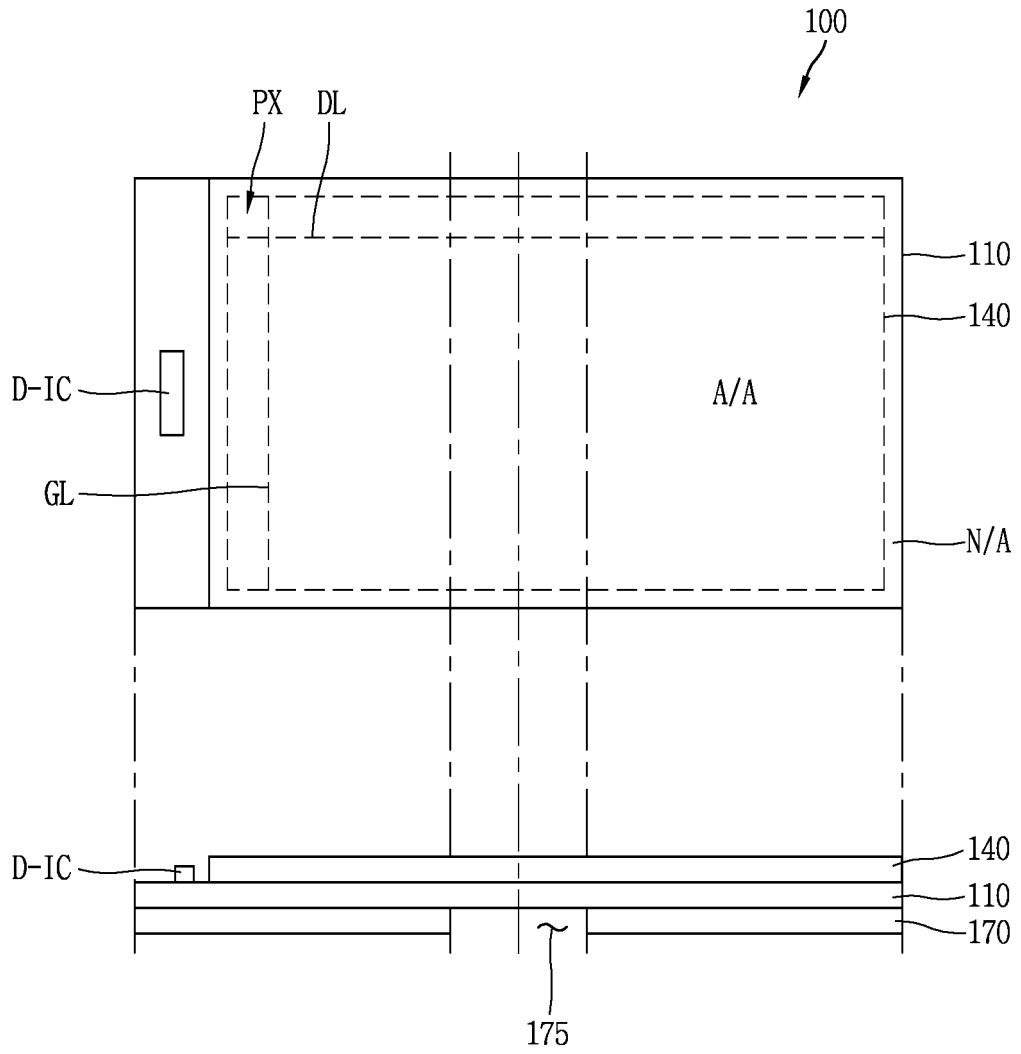

FIG. 3

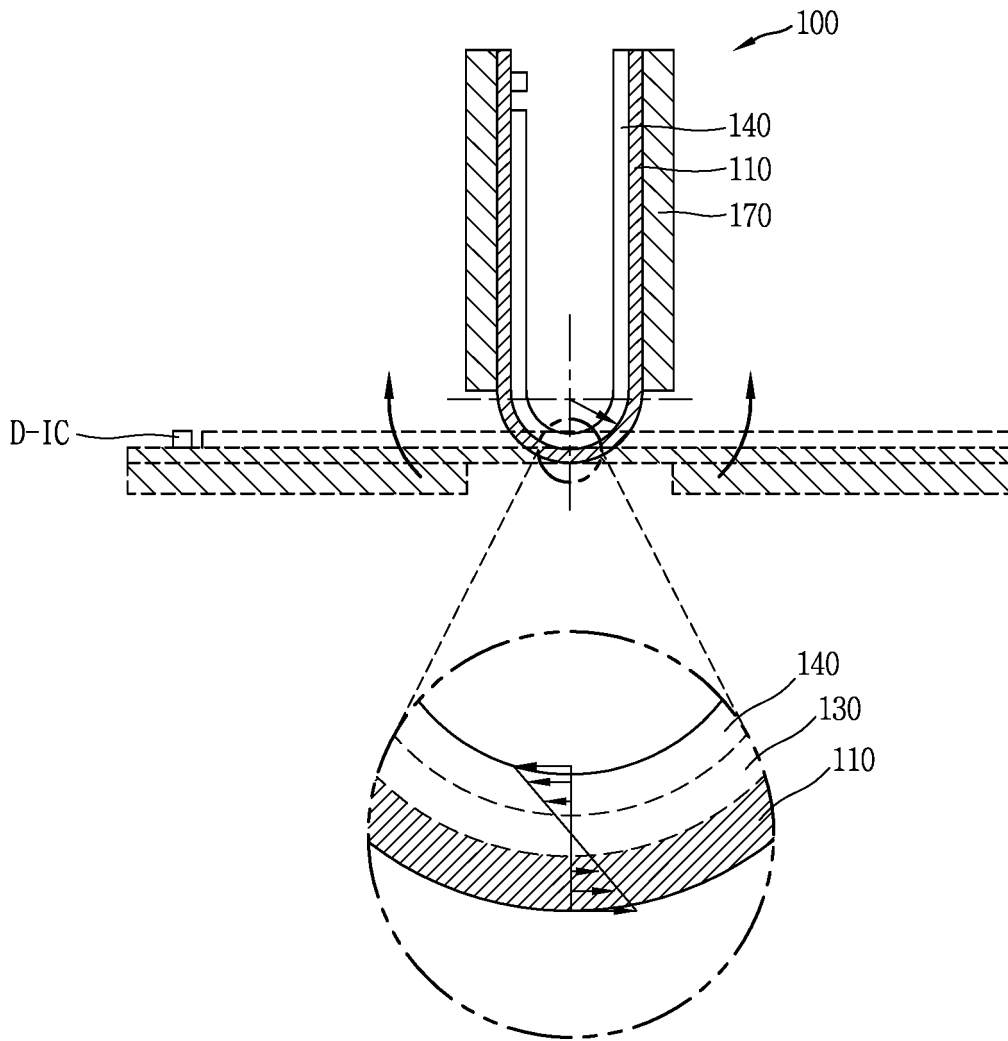

FIG. 4

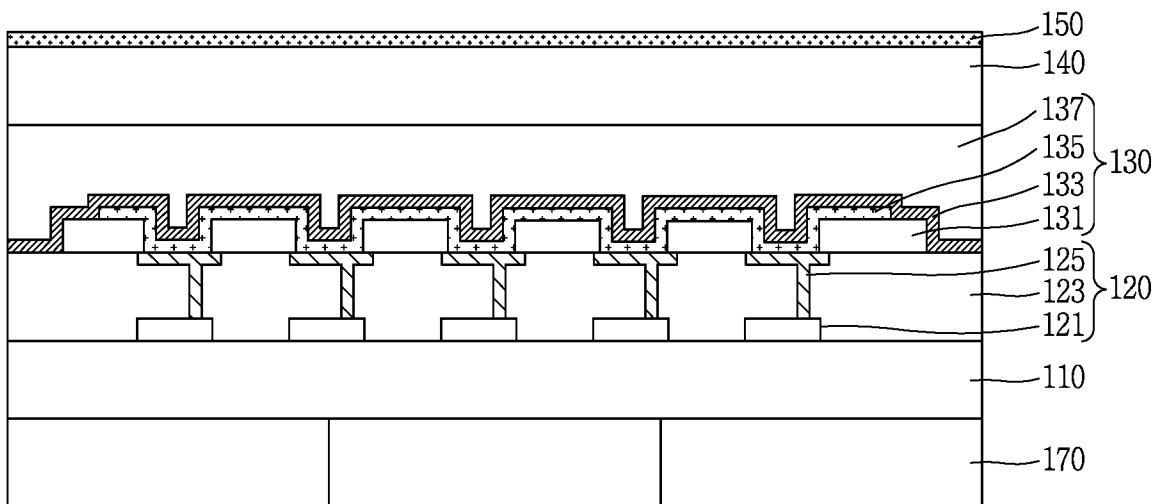

FIG. 5A



FIG. 5B

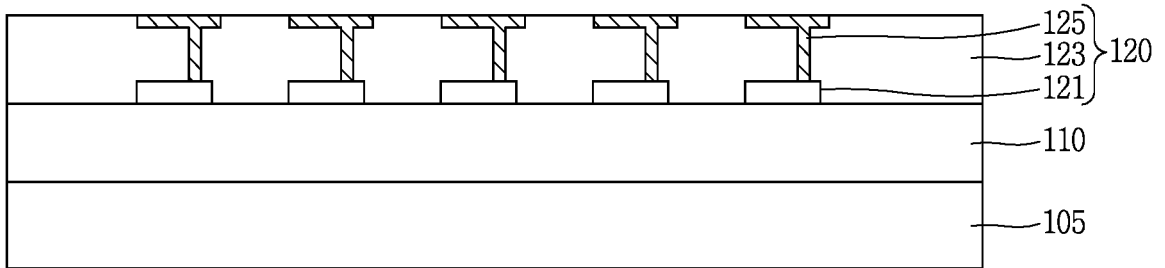

FIG. 5C

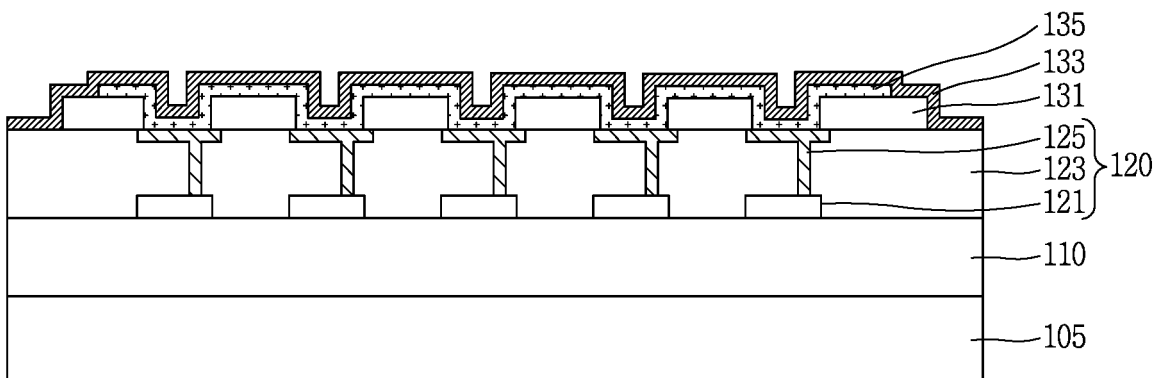

FIG. 5D

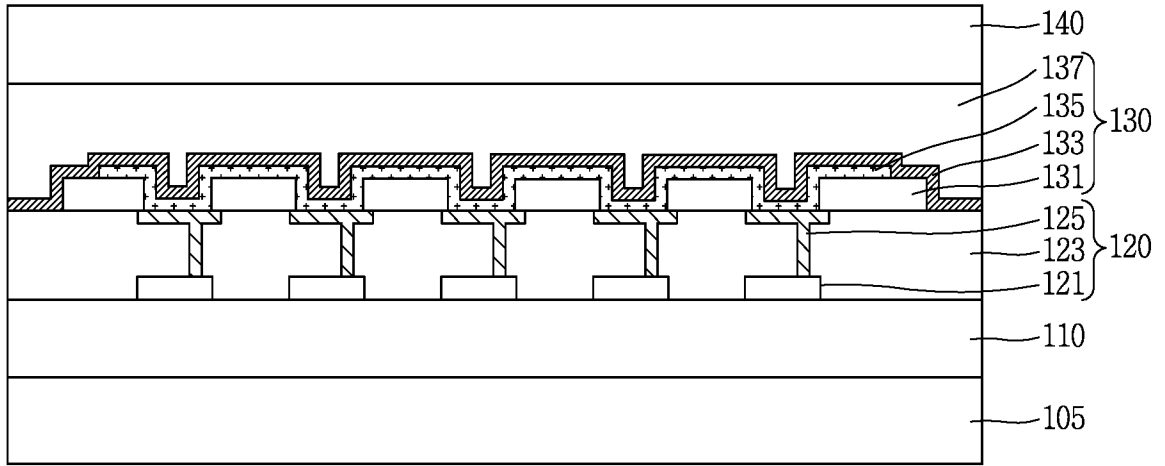

FIG. 5E

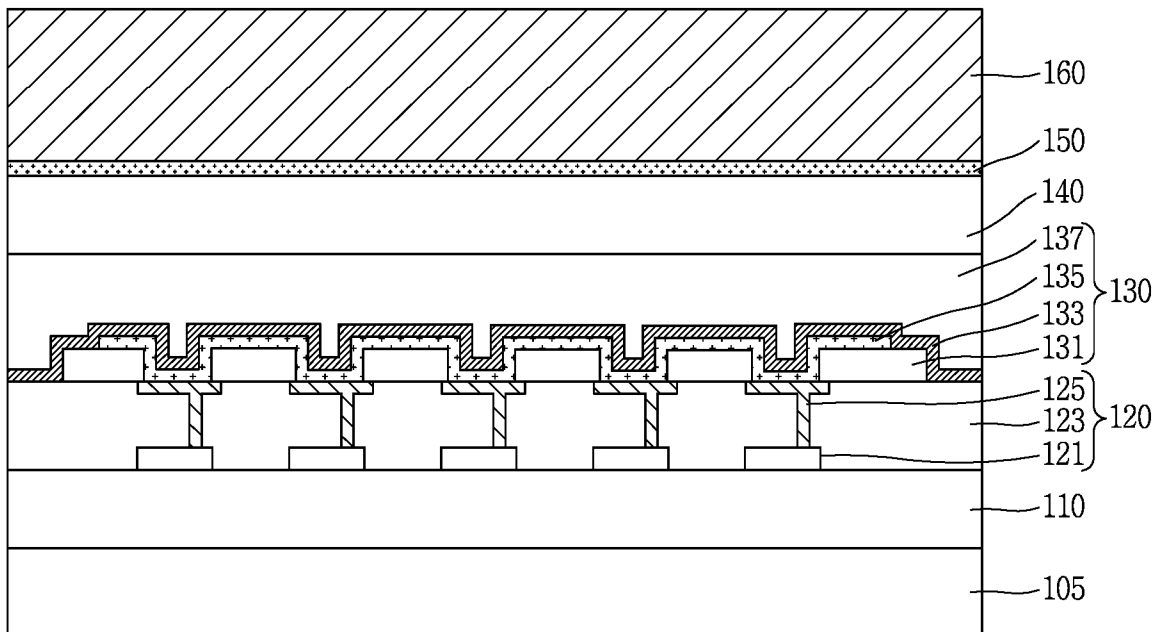

FIG. 5F

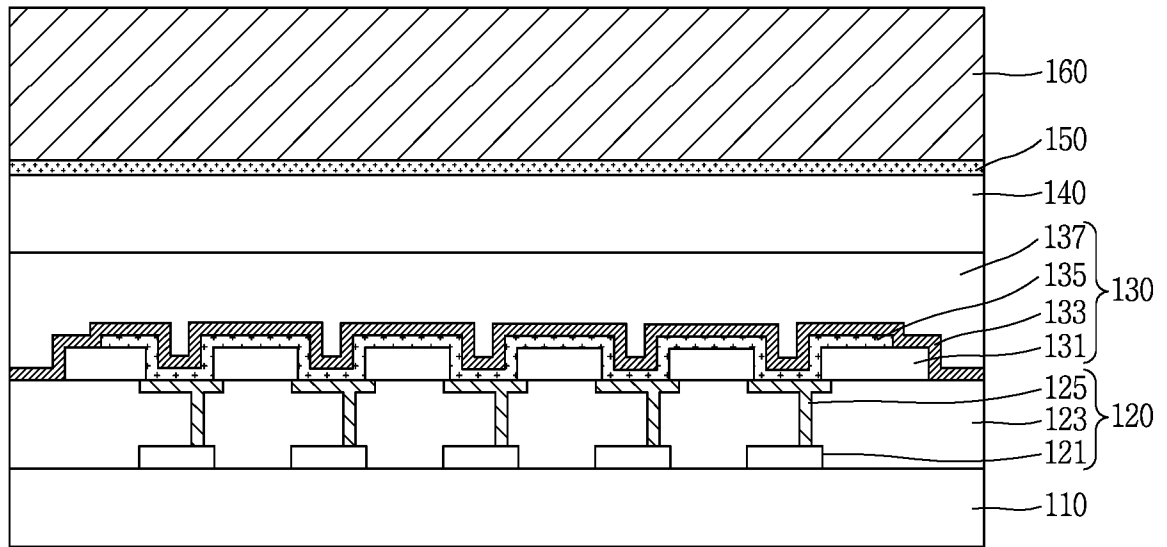

FIG. 5G

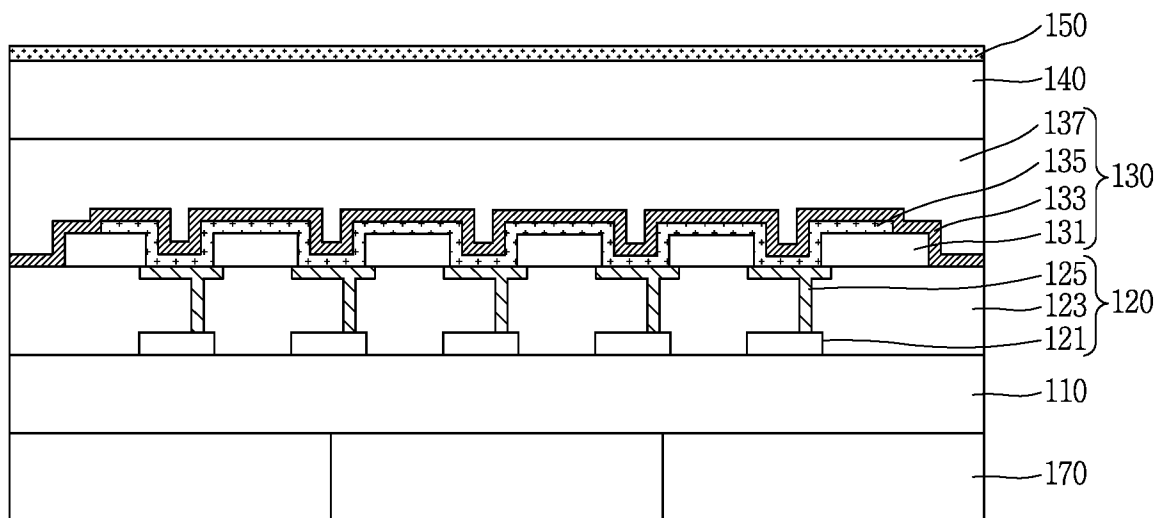
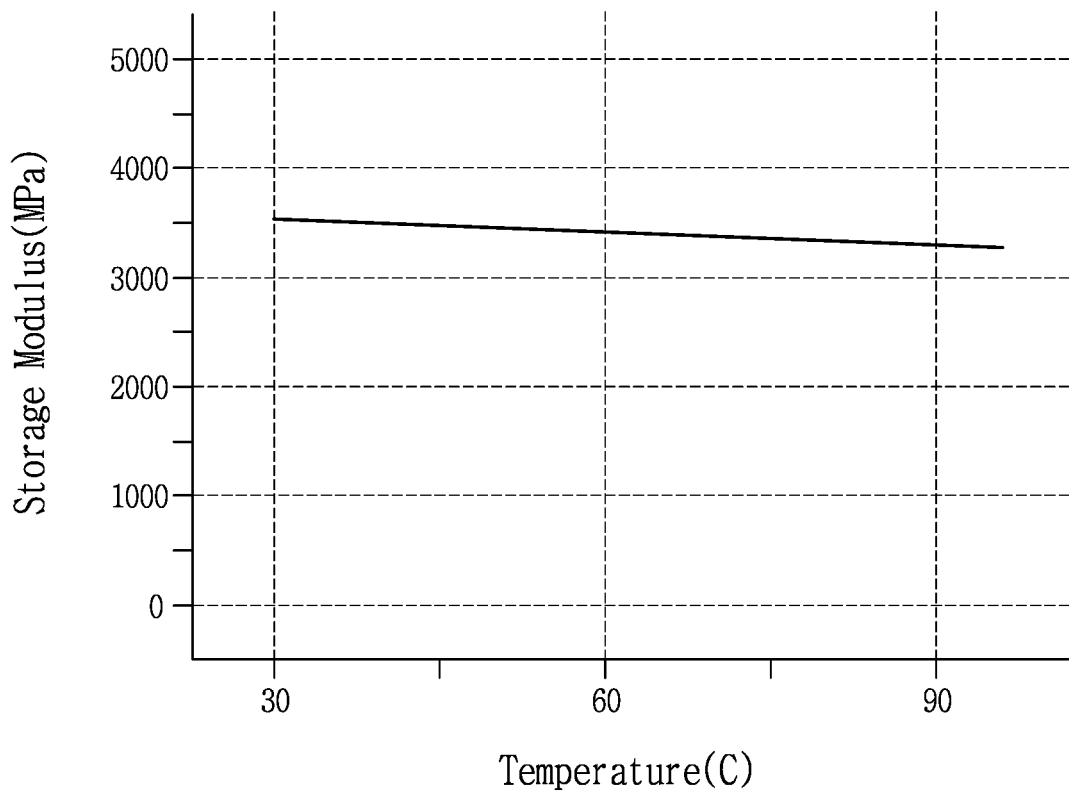

FIG. 6



REFERENCES CITED IN THE DESCRIPTION

This list of references cited by the applicant is for the reader's convenience only. It does not form part of the European patent document. Even though great care has been taken in compiling the references, errors or omissions cannot be excluded and the EPO disclaims all liability in this regard.

Patent documents cited in the description

- EP 1830336 A1 [0008]
- US 20120288685 A1 [0009]
- US 20130076268 A1 [0010]

专利名称(译)	柔性显示装置及其制造方法		
公开(公告)号	EP2983225B1	公开(公告)日	2020-04-01
申请号	EP2015168681	申请日	2015-05-21
[标]申请(专利权)人(译)	乐金显示有限公司		
申请(专利权)人(译)	LG DISPLAY CO. , LTD.		
当前申请(专利权)人(译)	LG DISPLAY CO. , LTD.		
[标]发明人	KIM TAEWOO		
发明人	KIM, TAEWOO		
IPC分类号	H01L51/52 H01L27/32 G09G3/32		
CPC分类号	H01L51/0097 H01L2251/5338 Y02E10/549 Y02P70/521 H01L27/3244 H01L51/003 H01L51/5253 H01L51/5262 H01L51/56 H01L2227/323 H01L2227/326 H01L2251/303 H01L2251/558		
优先权	1020140099996 2014-08-04 KR		
其他公开文献	EP2983225A1		
外部链接	Espacenet		

摘要(译)

在各种实施例中，提供了一种柔性显示设备。柔性显示装置包括基板和
在基板上包括多个晶体管的驱动元件层。柔性显示装置还包括：显示元
件层，其包括电连接至晶体管的有机发光二极管；以及背板膜，该背板
膜附接到基板的背面并且在柔性显示器的中心区域中形成有切口部。设
备。

FIG. 1A

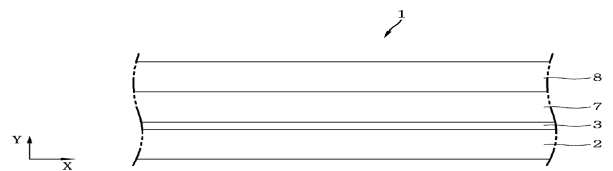

FIG. 1B

