



(11) **EP 2 107 096 A3**

(12) **EUROPEAN PATENT APPLICATION**

(88) Date of publication A3:
14.04.2010 Bulletin 2010/15

(51) Int Cl.:
C09K 11/06^(2006.01) H05B 33/14^(2006.01)

(43) Date of publication A2:
07.10.2009 Bulletin 2009/41

(21) Application number: **09004366.2**

(22) Date of filing: **26.03.2009**

(84) Designated Contracting States:
AT BE BG CH CY CZ DE DK EE ES FI FR GB GR HR HU IE IS IT LI LT LU LV MC MK MT NL NO PL PT RO SE SI SK TR
Designated Extension States:
AL BA RS

- **Suzuki, Tsunenori**
Atsugi-shi
Kanagawa-ken 243-0036 (JP)
- **Ohsawa, Nobuharu**
Atsugi-shi
Kanagawa-ken 243-0036 (JP)
- **Shitagaki, Satoko**
Atsugi-shi
Kanagawa-ken 243-0036 (JP)
- **Seo, Satoshi**
Atsugi-shi
Kanagawa-ken 243-0036 (JP)

(30) Priority: **02.04.2008 JP 2008095796**
16.05.2008 JP 2008129410

(71) Applicant: **SEMICONDUCTOR ENERGY LABORATORY CO., LTD.**
Atsugi-shi, Kanagawa-ken 243-0036 (JP)

(74) Representative: **Grünecker, Kinkeldey, Stockmair & Schwanhäusser**
Anwaltssozietät
Leopoldstrasse 4
80802 München (DE)

(72) Inventors:
• **Kawakami, Sachiko**
Atsugi-shi
Kanagawa-ken 243-0036 (JP)

(54) **Anthracene derivative, light-emitting material, material for light-emitting element, composition for coating, light-emitting element, light-emitting device, and electronic appliance**

(57) A novel anthracene derivative with a large energy gap is provided. An anthracene derivative represented by General Formula (G1) below is provided. In the formula, Ar¹ and Ar² independently represent an aryl group with 6 to 13 carbon atoms in a ring, R¹ and R²

independently represent any of hydrogen, an alkyl group with 1 to 4 carbon atoms, or an aryl group with 6 to 13 carbon atoms in a ring, and each of Ar¹, Ar², R¹, and R² may have a substituent and the two substituents may be bonded to each other to form a ring.

FIG. 1A

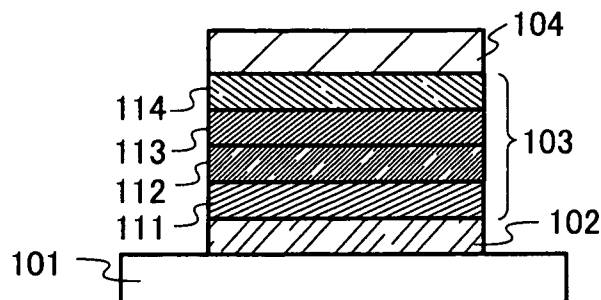

EP 2 107 096 A3

FIG. 1B

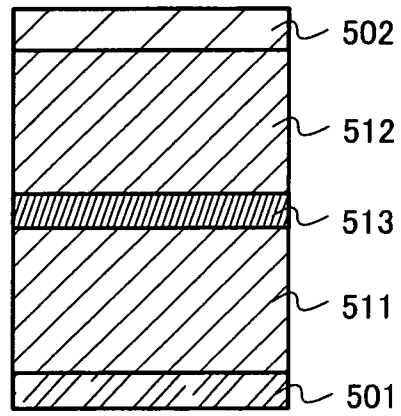



EUROPEAN SEARCH REPORT

Application Number
EP 09 00 4366

DOCUMENTS CONSIDERED TO BE RELEVANT			
Category	Citation of document with indication, where appropriate, of relevant passages	Relevant to claim	CLASSIFICATION OF THE APPLICATION (IPC)
X	US 2007/059556 A1 (KIM KONG K [KR] ET AL) 15 March 2007 (2007-03-15) * page 8 * * claims 1-26 *	1-12	INV. C09K11/06 H05B33/14
X	US 2007/205412 A1 (BAE JAE-SOON [KR] ET AL) 6 September 2007 (2007-09-06) * page 83 * * claims 1-21 *	1-12	
			TECHNICAL FIELDS SEARCHED (IPC)
			C09K
The present search report has been drawn up for all claims			
Place of search		Date of completion of the search	Examiner
The Hague		10 March 2010	Mehdaoui, Imed
<p>CATEGORY OF CITED DOCUMENTS</p> <p>X : particularly relevant if taken alone Y : particularly relevant if combined with another document of the same category A : technological background O : non-written disclosure P : intermediate document</p> <p>T : theory or principle underlying the invention E : earlier patent document, but published on, or after the filing date D : document cited in the application L : document cited for other reasons</p> <p>& : member of the same patent family, corresponding document</p>			

1
EPO FORM 1503_03.02 (P04C01)

ANNEX TO THE EUROPEAN SEARCH REPORT
ON EUROPEAN PATENT APPLICATION NO.

EP 09 00 4366

This annex lists the patent family members relating to the patent documents cited in the above-mentioned European search report. The members are as contained in the European Patent Office EDP file on
The European Patent Office is in no way liable for these particulars which are merely given for the purpose of information.

10-03-2010

Patent document cited in search report	Publication date	Patent family member(s)	Publication date
US 2007059556 A1	15-03-2007	CN 101263212 A	10-09-2008
		EP 1943323 A1	16-07-2008
		JP 2009508352 T	26-02-2009
		WO 2007061181 A1	31-05-2007
		KR 20070118571 A	17-12-2007

US 2007205412 A1	06-09-2007	CN 101395105 A	25-03-2009
		EP 1991514 A1	19-11-2008
		JP 2009529035 T	13-08-2009
		WO 2007102683 A1	13-09-2007
		KR 20070091540 A	11-09-2007

专利名称(译)	葱衍生物，发光材料，发光元件用材料，涂料用组合物，发光元件，发光装置以及电子设备		
公开(公告)号	EP2107096A3	公开(公告)日	2010-04-14
申请号	EP2009004366	申请日	2009-03-26
[标]申请(专利权)人(译)	株式会社半导体能源研究所		
申请(专利权)人(译)	半导体能源研究所有限公司.		
当前申请(专利权)人(译)	半导体能源研究所有限公司.		
[标]发明人	KAWAKAMI SACHIKO SUZUKI TSUNENORI OHSAWA NOBUHARU SHITAGAKI SATOKO SEO SATOSHI		
发明人	KAWAKAMI, SACHIKO SUZUKI, TSUNENORI OHSAWA, NOBUHARU SHITAGAKI, SATOKO SEO, SATOSHI		
IPC分类号	C09K11/06 H05B33/14		
CPC分类号	C09K11/06 C09K2211/1007 C09K2211/1011 C09K2211/1014 C09K2211/1029 H01L51/0052 H01L51/0072 H05B33/14		
优先权	2008129410 2008-05-16 JP 2008095796 2008-04-02 JP		
其他公开文献	EP2107096B1 EP2107096A2		
外部链接	Espacenet		

摘要(译)

提供了一种具有大能隙的新型葱衍生物。提供由以下通式 (G1) 表示的葱衍生物。在该式中，Ar 1和Ar 2独立地表示环中具有6至13个碳原子的芳基，R 1和R 2独立地表示氢，具有1至4个碳原子的烷基或具有6至13个碳的芳基中的任一个。环中的原子，Ar 1，Ar 2，R 1和R 2中的每一个可以具有取代基，并且两个取代基可以彼此键合形成环。

FIG. 1A

