



(11) **EP 3 640 992 A1**

(12) **EUROPEAN PATENT APPLICATION**

(43) Date of publication:  
**22.04.2020 Bulletin 2020/17**

(51) Int Cl.:  
**H01L 27/32<sup>(2006.01)</sup> H01L 51/52<sup>(2006.01)</sup>**

(21) Application number: **19201442.1**

(22) Date of filing: **04.10.2019**

(84) Designated Contracting States:  
**AL AT BE BG CH CY CZ DE DK EE ES FI FR GB GR HR HU IE IS IT LI LT LU LV MC MK MT NL NO PL PT RO RS SE SI SK SM TR**  
Designated Extension States:  
**BA ME**  
Designated Validation States:  
**KH MA MD TN**

(72) Inventors:  
• **LIM, Jung-Shik**  
**10845 Paju-si, Gyeonggi-do (KR)**  
• **KIM, Sun-Man**  
**10845 Paju-si, Gyeonggi-do (KR)**  
• **LEE, Min-Gyu**  
**10845 Paju-si, Gyeonggi-do (KR)**

(30) Priority: **16.10.2018 KR 20180123316**

(74) Representative: **Viering, Jentschura & Partner mbB**  
**Patent- und Rechtsanwälte**  
**Am Brauhaus 8**  
**01099 Dresden (DE)**

(71) Applicant: **LG Display Co., Ltd.**  
**Seoul 150-721 (KR)**

(54) **DISPLAY APPARATUS HAVING A LIGHT-EMITTING DEVICE**

(57) A display apparatus having a light-emitting device (500) is provided. The display apparatus may include a buffer insulating layer disposed on a path of light emitted from the light-emitting device (500). The buffer insulating layer may have a stacked structure of a first buffer insulating layer (110) having the refractive index which decreases in a direction away from the light-emitting device (500), and a second buffer insulating layer (120)

having the refractive index which increases in a direction away from the light-emitting device (500). Thus, in the display apparatus, the unintended constructive and destructive interference of the light emitted from the light-emitting device (500) may be prevented. Therefore, in the display apparatus, the luminous efficacy may be increased, and the variation of color coordinates may be prevented.

**FIG. 1**

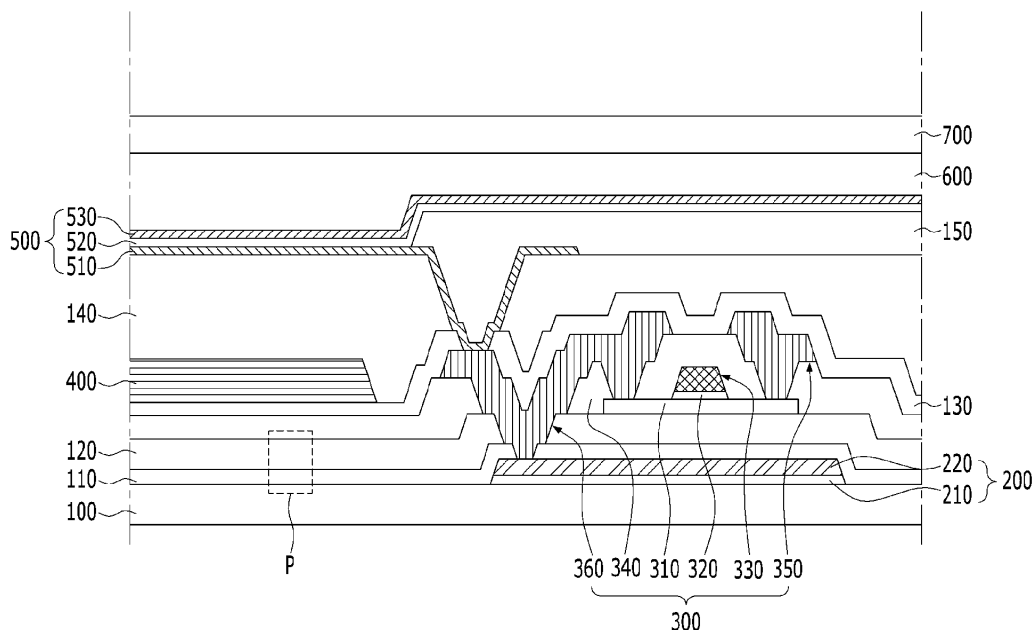

**EP 3 640 992 A1**

## Description

[0001] This application claims the priority benefit of Korean Patent Application No. 10-2018-0123316, filed on October 16, 2018.

## BACKGROUND OF THE INVENTION

### Field of the Invention

[0002] The present invention relates to a display apparatus including insulating layers which are disposed on a path of light generated by a light-emitting device.

### Discussion of the Related Art

[0003] Generally, an electronic appliance, such as a monitor, a TV, a laptop computer and a digital camera, includes a display apparatus to realize an image. For example, the display apparatus may include a light-emitting device which emits light to display a specific color, and a thin film transistor for controlling the light-emitting device.

[0004] The thin film transistor and the light-emitting device may be formed on a device substrate. The device substrate may support the thin film transistor and the light-emitting device. The device substrate may include a transparent material. For example, the light emitted from the light-emitting device may emit outside through the device substrate.

[0005] A buffer insulating layer may be disposed between the device substrate and the thin film transistor, and between the device substrate and the light-emitting device. The buffer insulating layer may prevent the quality deterioration due to the device substrate in the process of forming the light-emitting device.

[0006] However, in the display apparatus, the light emitted from the light-emitting device may be reflected by the difference of the refractive index between the device substrate and the buffer insulating layer, and/or the difference of the refractive index of layers or elements between the device substrate and the light-emitting device, unintentionally. The light unintentionally reflected between the device substrate and the light-emitting device may be re-reflected by an electrode of the light-emitting device and/or an electrode of the thin film transistor. The light re-reflected by the electrode of the light-emitting device and/or the electrode of the thin film transistor may occur the constructive and/or destructive interference with the light which is not reflected between the device substrate and the light-emitting device. Thus, in the display apparatus, the luminance may be decreased or the color coordinates may be changed.

## SUMMARY OF THE INVENTION

[0007] Accordingly, the present invention is directed to a display apparatus that substantially obviates one or

more problems due to limitations and disadvantages of the related art.

[0008] An object of the present invention is to provide a display apparatus capable of preventing the unintended constructive and destructive interference of the light.

[0009] Another object of the present invention is to provide a display apparatus capable of preventing the unintended reflection at the interface between insulating layers which are disposed on the path of the light emitted from the light-emitting device.

[0010] Additional advantages, objects, and features of the invention will be set forth in part in the description which follows and in part will become apparent to those having ordinary skill in the art upon examination of the following or may be learned from practice of the invention. The objectives and other advantages of the invention may be realized and attained by the structure particularly pointed out in the written description and claims hereof as well as the appended drawings.

[0011] To achieve these objects and other advantages and in accordance with the purpose of the invention, as embodied and broadly described herein, there is provided a display apparatus according to claim 1 and a display apparatus according to claim 13. Further embodiments are described in the dependent claims. According to an aspect of the present disclosure, a display apparatus includes a first buffer insulating layer on a device substrate. A second buffer insulating layer is disposed on the first buffer insulating layer. A light-emitting device is disposed on the second buffer insulating layer. The refractive index of the first buffer insulating layer and the refractive index of the second buffer insulating layer decrease in a direction away from an interface between the first buffer insulating layer and the second buffer insulating layer.

[0012] A color filter may be disposed between the second buffer insulating layer and the light-emitting device.

[0013] The first buffer insulating layer may include a first lowest buffer layer disposed close to the device substrate, a first highest buffer layer disposed close to the second buffer insulating layer, and a first intermediate buffer layer between the first lowest buffer layer and the first highest buffer layer. The refractive index of the first intermediate buffer layer may be between the refractive index of the first lowest buffer layer and the refractive index of the first highest buffer layer.

[0014] The refractive index of the first lowest buffer layer may be larger than the refractive index of the device substrate.

[0015] The second buffer insulating layer may include a second lowest buffer layer disposed close to the first buffer insulating layer. The refractive index of the second lowest buffer layer may be smaller than the refractive index of the first highest buffer layer.

[0016] The refractive index of the second lowest buffer layer may be the same as the refractive index of the first intermediate buffer layer.

[0017] The second buffer insulating layer may further include a second highest buffer layer disposed close to

the light-emitting device, and a second intermediate buffer layer between the second lowest buffer layer and the second highest buffer layer. The refractive index of the second intermediate buffer layer may be between the refractive index of the second lowest buffer layer and the refractive index of the second highest buffer layer.

**[0018]** The refractive index of the second intermediate buffer layer may be the same as the refractive index of the first lowest buffer layer.

**[0019]** The refractive index of the second highest buffer layer may be the same as the refractive index of the device substrate.

**[0020]** The thickness of the second highest buffer layer may be larger than the thickness of the second intermediate buffer layer.

**[0021]** In accordance with another aspect of the present disclosure, a display apparatus includes a light-emitting device. The light-emitting device includes a first electrode, a second electrode and a light-emitting layer between the first electrode and the second electrode. A buffer insulating layer is disposed on the first electrode of the light-emitting device. The buffer insulating layer has a stacked structure of a first buffer insulating layer having a refractive index which decreases in a direction away from the light-emitting device, and a second buffer insulating layer having a refractive index which increases in a direction away from the light-emitting device.

**[0022]** The second buffer insulating layer may be disposed between the light-emitting device and the first buffer insulating layer.

**[0023]** The first buffer insulating layer may have a stacked structure of first buffer layers. The second buffer insulating layer may have a stacked structure of second buffer layers. The number of the stacked second buffer layers may be the same as the number of the stacked first buffer layers.

**[0024]** The first buffer layers may have the same thickness.

**[0025]** The variation of the refractive index between the second buffer layers may be symmetrical with the variation of the refractive index between the first buffer layers.

### **BRIEF DESCRIPTION OF THE DRAWINGS**

**[0026]** The accompanying drawings, which are included to provide a further understanding of the invention and are incorporated in and constitute a part of this application, illustrate embodiment(s) of the invention and together with the description serve to explain the principle of the invention. In the drawings:

FIG. 1 is a view schematically showing a display apparatus according to an embodiment of the present invention;

FIG. 2 is an enlarged view of region P in FIG. 1;

FIG. 3 is a graph displaying the spectrum of the light emitted from the light-emitting device according to the distribution of the refractive index in the buffer

insulating layer which is disposed between the device substrate and the light-emitting device;

FIGS. 4 to 7 are views respectively showing the display apparatus according to another embodiment of the present invention;

FIGS. 8 to 10 are graphs respectively displaying the spectrum of the light emitted from the light-emitting device in the blue, green or red sub-pixel according to the presence or absence of stacking the first buffer insulating layer and the second buffer insulating layer between the device substrate and the light-emitting device.

### **DETAILED DESCRIPTION OF THE EMBODIMENTS**

**[0027]** Hereinafter, details related to the above objects, technical configurations, and operational effects of the embodiments of the present invention will be clearly understood by the following detailed description with reference to the drawings, which illustrate some embodiments of the present invention. Here, the embodiments of the present invention are provided in order to allow the technical spirit of the present invention to be satisfactorily transferred to those skilled in the art, and thus the present invention may be embodied in other forms and is not limited to the embodiments described below.

**[0028]** In addition, the same or extremely similar elements may be designated by the same reference numerals throughout the specification, and in the drawings, the lengths and thickness of layers and regions may be exaggerated for convenience. It will be understood that, when a first element is referred to as being "on" a second element, although the first element may be disposed on the second element so as to come into contact with the second element, a third element may be interposed between the first element and the second element.

**[0029]** Here, terms such as, for example, "first" and "second" may be used to distinguish any one element with another element. However, the first element and the second element may be arbitrarily named according to the convenience of those skilled in the art without departing the technical spirit of the present invention.

**[0030]** The terms used in the specification of the present invention are merely used in order to describe particular embodiments, and are not intended to limit the scope of the present invention. For example, an element described in the singular form is intended to include a plurality of elements unless the context clearly indicates otherwise. In addition, in the specification of the present invention, it will be further understood that the terms "comprises" and "includes" specify the presence of stated features, integers, steps, operations, elements, components, and/or combinations thereof, but do not preclude the presence or addition of one or more other features, integers, steps, operations, elements, components, and/or combinations.

**[0031]** Unless otherwise defined, all terms (including technical and scientific terms) used herein have the same

meaning as commonly understood by one of ordinary skill in the art to which example embodiments belong. It will be further understood that terms, such as those defined in commonly used dictionaries, should be interpreted as having a meaning that is consistent with their meaning in the context of the relevant art and should not be interpreted in an idealized or overly formal sense unless expressly so defined herein.

(Embodiment)

**[0032]** FIG. 1 is a view schematically showing a display apparatus according to an embodiment of the present invention. FIG. 2 is an enlarged view of region P in FIG. 1.

**[0033]** Referring to FIGS. 1 and 2, the display apparatus according to the embodiment of the present invention may include a device substrate 100. The device substrate 100 may include an insulating material. The device substrate 100 may include a transparent material. For example, the device substrate 100 may be a glass substrate.

**[0034]** A light-emitting device 500 may be disposed on the device substrate 100. The light-emitting device 500 may emit light displaying a specific color. For example, the light-emitting device 500 may include a first electrode 510, a light-emitting layer 520 and a second electrode 530, which are sequentially stacked.

**[0035]** The first electrode 510 may include a conductive material. The first electrode 510 may include a transparent material. For example, the first electrode 510 may be a transparent electrode formed of a transparent conductive material, such as ITO and IZO.

**[0036]** An edge of the first electrode 510 may be covered by a bank insulating layer 150. The light-emitting layer 520 and the second electrode 530 may be stacked on a portion of the first electrode 510 which is exposed by the bank insulating layer 150. Thus, in the display apparatus according to the embodiment of the present invention, the plurality of the light-emitting devices 500 which are disposed on the device substrate 100 may be insulated by the bank insulating layer 150, each other.

**[0037]** The light-emitting layer 520 may generate light having luminance corresponding to a voltage difference between the first electrode 510 and the second electrode 530. For example, the light-emitting layer 520 may include an emission material layer (EML) having an emission material. The emission material may be an organic material, an inorganic material or a hybrid material. For example, the display apparatus according to the embodiment of the present invention may be an organic light-emitting display apparatus including the light-emitting layer 520 formed of an organic material.

**[0038]** The light-emitting layer 520 may have a multi-layer structure in order to increase luminous efficacy. For example, the light-emitting layer 520 may further include at least one of a hole injection layer (HIL), a hole transporting layer (HTL), an electron transporting layer (ETL) and an electron injection layer (EIL).

**[0039]** The second electrode 530 may include a conductive material. The second electrode 530 may include a material different from the first electrode 510. For example, the second electrode 530 may include a metal having high reflectance, such as aluminum (Al) and silver (Ag). Thus, in the display apparatus according to the embodiment of the present invention, the light generated by the light-emitting layer 520 may be emitted to outside through the first electrode 510 and the device substrate 100.

**[0040]** A driving circuit may be disposed between the device substrate 100 and the light-emitting device 500. The driving circuit may supply a driving current to the light-emitting device 500. The driving circuit may include at least one thin film transistor 300 and a storage capacitor. For example, the driving circuit may include the thin film transistor 300 which is electrically connected to the first electrode 510 of the light-emitting device 500.

**[0041]** The thin film transistor 300 may generate the driving current according to a gate signal and a data signal. For example, the thin film transistor 300 may include a semiconductor pattern 310, a gate insulating layer 320, a gate electrode 330, an interlayer insulating layer 340, a source electrode 350 and a drain electrode 360. The light-emitting device 500 may be connected to the drain electrode 360 of the corresponding thin film transistor 300.

**[0042]** The semiconductor pattern 310 may be disposed close to the device substrate 100. The semiconductor pattern 310 may include a semiconductor material. For example, the semiconductor pattern 310 may include amorphous silicon or poly-crystal silicon. The semiconductor pattern 310 may be oxide semiconductor. For example, the semiconductor pattern 310 may include IGZO.

**[0043]** The semiconductor pattern 310 may include a source region, a drain region and a channel region. The channel region may be disposed between the source region and the drain region. The channel region may have the conductivity lower than the source region and the drain region. For example, the source region and the drain region may have the concentration of a conductive impurity higher than the channel region.

**[0044]** The gate insulating layer 320 may be disposed on the semiconductor pattern 310. An upper surface of the semiconductor pattern 310 opposite to the device substrate 100 may be partially covered by the gate insulating layer 320. For example, the gate insulating layer 320 may overlap the channel region of the semiconductor pattern 310. The source region and the drain region of the semiconductor pattern 310 may be exposed by the gate insulating layer 320.

**[0045]** The gate insulating layer 320 may include an insulating material. For example, the gate insulating layer 320 may include silicon oxide and/or silicon nitride. The gate insulating layer 320 may include a High-K material. For example, the gate insulating layer 320 may include hafnium oxide (HfO) or titanium oxide (TiO). The gate

insulating layer 320 may have a multi-layer structure.

**[0046]** The gate electrode 330 may be disposed on the gate insulating layer 320. The gate electrode 330 may be insulated from the semiconductor pattern 310 by the gate insulating layer 320. For example, the gate electrode 330 may overlap the channel region of the semiconductor pattern 310.

**[0047]** The gate electrode 330 may include a conductive material. For example, the gate electrode 330 may include a metal, such as aluminum (Al), chrome (Cr), molybdenum (Mo) and tungsten (W).

**[0048]** The interlayer insulating layer 340 may be disposed on the semiconductor pattern 310 and the gate electrode 330. The interlayer insulating layer 340 may be extended beyond the semiconductor pattern 310. For example, a side surface of the semiconductor pattern 310 and a side surface of the gate electrode 330 may be covered by the interlayer insulating layer 340.

**[0049]** The interlayer insulating layer 340 may include an insulating material. The refractive index of the interlayer insulating layer 340 may be the same as the refractive index of the device substrate 100. For example, the interlayer insulating layer 340 may include silicon oxide.

**[0050]** The source electrode 350 and the drain electrode 360 may be disposed on the interlayer insulating layer 340. The source electrode 350 may be electrically connected to the source region of the semiconductor pattern 310. The drain electrode 360 may be electrically connected to the drain region of the semiconductor pattern 310. The drain electrode 360 may be spaced away from the source electrode 350. For example, the interlayer insulating layer 340 may include a contact hole exposing the source region of the semiconductor pattern 310, and a contact hole exposing the drain region of the semiconductor pattern 310.

**[0051]** The source electrode 350 and the drain electrode 360 may include a conductive material. For example, the source electrode 350 and the drain electrode 360 may include a metal, such as aluminum (Al), chrome (Cr), molybdenum (Mo) and tungsten (W). The drain electrode 360 may include the same material as the source electrode 350. The gate electrode 330 may include a material different from the source electrode 350 and the drain electrode 360.

**[0052]** The driving circuit may not overlap the portion of the first electrode 510 exposed by the bank insulation layer 150. For example, the thin film transistor 300 may overlap the bank insulating layer 150. Thus, in the display apparatus according to the embodiment of the present invention, the light emitted from the light-emitting device 500 may be not blocked by the thin film transistor 300.

**[0053]** A buffer insulating layer may be disposed between the device substrate 100 and the thin film transistor 300. The buffer insulating layer may prevent the quality deterioration due to the device substrate 100 in the process of forming the thin film transistor 300 and the process of forming the light-emitting device 500. The buffer insulating layer may have a multi-layer structure. For exam-

ple, the buffer insulating layer may include a first buffer insulating layer 110 and a second buffer insulating layer 120, which are sequentially stacked.

**[0054]** The buffer insulating layer may be disposed on the device substrate 100. The buffer insulating layer may prevent the quality deterioration due to the device substrate 100 in subsequent process. The buffer insulating layer may have a multi-layer structure. For example, the buffer insulating layer may have a stacked structure in which a first buffer insulating layer 110 and a second buffer insulating layer 120 are stacked.

**[0055]** The first buffer insulating layer 110 may be disposed close to the device substrate 100. For example, the first buffer insulating layer 110 may be disposed between the device substrate 100 and the second buffer insulating layer 120.

**[0056]** The refractive index of the first buffer insulating layer 110 may increase in a direction away from the device substrate 100. The first buffer insulating layer 110 may include first buffer layers 111, 112 and 113 having different refractive index. For example, the first buffer insulating layer 110 may include a first lowest buffer layer 111, a first intermediate buffer layer 112 and a first highest buffer layer 113, which are sequentially stacked on the device substrate 100. The refractive index of the first highest buffer layer 113 may be larger than the refractive index of the first lowest buffer layer 111. The refractive index of the first intermediate buffer layer 112 may be between the refractive index of the first lowest buffer layer 111 and the refractive index of the first highest buffer layer 113. Also, the refractive index of the first lowest buffer layer 111 may be larger than the refractive index of the device substrate 100.

**[0057]** The first buffer layers 111, 112 and 113 may include an insulating material. At least one of the first buffer layers 111, 112 and 113 may include a different material. For example, the first lowest buffer layer 111 and the first intermediate buffer layer 112 may include silicon oxynitride (SiON), and the first highest buffer layer 113 may include silicon nitride (SiN).

**[0058]** The first buffer layers 111, 112 and 113 may have the same thickness. For example, the thickness TC1 of the first intermediate buffer layer 112 may be the same as the thickness TL1 of the first lowest buffer layer 111. The thickness TU1 of the first highest buffer layer 113 may be the same as the thickness TC1 of the first intermediate buffer layer 112.

**[0059]** The second buffer insulating layer 120 may be disposed on the first buffer insulating layer 110. For example, the second buffer insulating layer 120 may be disposed between the first buffer insulating layer 110 and the light-emitting device 500. The second buffer insulating layer 120 may be in direct contact with an upper surface of the first buffer insulating layer 110 opposite to the device substrate 100. The upper surface of the first buffer insulating layer 110 may be an interface between the first buffer insulating layer 110 and the second buffer insulating layer 120.

**[0060]** The refractive index of the second buffer insulating layer 120 may decrease in a direction away from the first buffer insulating layer 110. Thus, in the display apparatus according to the embodiment of the present invention, the steep change of the refractive index in a path of the light emitted from the light-emitting device 500 may be prevented. The second buffer insulating layer 120 may include second buffer layers 121, 122 and 123 having the different refractive index. For example, the second buffer insulating layer 120 may include a second lowest buffer layer 121, a second intermediate buffer layer 122 and a second highest buffer layer 123, which are sequentially stacked on the first buffer insulating layer 110. The refractive index of the second highest buffer layer 123 may be smaller than the refractive index of the second lowest buffer layer 121. The refractive index of the second intermediate buffer layer 122 may be between the refractive index of the second lowest buffer layer 121 and the refractive index of the second highest buffer layer 123.

**[0061]** The second buffer layers 121, 122 and 123 may include an insulating material. At least one of the second buffer layers 121, 122 and 123 may include a different material. For example, the second lowest buffer layer 121 and the second intermediate buffer layer 122 may include silicon oxynitride (SiON), and the second highest buffer layer 123 may include silicon oxide (SiO).

**[0062]** The variation of the refractive index between the second buffer layers 121, 122 and 123 may be different from the variation of the refractive index between the first buffer layers 111, 112 and 113 with respect to the interface between the first buffer insulating layer 110 and the second buffer insulating layer 120. For example, the refractive index of the second lowest buffer layer 121 may be smaller than the refractive index of the first highest buffer layer 113. The refractive index of the second intermediate buffer layer 122 may be smaller than the refractive index of the first intermediate buffer layer 112. The refractive index of the second highest buffer layer 123 may be smaller than the refractive index of the first lowest buffer layer 111.

**[0063]** The first buffer layers 111, 112 and 113 and the second buffer layers 121, 122 and 123 may have the refractive index symmetrical with respect to the first highest buffer layer 113. For example, the refractive index of the second lowest buffer layer 121 may be the same as the refractive index of the first intermediate buffer layer 112. The thickness TL2 of the second lowest buffer layer 121 may be the same as the thickness TC1 of the first intermediate buffer layer 112. The refractive index of the second intermediate buffer layer 122 may be the same as the refractive index of the first lowest buffer layer 111. The thickness TC2 of the second intermediate buffer layer 122 may be the same as the thickness TL1 of the first lowest buffer layer 111. The refractive index of the second highest buffer layer 123 may be the same as the refractive index of the device substrate 100. The thickness TU2 of the second highest buffer layer 123 may be larger than

the thickness TC2 of the second intermediate buffer layer 122.

**[0064]** A light-blocking pattern 200 may be disposed between the device substrate 100 and the first buffer insulating layer 110. The light-blocking pattern 200 may block the light incident from the outside. For example, the semiconductor pattern 310 of the thin film transistor 300 may overlap the light-blocking pattern 200. A horizontal width of the light-blocking pattern 200 may be larger than a horizontal width of the semiconductor pattern 310. Thus, in the display apparatus according to the embodiment of the present invention, an external light toward the channel region of the semiconductor pattern 310 may be blocked by the light-blocking pattern 200. Therefore, in the display apparatus according to the embodiment of the present invention, the malfunction of the thin film transistor 300 due to the external light may be prevented.

**[0065]** The light-blocking pattern 200 may have a multi-layer structure. For example, the light-blocking pattern 200 may include a low-reflective layer 210 and the light-blocking layer 220, which are sequentially stacked on the device substrate 100. The low-reflective layer 210 may include a low-reflective material. For example, the low-reflective layer 210 may include a low-reflective metal, such as molybdenum (Mo), chrome (Cr), titanium (Ti) and tantalum (Ta). The light-blocking layer 220 may include a conductive material. The reflectance of the light-blocking layer 220 may be larger than the reflectance of the low-reflective layer 210. For example, the light-blocking layer 220 may include a metal, such as aluminum (Al) and silver (Ag). Thus, in the display apparatus according to the embodiment of the present invention, the visibility deterioration due to the light reflected by the light-blocking layer 220 may be prevented.

**[0066]** The light-blocking pattern 200 may be electrically connected to the driving circuit. For example, the drain electrode 360 of the thin film transistor 300 may be connected to the light-blocking layer 220 of the light-blocking pattern 200. The first buffer insulating layer 110 and the second buffer insulating layer 120 may include a contact hole exposing a portion of the light-blocking layer 220. Thus, in the display apparatus according to the embodiment of the present invention, the parasitic capacitance due to the light-blocking pattern 200 may be prevented.

**[0067]** A lower passivation layer 130 may be disposed on an upper surface of the thin film transistor 300 opposite to the device substrate 100. The lower passivation layer 130 may prevent the damage of the thin film transistor 300 due to the external impact and moisture. For example, the lower passivation layer 130 may be extended beyond the source electrode 350 and the drain electrode 360. The thin film transistor 300 may be covered by the lower passivation layer 130, substantially.

**[0068]** The lower passivation layer 130 may include an insulating material. The lower passivation layer 130 may be direct contact with the interlayer insulating layer 340

on the outside of the source electrode 350 and the drain electrode 360. The lower passivation layer 130 may include the same material as the interlayer insulating layer 340. For example, the lower passivation layer 130 may include silicon oxide.

**[0069]** An over-coat layer 140 may be disposed between the lower passivation layer 130 and the light-emitting device 500, and between the lower passivation layer 130 and the bank insulating layer 150. The over-coat layer 140 may remove a thickness difference due to the light-blocking pattern 200 and the thin film transistor 300. For example, an upper surface of the over-coat layer 140 opposite to the device substrate 100 may be a flat surface.

**[0070]** The over-coat layer 140 may include an insulating material. The over-coat layer 140 may include a relative fluid material. For example, the over-coat layer 140 may include an organic insulating material.

**[0071]** A color filter 400 may be disposed on the path of the light emitted from the light-emitting device 500. For example, the color filter 400 may be disposed between the lower passivation layer 130 and the over-coat layer 140. A thickness difference due to the color filter 400 may be removed by the over-coat layer 140.

**[0072]** The color realized by the light which is emitted from the light-emitting device may be changed by the color filter 400. For example, the light which is emitted from the light-emitting device 500 and displays white color may realize blue color, red color or green color by the color filter 400. The color filter 400 may overlap the portion of the first electrode 510 exposed by the bank insulating layer 150. The color filter 400 may not overlap the thin film transistor 300. A horizontal width of the color filter 400 may be larger than a horizontal width of the portion of the first electrode 510 exposed by the bank insulating layer 150. Thus, in the display apparatus according to the embodiment of the present invention, all of the light emitted from the light-emitting device 500 may pass through the color filter 400. Therefore, in the display apparatus according to the embodiment of the present invention, the light leakage may be prevented.

**[0073]** An encapsulating layer 600 may be disposed on the second electrode 530 of the light-emitting device 500. The encapsulating layer 600 may prevent the damage of the light-emitting device 500 due to the external impact and moisture. For example, the encapsulating layer 600 may completely cover the light-emitting devices 500 which are disposed on the device substrate 100. The encapsulating layer 600 may include moisture-absorbing beads formed of a moisture-absorbing material. The encapsulating layer 600 may have a multi-layer structure. For example, the encapsulating layer 600 may include a lower encapsulating layer and an upper encapsulating layer, which are sequentially stacked on the light-emitting device 500. The moisture-absorbing beads may be dispersed in the upper encapsulating layer. The lower encapsulating layer may be disposed between the light-emitting device 500 and the upper encapsulating layer.

Thus, in the display apparatus according to the embodiment of the present invention, the stress applied to the light-emitting device 500 due to expansion of the moisture-absorbing beads may be relieved by the lower encapsulating layer.

**[0074]** The encapsulating layer 600 may include an insulating material. The encapsulating layer 600 may include a material which does not need a curing process. For example, the encapsulating layer 600 may include an olefin-based material. Thus, in the display apparatus according to the embodiment of the present invention, the deterioration of the light-emitting device 500 due to the process of forming the encapsulating layer 600 may be prevented. The lower encapsulating layer may include a material different from the upper encapsulating layer.

**[0075]** The display apparatus according to the embodiment of the present invention is described as having the encapsulating layer 600 in direct contact with the light-emitting device 500. However, the display apparatus according to another embodiment of the present invention may further include an upper passivation layer between the second electrode 530 of the light-emitting device 500 and the encapsulating layer 600. The upper passivation layer may prevent the damage of the light-emitting device 500 due to the external impact and moisture. The upper passivation layer may include an insulating material. The upper passivation layer may have a multi-layer structure. The upper passivation layer may include a material different from the encapsulating layer 600. For example, the upper passivation layer may have a structure in which an organic insulating layer formed of an organic material is disposed between inorganic insulating layers which are formed of an inorganic material. Thus, in the display apparatus according to another embodiment of the present invention, the damage of the light-emitting device 500 due to the external impact and moisture may be efficiently prevented.

**[0076]** An encapsulation substrate 700 may be disposed on the encapsulating layer 600. The encapsulation substrate 700 may be coupled with the device substrate 100 on which the light-emitting device 500 is formed, by the encapsulating layer 600. The encapsulation substrate 700 may include a material different from the device substrate 100. The encapsulation substrate 700 may dissipate heat generated by the light-emitting device 500 and/or the thin film transistor 300 in the operation of realizing the image. For example, the encapsulation substrate 700 may include a metal having a relatively high thermal conductivity, such as aluminum (Al).

**[0077]** Accordingly, the display apparatus according to the embodiment of the present invention may include the first buffer insulating layer 110 and the second buffer insulating layer 120 which are stacked between the device substrate 100 and the light-emitting device 500. The first buffer insulating layer 110 may have the refractive index decreasing in a direction away from the light-emitting device 500. The second buffer insulating layer 120 may have the refractive index increasing in the direction away

from the light-emitting device 500. Thus, in the display apparatus according to the embodiment of the present invention, the difference of the refractive index between insulating layers which are stacked on the path of the light emitted to the outside through the device substrate 100 may be minimized. Therefore, in the display apparatus according to the embodiment of the present invention, the steep change of the refractive index between the buffer insulating layer and the peripheral element may be prevented. Thereby, in the display apparatus according to the embodiment of the present invention, the unintended reflection due to the buffer insulating layer may be prevented.

**[0078]** FIG. 3 is a graph displaying the spectrum of the light emitted from the light-emitting device 500 according to the distribution of the refractive index in the buffer insulating layer which is disposed between the device substrate 100 and the light-emitting device 500. Herein, S1 is a graph displaying the spectrum of the display apparatus according to the embodiment of the present invention. S2 is a graph displaying the spectrum of the display apparatus including the buffer insulating layer which has the refractive index decreasing in a direction toward the light-emitting device from the device substrate. S3 is a graph displaying the spectrum of the display apparatus including the buffer insulating layer which has the refractive index increasing in a direction toward the light-emitting device from the device substrate.

**[0079]** Referring to FIG. 3, the graph wiggling of S1 is smaller than the graph wiggling of S2 and S3. That is, the display apparatus according to the embodiment of the present invention may prevent the unintended constructive and destructive interference of the light emitted from the light-emitting device 500 by the stacked structure of the first buffer insulating layer 110 and the second buffer insulating layer 120, which have the refractive index decreasing in a direction away from the interface between the first buffer insulating layer 110 and the second buffer insulating layer 120. Thus, in the display apparatus according to the embodiment of the present invention, the characteristics distribution of the light according to the position may be prevented. Therefore, in the display apparatus according to the embodiment of the present invention, the luminous efficacy may be increased, and the variation of color coordinates may be prevented.

**[0080]** The display apparatus according to the embodiment of the present invention is described under that assumption that the second lowest buffer layer 121 of the second buffer insulating layer 120 has the refractive index smaller than the first highest buffer layer 113 of the first buffer insulating layer 110. However, in the display apparatus according to another embodiment of the present invention, the variation of the refractive index between the second buffer layers 121, 122 and 123 may be symmetrical with the variation of the refractive index between the first buffer layers 111, 112 and 113 with respect to the interface between the first buffer insulating

layer 110 and the second buffer insulating layer 120. For example, in the display apparatus according to another embodiment of the present invention, the refractive index of the second lowest buffer layer 121, the second intermediate buffer layer 122 and the second highest buffer layer 123 of the second buffer insulating layer 120 may be the same as the refractive index of the first highest buffer layer 113, the first intermediate buffer layer 112 and the first lowest buffer layer 111 of the first buffer insulating layer 110, respectively. Thus, in the display apparatus according to another embodiment of the present invention, the thickness TU2 of the second highest buffer layer 123 may be the same as the thickness TL1 of the first lowest buffer layer 111, the thickness TC2 of the second intermediate buffer layer 122 may be the same as the thickness TC1 of the first intermediate buffer layer 112, and the thickness TL2 of the second lowest buffer layer 121 may be the same as the thickness TU1 of the first highest buffer layer 113, as shown in FIG. 4. Therefore, in the display apparatus according to another embodiment of the present invention, the wiggling of the spectrum may be minimized, and the quality deterioration due to the device substrate 100 may be efficiently prevented.

**[0081]** The display apparatus according to the embodiment of the present invention is described under the assumption that the first buffer layers 111, 112 and 113 have the same thickness ( $TL1=TC1=TU1$ ). However, in the display apparatus according to another embodiment of the present invention, the first buffer layers 111, 112 and 113 have different thicknesses. In other words the thicknesses differ from each other. For example, in the display apparatus according to another embodiment of the present invention, the thickness TL1 of the first lowest buffer layer 111 may be smaller than the thickness TU1 of the first highest buffer layer 113, the thickness TC1 of the first intermediate buffer layer 112 may be between the thickness TL1 of the first lowest buffer layer 111 and the thickness TU1 of the first highest buffer layer 113, as shown in FIG. 5. Also, in the display apparatus according to another embodiment of the present invention, the second buffer layers 121, 122 and 123 may have the thickness corresponding to the first buffer layers 111, 112 and 113. Thus, in the display apparatus according to another embodiment of the present invention, the degree of freedom in the configuration of the buffer insulating layer may be improved.

**[0082]** The display apparatus according to the embodiment of the present invention is described under the assumption that the gate electrode 330, the source electrode 350 and the drain electrode 360 of the thin film transistor 300 have a single layer structure. However, in the display apparatus according to another embodiment of the present invention, the thin film transistor 300 may include the gate electrode 330, the source electrode 350 and the drain electrode 360 which have a multi-layer structure, as shown in FIG. 6. For example, the gate electrode 330 may include a lower gate layer 331 and an

upper gate layer 332, the source electrode 350 may include a lower source layer 351 and an upper source layer 352, and the drain electrode 360 may include a lower drain layer 361 and an upper drain layer 362. The lower gate layer 331, the lower source layer 351 and the lower drain layer 361 may include a low-reflective material. For example, the lower gate layer 331, the lower source layer 351 and the lower drain layer 361 may include a low-reflective metal, such as molybdenum (Mo), chrome (Cr), titanium (Ti) and tantalum (Ta). The upper gate layer 332, the upper source layer 352 and the upper drain layer 362 may have the conductivity higher than the lower gate layer 331, the lower source layer 351 and the lower drain layer 361, respectively.

**[0083]** The display apparatus according to the embodiment of the present invention is described under the assumption that the interlayer insulating layer 340 of the thin film transistor 300 is extended between the second buffer insulating layer 120 and the lower passivation layer 130. However, in the display apparatus according to another embodiment of the present invention, the lower passivation layer 130 may be in direct contact with the second buffer insulating layer 120 between the device substrate 100 and the color filter 400, as shown in FIG. 6. For example, in the display apparatus according to another embodiment of the present invention, a portion of the interlayer insulating layer 340 may be removed by using a mask in the process of forming the source electrode 350 and the drain electrode 360. Thus, in the display apparatus according to another embodiment of the present invention, the degree of freedom in a material of the interlayer insulating layer 340 may be improved. For example, in the display apparatus according to another embodiment of the present invention, the refractive index of the interlayer insulating layer 340 may be very different from the refractive index of the lower passivation layer 130. Thus, in the display apparatus according to another embodiment of the present invention, the function of the interlayer insulating layer 340 may be sufficiently performed, and the variation of the color coordinates may be prevented.

**[0084]** The display apparatus according to the embodiment of the present invention is described under the assumption that the light-emitting layer 520 and the second electrode 530 of the light-emitting device 500 may be extended onto the bank insulating layer 150. That is, in the display apparatus according to the embodiment of the present invention, the light-emitting layer 520 of each light-emitting device 500 may be connected to the light-emitting layer 520 of adjacent light-emitting device 500. However, in the display apparatus according to another embodiment of the present invention, each of the light-emitting devices 500 may include the light-emitting layer 520 separated from adjacent light-emitting devices 500, as shown in FIG. 7. For example, in the display apparatus according to another embodiment of the present invention, the light-emitting device 500 disposed on a blue sub-pixel may include a blue light-emitting layer 520, the light-

emitting device 500 disposed on a green sub-pixel may include a green light-emitting layer 520, and the light-emitting device 500 disposed on a red sub-pixel may include a red light-emitting layer 520.

**[0085]** FIG. 8 is a graph displaying the spectrum of the light emitted from the light-emitting device on the blue sub-pixel according to the presence or absence of stacking the first buffer insulating layer and the second buffer insulating layer between the device substrate and the light-emitting device. FIG. 9 is a graph displaying the spectrum of the light emitted from the light-emitting device on the green sub-pixel according to the presence or absence of stacking the first buffer insulating layer and the second buffer insulating layer between the device substrate and the light-emitting device. FIG. 10 is a graph displaying the spectrum of the light emitted from the light-emitting device on the red sub-pixel according to the presence or absence of stacking the first buffer insulating layer and the second buffer insulating layer between the device substrate and the light-emitting device.

**[0086]** Referring to FIGS. 9-10, the display apparatus B1, G1 and R1 including the first buffer insulating layer and the second buffer insulating layer which are stacked between the device substrate and the light-emitting device of the blue, green or red sub-pixel may have the wiggling of the graph smaller than the display apparatus B2, G2 and R2 including the buffer insulating layer having the specific refractive index. That is, in the display apparatus according to another embodiment of the present invention, the luminous efficacy of the light-emitting device having the light-emitting layer separated from adjacent light-emitting device may be increased, and the variation of the color coordinates due to constructive/destructive interference between the reflected lights may be prevented. For example, in the display apparatus according to another embodiment of the present invention, the color coordinates may be optimized by adjusting the stacked structure of the first buffer insulating layer and the second buffer insulating layer of the display apparatus. Thus, in the display apparatus according to another embodiment of the present invention, the quality of the realized image may be improved.

**[0087]** In the result, the display apparatus according to the embodiments of the present invention may prevent the steep change of the refractive index due to the buffer insulating layer which is disposed between the device substrate and the light-emitting device. Thus, in the display apparatus according to the embodiments of the present invention, the light emitted from the light-emitting device may not be reflected by the difference of the refractive index between adjacent insulating layers. That is, in the display apparatus according to the embodiments of the present invention, the unintended constructive and destructive interference of the light may be prevented. Therefore, in the display apparatus according to the embodiments of the present invention, the luminous efficacy may be increased, and the variation of color coordinates may be prevented.

**Claims****1.** A display apparatus comprising:

a device substrate (100);  
 a first buffer insulating layer (110) on the device substrate (100);  
 a second buffer insulating layer (120) on the first buffer insulating layer (110); and  
 a light-emitting device (500) on the second buffer insulating layer (120),  
 wherein the refractive index of the first buffer insulating layer (110) and the refractive index of the second buffer insulating layer (120) decrease in a direction away from the interface between the first buffer insulating layer (110) and the second buffer insulating layer (120).

**2.** The display apparatus according to claim 1, wherein the first buffer insulating layer (110) includes a first lowest buffer layer (111) disposed on the device substrate (100), a first intermediate buffer layer (112) disposed on the first lowest buffer layer (111), and a first highest buffer layer (113) disposed on the first intermediate buffer layer (112),  
 wherein the refractive index of the first intermediate buffer layer (112) is between the refractive index of the first lowest buffer layer (111) and the refractive index of the first highest buffer layer (113).

**3.** The display apparatus according to claim 2, wherein the refractive index of the first lowest buffer layer (111) is larger than the refractive index of the device substrate (100).

**4.** The display apparatus according to claim 2 or 3, wherein the first lowest buffer layer (111), the first intermediate buffer layer (112) and the first highest buffer layer (113) have the same thickness.

**5.** The display apparatus according to any one of claims 2 to 4, wherein the second buffer insulating layer (120) includes a second lowest buffer layer (121) disposed on the first buffer insulating layer (110), and wherein the refractive index of the second lowest buffer layer (121) is smaller than the refractive index of the first highest buffer layer (113).

**6.** The display apparatus according to claim 5, wherein the refractive index of the second lowest buffer layer (121) is the same as the refractive index of the first intermediate buffer layer (112).

**7.** The display apparatus according to claim 5 or 6, wherein the second buffer insulating layer (120) further includes a second intermediate buffer layer (122) disposed on the second lowest buffer layer (121), and a second highest buffer layer (123) dis-

posed on the second intermediate buffer layer (122), wherein the refractive index of the second intermediate buffer layer (122) is between the refractive index of the second lowest buffer layer (121) and the refractive index of the second highest buffer layer (123).

**8.** The display apparatus according to claim 7, wherein the refractive index of the second intermediate buffer layer (122) is the same as the refractive index of the first lowest buffer layer (111).

**9.** The display apparatus according to claim 7 or 8, wherein the refractive index of the second highest buffer layer (123) is the same as the refractive index of the device substrate (100).

**10.** The display apparatus according to claim 7, wherein the refractive index of the device substrate (100) is the same as the refractive index of the second highest buffer layer (123), the refractive index of the first lowest buffer layer (111) is the same as the refractive index of the second intermediate buffer layer (122), and the refractive index of the first intermediate buffer layer (112) is the same as the refractive index of the second lowest buffer layer (121), wherein, preferably, the thickness of the device substrate (100) is the same as the thickness (TU2) of the second highest buffer layer (123), the thickness (TL1) of the first lowest buffer layer (111) is the same as the thickness (TC2) of the second intermediate buffer layer (122), and the thickness (TC1) of the first intermediate buffer layer (112) is the same as the thickness (TL2) of the second lowest buffer layer (121).

**11.** The display apparatus according to claim 7, wherein the refractive index of the first lowest buffer layer (111) is the same as the refractive index of the second highest buffer layer (123), the refractive index of the first intermediate buffer layer (112) is the same as the refractive index of the second intermediate buffer layer (122), and the refractive index of the first highest buffer layer (113) is the same as the refractive index of the second lowest buffer layer (121), wherein, preferably, the thickness (TL1) of the first lowest buffer layer (111) is the same as the thickness (TU2) of the second highest buffer layer (123), the thickness (TC1) of the first intermediate buffer layer (112) is the same as the thickness (TC2) of the second intermediate buffer layer (122), and the thickness (TU1) of the first highest buffer layer (113) is the same as the thickness (TL2) of the second lowest buffer layer (121).

**12.** The display apparatus according to claim 7, wherein the thickness (TU2) of the second highest buffer layer (123) is larger than the thickness (TC2) of the second intermediate buffer layer (122).

13. A display apparatus comprising:

a light-emitting device including a first electrode,  
 a second electrode and a light-emitting layer be- 5  
 tween the first electrode and the second elec-  
 trode; and  
 a buffer insulating layer on the first electrode of  
 the light-emitting device,  
 wherein the buffer insulating layer has a stacked 10  
 structure of a first buffer insulating layer having  
 a refractive index which decreases in a direction  
 away from the light-emitting device, and a sec-  
 ond buffer insulating layer having a refractive 15  
 index which increases in a direction away from  
 the light-emitting device.

14. The display apparatus according to claim 13, where-  
 in the second buffer insulating layer is disposed be- 20  
 tween the light-emitting device and the first buffer  
 insulating layer.

15. The display apparatus according to claim 13 or 14,  
 wherein the first buffer insulating layer has a stacked 25  
 structure of first buffer layers, and the second buffer  
 insulating layer has a stacked structure of second  
 buffer layers, and  
 wherein the number of the stacked second buffer  
 layers is the same as the number of the stacked first 30  
 buffer layers, wherein, preferably, the first buffer lay-  
 ers have the same thickness and/or the variation of  
 the refractive index between the second buffer layers  
 is symmetrical with the variation of the refractive in-  
 dex between the first buffer layers.

5

10

15

20

25

30

35

40

45

50

55

FIG. 1

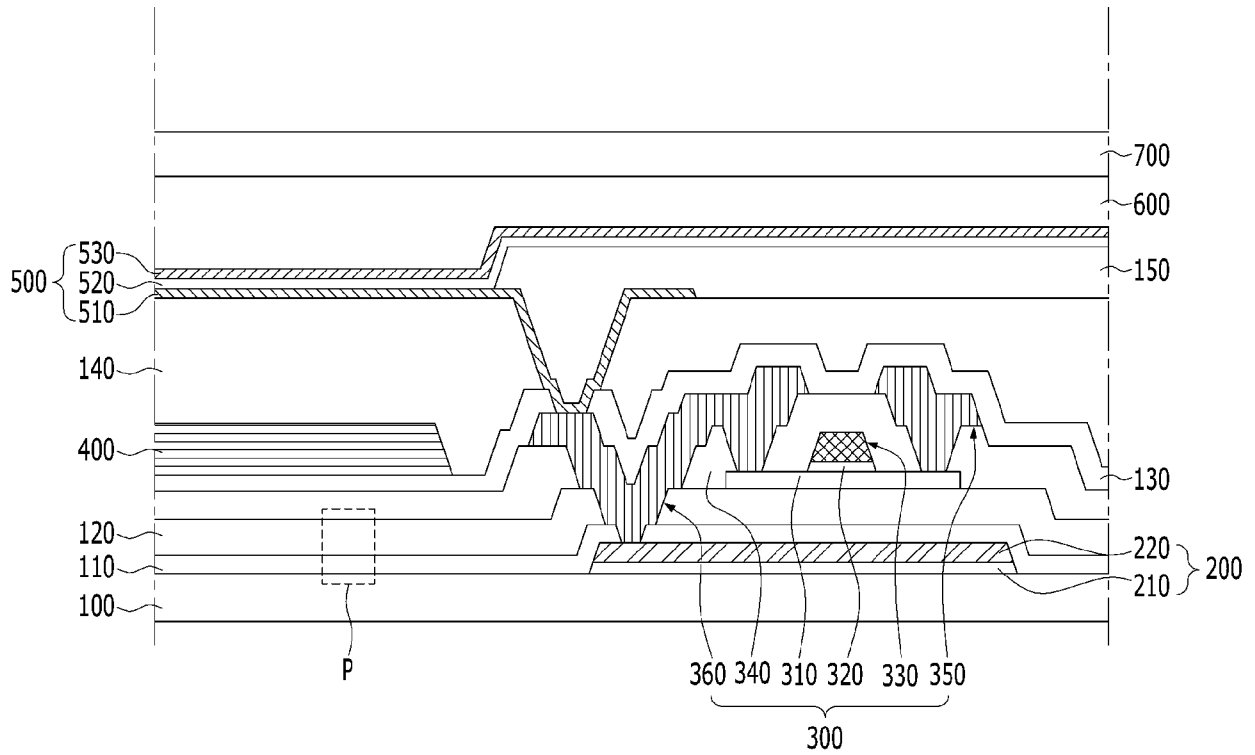

FIG. 2

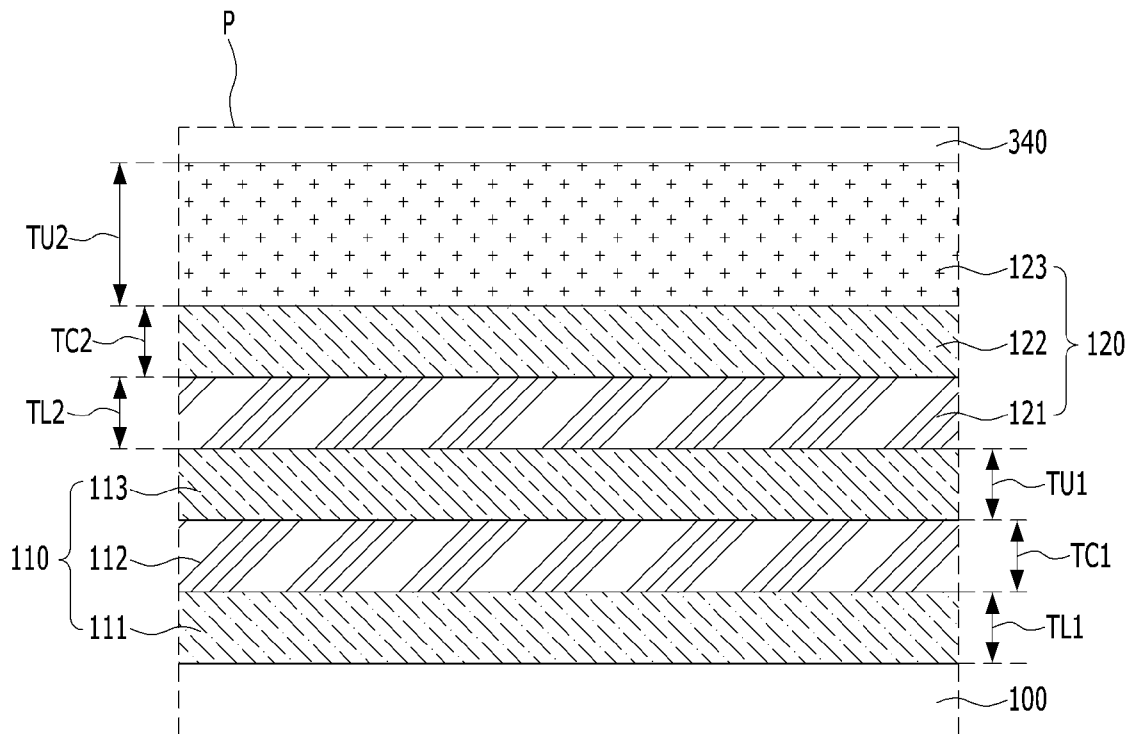

FIG. 3

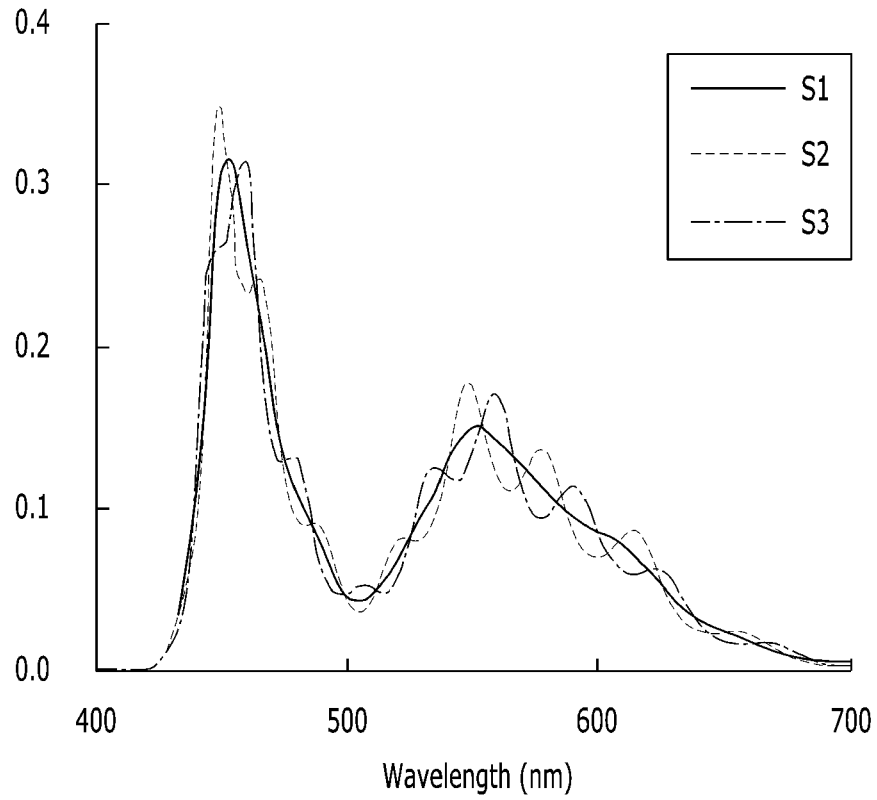

FIG. 4

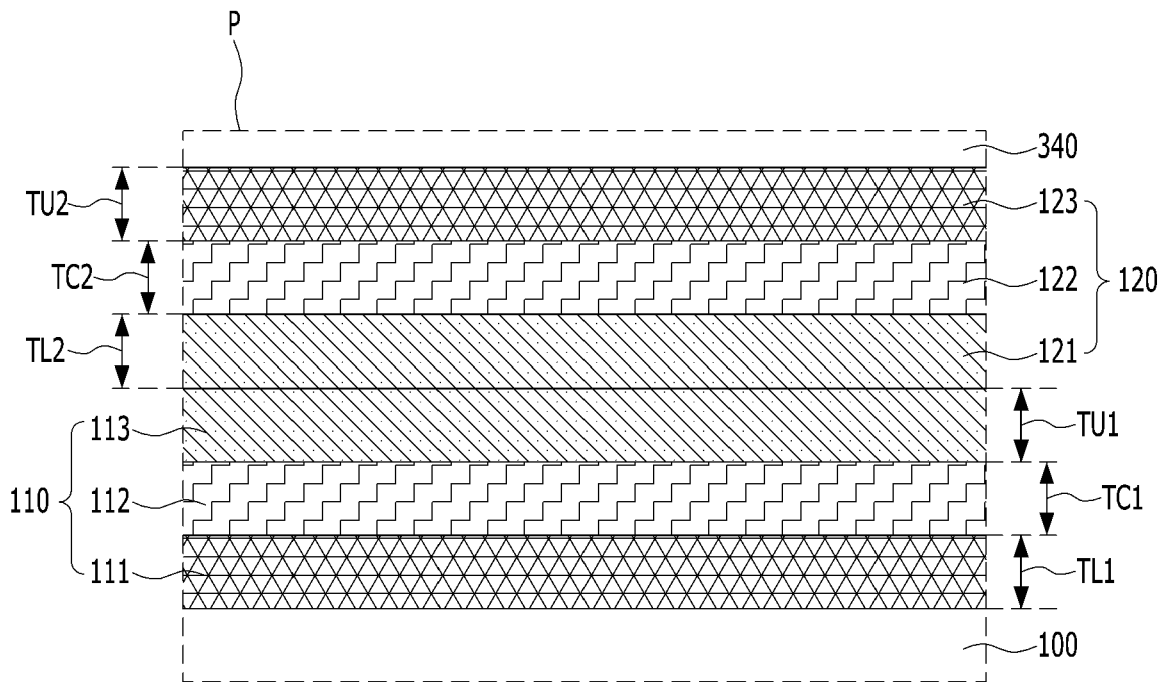

FIG. 5

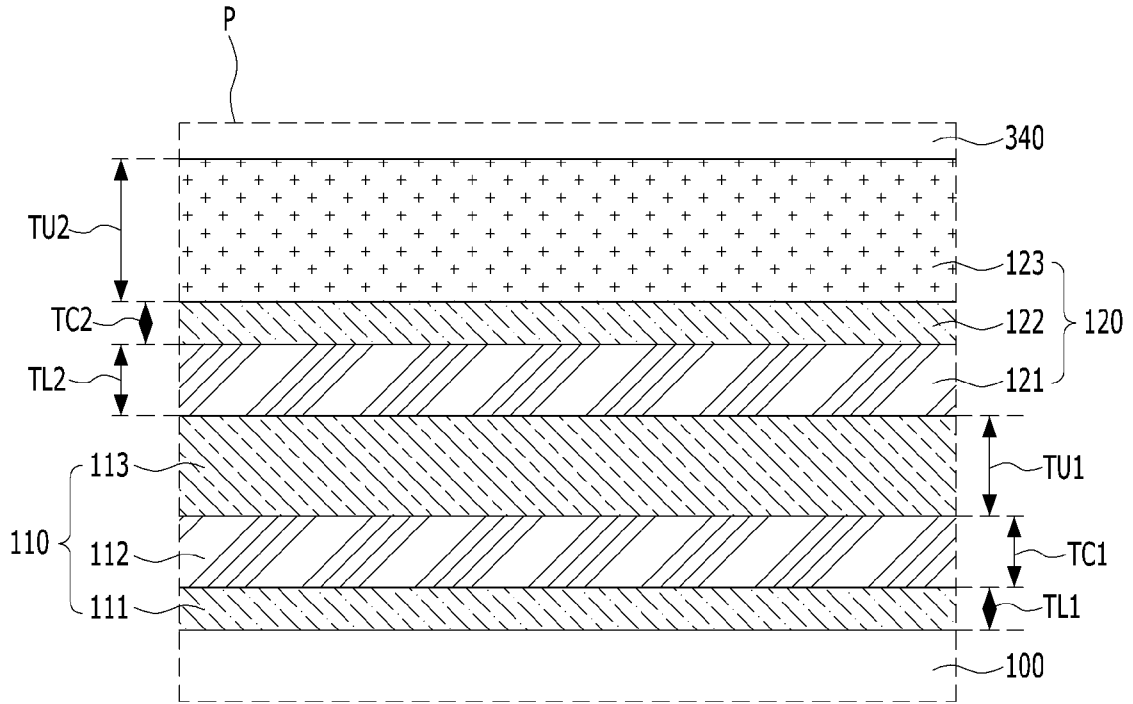

FIG. 6

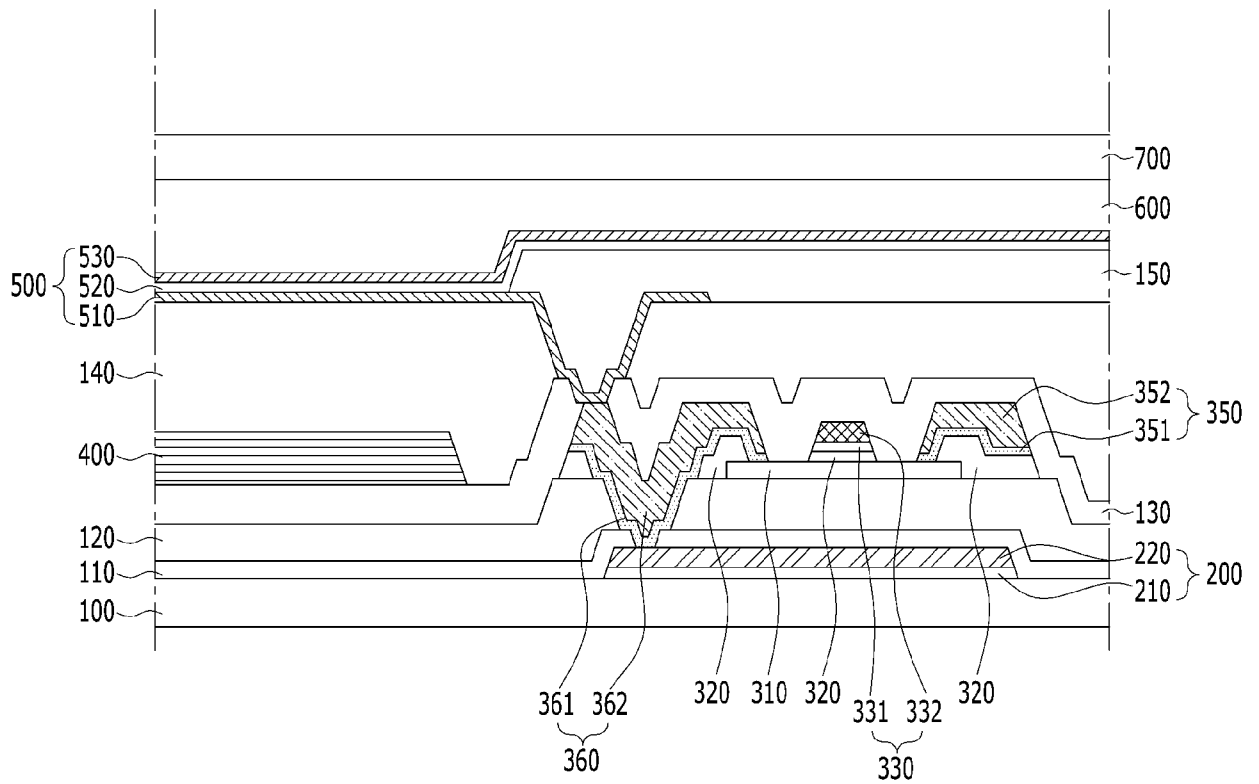

FIG. 7

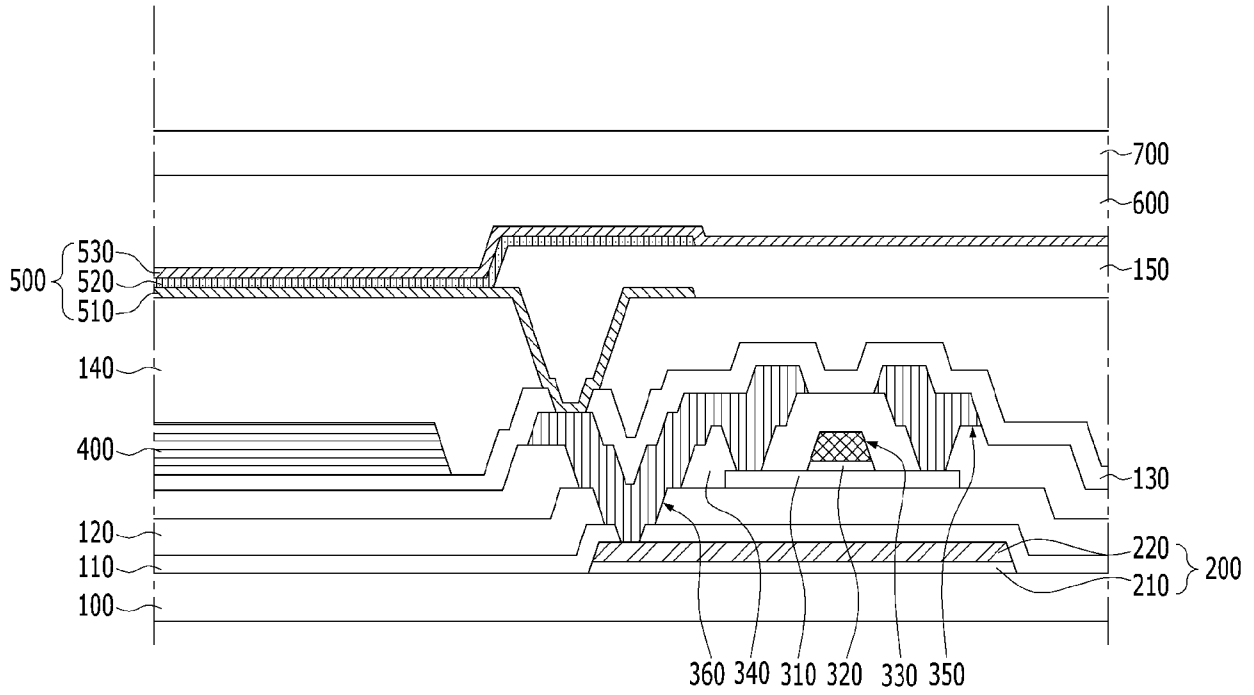

FIG. 8

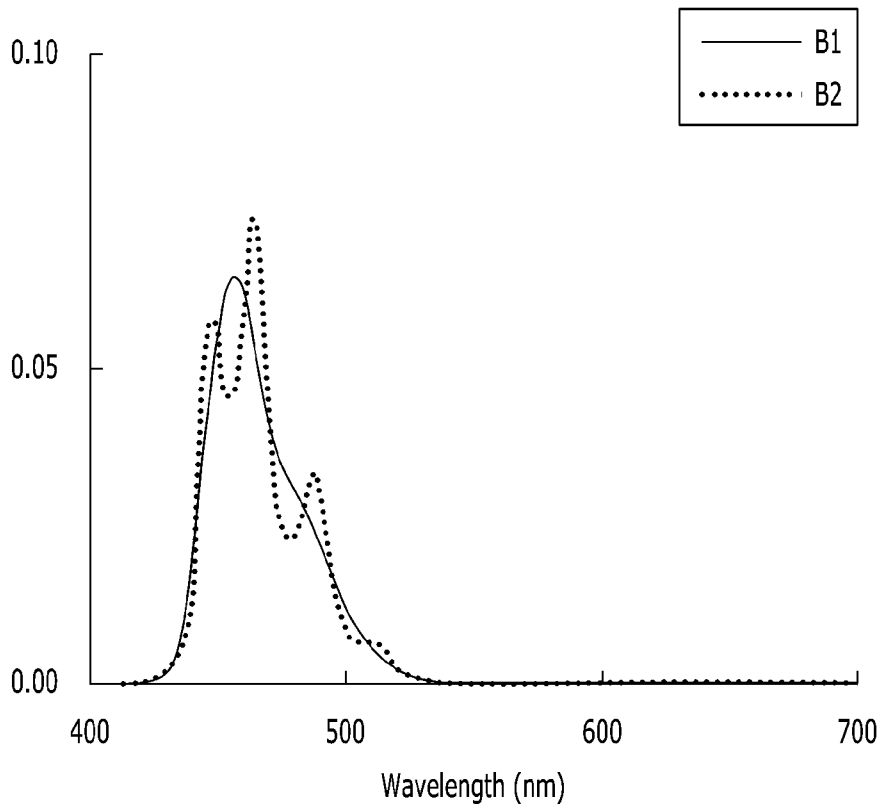

FIG. 9

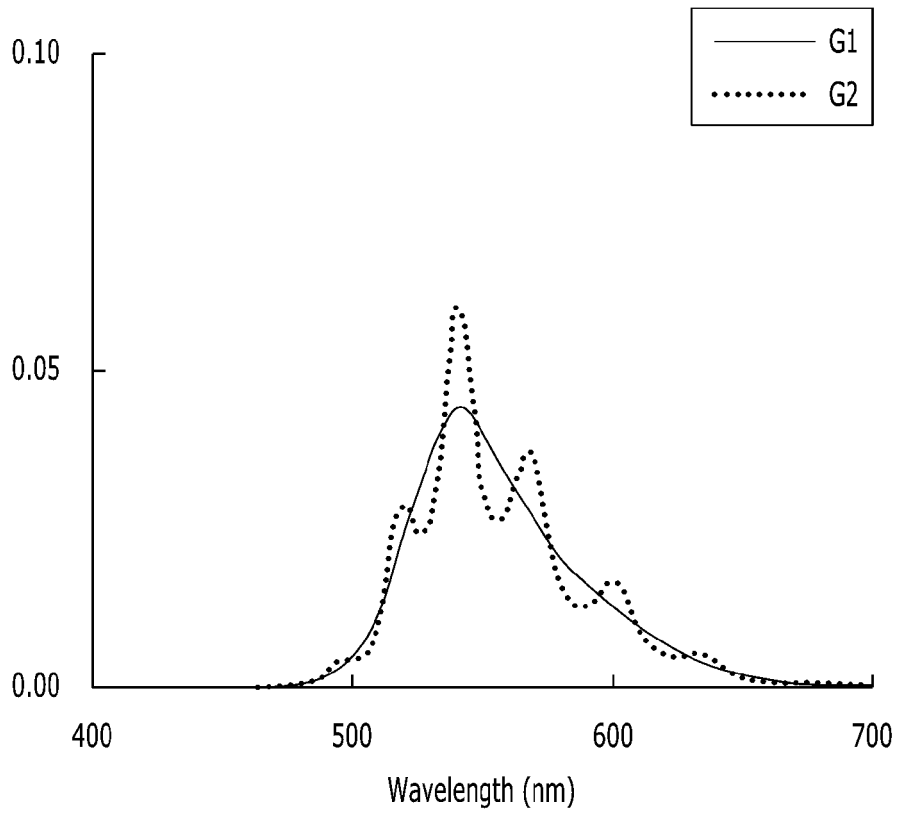
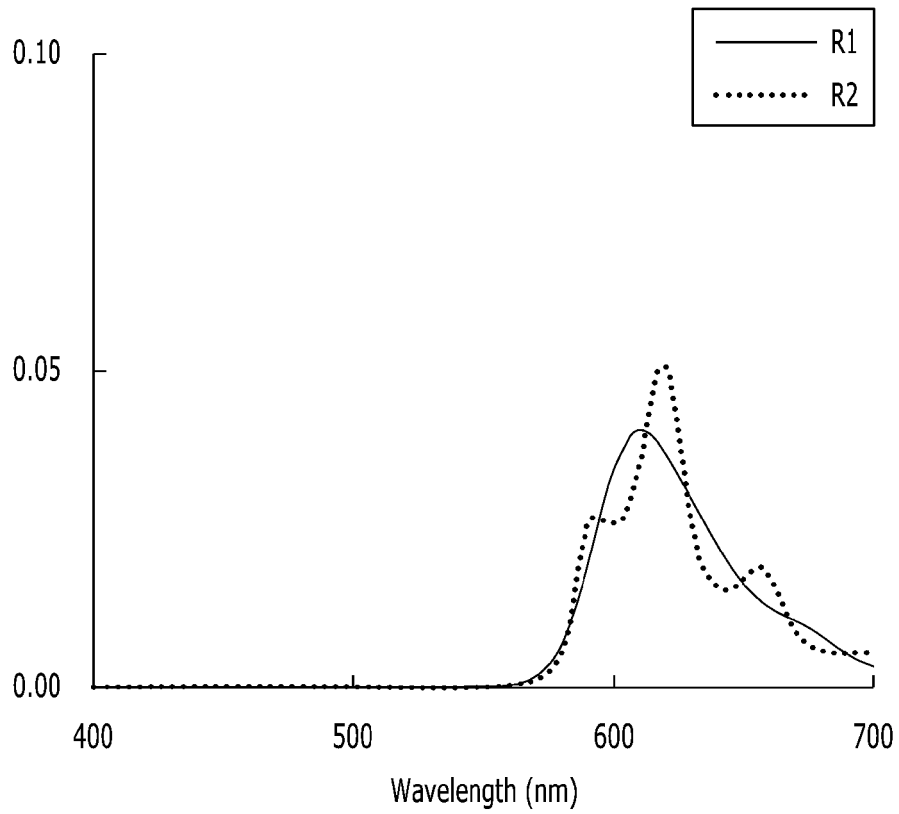

FIG. 10





EUROPEAN SEARCH REPORT

Application Number  
EP 19 20 1442

5

10

15

20

25

30

35

40

45

50

55

DOCUMENTS CONSIDERED TO BE RELEVANT			
Category	Citation of document with indication, where appropriate, of relevant passages	Relevant to claim	CLASSIFICATION OF THE APPLICATION (IPC)
X	EP 3 261 148 A1 (BOE TECHNOLOGY GROUP CO LTD [CN]) 27 December 2017 (2017-12-27) * paragraphs [0026] - [0028], [0051], [0054]; figure 1a *	1,13-15	INV. H01L27/32 H01L51/52
X	US 2012/097957 A1 (KIM SUNG-HO [KR]) 26 April 2012 (2012-04-26) * paragraph [0118]; figures 30,31 *	13,15	
A	US 2012/098008 A1 (SONG JUNG-BAE [KR] ET AL) 26 April 2012 (2012-04-26) * paragraphs [0042] - [0044], [0049]; figure 1 *	1-15	
			TECHNICAL FIELDS SEARCHED (IPC)
			H01L
The present search report has been drawn up for all claims			
Place of search The Hague		Date of completion of the search 20 February 2020	Examiner Faou, Marylène
CATEGORY OF CITED DOCUMENTS X : particularly relevant if taken alone Y : particularly relevant if combined with another document of the same category A : technological background O : non-written disclosure P : intermediate document		T : theory or principle underlying the invention E : earlier patent document, but published on, or after the filing date D : document cited in the application L : document cited for other reasons & : member of the same patent family, corresponding document	

1  
EPO FORM 1503 03/02 (P04C01)

ANNEX TO THE EUROPEAN SEARCH REPORT  
ON EUROPEAN PATENT APPLICATION NO.

EP 19 20 1442

5

This annex lists the patent family members relating to the patent documents cited in the above-mentioned European search report. The members are as contained in the European Patent Office EDP file on  
The European Patent Office is in no way liable for these particulars which are merely given for the purpose of information.

20-02-2020

10

Patent document cited in search report	Publication date	Patent family member(s)	Publication date
EP 3261148 A1	27-12-2017	CN 104576706 A EP 3261148 A1 WO 2016119378 A1	29-04-2015 27-12-2017 04-08-2016
US 2012097957 A1	26-04-2012	CN 102456843 A KR 20120042143 A US 2012097957 A1	16-05-2012 03-05-2012 26-04-2012
US 2012098008 A1	26-04-2012	KR 20120042037 A US 2012098008 A1	03-05-2012 26-04-2012

15

20

25

30

35

40

45

50

55

EPO FORM P0459

For more details about this annex : see Official Journal of the European Patent Office, No. 12/82

**REFERENCES CITED IN THE DESCRIPTION**

*This list of references cited by the applicant is for the reader's convenience only. It does not form part of the European patent document. Even though great care has been taken in compiling the references, errors or omissions cannot be excluded and the EPO disclaims all liability in this regard.*

**Patent documents cited in the description**

- KR 1020180123316 [0001]

专利名称(译)	显示装置及发光装置		
公开(公告)号	<a href="#">EP3640992A1</a>	公开(公告)日	2020-04-22
申请号	EP2019201442	申请日	2019-10-04
[标]申请(专利权)人(译)	乐金显示有限公司		
申请(专利权)人(译)	LG DISPLAY CO. , LTD.		
当前申请(专利权)人(译)	LG DISPLAY CO. , LTD.		
[标]发明人	LIM JUNG SHIK KIM SUN MAN LEE MIN GYU		
发明人	LIM, JUNG-SHIK KIM, SUN-MAN LEE, MIN-GYU		
IPC分类号	H01L27/32 H01L51/52		
CPC分类号	H01L27/156 H01L27/322 H01L27/3244 H01L33/44 H01L51/5275 H01L27/3258 H01L27/3272		
优先权	1020180123316 2018-10-16 KR		
外部链接	<a href="#">Espacenet</a>		

摘要(译)

提供一种具有发光装置 ( 500 ) 的显示装置。显示设备可以包括缓冲绝缘层, 该缓冲绝缘层设置在从发光装置 ( 500 ) 发射的光的路径上。缓冲绝缘层可以具有第一缓冲绝缘层 ( 110 ) 和第二缓冲绝缘层的堆叠结构, 所述第一缓冲绝缘层 ( 110 ) 的折射率在远离发光器件 ( 500 ) 的方向上减小。在远离发光器件 ( 500 ) 的方向上增加的折射率。因此, 在显示设备中, 可以防止从发光装置 ( 500 ) 发射的光的意外的相长和相消干涉。因此, 在显示装置中, 可以提高发光效率, 并且可以防止色坐标的变化。

FIG. 1

