

(19)



(11)

EP 2 359 357 B1

(12)

EUROPEAN PATENT SPECIFICATION

(45) Date of publication and mention of the grant of the patent:
21.01.2015 Bulletin 2015/04

(51) Int Cl.:
G09G 3/32^(2006.01)

(21) Application number: **09801841.9**

(86) International application number:
PCT/US2009/006594

(22) Date of filing: **16.12.2009**

(87) International publication number:
WO 2010/080113 (15.07.2010 Gazette 2010/28)

(54) DIGITAL-DRIVE ELECTROLUMINESCENT DISPLAY WITH AGING COMPENSATION

DIGITAL ANGESTEUERTE ELEKTROLUMINESZENZANZEIGE MIT ALTERUNGSKOMPENSATION

AFFICHAGE ÉLECTROLUMINESCENT À ACTIONNEMENT NUMÉRIQUE AVEC COMPENSATION DU VIEILLISSEMENT

(84) Designated Contracting States:
AT BE BG CH CY CZ DE DK EE ES FI FR GB GR HR HU IE IS IT LI LT LU LV MC MK MT NL NO PL PT RO SE SI SK SM TR

- **HAMER, John, W.**
Rochester
New York 14650 (US)
- **PARRETT, Gary**
Rochester
New York 14650 (US)
- **WHITE, Christopher, Jason**
Rochester
New York 14650 (US)

(30) Priority: **18.12.2008 US 337668**

(43) Date of publication of application:
24.08.2011 Bulletin 2011/34

(73) Proprietor: **Global OLED Technology LLC**
Herndon, VA 20171 (US)

(74) Representative: **Gunzelmann, Rainer et al**
Wuesthoff & Wuesthoff
Patent- und Rechtsanwälte
Schweigerstraße 2
81541 München (DE)

- (72) Inventors:
- **LEVEY, Charles, I.**
Rochester
New York 14650 (US)
 - **LEON, Felipe, Antonio**
Rochester
New York 14650 (US)

(56) References cited:
WO-A-2007/036837 KR-B1- 100 873 707
US-A1- 2003 071 821 US-A1- 2005 179 628
US-A1- 2006 170 623 US-A1- 2008 122 759
US-A1- 2008 252 568 US-B1- 7 355 574

EP 2 359 357 B1

Note: Within nine months of the publication of the mention of the grant of the European patent in the European Patent Bulletin, any person may give notice to the European Patent Office of opposition to that patent, in accordance with the Implementing Regulations. Notice of opposition shall not be deemed to have been filed until the opposition fee has been paid. (Art. 99(1) European Patent Convention).

Description**FIELD OF THE INVENTION**

5 **[0001]** The present invention relates to solid-state electroluminescent flat-panel displays and more particularly to such displays having ways to compensate for aging of the electroluminescent display components.

BACKGROUND OF THE INVENTION

10 **[0002]** Electroluminescent (EL) devices have been known for some years and have been recently used in commercial display devices. Such devices employ both active-matrix and passive-matrix control schemes and can employ a plurality of subpixels. In an active-matrix control scheme, each subpixel includes an EL emitter and a drive transistor for driving current through the EL emitter. The subpixels are typically arranged in two-dimensional arrays with a row and a column address for each subpixel, and having a data value associated with the subpixel. Subpixels of different colors, such as red, green, blue, and white are grouped to form pixels. Active-matrix EL displays can be made from various emitter technologies, including coatable-inorganic light-emitting diode, quantum-dot, and organic light-emitting diode (OLED), and various backplane technologies, including amorphous silicon (a-Si), zinc oxide, and low-temperature polysilicon (LTPS).

20 **[0003]** Some transistor technologies, such as LTPS, can produce drive transistors that have varying mobilities and threshold voltages across the surface of a display (Kuo, Yue, ed. Thin Film Transistors: Materials and Processes, vol. 2: Polycrystalline Thin Film Transistors. Boston: Kluwer Academic Publishers, 2004. pg. 410-412). This produces objectionable nonuniformity. These nonuniformities are present at the time the display is sold to an end user, and so are termed initial nonuniformities, or "mura." FIG. 8 shows an example histogram of subpixel luminance exhibiting differences in characteristics between subpixels. All subpixels were driven at the same level, so should have had the same luminance. 25 As FIG. 8 shows, the resulting luminances varied by 20 percent in either direction. This results in unacceptable display performance.

[0004] It is known to compensate for drive-transistor-related mura by employing a digital drive, or pulse-width modulated, display scheme. Unlike an analog drive display, in which the rows of the display are scanned sequentially once per frame period, a digital drive display scans the rows multiple times per frame. Each time a row is selected in a digital drive scheme, each subpixel in the row is either activated to output light at a selected level, or inactivated to emit no light. This is different from an analog drive display, in which each subpixel is caused to emit light at one of a plurality of levels corresponding to the available code values (e.g. 256).

30 **[0005]** For example, Ouchi et al., in U.S. Patent Nos. 6,724,377 and 6,885,385, teach dividing each frame into a plurality of smaller subframes. This subframe configuration is controlled by a plurality of shift registers that activate the rows of pixel circuits in a plurality of interleaved sequences for data writing.

[0006] Kawabe, in commonly-assigned U.S. Patent Application No. 2008/088561, teaches an improvement to the above method wherein a single shift register is used to track the multiple sequences for data writing, and a series of enable control lines are used to control which of the multiple sequences is written at a given time. This method uses a two-transistor, one-capacitor (2T1C) subpixel circuit.

40 **[0007]** However, transistor-related mura is not the only cause of nonuniformity in an EL display. For example, as an OLED display is used, organic light-emitting materials in the display age and become less efficient at emitting light. Aging of an OLED emitter causes a decrease in the efficiency of the emitter, the amount of light output per unit current, and an increase in the impedance of the emitter, and thus its voltage at a given current. Both effects reduce the lifetime of the display. The differing organic materials can age at different rates, causing differential color aging and a display whose white point varies as the display is used. In addition, each individual subpixel can age at a rate different from other subpixels, resulting in display nonuniformity. Furthermore, changes in the temperature of an OLED emitter can change its voltage at a given current.

[0008] It is known to combine OLED emitters with low-temperature polysilicon drive transistors. In this configuration, the increase in OLED voltage as the emitter ages reduces the voltage across the drive transistor, and thus the amount of current produced. This causes further display nonuniformity.

50 **[0009]** One technique to compensate for these aging effects is described by Mikami et al. in U.S. Patent Application Publication No. 2002/0140659. This technique teaches a comparator in each subpixel to compare a data voltage to a rising reference voltage, or a falling data voltage to a fixed reference voltage. A data voltage is thus converted to an on-time of the EL subpixel. However, this technique requires complimentary logic or resistors on the EL display, both of which are difficult to fabricate on modern displays. Furthermore, this technique does not recognize the problem of OLED voltage rise or efficiency loss.

55 **[0010]** Kimura, in U.S. Patent No. 7,138,967, describes using a current source and switch in every subpixel to drive uniform current during the on-time. This mitigates elevated black levels, a common problem with current-mode drive,

but requires a very complex subpixel circuit which can reduce the aperture ratio, the amount of light-emitting area available in the subpixel. This requires an increase in current density through the EL emitter to maintain a given luminance, accelerating the very aging for which the technique intends to compensate.

5 [0011] Yamashita, in U.S. Patent Application Publication No. 2006/0022305, describes a six-transistor, two-capacitor subpixel circuit driven in a scan phase, a light emission phase, and a reset phase during which the threshold voltage of the drive transistor and the turn-on voltage of the OLED are stored on capacitors connected to the data voltage terminal. This method does not compensate for OLED efficiency loss, and it requires a very complex subpixel having a very small aperture ratio. Such a subpixel ages more quickly and has lower manufacturing yields.

10 [0012] U.S. Patent Application Publication No. 2002/0167474 by Everitt describes a pulse width modulation driver for an OLED display. One embodiment of a video display includes a voltage driver for providing a selected voltage to drive an organic light-emitting diode in a video display. The voltage driver can receive voltage information from a correction table that accounts for aging, column resistance, row resistance, and other diode characteristics. In one embodiment of the invention, the correction tables are calculated prior to or during normal circuit operation. Since the OLED output light level is assumed to be linear with respect to OLED current, the correction scheme is based on sending a known current through the OLED diode for a duration sufficiently long to permit the transients to settle out, and then measuring the corresponding voltage with an analog-to-digital converter (A/D) residing on the column driver. A calibration current source and the A/D can be switched to any column through a switching matrix. However, this technique is only applicable to passive-matrix displays, not to the higher-performance active-matrix displays which are commonly employed. Further, this technique does not include any correction for changes in OLED emitters as they age, such as OLED efficiency loss.

15 [0013] Arnold et al., in U.S. Patent No. 6,995,519, teach a method of compensating for aging of an OLED device (emitter). This method relies on the drive transistor to drive current through the OLED emitter. However, drive transistors known in the art have non-idealities that are confounded with the OLED emitter aging in this method. Low-temperature polysilicon (LTPS) transistors can have nonuniform threshold voltages and mobilities across the surface of a display, and amorphous silicon (a-Si) transistors have a threshold voltage which changes with use. The method of Arnold et al. will therefore not provide complete compensation for OLED efficiency losses in circuits wherein transistors show such effects. Additionally, when methods such as reverse bias are used to mitigate a-Si transistor threshold voltage shifts, compensation of OLED efficiency loss can become unreliable without appropriate and expensive tracking and prediction of reverse bias effects.

20 [0014] Naugler et al., in U.S. Patent Application Publication No. 2008/0048951, teach measuring the current through an OLED emitter at various gate voltages of a drive transistor to locate a point on precalculated lookup tables used for compensation. However, this method requires a large number of lookup tables, consuming a significant amount of memory.

25 [0015] Document EP 2 026 319 A1 discloses an organic light emitting display, which includes: a sensing unit for extracting degradation information of an organic light emitting diode included in each of the pixels, and for transferring a first digital value and a second digital value corresponding to the extracted degradation information to a data driver; the data driver for generating data signals corresponding to second data supplied from a timing controller during a normal driving period; a first analog-digital converter for converting the voltage corresponding to the first digital value to a fourth digital value, and for converting the voltage corresponding to the second digital value to a fifth digital value; and the timing controller for storing the fourth digital value and the fifth digital value, and for changing first data supplied from an exterior in accordance with the fourth digital value and the fifth digital value to generate the second data.

30 [0016] Document US 2008/252 568 A1 discloses an organic light emitting display capable of displaying an image with uniform luminance regardless of deterioration of an organic light emitting diode and threshold voltage and/or mobility of a drive transistor. The organic light emitting display senses deterioration of the organic light emitting diode and threshold voltage and/or mobility of a drive transistor and modifies the data supplied to the pixel according to the sensed parameters.

35 [0017] Document US 2008/122 759 A1 discloses a method of compensating for changes in the threshold voltage of the drive transistor of an OLED drive circuit, comprising: providing the drive transistor with a first electrode, second electrode, and gate electrode; connecting a first voltage source to the first electrode, and an OLED device to the second electrode and to a second voltage source; providing a test voltage to the gate electrode of the drive transistor and connecting to the OLED drive circuit a test circuit that includes an adjustable current mirror that causes the voltage applied to the current mirror to be at a first test level; providing a test voltage to the gate electrode of the drive transistor and connecting the test circuit to the OLED device to produce a second test level after the drive transistor and the OLED device have aged; and using the first and second test levels to calculate a change in the voltage applied to the gate electrode of the drive transistor to compensate for aging of the drive transistor.

40 [0018] Document US 2005/179 628 A1 discloses a light emitting device and method for driving the device, in which the influence of fluctuations in the characteristics among transistors is removed, so as to obtain clear multi-gray scale. A light emitting device and a method for driving the device are also provided, in which an age-dependent change in amount of current flowing between two electrodes of a light emitting element is reduced, so as to obtain a clear multi-gray scale display.

[0019] Document US 2006/170 623 A1 discloses techniques for emissive pixels of flat panel displays. Specifically, pixel feedback and a combination of voltage modulation and pulse width modulation are used to improve the quality and consistency of aging pixels. Based on feedback, an image frame is divided into sub-frames of various time periods. Also based on feedback, a voltage, or voltages of different voltage levels, is (are) applied to the selected sub-frames to generate an image frame of a particular gray level. The human eye integrates the effects of the voltage and pulse width modulation techniques that are applied to the various sub-frames of the image frame, over the duration of the image frame.

[0020] There is a need, therefore, for a more complete compensation approach for electroluminescent displays.

SUMMARY OF THE INVENTION

[0021] It is therefore an object of the present invention to compensate for efficiency changes in OLED emitters in a digitally-driven electroluminescent display. This is achieved by a method of compensating for variations in characteristics of an electroluminescent (EL) emitter in an EL subpixel, in accordance with claim 1.

[0022] An advantage of this invention is an electroluminescent display, such as an OLED display, that compensates for the aging of the organic materials in the display wherein circuitry or transistor aging or nonuniformities are present, without requiring extensive or complex circuitry for accumulating a continuous measurement of subpixel use or time of operation. It is a further advantage of this invention that such compensation can be performed in displays driven by pulse-width, time-modulated signals to effect desired intensity levels at each subpixel. It is a further advantage of this invention that it uses simple voltage measurement circuitry. It is a further advantage of this invention that by making all measurements of voltage, it is more sensitive to changes than methods that measure current. It is a further advantage of this invention that a single select line can be used to enable data input and data readout. It is a further advantage of this invention that characterization and compensation of OLED changes are unique to the specific element and are not impacted by other elements that can be open-circuited or short-circuited. It is a further advantage of this invention that changes in the voltage measurements obtained over time can be separated into aging and temperature effects, enabling an accurate compensation for both.

BRIEF DESCRIPTION OF THE DRAWINGS

[0023]

FIG. 1 is a graph showing a representative relationship between OLED efficiency and OLED voltage change for a given OLED drive current

FIG. 2 is a graph showing a representative relationship between temperature and OLED voltage for a given OLED drive current density;

FIG. 3 is a schematic diagram of one embodiment of an electroluminescent (EL) display that can be used in the practice of the present invention;

FIG. 4 is a schematic diagram of one embodiment of an EL subpixel and connected components that can be used in the practice of the present invention;

FIG. 5 is a timing diagram of a digital-drive scheme according to the prior art;

FIG. 6 is a representative load-line diagram showing the effect of aging of an OLED emitter on OLED current;

FIG. 7A is a block diagram of an embodiment of the method of the present invention;

FIG. 7B is a block diagram of an embodiment of the method of the present invention; and

FIG. 8 is a histogram of luminances of subpixels exhibiting differences in characteristics.

DETAILED DESCRIPTION OF THE INVENTION

[0024] Characteristics of an EL emitter include its efficiency, typically expressed in cd/A or as a percentage of a reference cd/A value, and its resistance, which relates to the voltage across the emitter for a given current. Referring to FIG. 1, there is shown a representative relationship between efficiency and ΔV_{OLED} for an OLED emitter. In this figure, variations in the characteristics of the EL emitter, e.g. efficiency, are caused by aging of the EL emitter, measured by ΔV_{OLED} . The relationship has been experimentally determined to be approximately independent of fade current density. By measuring the luminance decrease and its relationship to ΔV_{OLED} with a given current, a change in corrected signal necessary to cause an EL emitter to output a nominal luminance can be determined. This measurement can be done on a model system and thereafter stored in a lookup table or used as an algorithm.

[0025] Turning now to FIG. 2, there is shown an example of the relationship between OLED emitter temperature and the OLED voltage measured at a given current density. In this figure, variations in characteristics of the EL emitter, e.g. resistance and thus voltage, are caused by variations in the temperature of the EL emitter.

[0026] FIG. 1 and FIG. 2 show two factors known to impact the OLED voltage: aging and temperature. In order to

effect an accurate compensation for the effects of aging, it is necessary to differentiate between the change in OLED voltage caused by the aging process, and that caused by changes in the temperature. Note that OLED emitter temperature is affected by ambient temperature around the display and by heat generated on the display itself.

5 **[0027]** Turning now to FIG. 3, there is shown a schematic diagram of one embodiment of an electroluminescent (EL) display that can be used in the practice of the present invention. EL display 10 includes an array of a plurality of EL subpixels 60 arranged in rows and columns. EL display 10 includes a plurality of row select lines 20 wherein each row of EL subpixels 60 has a row select line 20. EL display 10 includes a plurality of readout lines 30 wherein each column of EL subpixels 60 has a readout line 30. Each readout line 30 is connected to a third switch 130, which selectively connects readout line 30 to a current source 160 during the calibration process. By connected, it is meant that the elements are directly connected or connected via another component, e.g. a switch, a diode, or another transistor. Although not shown for clarity of illustration, each column of EL subpixels 60 also has a data line, described further below. The plurality of readout lines 30 is connected to one or more multiplexers 40, which permits parallel/sequential readout of signals from EL subpixels, as will become apparent. Multiplexer 40 can be a part of the same structure as EL display 10, or can be a separate construction that can be connected to or disconnected from EL display 10. Note that "row" and "column" do not imply any particular orientation of the display. Readout lines 30 are connected through third switch 130 to current source 160, as will be described below.

10 **[0028]** In a preferred embodiment, the EL display 10 includes one or more temperature sensors 65 to permit measurement of the display or ambient temperature. Alternatively, the temperature sensor can be a discrete component on the driving electronics and accessed by a processing unit or integrated into a component of the driving electronics as is typical in the trade (analog-to-digital converters, microprocessors, application specific integrated circuits, etc.). Measurements of temperature can be performed and recorded during readout of signals from EL emitters in order to ascertain the impact of temperature on OLED voltage. For the description that follows, it is assumed that with this capability, we are able to then measure a signal as described, namely OLED voltage, and observe changes caused only by the aging process of the EL emitter.

15 **[0029]** Turning now to FIG. 4, there is shown a schematic diagram of one embodiment of an EL subpixel that can be used in the practice of the present invention. EL subpixel 60 includes an EL emitter 50, a drive transistor 70, a capacitor 75, a readout transistor 80, and a select transistor 90. Each of the transistors has a first electrode, a second electrode, and a gate electrode. A first voltage source 140 is selectively connected to the first electrode of drive transistor 70 by a first switch 110, which can be located on the EL display substrate or on a separate structure. The second electrode of drive transistor 70 is connected to EL emitter 50, and a second voltage source 150 can be selectively connected to EL emitter 50 by a second switch 120, which can also be off the EL display substrate. The EL emitter 50 can also be connected directly to the second voltage source 150. At least one first switch 110 and second switch 120 are provided for the EL display. Additional first and second switches can be provided if the EL display has multiple powered sub-groupings of pixels. The drive transistor 70 can be used as the first switch 110 by operating it in reverse bias so that substantially no current flows. Methods for operating transistors in reverse bias are known in the art. In normal display mode, the first and second switches are closed, and third and fourth switches described below are open. The gate electrode of drive transistor 70 is connected to the second electrode of select transistor 90 to selectively provide data from data line 35 to drive transistor 70 as is well known in the art. The first electrode of select transistor 90 is connected to a data line 35. Each of the plurality of row select lines 20 is connected to the gate electrodes of the select transistors 90 in the corresponding row of EL subpixels 60. The gate electrode of select transistor 90 is connected to the gate electrode of readout transistor 80.

20 **[0030]** The first electrode of readout transistor 80 is connected to the second electrode of drive transistor 70 and to EL emitter 50. Each of the plurality of readout lines 30 is connected to the second electrodes of the readout transistors 80 in the corresponding column of EL subpixels 60. Readout line 30 is connected to third switch 130. A respective third switch 130 (S3) is provided for each column of EL subpixels 60. The third switch permits current source 160 to be selectively connected to the second electrode of readout transistor 80. Current source 160, when connected by the third switch, provides a selected test current to EL emitter 50, causing constant current flow through the EL emitter. Third switch 130 and current source 160 can be provided located on or off the EL display substrate. The current source 160 can be used as the third switch 130 by setting it to a high-impedance (Hi-Z) mode so that substantially no current flows. Methods for setting current sources to high-impedance modes are known in the art.

25 **[0031]** The second electrode of readout transistor 80 is also connected to a voltage measurement circuit 170, which measures voltages to provide signals representative of characteristics of EL subpixel 60. Voltage measurement circuit 170 includes an analog-to-digital converter 185 for converting voltage measurements into digital signals, and a processor 190. The signal from analog-to-digital converter 185 is sent to processor 190. Voltage measurement circuit 170 can also include a memory 195 for storing voltage measurements, and a low-pass filter 180. Voltage measurement circuit 170 is connected through a multiplexer output line 45 and multiplexer 40 to a plurality of readout lines 30 and readout transistors 80 for sequentially reading out the voltages from a plurality of EL subpixels 60. If there are a plurality of multiplexers 40, each can have its own multiplexer output line 45. Thus, a plurality of EL subpixels can be driven simultaneously. The

plurality of multiplexers permits parallel reading out of the voltages from the various multiplexers 40, and each multiplexer permits sequential reading out of the readout lines 30 attached to it. This will be referred to herein as a parallel/sequential process.

[0032] Processor 190 can also be connected to data line 35 and select line 20 by way of a control line 95 and a driver circuit 155. Thus, processor 190 can provide predetermined data values to data line 35, and thus to the gate electrode of drive transistor 70, during the measurement process to be described herein. Processor 190 can also accept display data via input signal 85 and provide compensation for changes as will be described herein, thus providing compensated data to data line 35 using driver circuit 155 during the display process. Driver circuit 155 is a pulse-width modulated driver circuit which can include a gate driver connected to the row select lines 20, and a source driver connected to the data lines 35, as known in the art. This permits driver circuit 155, through the source driver, to provide selected test and drive voltages through select transistor 90 to the gate electrode of drive transistor 70.

[0033] As an EL emitter 50, e.g. an OLED emitter, is used, its efficiency can decrease and its resistance can increase. Both of these effects can cause the amount of light emitted by an EL emitter to decrease over time. The amount of such decrease will depend upon the use of the EL emitter. Therefore, the decrease can be different for different EL emitters in a display, which effect is herein termed spatial variations in characteristics of EL emitters 50. Such spatial variations can include differences in brightness and color balance in different parts of the display, and image "burn-in" wherein an off-displayed image (e.g. a network logo) can cause a ghost of itself to always show on the active display. It is desirable to compensate for such effects to prevent spatial variations from becoming objectionable to a viewer of the EL display.

[0034] Turning now to FIG. 5, there is shown a graphical view of an embodiment of a digital drive scanning sequence according to the prior art. A horizontal axis 410 shows time, and a vertical axis 430 shows horizontal scanning lines. FIG. 5 gives an example of four-bit (sixteen code value) digital driving for ease of description.

[0035] In this example, one cycle or frame period 420 contains a plurality of different subframes 440, 450, 460, and 470, wherein each subframe has a respective duration which is different from the duration of at least one other subframe. The durations are weighted so as to correspond to code values representing display element brightness. That is, the durations of N subframes within a cycle have ratios of 1 : 2 : 4 : 8 : ... : 2N. The durations in this example are therefore controlled so as to give, approximately,

duration 440 : duration 450 : duration 460 : duration 470 = 1 : 2 : 4 : 8. (Note that FIG. 5 is not to scale.) When an code value bit is "1," a selected drive voltage is provided to the gate of the drive transistor 70, causing the EL subpixel 60 to be activated or illuminated for the corresponding subframe, which is herein called an activated subframe. When an intensity bit is "0," a selected black voltage is provided to the gate of the drive transistor 70, to cause the EL subpixel 60 to be deactivated or extinguished for the corresponding subframe, which is herein called a deactivated subframe. The on-time is defined as the sum of the durations of activated subframes for a given EL subpixel circuit 60 and its EL emitter 50, and corresponds to the desired brightness of the display element of such circuit. A four-bit (16-code value) display is thus possible by performing control in this manner. It is also possible, with additional subframes, to apply this to cases of greater brightness resolution using six bits or eight bits. In a preferred embodiment, the selected drive voltage causes the drive transistor to operate in the linear region during the on-time, and the selected black voltage causes the drive transistor to produce a current (e.g. <10nA) which does not produce visible light from the EL emitter (e.g. <0.1 nit emission).

[0036] Turning now to FIG. 7A, and referring also to FIG. 4, there is shown a block diagram of one embodiment of the method of the present invention.

[0037] To measure the characteristics of an EL emitter 50, first switch 110, and fourth switch 131, if present, are opened, and second switch 120 and third switch 130 are closed (Step 340). Select line 20 is made active for a selected row to turn on readout transistor 80 (Step 345). A selected test current, I_{testsu} , thus flows from current source 160 through EL emitter 50 to second voltage source 150. The value of current through current source 160 is selected to be less than the maximum current possible through EL emitter 50; a typical value will be in the range of 1 to 5 microamps and will be constant for all measurements during the lifetime of the EL subpixel. More than one measurement value can be used in this process, e.g. measurement can be performed at 1, 2, and 3 microamps. Taking measurements at more than one measurement value permits forming a complete I-V curve of the EL subpixel 60. Voltage measurement circuit 170 is used to measure the voltage on readout line 30 (Step 350). This voltage is the voltage V_{out} at the second electrode of readout transistor 80 and can be used to provide a first emitter-voltage signal V_2 that is representative of characteristics of EL emitter 50, including the resistance and efficiency of EL emitter 50.

[0038] The voltages of the components in the subpixel are related by:

$$V_2 = CV + V_{\text{OLED}} + V_{\text{read}} \quad (\text{Eq. 1})$$

The values of these voltages will cause the voltage at the second electrode of readout transistor 80 (V_{out}) to adjust to

fulfill Eq. 1. Under the conditions described above, CV is a set value and V_{read} can be assumed to be constant as the current through the readout transistor is low and does not vary significantly over time. V_{OLED} will be controlled by the value of current set by current source 160 and the current-voltage characteristics of EL emitter 50.

[0039] V_{OLED} can change with age-related changes in EL emitter 50. To determine the change in V_{OLED} , two separate test measurements are performed at different times. The first measurement is performed at a first time, e.g. when EL emitter 50 is not degraded by aging. This can be any time before EL subpixel 60 is used for display purposes. The value of the voltage V_2 for the first measurement is the first emitter-voltage signal (hereinafter V_{2a}), and is measured and stored. At a second time different from the first time, e.g. after EL emitter 50 has aged by displaying images for a predetermined time, the measurement is repeated. The resulting measured V_2 is a second emitter-voltage signal (hereinafter V_{2b}), and is stored.

[0040] If there are additional EL subpixels in the row to be measured, multiplexer 40 connected to a plurality of readout lines 30 is used to permit voltage measurement circuit 170 to sequentially measure each of a plurality of EL subpixels, e.g. every subpixel in the row (decision step 355), and provide a corresponding first and second emitter-voltage signal for each subpixel. Each of the plurality of EL subpixels can be driven simultaneously to advantageously reduce the time required for measurement by permitting all EL subpixels to settle simultaneously rather than sequentially. If the display is sufficiently large, it can require a plurality of multiplexers wherein the first and second emitter-voltage signals are provided in a parallel/sequential process. If there are additional rows of subpixels to be measured in EL display 10, Steps 345 to 355 are repeated for each row (decision step 360). To advantageously accelerate the measurement process, the EL emitter in each of the plurality of EL subpixels, e.g. each EL subpixel in the row, can be provided with the selected test current simultaneously so that any settling time will have elapsed when the measurement is taken. This prevents having to wait for each subpixel to settle individually before taking a measurement.

[0041] Changes in EL emitter 50 can cause changes to V_{OLED} to maintain the test current I_{testsu} . These V_{OLED} changes will be reflected in changes to V_2 . The first and second stored emitter-voltage signals (V_{2a} and V_{2b}) for each EL subpixel 60 can therefore be compared to calculate an aging signal ΔV_2 representative of the characteristics, e.g. efficiency and resistance, of the EL emitter 50 (Step 370) as follows:

$$\Delta V_2 = V_{2b} - V_{2a} = \Delta V_{OLED} \quad (\text{Eq. 2})$$

The aging signal for the EL subpixel 60 can then be used to compensate for changes in characteristics of that EL subpixel.

[0042] Referring to FIG. 6, in a p-channel non-inverted configuration wherein the drive transistor is operated in the linear region, V_{OLED} changes cannot be compensated with V_{OLED} measurements alone, as V_{OLED} changes modulate V_{ds} of the drive transistor, affecting the whole system. Complete compensation can be provided by calculating a drive transistor load line, which is a V_{ds} - I_{ds} curve, and comparing it with an EL emitter V_{OLED} - I_{OLED} curve. FIG. 6 shows V_{ds} on the abscissa and drain current I_{ds} on the ordinate. I_{OLED} equals I_{ds} , and V_{OLED} equals the voltage of the first voltage supply 140 minus the voltage of the second voltage 120 minus V_{ds} , permitting the transistor and EL emitter curves to be superimposed. A drive transistor load line 601 can be determined by transistor characterization and stored in a nonvolatile memory when a display is manufactured, or it can be measured for each drive transistor.

[0043] As shown on FIG. 6, an aged current 693 is at the intersection of an aged OLED load line 603 and drive transistor load line 601. One advantage of operating in the linear region is indicated by equal voltage intervals 680a and 680b. In the linear region, voltage interval 680a corresponds to current interval 681 a. In the saturation region, the same voltage shift (680b) corresponds to much smaller current interval 681b. Therefore, operating in the linear region advantageously improves signal-to-noise ratio. Another advantage of operating in the linear region is that the behavior of the transistor can be approximated by a straight line (640) without incurring unacceptable error.

[0044] Referring to FIG. 4, to measure a drive transistor load line, a current sink 165 is used. A fourth switch 131 is provided for selectively connecting the current sink 115 to the second electrode of the readout transistor. The current sink 165 can be used as the fourth switch 131 by setting it to a high-impedance (Hi-Z) mode so that substantially no current flows. A selected test voltage is provided by driver circuit 155 to the gate electrode of the drive transistor. The test voltage is preferably equal to the selected drive voltage used in normal operation of the display.

[0045] Turning now to FIG. 7B, there is shown a block diagram of load line measurements according to the present invention. The test voltage (V_{data}) is provided to data line 35 (Step 310). The first and fourth switches are closed and the second and third switches are opened (Step 315). Select line 20 is made active for a selected row to provide the test voltage to the gate electrode of drive transistor 70 and to turn on readout transistor 80 (Step 320). A selected first current $I_{sk,1}$ is provided by the current sink (Step 322) and thus flows from first voltage source 140 through the first and second electrode of drive transistor 70 and readout transistor 80 to current sink 165. The first current is selected to be less than the resulting current through drive transistor 70 due to the application of the test voltage; a typical value is from 1 to 5 microamps. Thus, the limiting value of current through drive transistor 70 will be controlled entirely by current sink

165, which will be the same as through drive transistor 70. The test voltage and first current can be selected based upon known or determined current-voltage and aging characteristics of drive transistor 70. Voltage measurement circuit 170 is used to measure the voltage on readout line 30, which is the voltage V_{out} at the second electrode of readout transistor 80, providing a first transistor-voltage signal V_{1T} that is representative of characteristics of drive transistor 70 (Step 325).
 5 The voltage at the second electrode of readout transistor 80 (V_{out}) will adjust to fall on the point on the drive transistor load line corresponding to $I_{sk,1}$.

[0046] If the EL display incorporates a plurality of subpixels and there are additional EL subpixels in the row to be measured, multiplexer 40 connected to a plurality of readout lines 30 can be used to permit voltage measurement circuit 170 to sequentially read out the first signals V_{1T} from a plurality of EL subpixels, e.g. every subpixel in the row (decision step 330). If the display is sufficiently large, it can require a plurality of multiplexers wherein the first signal can be provided in a parallel/sequential process. If there are additional rows of subpixels to be measured (Step 335), a different row is selected by a different select line and the measurements are repeated. Multiple subpixels can be driven simultaneously with the test current, as described above in the context of EL emitter measurements.

[0047] To determine the drive transistor load line, two separate test measurements are performed of each subpixel. After the first measurement is taken of all the subpixels in the row (decision step 332), a second current $I_{sk,2}$ not equal to the first current $I_{sk,1}$ is selected (step 322) and a second measurement of the voltage at the second electrode of the readout transistor is taken to provide a second transistor-voltage signal V_{2T} for each subpixel in the row. V_{2T} also falls on the drive transistor load line. Referring to FIG. 6, in the linear region of operation, the drive transistor load line 601 is approximately a straight line, and so can be characterized by two points. The offset and slope of a linear fit 640 of the linear region of the drive transistor load line 601 are thus calculated as known in the mathematical art from the two points ($V_{1T}, I_{sk,1}$) 610 and ($V_{2T}, I_{sk,2}$) 611. First current $I_{sk,1}$ is shown as 690; second current $I_{sk,2}$ is shown as 691.

[0048] The two measurements of each subpixel can be taken in either order, and the first measurement for all subpixels on all rows of the display can be taken before the second measurement of any subpixel. The first current can be higher or lower than the second current, so point 610 can be above point 611 instead of below it.

[0049] EL emitter voltage can be affected by both aging effects and temperature. Measurements obtained must be adjusted for temperature variations from measurement to measurement in order to effectively compensate for both current loss and efficiency loss. In a model system, a correlation between ambient temperature and OLED voltage can be obtained and stored as an equation or lookup table. An example of this relationship is shown in FIG. 2. This relationship represents the voltage of the EL emitter over a typical operating temperature range at the current I_{testsu} to be used for EL emitter characterization. The function, an example of which is given by a curve fit 2, will hereinafter be denoted $V_{byT}(T)$, as it provides a representative OLED voltage for each temperature T . The temperature in the manufacturing environment where the reference measurements are performed is likely to differ from that of the consumer environment, where subsequent measurements of the EL emitter are performed. By recording the temperature of the manufacturing environment, T_1 , and using the temperature sensor 65 (FIG. 3) to measure the temperature T_2 of the environment during measurement cycles, a voltage change caused by temperature can be computed using FIG. 2 and the following equation:

$$\Delta V_{oled_temp} = V_{byT}(T_2) - V_{byT}(T_1) \quad (\text{Eq. 3})$$

where ΔV_{oled_temp} is the OLED voltage change caused by variations in ambient temperature, and $V_{oled}(T_1)$ and $V_{oled}(T_2)$ are the EL emitter voltages in the factory and consumer environments, respectively. First and second emitter-voltage measurements can then be adjusted according to temperature:

$$V_{2a'} = V_{2a} - \Delta V_{oled_temp} \quad (\text{Eq. 4a})$$

$$V_{2b'} = V_{2b} - \Delta V_{oled_temp} \quad (\text{Eq. 4b})$$

$V_{2a'}$ and $V_{2b'}$ can then be used in place of V_{2a} and V_{2b} wherever necessary. In a preferred embodiment, first emitter-voltage signal V_{2a} is measured in the factory at temperature T_1 , and only second emitter-voltage signal V_{2b} , measured at temperature T_2 , is adjusted for temperature.

[0050] Aging signal $\Delta V_2 (= \Delta V_{OLED})$ can also be adjusted for temperature:

$$\Delta V_2' = \Delta V_2 - \Delta V_{oled_temp} \quad (\text{Eq. 4c})$$

5 $\Delta V_2'$ can be used in place of ΔV_2 wherever necessary.

[0051] Turning to FIG. 6, there is shown a graphical illustration of the effect of EL emitter aging, and in this example of OLED aging. An unaged OLED load line 602 shows the I-V behavior of an OLED emitter before aging. Aged OLED load line 603 shows the I-V behavior of the same OLED emitter after aging. Aged line 603 is approximately a percentage of unaged line 602. A point 621 indicates the OLED voltage V_{2a} 631, the first emitter-voltage signal, at test current 692 (I_{testsu}) before aging; a point 622 indicates an OLED voltage V_{2b} 632, the second emitter-voltage signal, at test current 692 after aging. Note that the first emitter-voltage signal can be after aging and the second emitter-voltage signal before aging.

[0052] Unaged OLED load line 602 can be characterized or measured for each subpixel, a group containing a plurality of subpixels, or the whole display. The display can be divided into multiple spatial or color (e.g. red, green, blue or white) regions, each of which can have a different unaged OLED load line curve than at least one other region. Unaged OLED load line(s) 602 can be stored in nonvolatile memory with the display as equation coefficient(s) or in lookup table(s).

[0053] Aged OLED load line 603 is typically a percentage of unaged load line 602. Denoting unaged load line 602 as a function $O_New(V)$ mapping voltage to current, and aged load line 603 as an analogous function $O_Aged(V)$,

20

$$O_Aged(V) = \text{gamma} * O_New(V) \quad \text{for all } V. \quad (\text{Eq. 5})$$

25 The value of gamma can be computed using points 622 and 623. Point 622 is (V_{2b} , I_{testsu}). Point 623 is thus (V_{2b} , $O_New(V_{2b})$). Gamma is thus

$$\text{gamma} = I_{testsu} / O_New(V_{2b}) \quad (\text{Eq. 6})$$

30

Using gamma, any point on aged load line 603 can be calculated using Eq. 5.

[0054] In the embodiment of FIG. 7B, the drive transistor load line, and thus the first and second transistor-voltage signals and the first and second currents, can therefore be used in providing the aging signal to provide complete compensation. Referring back to FIG. 6, the operating point of the EL subpixel after aging is point 624, the intersection of the drive transistor 601 and aged OLED 603 load lines respectively. Once gamma has been determined per Eq. 6, the aged OLED load line 603 can be calculated according to Eq. 5. Standard mathematical techniques such as Newton's method can then be used to find the intersection of aged OLED load line 603 and drive transistor load line 601. To use Newton's method, point 621 or 622, or another point, can be used as the starting point.

[0055] In one embodiment, for simpler computation, a region of the unaged OLED load line 602 close to the typical operating voltage of the system can be selected, and a linear approximation made of that region. For example, the region between points 623 and 621 can be approximated with linear fit 641. This selection can be made at manufacturing time or while the display is operating. Linear fit 641 can then be multiplied by gamma to approximate the unaged OLED load line 603. Alternatively, a linear fit can be made of a region of the unaged OLED load line 603 after multiplication by gamma. For example, points 622 and 625 can define a region with linear fit 642. Once a linear fit for the aged OLED load line 603 has been selected, the intersection of that linear fit with linear fit 612 of the drive transistor load line 601 as known in the mathematical art. This is a one-step operation, as opposed to Newton's Method, which in general requires more than one iteration to converge to a solution.

[0056] The intersection point 624 between the aged OLED load line 603 and the drive transistor load line 601 can be expressed as ($V_{ds,aged}$, $I_{ds,aged}$). The original operating point, the intersection point 621 between the unaged OLED load line 602 and the drive transistor load line 601, can be expressed as ($V_{ds,new}$, $I_{ds,new}$). A normalized current can be calculated using these intersection points:

$$I_{norm} = I_{ds,aged} / I_{ds,new} \quad (\text{Eq. 7a})$$

55

I_{norm} can be the aging signal for the EL subpixel and represent characteristics of the EL emitter including resistance (forward voltage). $I_{ds,new}$ is shown in this example as equal to test current 692 and $I_{ds,aged}$ is shown as current 693. Note,

however, that test current $I_{\text{testsu}} 692$ and $I_{\text{ds,new}}$ are not required to be equal. The present invention does require any particular value of $I_{\text{testsu}} \cdot \Delta V_2$, computed in Eq. 2 above, can be the aging signal for the EL subpixel and represent characteristics of the EL emitter including efficiency, as will be described below.

[0057] To compensate for changes in EL emitter resistance (voltage), the normalized current is used, as shown above in Eq. 7a, in which I_{norm} represents the normalized current relative to its original current.

[0058] In a digital drive system where time is modulated to provide a predetermined integrated amount of current flow to an EL emitter 50, a decrease in current can be corrected by increasing the amount of on-time for the EL emitter. The reciprocal of I_{norm} is used as a scaling factor for the original on-time requested:

$$t_{I_comp} = \frac{1}{I_{\text{norm}}} \cdot t_{\text{data}} \quad (\text{Eq. 8})$$

where t_{I_comp} represents the on-time of EL emitter 50 to correct for the change in current flowing through it, and t_{data} is the on-time corresponding to a desired amount of light emission when the EL emitter was new. For example, if the aged current is found to be 0.5 (or 50%) of its original value, I_{norm} would be 0.5, and hence t_{I_comp} would be found to be 2 times the original on-time t_{data} .

[0059] To compensate for changes in EL emitter efficiency, EL emitter voltage change ΔV_2 is used. The EL emitter efficiency at any given time can be determined by understanding the relationship between ΔV_2 , adjusted for temperature if necessary so that it represents only changes caused by the aging process, and EL emitter efficiency. The relationship is denoted $E_{\text{byV}}(\Delta V)$. Normalized efficiency E_{norm} can thus be computed:

$$E_{\text{norm}} = E_{\text{byV}}(\Delta V_2). \quad (\text{Eq. 7b})$$

where ΔV_2 is as computed in Eq. 2.

[0060] FIG. 1 shows an example of this relationship for a given OLED device. For example, in FIG. 1, if an EL emitter 50 is found to have shifted by 0.3V in voltage from its new value ($\Delta V_2 = 0.3$), it can be inferred that it is emitting 77% the amount of light it emitted when it was new. The relationship between current and luminance is generally linear. In order to emit the same amount of light it did when it was new, the EL emitter 50 is provided the reciprocal of the normalized efficiency in on-time. EL emitter 50 is thus activated for e.g. $1/0.77 \approx 1.3$ times the amount of time it was before aging. Adjustment of the pulse-width modulated signal to obtain such increase in EL emitter 50 on-time can be performed by processor 190 using driver circuit 155. The following equation is used to calculate the compensated on-time:

$$t_{E_comp} = \frac{1}{E_{\text{norm}}} \cdot t_{\text{data}} \quad (\text{Eq. 9})$$

In this equation, t_{E_comp} represents the on-time of EL emitter 50 required to correct for the change in EL efficiency, E_{norm} is the efficiency of the aged EL emitter as computed in Eq. 7b, and t_{data} is the on-time corresponding to a desired amount of light emission when the EL emitter was new.

[0061] In the discussion above, the compensation for the loss in current and efficiency were discussed separately. In one embodiment of the present invention, the two compensations are combined to produce a single selected on-time. Note that it is shown here that the light output is returned to the original value, but this is not required. For example, when temperature shifts, the entire display can be permitted to shift, assuming that temperature will affect all EL emitters equally.

[0062] Referring back to Eq. 8, the first step in the compensation process is to drive the EL emitter in such a way that the integrated time and current are constant over time. Eq. 8 provides the method by which to compute the adjustment in the original amount of time the EL emitter would have been driven when it was new and flowing a full amount of current. Relative to efficiency compensation, Eq. 9 assumes that the EL emitter is driven fully, with a predetermined amount of integrated time and current. After aging has occurred and the time required to obtain such integrated time-current has changed as described in Eq. 8, Eq. 9 then becomes:

$$t_{full_comp} = \frac{1}{E_{norm}} \cdot t_{I_comp} \quad (\text{Eq. 10})$$

5 In Eq. 10, t_{full_comp} represents the amount of time required to fully compensate for the current and efficiency loss of the EL emitter, E_{norm} represent the normalized efficiency of the EL emitter, and t_{I_comp} represents the on-time required to compensate for the loss in EL emitter current. E_{norm} can be the aging signal for the EL subpixel, representing characteristics of the EL emitter, including the efficiency of the EL emitter. Returning to the example values used in the description above, the adjustment to the time signal required to fully compensate can be computed. Firstly, it was found that an adjustment of 2 times the amount of drive time was required to compensate due to the loss of current, assumed to be 50%. Hence $t_{I_comp} = 2 \cdot t_{data}$. The normalized efficiency was found to be 0.77, which was determined to require about a factor of 1.3 times the drive time, assuming full drive capability. The combination of these two time scaling factors using Eq. 10 then provides $t_{full_comp} = 2.6 \cdot t_{data}$. For full compensation, the aging signal for the EL emitter can include both I_{norm} and E_{norm} to represent the resistance and efficiency of the EL emitter. The aging signal can thus be 2.6, 1/2.6, or the tuples (0.5, 0.77) or (2, 1.3), or some combination..

10 **[0063]** During operation of the EL subpixel 60, an input signal is received (Step 375) which corresponds to the amount t_{data} of time during a given frame which the EL emitter is to be emitting light. The input signal can be a digital code value, a linear intensity, an analog voltage, or other forms known in the art. The aging signal and the input signal can then be used to calculate a selected on-time t_{full_comp} according to Eq. 10, above. The selected on-time can then be used to produce a corresponding compensated drive signal (Step 380).

15 **[0064]** For example, in a four bit digital-drive system with subframe duration ratios 8:4:2:1, the input signal I and compensated drive signal D are four-bit code values $b_3b_2b_1b_0$, where each b_x corresponds to the duration ratio 2^{x-1} (e.g. b_3 to 8). The input signal thus specifies t_{data} values from 0/15 of a frame ($I=0000_2$; the subscript is the base in which the number is expressed) to 15/15 (100%) of a frame ($I=1111_2$). The selected on-time t_{full_comp} calculated from t_{data} using Eq. 10 is rounded to the nearest multiple of 1/15 and multiplied by 15 to form the corresponding drive signal. For example, if $I=3_{10}$ (0001_2), $t_{data} = 3/15 = 0.2$. Using the examples above, $t_{full_comp} = 2.6 \cdot t_{data} = 0.52$. Rounded to the nearest multiple of 1/15 ($=0.067$), that becomes 8/15 = 0.533, so $D = 8_{10} = 1000_2$. Values of I for which $t_{full_comp} > 1.0$, e.g. 9₁₀ in this example ($t_{full_comp} = 1.56 \approx 23/15$) can be clipped to the maximum value of D (e.g. 1111₂). Other transformations from on-time to drive signal known in the digital-drive art can also be employed with the present invention. The compensated drive signal can be computed, e.g. by processor 190, using lookup tables, piecewise linear functions, or other techniques known in the art. Alternatively, t_{I_comp} or t_{E_comp} can be used as the selected on-time if compensation is only desired for one effect.

20 **[0065]** Using driver circuit 155, the selected drive voltage is provided (Step 385) to the gate electrode of the drive transistor for the selected on-time corresponding to compensated drive signal D . This selected on-time can be divided into a plurality of activated subframes, as described above. Activating the subpixel for the selected on-time compensates for variations in characteristics (e.g. voltage and efficiency) of the EL emitter according to the calculations given above.

25 **[0066]** When compensating an EL display having a plurality of EL subpixels, each subpixel is measured to provide a plurality of first and second emitter-voltage signals for respective subpixels, as described above. A respective aging signal for each subpixel is provided using the corresponding first and second emitter-voltage signals, also as described above. A corresponding input signal for each subpixel is received, and a corresponding compensated drive signal calculated as above using the corresponding aging signals. The compensated drive signal corresponding to each subpixel in the plurality of subpixels is provided to the gate electrode of that subpixel using driver circuit 155 as described above. This permits compensation for changes in characteristics of each EL emitter in the plurality of EL subpixels. In the embodiment of FIG. 7B, respective first and second transistor-voltage signals for each transistor can be measured and used in producing the corresponding aging signals for each of the plurality of EL subpixels.

30 **[0067]** In a preferred embodiment, the invention is employed in a display that includes Organic Light Emitting Diodes (OLEDs), which are composed of small molecule or polymeric OLEDs as disclosed in but not limited to U.S. Patent No. 4,769,292, by Tang et al., and U.S. Patent No. 5,061,569, by VanSlyke et al. Many combinations and variations of organic light emitting materials can be used to fabricate such a display. When the EL emitter 50 is an OLED emitter, the EL subpixel 60 is an OLED subpixel.

35 **[0068]** The invention has been described in detail with particular reference to certain preferred embodiments thereof, but it will be understood that variations and modifications can be effected within the scope of the invention. For example, the embodiment shown in FIG. 4 is a non-inverted, NMOS subpixel. Other configurations as known in the art can be employed with the present invention. The EL emitter 50 can be an OLED emitter or other emitter types known in the art. The drive transistor 70, and the other transistors (80, 90) can be low-temperature polysilicon (LTPS), zinc oxide (ZnO), or amorphous silicon (a-Si) transistors, or transistors of another type known in the art. Each transistor (70, 80, 90) can be N-channel or P-channel, and the EL emitter 50 can be connected to the drive transistor 70 in an inverted or non-

inverted arrangement. In an inverted configuration as known in the art, the polarities of the first and second power supplies are reversed, and the EL emitter 50 conducts current towards the drive transistor rather than away from it. Current source 160 of the present invention therefore sources a negative current, that is, behaves as a current sink, to draw current through the EL emitter 50. Similarly, current sink 165 sinks a negative current, that is, behaves as a current source, to force current through the drive transistor 70.

[0069] Variations and modifications of digital drive schemes can exist and are also within the scope of this invention. For example, the on-time of each subpixel can be continuous rather than divided into subframes, or the subframes can be in various orders. Longer subframes can be divided into multiple sub-windows, as is known in the art.

[0070] The invention has been described in detail with particular reference to certain preferred embodiments thereof, but it will be understood that variations and modifications can be effected within the scope of the invention as defined by the claims.

PARTS LIST

[0071]

- 2 curve fit
- 10 EL display
- 20 select line
- 30 30 readout line
- 35 data line
- 40 multiplexer
- 45 multiplexer output line
- 50 EL emitter
- 25 60 EL subpixel
- 65 temperature sensor
- 70 drive transistor
- 75 capacitor
- 80 readout transistor
- 30 85 input signal
- 90 select transistor
- 95 control line
- 110 first switch
- 120 second switch
- 35 130 third switch
- 131 fourth switch
- 140 first voltage source
- 150 second voltage source
- 155 driver circuit
- 40 160 current source
- 165 current sink
- 170 voltage measurement circuit
- 180 low-pass filter
- 185 analog-to-digital converter
- 45 190 processor
- 195 memory
- 310 step
- 315 step
- 320 step
- 50 322 step
- 325 step
- 330 decision step
- 332 decision step
- 335 decision step
- 55 340 step
- 345 step
- 350 step
- 355 decision step

	360	decision step
	370	step
	375	step
	380	step
5	385	step
	410	axis
	420	frame period
	430	axis
	440	subframe
10	450	subframe
	460	subframe
	470	subframe
	601	drive transistor load line
	602	unaged OLED load line
15	603	aged OLED load line
	610	point
	611	point
	621	point
	622	point
20	623	point
	624	point
	625	point
	631	voltage
	632	voltage
25	640	linear fit
	641	linear fit
	642	linear fit
	680a	voltage interval
	680b	voltage interval
30	681a	current interval
	681b	current interval
	690	first current
	691	second current
	692	test current
35	693	aged current

Claims

- 40 1. A method of compensating for variations in characteristics of an electroluminescent (EL) emitter (50) in an EL subpixel (60), comprising the steps of:
- (a) providing the EL subpixel (60) having a drive transistor (70), the EL emitter (50), and a readout transistor (80), wherein the drive transistor (70) has a first electrode, a second electrode, and a gate electrode;
- 45 (b) providing a first voltage source (140) and a first switch (110) for selectively connecting the first voltage source (140) to the first electrode of the drive transistor (70);
- (c) connecting a first electrode of the EL emitter (50) to the second electrode of the drive transistor (70);
- (d) providing a second switch (120) for selectively connecting a second electrode of the EL emitter (50) to a second voltage source (150);
- 50 (e) connecting the first electrode of the readout transistor (80) to the second electrode of the drive transistor (70);
- (f) providing a current source (160) and a third switch (130) for selectively connecting the current source (160) to the second electrode of the readout transistor (80), wherein the current source (160) provides a selected test current to the EL emitter (50);
- 55 (g) providing a current sink (165) and a fourth switch (131) for selectively connecting the current sink (165) to the second electrode of the readout transistor (80);
- (h) providing a voltage measurement circuit (170) connected to the second electrode of the readout transistor (80);
- (i) opening the first switch (110), closing the third switch (130), closing the second switch (120) and opening

the fourth switch (131), and in response to the voltage measurement circuit (170) measuring the voltage at the second electrode of the readout transistor (80) providing a first emitter- voltage signal, wherein step (i) further includes:

- 5 - measuring the voltage at the second electrode of the readout transistor (80) at a first time to provide the first emitter-voltage signal;
- storing the first emitter-voltage signal;
- measuring the voltage at the second electrode of the readout transistor (80) at a second time to provide a second emitter-voltage signal, wherein the second time is different from the first time; and
- 10 - storing the second emitter- voltage signal;

(j) using the first emitter- voltage signal and the second emitter-voltage signal to provide an aging signal representative of characteristics of the EL emitter (50);

(k) receiving an input signal;

15 (l) using the aging signal and the input signal to produce a compensated drive signal;

(m) providing a selected drive voltage to the gate electrode of the drive transistor (70) for a selected on-time corresponding to the compensated drive signal, wherein the selected drive voltage causes the drive transistor (70) to operate in a linear region during the selected on-time, to compensate for variations in characteristics of the EL emitter (50); and the method further comprising the steps of:

20 (n) closing the first switch (110), opening the second switch (120), opening the third switch (130), and closing the fourth switch (131), and providing a selected test voltage to the gate electrode of the drive transistor (70);

(o) using the current sink (165) to cause a selected first current to pass through the first and second electrodes of the drive transistor (70), and measuring the voltage at the second electrode of the readout transistor (80) to provide a first transistor-voltage signal; and

25 (p) using the current sink (165) to cause a selected second current to pass through the first and second electrodes of the drive transistor (70), and measuring the voltage at the second electrode of the readout transistor (80) to provide a second transistor-voltage signal, wherein the second current is not equal to the first current;

30 wherein step (j) further includes additionally using the first and second transistor-voltage signals to provide the aging signal.

2. The method of claim 1, wherein the variations in characteristics of the EL emitter (50) are caused by aging of the EL emitter (50).

35 3. The method of claim 1, wherein the variations in characteristics of the EL emitter (50) are caused by variations in the temperature of the EL emitter (50).

4. The method of claim 1, wherein the voltage measurement circuit (170) includes an analog-to-digital converter (185).

40 5. The method of claim 1, further including providing a plurality of EL subpixels (60), wherein steps (i) and (j) are performed for each EL subpixel (60) to produce a plurality of corresponding aging signals, and wherein steps (k) through (m) are performed for each of the plurality of subpixels (60) using the corresponding aging signals.

45 6. The method of claim 5, wherein step (i) is performed for a plurality of such EL subpixels (60) during which the current source (160) provides the selected test current to the respective EL emitters (50) in each of the plurality of EL subpixels (60) simultaneously.

50 7. The method of claim 5, wherein the EL subpixels (60) are arranged in rows and columns and wherein each EL subpixel (60) has a corresponding select transistor (90), and further including providing a plurality of row select lines (20) connected to the gate electrodes of the corresponding select transistors (90) and a plurality of readout lines (30) connected to the second electrodes of corresponding readout transistors (80).

55 8. The method of claim 5, further including providing a plurality of data lines (35) connected to respective first electrodes of the corresponding select transistors, and wherein step (m) includes providing a driver circuit (155) having a gate driver connected to the row select lines, and a source driver connected to the data lines, for providing the selected drive voltage to the gate electrode of the drive transistor.

9. The method of claim 5, further including using a multiplexer (40) connected to the plurality of readout lines (30) for

sequentially measuring each of the plurality of EL subpixels (60) to provide corresponding first emitter-voltage signals.

10. The method of claim 1, further including providing a select transistor (90) connected to the gate electrode of the drive transistor (70), and wherein the gate electrode of the select transistor (90) is connected to the gate electrode of the readout transistor (80).

11. The method of claim 1, wherein the selected on-time is divided into a plurality of activated subframes (440, 450, 460, 470) having respective subframe durations, wherein the sum of the respective subframe durations equals the selected on-time.

12. The method of claim 1, further including providing a drive transistor load line (601), and wherein step (j) further includes additionally using the drive transistor load line (601) to provide the aging signal.

Patentansprüche

1. Verfahren zum Kompensieren von Variationen in Eigenschaften eines elektrolumineszenten (EL) Emitters (50) in einem EL-Unterpixel (60), umfassend die Schritte:

(a) Bereitstellen des EL-Unterpixels (60) mit einem Treibtransistor (70), dem EL-Emitter (50) und einem Auslesetransistor (80), wobei der Treibtransistor (70) eine erste Elektrode, eine zweite Elektrode und eine Gate-Elektrode aufweist;

(b) Bereitstellen einer ersten Spannungsquelle (140) und eines ersten Schalters (110) zur selektiven Verbindung der ersten Spannungsquelle (140) mit der ersten Elektrode des Treibtransistors (70);

(c) Verbinden einer ersten Elektrode des EL-Emitters (50) mit der zweiten Elektrode des Treibtransistors (70);

(d) Bereitstellen eines zweiten Schalters (120) zum selektiven Verbinden einer zweiten Elektrode des EL-Emitters (50) mit einer zweiten Spannungsquelle (150);

(e) Verbinden der ersten Elektrode des Auslesetransistors (80) mit der zweiten Elektrode des Treibtransistors (70);

(f) Bereitstellen einer Stromquelle (160) und eines dritten Schalters (130) zum selektiven Verbinden der Stromquelle (160) mit der zweiten Elektrode des Auslesetransistors (80), wobei die Stromquelle (160) einen ausgewählten Teststrom für den EL-Emitter (50) bereitstellt;

(g) Bereitstellen einer Stromsenke (165) und eines vierten Schalters (131) zum selektiven Verbinden der Stromsenke (165) mit der zweiten Elektrode des Auslesetransistors (80);

(h) Bereitstellen einer Spannungsmessschaltung (170), die mit der zweiten Elektrode des Auslesetransistors (80) verbunden ist;

(i) Öffnen des ersten Schalters (110), Schließen des dritten Schalters (130), Schließen des zweiten Schalters (120) und Öffnen des vierten Schalters (131), und in Antwort auf das Messen, durch die Spannungsmessschaltung (170), der Spannung an der zweiten Elektrode des Auslesetransistors (80), der ein erstes Emitterspannungssignal bereitstellt, wobei Schritt (i) weiterhin umfasst:

- Messen der Spannung an der zweiten Elektrode des Auslesetransistors (80) zu einem ersten Zeitpunkt, um das erste Emitterspannungssignal bereitzustellen;

- Speichern des ersten Emitterspannungssignals;

- Messen der Spannung an der zweiten Elektrode des Auslesetransistors (80) zu einem zweiten Zeitpunkt, um ein zweites Emitterspannungssignal bereitzustellen, wobei der zweite Zeitpunkt von dem ersten Zeitpunkt verschieden ist; und

- Speichern des zweiten Emitterspannungssignals;

(j) Verwenden des ersten Emitterspannungssignals und des zweiten Emitterspannungssignals, um ein Alterungssignal bereitzustellen, das Eigenschaften des EL-Emitters (50) darstellt;

(k) Empfangen eines Eingangssignals;

(l) Verwenden des Alterungssignals und des Eingangssignals, um ein kompensiertes Treibsignal zu erzeugen;

(m) Bereitstellen einer ausgewählten Treibspannung für die Gate-Elektrode des Treibtransistors (70) für eine ausgewählte Ein-Zeit entsprechend dem kompensierten Treibsignal, wobei die ausgewählte Treibspannung den Treibtransistor (70) veranlasst, in einem linearen Bereich während der ausgewählten Ein-Zeit zu operieren, um Variationen in den Eigenschaften des EL-Emitters (50) zu kompensieren; und wobei das Verfahren weiterhin die Schritte umfasst:

(n) Schließen des ersten Schalters (110), Öffnen des zweiten Schalters (120), Öffnen des dritten Schalters (130) und Schließen des vierten Schalters (131) und Bereitstellen einer ausgewählten Testspannung für die Gate-Elektrode des Treibtransistors (70);

(o) Verwenden der Stromsenke (165), um zu veranlassen, dass ein erster ausgewählter Strom durch die erste und zweite Elektrode des Treibtransistors (70) fließt, und Messen der Spannung an der zweiten Elektrode des Auslesetransistors (80), um ein erstes Transistorspannungssignal bereitzustellen; und

(p) Verwenden der Stromsenke (165), um zu veranlassen, dass ein ausgewählter zweiter Strom durch die erste und zweite Elektrode des Treibtransistors (70) fließt, und Messen der Spannung an der zweiten Elektrode des Auslesetransistors (80), um ein zweites Transistorspannungssignal bereitzustellen, wobei der zweite Strom nicht gleich dem ersten Strom ist;

wobei Schritt (j) weiterhin umfasst zusätzliches Verwenden der ersten und zweiten Transistorspannungssignale, um das Alterungssignal bereitzustellen.

2. Verfahren gemäß Anspruch 1, wobei die Variationen in den Eigenschaften des EL-Emitters (50) durch die Alterung des EL-Emitters (50) verursacht werden.

3. Verfahren gemäß Anspruch 1, wobei die Variationen in den Eigenschaften des EL-Emitters (50) durch Variationen in der Temperatur des EL-Emitters (50) verursacht werden.

4. Verfahren gemäß Anspruch 1, wobei die Spannungsmessschaltung (170) einen Analog-zu-Digital-Wandler (185) umfasst.

5. Verfahren gemäß Anspruch 1, weiterhin umfassend Bereitstellen einer Vielzahl von EL-Unterpixeln (60), wobei die Schritte (i) und (j) für jedes EL-Unterpixel (60) durchgeführt werden, um eine Vielzahl von entsprechenden Alterungssignalen zu erzeugen, und wobei die Schritte (k) bis (m) für jedes der Vielzahl von Unterpixeln (60) unter Verwendung der entsprechenden Alterungssignale durchgeführt wird.

6. Verfahren gemäß Anspruch 5, wobei der Schritt (i) für eine Vielzahl derartiger EL-Unterpixel (60) durchgeführt wird, während dem die Stromquelle (160) den ausgewählten Teststrom für die jeweiligen EL-Emitter (50) in jedem der Vielzahl von EL-Unterpixeln (60) gleichzeitig bereitstellt.

7. Verfahren gemäß Anspruch 5, wobei die EL-Unterpixel (60) in Zeilen und Spalten angeordnet sind, und wobei jedes EL-Unterpixel (60) einen entsprechenden Auswahltransistor (90) aufweist, und weiterhin umfassend Bereitstellen einer Vielzahl von Zeilenauswahlleitungen (20), die mit den Gate-Elektroden der jeweiligen Auswahltransistoren (90) verbunden sind, und einer Vielzahl von Ausleseleitungen (30), die mit den zweiten Elektroden von jeweiligen Auslesetransistoren (80) verbunden sind.

8. Verfahren gemäß Anspruch 5, weiterhin umfassend Bereitstellen einer Vielzahl von Datenleitungen (35), die mit jeweiligen ersten Elektroden der entsprechenden Auswahltransistoren verbunden sind, und wobei der Schritt (m) umfasst Bereitstellen einer Treiberschaltung (155) mit einem Gate-Treiber, der mit den Zeilenauswahlleitungen verbunden ist, und eines Quelltreibers, der mit den Datenleitungen verbunden ist, um die ausgewählte Treibspannung für die Gate-Elektrode des Treibtransistors bereitzustellen.

9. Verfahren gemäß Anspruch 5, weiterhin umfassend Verwenden eines Multiplexers (40), der mit der Vielzahl von Ausleseleitungen (30) verbunden ist, um sequenziell jedes der Vielzahl von EL-Unterpixeln (60) zu messen, um entsprechende erste Emitterspannungssignale bereitzustellen.

10. Verfahren gemäß Anspruch 1, weiterhin umfassend Bereitstellen eines Auswahltransistors (90), der mit der Gate-Elektrode des Treibtransistors (70) verbunden ist, und wobei die Gate-Elektrode des Auswahltransistors (90) mit der Gate-Elektrode des Ausle-

setransistors (80) verbunden ist.

11. Verfahren gemäß Anspruch 1,
wobei die ausgewählte Ein-Zeit in eine Vielzahl von aktivierten Unterrahmen (440, 450, 460, 470) mit jeweiligen
Unterrahmendauern unterteilt wird, wobei die Summe der jeweiligen Unterrahmendauern gleich der ausgewählten
Ein-Zeit ist.

12. Verfahren gemäß Anspruch 1,
weiterhin umfassend Bereitstellen einer Treibtransistorlastleitung (601), und wobei der Schritt (j) weiterhin umfasst
zusätzliches Verwenden der Treibtransistorlastleitung (601), um das Alterungssignal bereitzustellen.

Revendications

1. Procédé de compensation de variations de caractéristiques d'un émetteur (50) électroluminescent (EL) dans un
sous-pixel (60) EL, comprenant les étapes de :

(a) prévision du sous-pixel (60) EL ayant un transistor (70) de pilotage, l'émetteur (50) EL, et un transistor (80)
de lecture, dans lequel le transistor (70) de pilotage a une première électrode, une deuxième électrode, et une
électrode de grille ;

(b) prévision d'une première source (140) de tension et d'un premier commutateur (110) pour sélectivement
connecter la première source (140) de tension à la première électrode du transistor (70) de pilotage ;

(c) connexion d'une première électrode de l'émetteur (50) EL à la deuxième électrode du transistor (70) de
pilotage ;

(d) prévision d'un deuxième commutateur (120) pour sélectivement connecter une deuxième électrode de
l'émetteur (50) EL à une deuxième source (150) de tension ;

(e) connexion de la première électrode du transistor (80) de lecture à la deuxième électrode du transistor (70)
de pilotage ;

(f) prévision d'une source (160) de courant et d'un troisième commutateur (130) pour sélectivement connecter
la source (160) de courant à la deuxième électrode du transistor (80) de lecture, dans lequel la source (160)
de courant fournit un courant de test sélectionné à l'émetteur (50) EL ;

(g) prévision d'un collecteur (165) de courant et d'un quatrième commutateur (131) pour sélectivement connecter
le collecteur (165) de courant à la deuxième électrode du transistor (80) de lecture ;

(h) prévision d'un circuit (170) de mesure de tension connecté à la deuxième électrode du transistor (80) de
lecture ;

(i) ouverture du premier commutateur (110), fermeture du troisième commutateur (130), fermeture du deuxième
commutateur (120) et ouverture du quatrième commutateur (131), et, en réponse au circuit (170) de mesure
de tension mesurant la tension à la deuxième électrode du transistor (80) de lecture, délivrance d'un premier
signal de tension d'émetteur, et dans lequel l'étape (i) inclut en outre :

- la mesure de la tension à la deuxième électrode du transistor (80) de lecture à un premier instant pour
donner le premier signal de tension d'émetteur ;

- le stockage du premier signal de tension d'émetteur ;

- la mesure de la tension à la deuxième électrode du transistor (80) de lecture à un deuxième instant pour
donner un deuxième signal de tension d'émetteur, dans lequel le deuxième instant est différent du premier
instant ;

et

- le stockage du deuxième signal de tension d'émetteur ;

(j) utilisation du premier signal de tension d'émetteur et du deuxième signal de tension d'émetteur pour donner
un signal de vieillissement représentatif de caractéristiques de l'émetteur (50) EL ;

(k) réception d'un signal d'entrée ;

(l) utilisation du signal de vieillissement et du signal d'entrée pour produire un signal de pilotage compensé ;

(m) délivrance d'une tension de pilotage sélectionnée à l'électrode de grille du transistor (70) de pilotage sur
une durée d'activité sélectionnée correspondant au signal de pilotage compensé, dans lequel la tension de
pilotage sélectionnée fait que le transistor (70) de pilotage fonctionne dans une région linéaire pendant la durée
d'activité sélectionnée, pour compenser des variations de caractéristiques de l'émetteur (50) EL ; et le procédé
comprenant en outre les étapes de :

(n) fermeture du premier commutateur (110), ouverture du deuxième commutateur (120), ouverture du troisième commutateur (130) et fermeture du quatrième commutateur (131), et délivrance d'une tension de test sélectionnée à l'électrode de grille du transistor (70) de pilotage ;

5 (o) utilisation du collecteur (165) de courant pour faire qu'un premier courant sélectionné passe à travers les première et deuxième électrodes du transistor (70) de pilotage, et mesure de la tension à la deuxième électrode du transistor (80) de lecture pour donner un premier signal de tension de transistor ; et

10 (p) utilisation du collecteur (165) de courant pour faire qu'un deuxième courant sélectionné passe à travers les première et deuxième électrodes du transistor (70) de pilotage, et mesure de la tension à la deuxième électrode du transistor (80) de lecture pour donner un deuxième signal de tension de transistor, dans lequel le deuxième courant n'est pas égal au premier courant ;

dans lequel l'étape (j) inclut en outre additionnellement l'utilisation des premier et deuxième signaux de tension de transistor pour donner le signal de vieillissement.

15 **2.** Procédé selon la revendication 1, dans lequel les variations de caractéristiques de l'émetteur (50) EL sont causées par le vieillissement de l'émetteur (50) EL.

3. Procédé selon la revendication 1, dans lequel les variations de caractéristiques de l'émetteur (50) EL sont causées par des variations de la température de l'émetteur (50) EL.

20 **4.** Procédé selon la revendication 1, dans lequel le circuit (170) de mesure de tension inclut un convertisseur (185) analogique à numérique.

25 **5.** Procédé selon la revendication 1, incluant en outre la prévision d'une pluralité de sous-pixels (60) EL, dans lequel les étapes (i) et (j) sont mises en oeuvre pour chaque sous-pixel (60) EL pour produire une pluralité de signaux de vieillissement correspondants, et dans lequel les étapes (k) à (m) sont mises en oeuvre pour chacun de la pluralité de sous-pixels (60) EL en utilisant les signaux de vieillissement correspondants.

30 **6.** Procédé selon la revendication 5, dans lequel l'étape (i) est mise en oeuvre pour une pluralité de tels sous-pixels (60) EL, pendant laquelle la source (160) de courant délivre le courant de test sélectionné aux émetteurs (50) EL respectifs dans chacun de la pluralité de sous-pixels (60) EL simultanément.

35 **7.** Procédé selon la revendication 5, dans lequel les sous-pixels (60) EL sont agencés en rangées et colonnes et dans lequel chaque sous-pixel (60) EL a un transistor (90) de sélection correspondant, et incluant en outre la prévision d'une pluralité de lignes (20) de sélection de rangée connectées aux électrodes de grille des transistors (90) de sélection correspondants et une pluralité de lignes (30) de lecture connectées aux deuxième électrodes de transistors (80) de lecture correspondants.

40 **8.** Procédé selon la revendication 5, incluant en outre la prévision d'une pluralité de lignes (35) de données connectées à des premières électrodes respectives des transistors de sélection correspondants, et dans lequel l'étape (m) inclut la prévision d'un circuit (155) de pilotage ayant un dispositif de pilotage de grille connecté aux lignes de sélection de rangée, et un dispositif de pilotage de source connecté aux lignes de données, pour délivrer la tension de pilotage sélectionnée à l'électrode de grille du transistor de pilotage.

45 **9.** Procédé selon la revendication 5, incluant en outre l'utilisation d'un multiplexeur (40) connecté à la pluralité de lignes (30) de lecture pour mesurer séquentiellement chacun de la pluralité de sous-pixels (60) EL pour donner des premiers signaux de tension d'émetteur correspondants.

50 **10.** Procédé selon la revendication 1, incluant en outre la prévision d'un transistor (90) de sélection connecté à l'électrode de grille du transistor (70) de pilotage, et dans lequel l'électrode de grille du transistor (90) de sélection est connectée à l'électrode de grille du transistor (80) de lecture.

55 **11.** Procédé selon la revendication 1, dans lequel la durée d'activité sélectionnée est divisée en une pluralité de sous-trames (440, 450, 460, 470) activées ayant des durées de sous-trame respectives, dans lequel la somme des durées de sous-trame respectives est égale à la durée d'activité sélectionnée.

12. Procédé selon la revendication 1, incluant en outre la prévision d'une ligne (601) de charge de transistor de pilotage, et dans lequel l'étape (j) inclut en outre additionnellement l'utilisation de la ligne (601) de charge de transistor de

pilotage pour donner le signal de vieillissement.

5

10

15

20

25

30

35

40

45

50

55

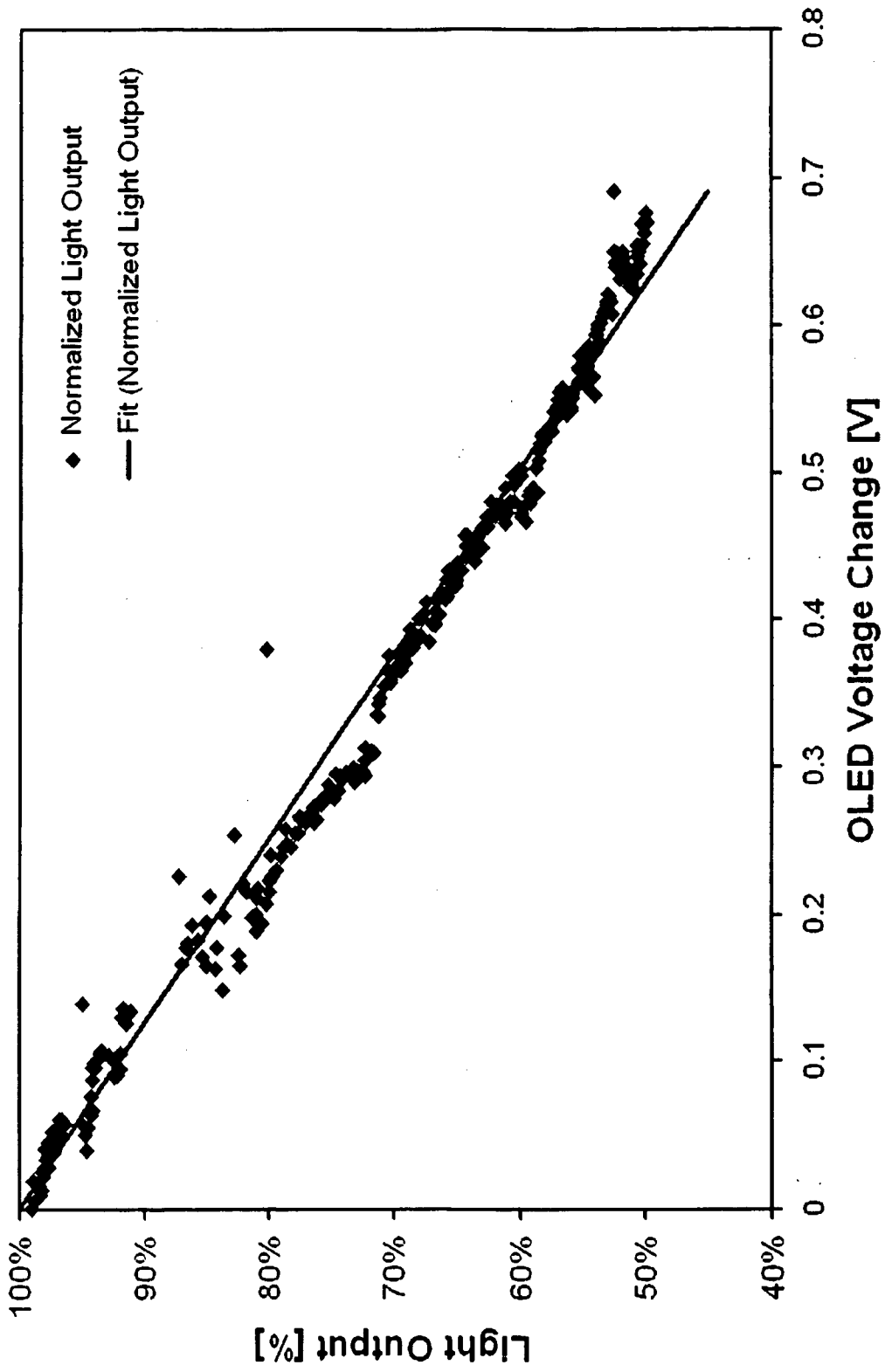

FIG. 1

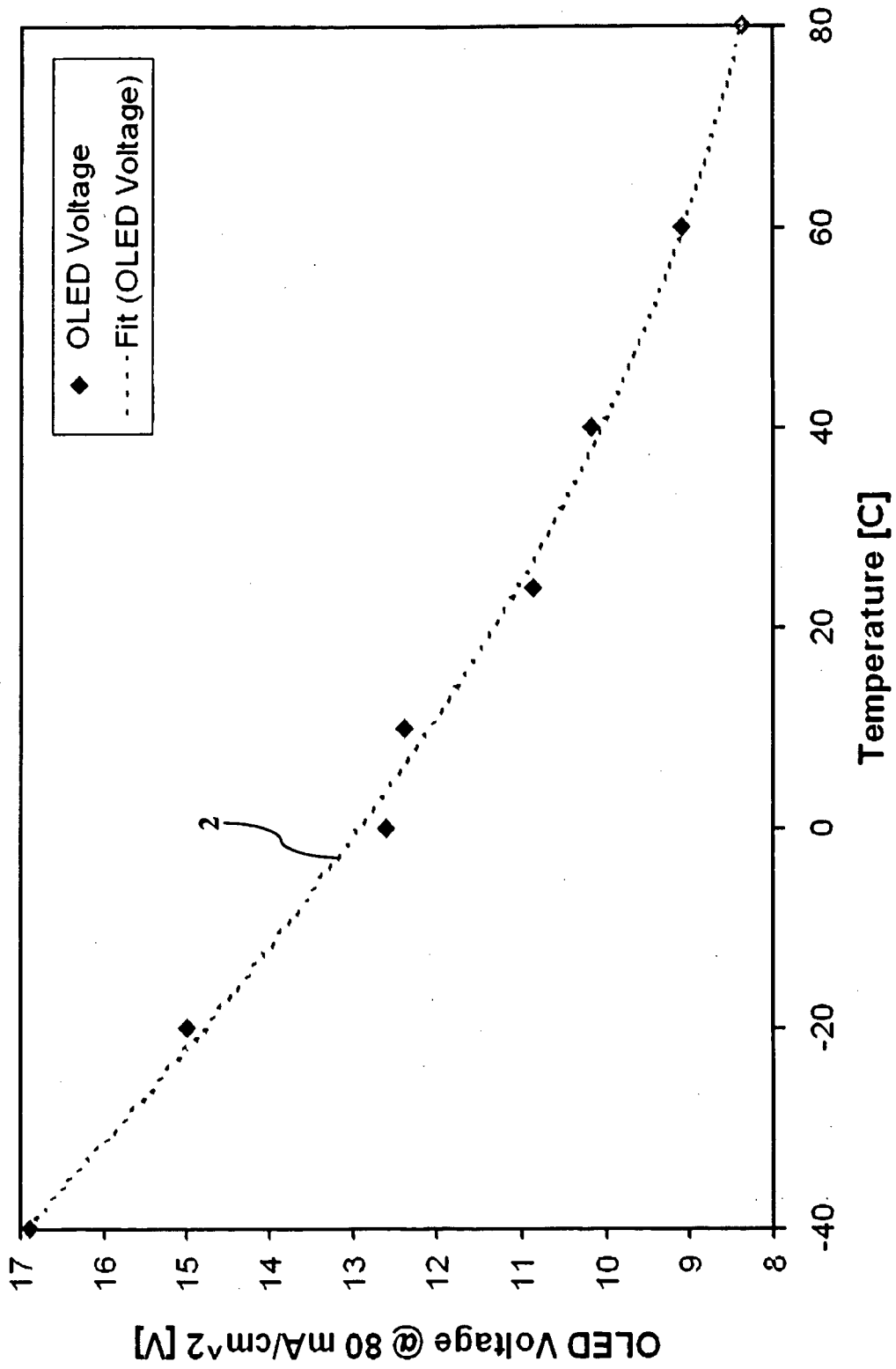

FIG. 2

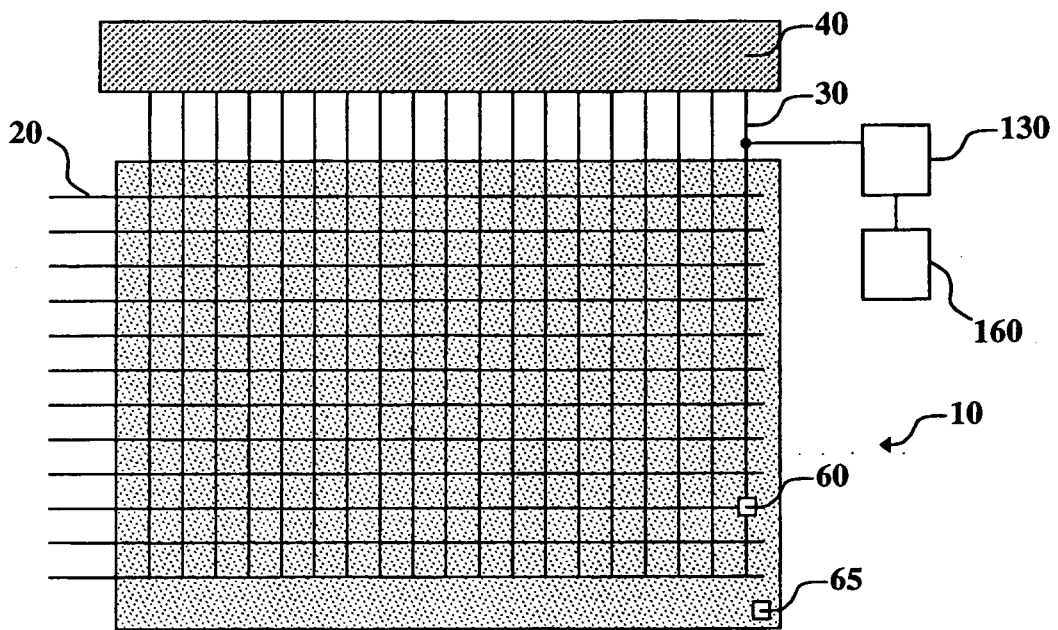

FIG. 3

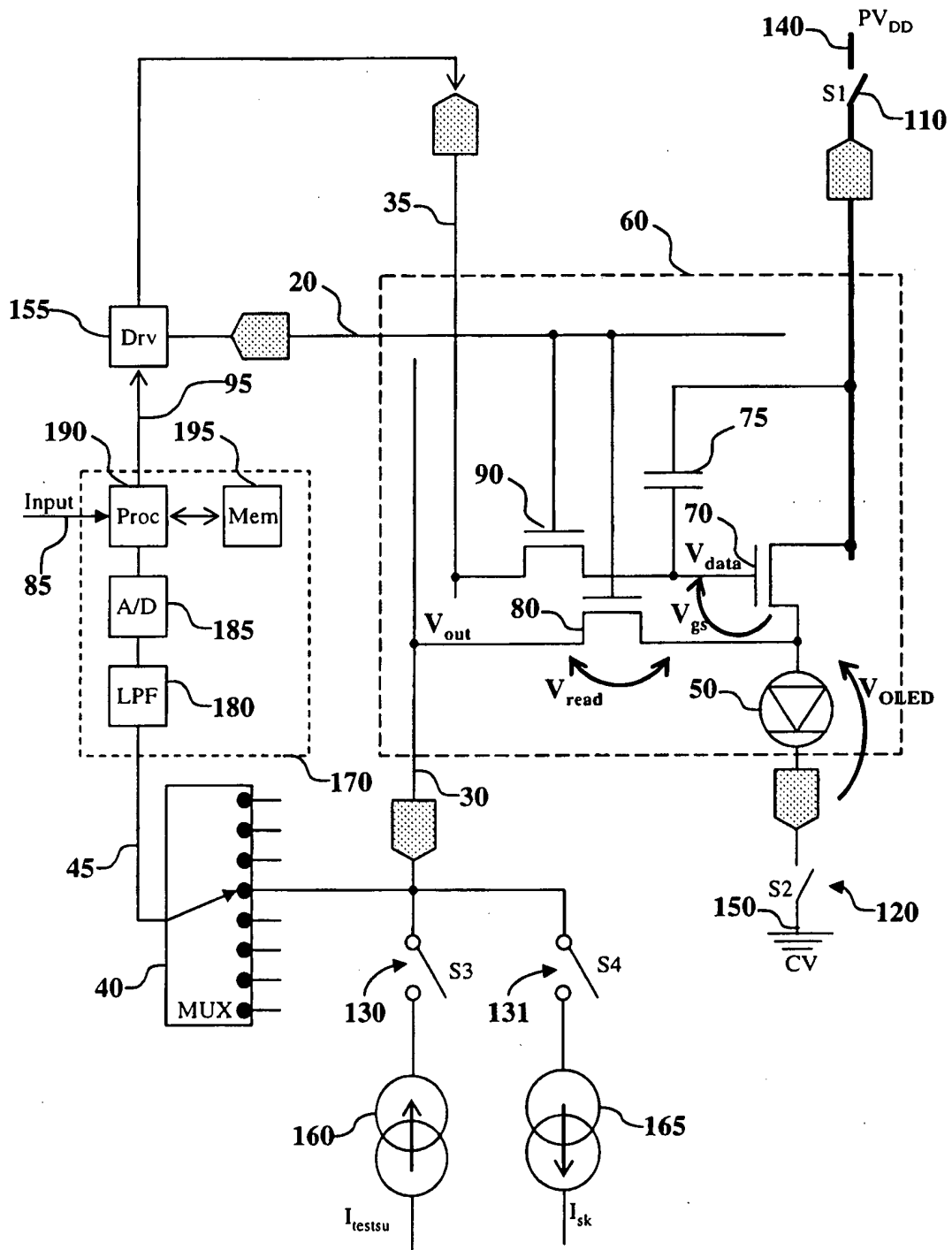

FIG. 4

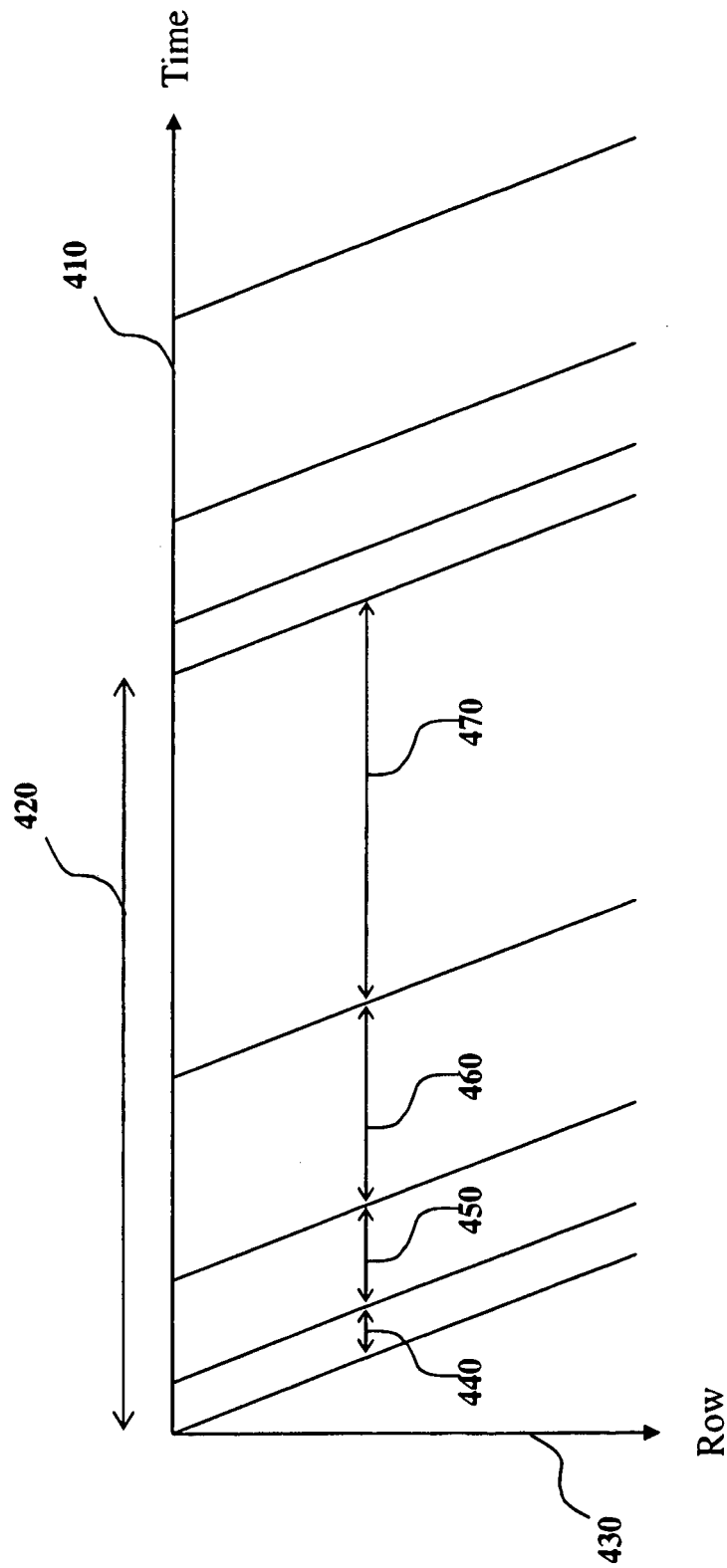

FIG. 5
(PRIOR ART)

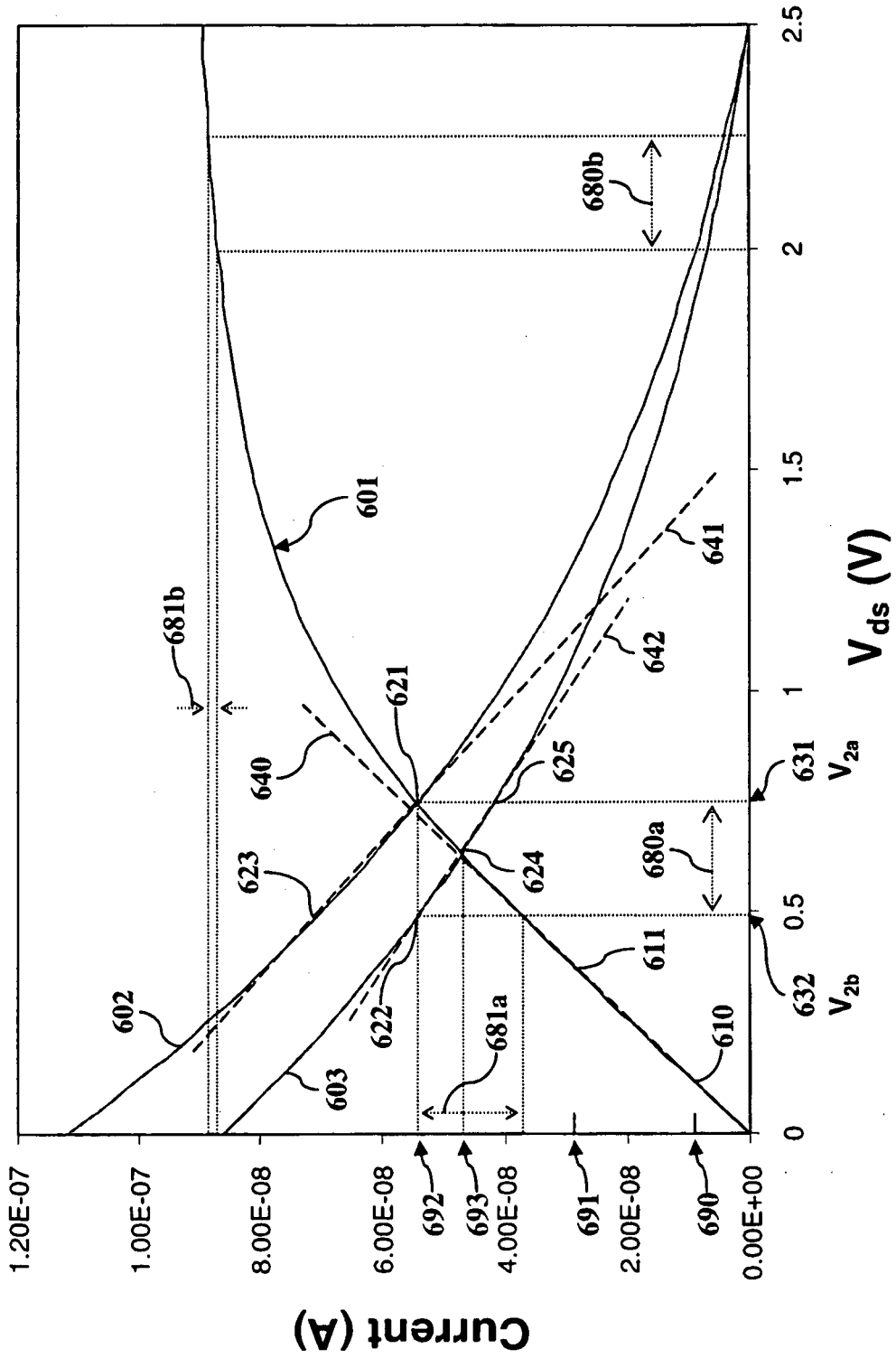

FIG. 6

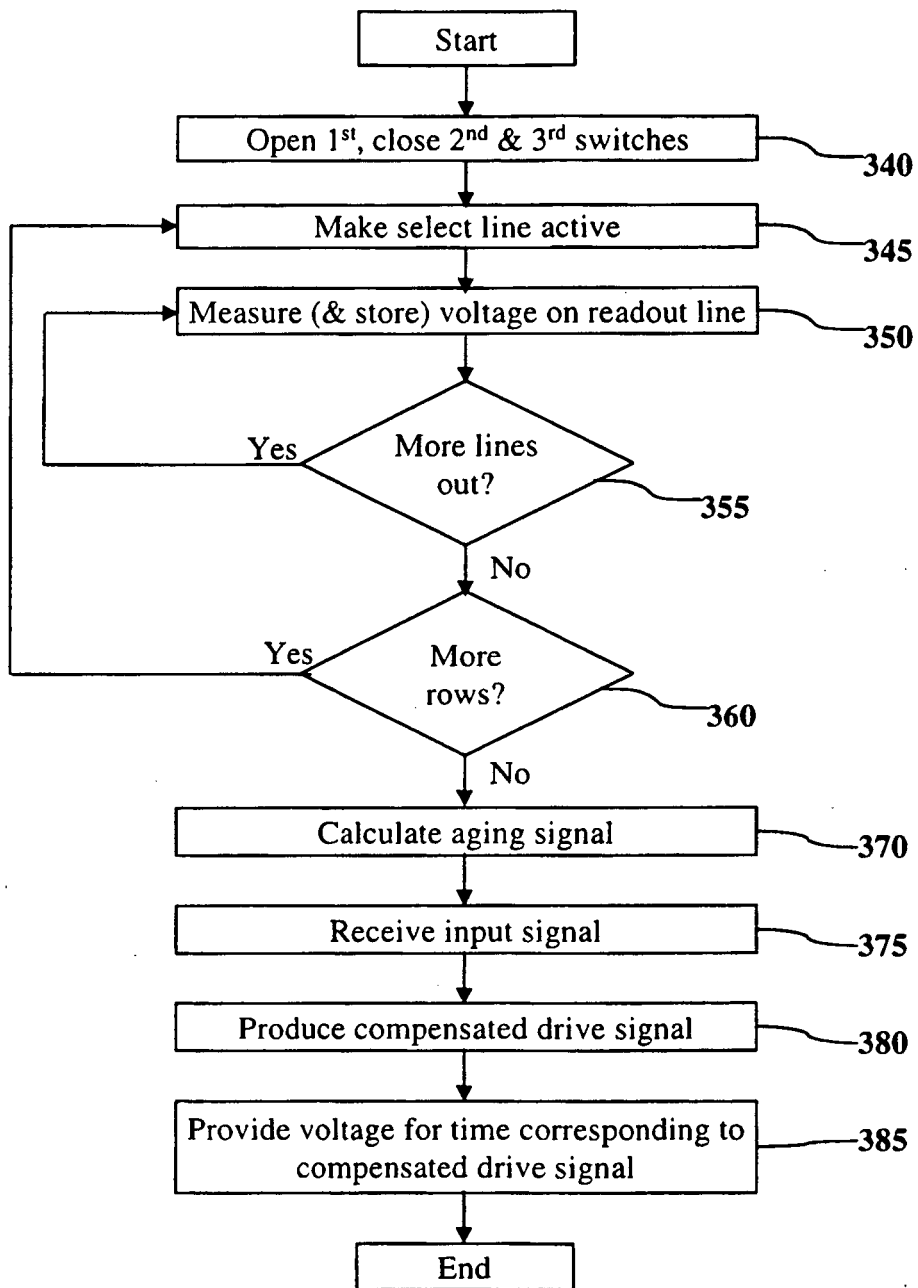

FIG. 7A

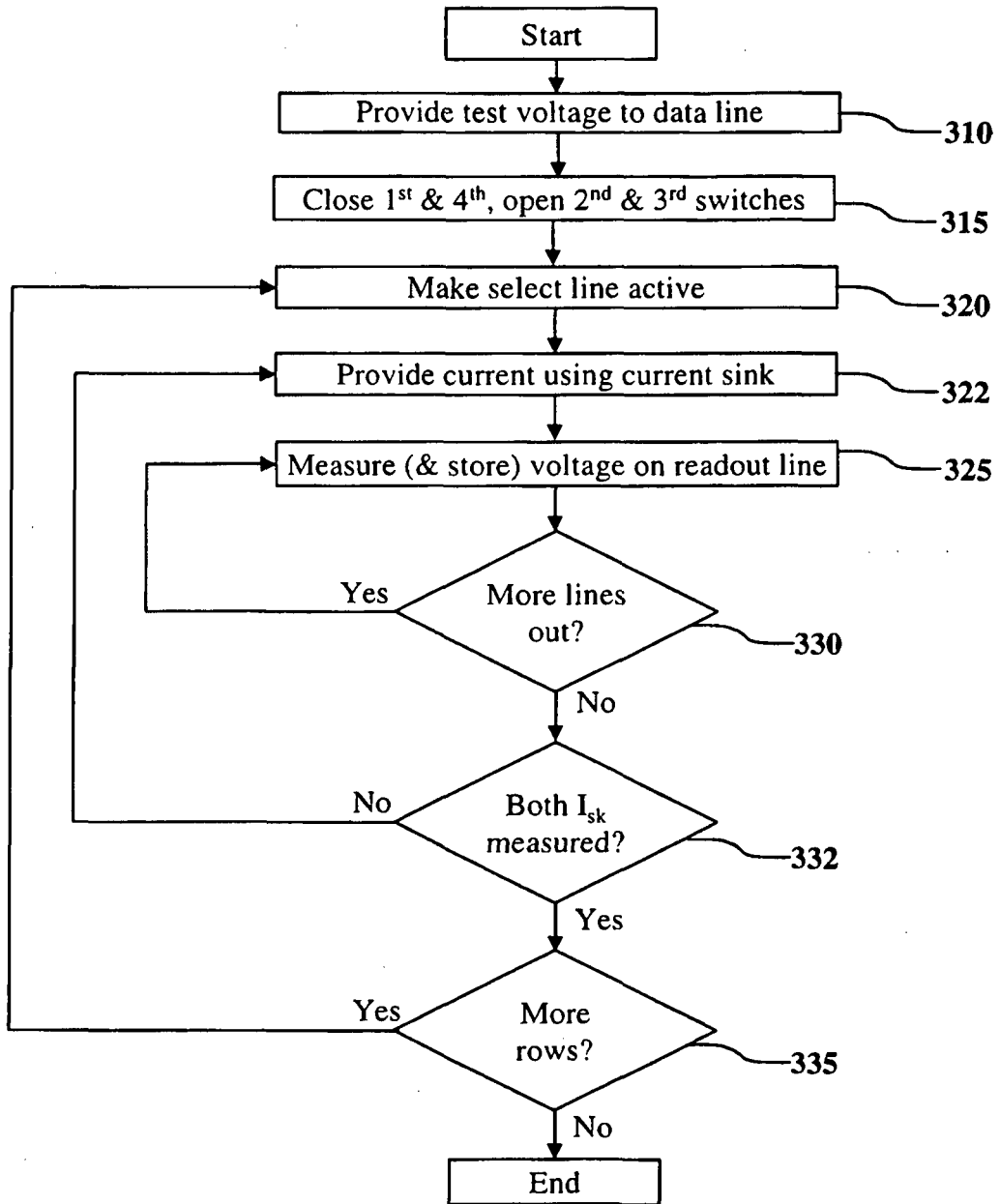

FIG. 7B

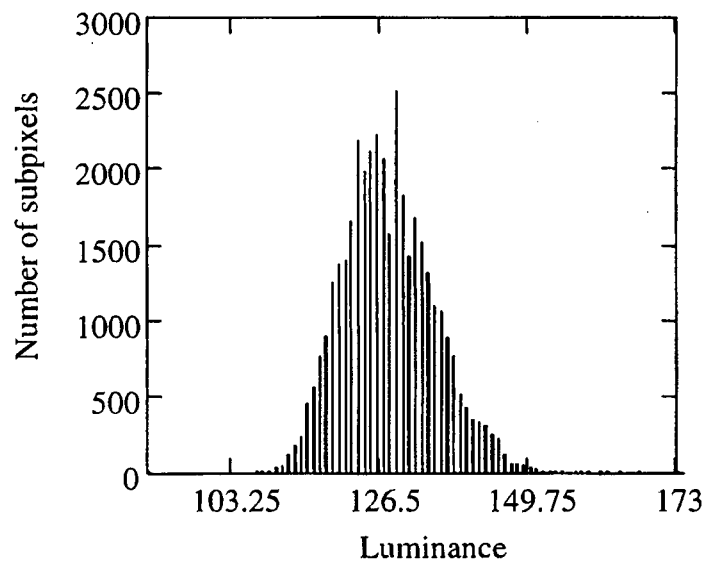

FIG. 8

REFERENCES CITED IN THE DESCRIPTION

This list of references cited by the applicant is for the reader's convenience only. It does not form part of the European patent document. Even though great care has been taken in compiling the references, errors or omissions cannot be excluded and the EPO disclaims all liability in this regard.

Patent documents cited in the description

- US 6724377 B, Ouchi [0005]
- US 6885385 B [0005]
- US 2008088561 A [0006]
- US 20020140659 A, Mikami [0009]
- US 7138967 B, Kimura [0010]
- US 20060022305 A, Yamashita [0011]
- US 20020167474 A, Everitt [0012]
- US 6995519 B, Arnold [0013]
- US 20080048951 A, Naugler [0014]
- EP 2026319 A1 [0015]
- US 2008252568 A1 [0016]
- US 2008122759 A1 [0017]
- US 2005179628 A1 [0018]
- US 2006170623 A1 [0019]
- US 4769292 A, Tang [0067]
- US 5061569 A, VanSlyke [0067]

Non-patent literature cited in the description

- Thin Film Transistors: Materials and Processes, vol. 2: Polycrystalline Thin Film Transistors. Kluwer Academic Publishers, 2004, 410-412 [0003]

专利名称(译)	具有老化补偿功能的数字驱动电致发光显示器		
公开(公告)号	EP2359357B1	公开(公告)日	2015-01-21
申请号	EP2009801841	申请日	2009-12-16
[标]申请(专利权)人(译)	全球OLED TECH		
申请(专利权)人(译)	全球OLED科技有限责任公司		
当前申请(专利权)人(译)	全球OLED科技有限责任公司		
[标]发明人	LEVEY CHARLES I LEON FELIPE ANTONIO HAMER JOHN W PARRETT GARY WHITE CHRISTOPHER JASON		
发明人	LEVEY, CHARLES, I. LEON, FELIPE, ANTONIO HAMER, JOHN, W. PARRETT, GARY WHITE, CHRISTOPHER, JASON		
IPC分类号	G09G3/32		
CPC分类号	G09G3/3233 G09G3/2022 G09G2300/0819 G09G2320/0295 G09G2320/041 G09G2320/043 G09G2320/045		
优先权	12/337668 2008-12-18 US		
其他公开文献	EP2359357A1		
外部链接	Espacenet		

摘要(译)

由数字驱动方案驱动的电致发光 (EL) 子像素具有当驱动晶体管不导通时由电流源驱动的读出晶体管。这产生了一个发射极电压信号，从中可以计算出表示EL发射器效率的老化信号。老化信号用于确定子像素在激活时的电流损失，并且调整输入信号以提供增加的导通时间以补偿EL发射器的电压上升和效率损失。由温度引起的变化也可以得到补偿。

