



(11) **EP 2 261 984 A3**

(12) **EUROPEAN PATENT APPLICATION**

(88) Date of publication A3:  
**05.10.2011 Bulletin 2011/40**

(51) Int Cl.:  
**H01L 27/32** <sup>(2006.01)</sup> **H01L 51/52** <sup>(2006.01)</sup>  
**H01L 51/56** <sup>(2006.01)</sup>

(43) Date of publication A2:  
**15.12.2010 Bulletin 2010/50**

(21) Application number: **10186209.2**

(22) Date of filing: **24.12.2003**

(84) Designated Contracting States:  
**AT BE BG CH CY CZ DE DK EE ES FI FR GB GR HU IE IT LI LU MC NL PT RO SE SI SK TR**

(72) Inventors:  
• **Evers, Marinus Franciscus Johannes**  
**5605 JA, Eindhoven (NL)**  
• **Briër, Peter**  
**5605 JA, Eindhoven (NL)**

(30) Priority: **24.12.2002 NL 1022269**

(62) Document number(s) of the earlier application(s) in accordance with Art. 76 EPC:  
**03789653.7 / 1 581 970**

(74) Representative: **Jansen, Cornelis Marinus et al**  
**VEREENIGDE**  
**Johan de Wittlaan 7**  
**2517 JR Den Haag (NL)**

(71) Applicant: **OTB Group B.V.**  
**5657 EB Eindhoven (NL)**

(54) **Method for manufacturing an organic electroluminescent display device, substrate to be used with such a method and an organic electroluminescent display device obtained with the method**

(57) A method for manufacturing an organic electroluminescent display device, wherein an arrangement of layers is applied to a substrate such, that in a first direction, first conductors extend as well as in a second direction, while between the intersections of the conductors an organic electroluminescent connection has been provided which, under the influence of an electric tension, emits light, the substrate being manufactured from plastic and being provided with a surface structure which forms

a boundary for at least a number of the layers to be applied. The invention also provides a substrate intended for use in a method according to the invention for manufacturing an organic electroluminescent display device, wherein the substrate has been manufactured from plastic and is provided with a surface structure which forms a boundary for at least a number of the layers to be applied. The invention further provides an organic electroluminescent display device obtained with the method.

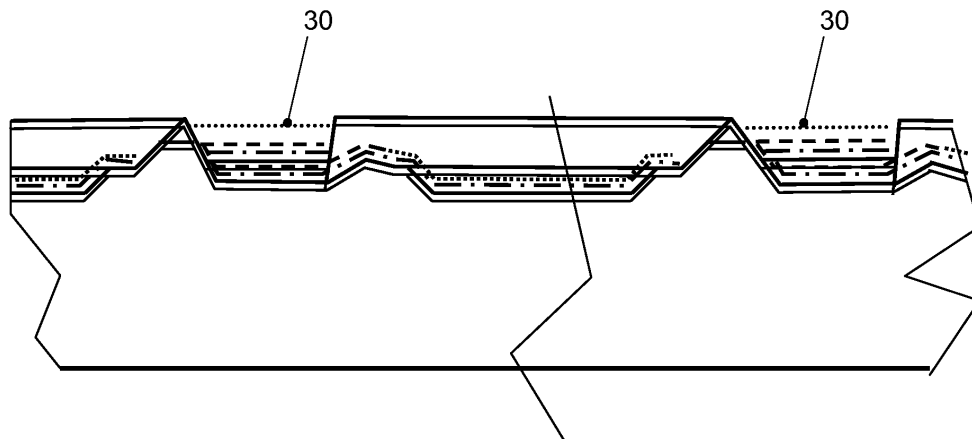

Fig. 29

EP 2 261 984 A3



EUROPEAN SEARCH REPORT

Application Number  
EP 10 18 6209

DOCUMENTS CONSIDERED TO BE RELEVANT			
Category	Citation of document with indication, where appropriate, of relevant passages	Relevant to claim	CLASSIFICATION OF THE APPLICATION (IPC)
X	US 2002/177007 A1 (CHERNOBROD BORIS [US] ET AL) 28 November 2002 (2002-11-28)  * paragraphs [0001], [0005], [0022], [0024], [0026], [0030], [0035]; figures *	1-7, 10-14, 16,17	INV. H01L27/32  ADD. H01L51/52 H01L51/56
X	US 2002/055210 A1 (PENG KUANG-CHUNG [TW]) 9 May 2002 (2002-05-09) * paragraph [0027] - paragraph [0032]; figures 3a-3f *	1,3-17	
			TECHNICAL FIELDS SEARCHED (IPC)
			H01L
The present search report has been drawn up for all claims			
Place of search		Date of completion of the search	Examiner
The Hague		24 August 2011	De Laere, Ann
CATEGORY OF CITED DOCUMENTS		T : theory or principle underlying the invention E : earlier patent document, but published on, or after the filing date D : document cited in the application L : document cited for other reasons ..... & : member of the same patent family, corresponding document	
X : particularly relevant if taken alone Y : particularly relevant if combined with another document of the same category A : technological background O : non-written disclosure P : intermediate document			

1  
EPO FORM 1503 03.02 (P04C01)

**ANNEX TO THE EUROPEAN SEARCH REPORT  
ON EUROPEAN PATENT APPLICATION NO.**

EP 10 18 6209

This annex lists the patent family members relating to the patent documents cited in the above-mentioned European search report. The members are as contained in the European Patent Office EDP file on The European Patent Office is in no way liable for these particulars which are merely given for the purpose of information.

24-08-2011

Patent document cited in search report	Publication date	Patent family member(s)	Publication date
US 2002177007 A1	28-11-2002	AU 2002344290 A8 WO 02097862 A2	08-07-2010 05-12-2002
-----	-----	-----	-----
US 2002055210 A1	09-05-2002	JP 2002151258 A TW 474115 B	24-05-2002 21-01-2002
-----	-----	-----	-----

EPO FORM P0459

For more details about this annex : see Official Journal of the European Patent Office, No. 12/82

专利名称(译)	用于制造有机电致发光显示装置的方法，用于这种方法的基板和利用该方法获得的有机电致发光显示装置		
公开(公告)号	<a href="#">EP2261984A3</a>	公开(公告)日	2011-10-05
申请号	EP2010186209	申请日	2003-12-24
[标]申请(专利权)人(译)	欧提比集团有限公司		
申请(专利权)人(译)	OTB集团B.V.		
当前申请(专利权)人(译)	OTB集团B.V.		
[标]发明人	EVERS MARINUS FRANCISCUS JOHANNES BRIER PETER		
发明人	EVERS, MARINUS FRANCISCUS JOHANNES BRIËR, PETER		
IPC分类号	H01L27/32 H01L51/52 H01L51/56		
CPC分类号	F21V5/045 H01L27/3283 H01L51/0004 H01L51/52 H01L51/5253 H01L51/56 F21V21/00 H01L51/5275		
代理机构(译)	严实， CORNELIS MARINUS		
优先权	1022269 2002-12-24 NL		
其他公开文献	EP2261984A2		
外部链接	<a href="#">Espacenet</a>		

摘要(译)

一种用于制造有机电致发光显示装置的方法，其中层的布置被施加到基板，使得在第一方向上，第一导体以及在第二方向上延伸，而在导体的交叉点之间是有机电致发光连接。本发明提供了一种在电张力的作用下发光的基板，该基板由塑料制成并具有表面结构，该表面结构形成至少许多待施加的层的边界。本发明还提供了一种用于制造有机电致发光显示装置的根据本发明的方法的基板，其中基板由塑料制成并且具有表面结构，该表面结构形成至少一些边界。要应用的图层。本发明还提供了一种用该方法获得的有机电致发光显示装置。

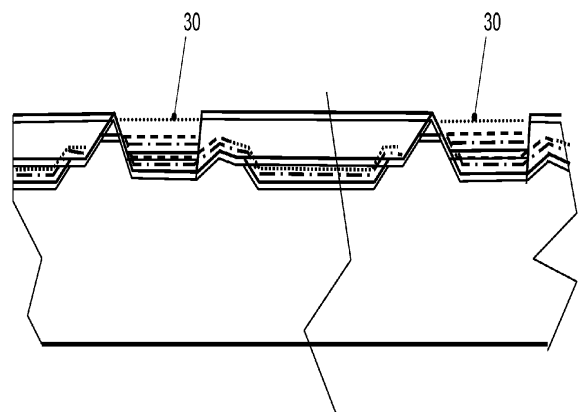

Fig. 29