



(11) **EP 1 662 468 A3**

(12) **EUROPEAN PATENT APPLICATION**

(88) Date of publication A3: **01.10.2008 Bulletin 2008/40** (51) Int Cl.: **G09G 3/32^(2006.01)**

(43) Date of publication A2: **31.05.2006 Bulletin 2006/22**

(21) Application number: **05025577.7**

(22) Date of filing: **23.11.2005**

(84) Designated Contracting States:
AT BE BG CH CY CZ DE DK EE ES FI FR GB GR HU IE IS IT LI LT LU LV MC NL PL PT RO SE SI SK TR
Designated Extension States:
AL BA HR MK YU

(72) Inventors:
• **Yoshifumi, Tanada**
Semiconductor Energy Lab.Co.Ltd.
Atsugi-shi
Kanagawa-ken 243-0036 (JP)
• **Tadafumi, Ozaki**
Gifu-shi,Gifu-ken 502-0905 (JP)

(30) Priority: **24.11.2004 JP 2004339682**

(74) Representative: **Grünecker, Kinkeldey, Stockmair & Schwanhäusser**
Anwaltssozietät
Leopoldstrasse 4
80802 München (DE)

(71) Applicant: **SEMICONDUCTOR ENERGY LABORATORY CO., LTD.**
Atsugi-shi, Kanagawa-ken 243-0036 (JP)

(54) **Active matrix OLED display device and electronic apparatus**

(57) The invention provides a display device and an electronic apparatus which can reduce power consumption in the case of being driven by using a digital time grayscale method. According to the invention, a row in which all the pixels display black is focused on in a plurality of pixels arranged in matrix, and sampling of data which is to be inputted to the pixels arranged in the row is not performed. Then, in a period during which the data

sampling is not performed, the operation of a shift register in a source driver and sampling operation of a video signal in a first latch circuit are stopped. The invention which has the aforementioned characteristics can temporarily stop operation of the source driver to reduce power consumption. In particular, the invention can stop operation of the source driver which consumes much power in the display device, leading to dramatic reduction in power consumption.

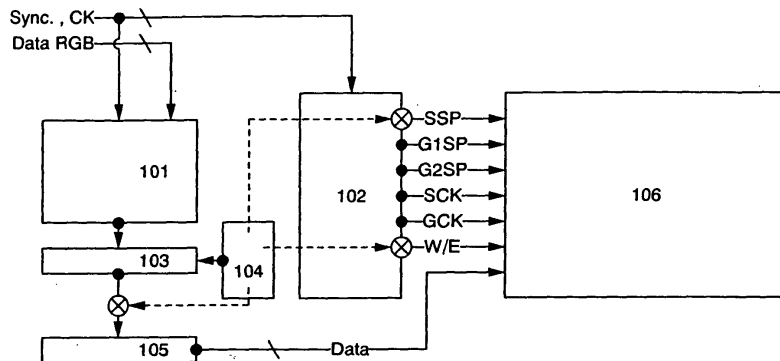

FIG. 1

EP 1 662 468 A3



DOCUMENTS CONSIDERED TO BE RELEVANT			
Category	Citation of document with indication, where appropriate, of relevant passages	Relevant to claim	CLASSIFICATION OF THE APPLICATION (IPC)
X	US 2003/197472 A1 (KANAUCHI KATSUHIRO [JP] ET AL) 23 October 2003 (2003-10-23)	1,3-9, 11-17, 19-25, 27-33, 35-40	INV. G09G3/32
Y	* paragraph [0002] - paragraph [0005] * * paragraph [0015] - paragraph [0019] * * paragraph [0055] - paragraph [0063]; figures 3-9 * * paragraph [0067] - paragraph [0084]; figures 10-15 *	2,10,18, 26,34	
D,Y	JP 2001 324958 A (SEMICONDUCTOR ENERGY LAB) 22 November 2001 (2001-11-22) * the whole document *	2,10,18, 26,34	
X	US 2002/135556 A1 (NAKAJIMA YOSHIHARU [JP] ET AL) 26 September 2002 (2002-09-26) * paragraph [0057] - paragraph [0073]; figures 3,4 * * paragraph [0085] - paragraph [0099]; figure 5 * * paragraph [0142] - paragraph [0143] *	1,9,17, 25,33	TECHNICAL FIELDS SEARCHED (IPC) G09G
Y	EP 0 852 371 A (HITACHI LTD [JP]) 8 July 1998 (1998-07-08) * page 3, column 4, line 20 - page 4, column 5, line 39; figures 1-3 * * page 5, column 8, line 16 - line 32; figure 6 *	1-40	
Y	US 2004/140972 A1 (HIROTA SHOUICHI [JP] ET AL) 22 July 2004 (2004-07-22) * paragraph [0062] - paragraph [0077]; figures 2-4 *	1-40	
		----- -/--	
The present search report has been drawn up for all claims			
Place of search Munich		Date of completion of the search 20 August 2008	Examiner Morris, David
CATEGORY OF CITED DOCUMENTS X : particularly relevant if taken alone Y : particularly relevant if combined with another document of the same category A : technological background O : non-written disclosure P : intermediate document		T : theory or principle underlying the invention E : earlier patent document, but published on, or after the filing date D : document cited in the application L : document cited for other reasons & : member of the same patent family, corresponding document	



DOCUMENTS CONSIDERED TO BE RELEVANT			
Category	Citation of document with indication, where appropriate, of relevant passages	Relevant to claim	CLASSIFICATION OF THE APPLICATION (IPC)
D,A	JP 2001 005426 A (SEMICONDUCTOR ENERGY LAB) 12 January 2001 (2001-01-12) * the whole document * -----	1-40	
			TECHNICAL FIELDS SEARCHED (IPC)
The present search report has been drawn up for all claims			
Place of search Munich		Date of completion of the search 20 August 2008	Examiner Morris, David
CATEGORY OF CITED DOCUMENTS X : particularly relevant if taken alone Y : particularly relevant if combined with another document of the same category A : technological background O : non-written disclosure P : intermediate document		T : theory or principle underlying the invention E : earlier patent document, but published on, or after the filing date D : document cited in the application L : document cited for other reasons & : member of the same patent family, corresponding document	

EPO FORM 1503 03/02 (P04C01) 2

ANNEX TO THE EUROPEAN SEARCH REPORT
ON EUROPEAN PATENT APPLICATION NO.

EP 05 02 5577

This annex lists the patent family members relating to the patent documents cited in the above-mentioned European search report. The members are as contained in the European Patent Office EDP file on
The European Patent Office is in no way liable for these particulars which are merely given for the purpose of information.

20-08-2008

Patent document cited in search report	Publication date	Patent family member(s)	Publication date
US 2003197472 A1	23-10-2003	CN 1453761 A	05-11-2003
		JP 2003316315 A	07-11-2003
		TW 228695 B	01-03-2005

JP 2001324958 A	22-11-2001	NONE	

US 2002135556 A1	26-09-2002	CN 1383536 A	04-12-2002
		EP 1211662 A1	05-06-2002
		WO 0178051 A1	18-10-2001
		JP 2001290460 A	19-10-2001
		NO 20015907 A	31-01-2002
		TW 223226 B	01-11-2004

EP 0852371 A	08-07-1998	WO 9711447 A1	27-03-1997
		JP 3694527 B2	14-09-2005
		US 6329973 B1	11-12-2001

US 2004140972 A1	22-07-2004	NONE	

JP 2001005426 A	12-01-2001	CN 1279519 A	10-01-2001
		EP 1063630 A2	27-12-2000
		KR 20010021025 A	15-03-2001
		TW 457729 B	01-10-2001
		US 6774574 B1	10-08-2004

专利名称(译)	有源矩阵OLED显示装置和电子设备		
公开(公告)号	EP1662468A3	公开(公告)日	2008-10-01
申请号	EP2005025577	申请日	2005-11-23
[标]申请(专利权)人(译)	株式会社半导体能源研究所		
申请(专利权)人(译)	半导体能源研究所有限公司.		
当前申请(专利权)人(译)	半导体能源研究所有限公司.		
[标]发明人	TADAFUMI OZAKI		
发明人	YOSHIFUMI, TANADA SEMICONDUCTOR ENERGY LAB.CO.LTD. TADAFUMI, OZAKI		
IPC分类号	G09G3/32		
CPC分类号	G09G3/2022 G09G3/2092 G09G3/3225 G09G3/3266 G09G3/3275 G09G2300/08 G09G2300/0809 G09G2310/063 G09G2320/041 G09G2330/021 G09G2330/022 G09G2360/18		
优先权	2004339682 2004-11-24 JP		
其他公开文献	EP1662468B1 EP1662468A2		
外部链接	Espacenet		

摘要(译)

本发明提供一种显示装置和电子设备，其能够在使用数字时间灰度级方法驱动的情况下降低功耗。根据本发明，其中所有像素显示为黑色的行聚焦在以矩阵排列的多个像素中，并且不执行要输入到排列在行中的像素的数据的采样。然后，在不执行数据采样的时段中，停止源极驱动器中的移位寄存器的操作和第一锁存电路中的视频信号的采样操作。具有上述特征的本发明可暂时停止源极驱动器的操作以降低功耗。特别地，本发明可以停止在显示装置中消耗大量功率的源极驱动器的操作，从而导致功耗的显著降低。

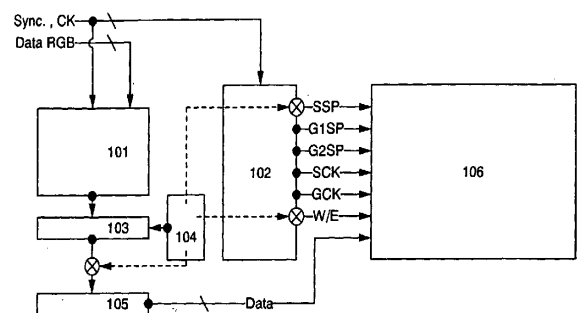

FIG. 1