

(19) World Intellectual Property Organization
International Bureau



(43) International Publication Date
3 January 2008 (03.01.2008)

PCT

(10) International Publication Number
WO 2008/000750 A1

- (51) International Patent Classification:
G09G 3/32 (2006.01)
- (21) International Application Number:
PCT/EP2007/056385
- (22) International Filing Date: 26 June 2007 (26.06.2007)
- (25) Filing Language: English
- (26) Publication Language: English
- (30) Priority Data:
06300737.1 30 June 2006 (30.06.2006) EP
- (71) Applicant (for all designated States except US): **THOMSON LICENSING** [FR/FR]; 46 Quai A. Le Gallo, F-92100 Boulogne-Billancourt (FR).
- (72) Inventors; and
- (75) Inventors/Applicants (for US only): **WEITBRUCH, Sébastien** [FR/DE]; Im Wolfacker 25, 78078 Kappel (DE). **DOSER, Ingo** [DE/DE]; Lehenstrasse 21, 78166

Donaueschingen (DE). **THIEBAUD, Sylvain** [FR/FR]; 11 rue de la Janaie, F-35530 Noyal Sur Vilaine (FR).

(74) Agents: **LE DANTEC, Claude** et al.; Thomson, 46, Quai Alphonse Le Gallo, F-92100 Boulogne Billancourt (FR).

(81) Designated States (unless otherwise indicated, for every kind of national protection available): AE, AG, AL, AM, AT, AU, AZ, BA, BB, BG, BH, BR, BW, BY, BZ, CA, CH, CN, CO, CR, CU, CZ, DE, DK, DM, DO, DZ, EC, EE, EG, ES, FI, GB, GD, GE, GH, GM, GT, HN, HR, HU, ID, IL, IN, IS, JP, KE, KG, KM, KN, KP, KR, KZ, LA, LC, LK, LR, LS, LT, LU, LY, MA, MD, ME, MG, MK, MN, MW, MX, MY, MZ, NA, NG, NI, NO, NZ, OM, PG, PH, PL, PT, RO, RS, RU, SC, SD, SE, SG, SK, SL, SM, SV, SY, TJ, TM, TN, TR, TT, TZ, UA, UG, US, UZ, VC, VN, ZA, ZM, ZW.

(84) Designated States (unless otherwise indicated, for every kind of regional protection available): ARIPO (BW, GH, GM, KE, LS, MW, MZ, NA, SD, SL, SZ, TZ, UG, ZM, ZW), Eurasian (AM, AZ, BY, KG, KZ, MD, RU, TJ, TM), European (AT, BE, BG, CH, CY, CZ, DE, DK, EE, ES, FI,

[Continued on next page]

(54) Title: ACTIVE MATRIX ORGANIC LIGHT EMITTING DISPLAY (AMOLED) DEVICE

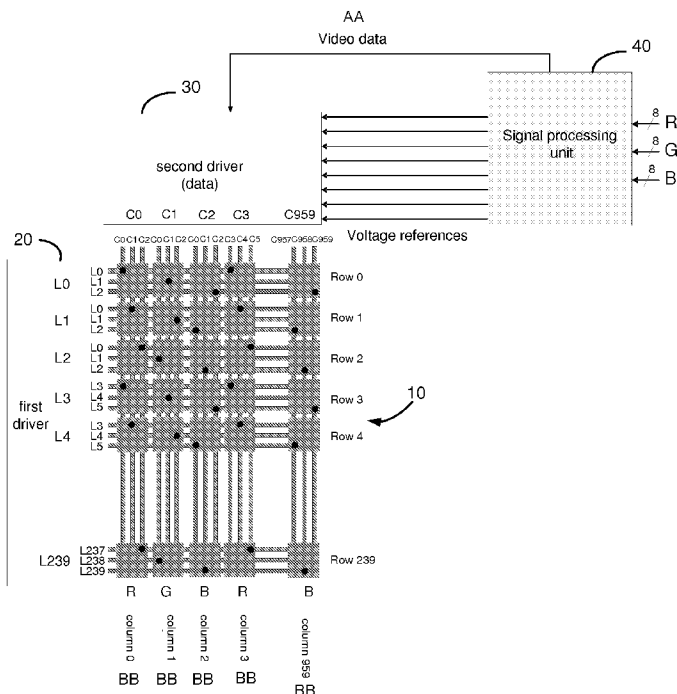

(57) Abstract: The present invention relates to an active matrix OLED (Organic Light Emitting Display) device. It comprises a matrix of luminous elements associated to different colour components (red, green, blue). According to the invention, the connection of the row driver (20) and/or data driver (30) to the luminous elements of the matrix is modified. Each output of the row driver is connected to luminous element associated to a same colour component (red or green or blue).

- AA données vidéo
- 30 second dispositif d'attaque (donnée)
- 40 unité de traitement de signal
références de tension
- 20 premier dispositif d'attaque
- 10 rang 0, 1, 2, ...
- BB colone 0, 1, 2.....

WO 2008/000750 A1



FR, GB, GR, HU, IE, IS, IT, LT, LU, LV, MC, MT, NL, PL,
PT, RO, SE, SI, SK, TR), OAPI (BF, BJ, CF, CG, CI, CM,
GA, GN, GQ, GW, ML, MR, NE, SN, TD, TG).

For two-letter codes and other abbreviations, refer to the "Guidance Notes on Codes and Abbreviations" appearing at the beginning of each regular issue of the PCT Gazette.

Published:

— *with international search report*

ACTIVE MATRIX ORGANIC LIGHT EMITTING DISPLAY (AMOLED) DEVICE

Field of the invention

- 5 The present invention relates to an active matrix OLED (Organic Light Emitting Display) device. This device has been more particularly but not exclusively developed for video application.

Background of the invention

- 10 The structure of an active matrix OLED or AM-OLED is well known. It comprises:
- an active matrix containing, for each cell, an association of several thin film transistors (TFT) with a capacitor connected to an OLED material; the capacitor acts as a memory component that stores a value during a part of
 - 15 the video frame, this value being representative of a video information to be displayed by the cell during the next video frame or the next part of the video frame; the TFTs act as switches enabling the selection of the cell, the storage of a data in the capacitor and the displaying by the cell of a video information corresponding to the stored data;
 - 20 - a row or gate driver that selects line by line the cells of the matrix in order to refresh their content;
 - a column or source driver that delivers the data to be stored in each cell of the current selected line; this component receives the video information for each cell; and
 - 25 - a digital processing unit that applies required video and signal processing steps and that delivers the required control signals to the row and column drivers.

30 Actually, there are two ways for driving the OLED cells. In a first way, each piece of digital video information sent by the digital processing unit is converted by the column drivers into a current whose amplitude is

proportional to the video information. This current is provided to the appropriate cell of the matrix. In a second way, the digital video information sent by the digital processing unit is converted by the column drivers into a voltage whose amplitude is proportional to the video information. This
5 current or voltage is provided to the appropriate cell of the matrix.

From the above, it can be deduced that the row driver has a quite simple function since it only has to apply a selection line by line. It is more or less a shift register. The column driver represents the real active part and can be
10 considered as a high level digital to analog converter. The displaying of video information with such a structure of AM-OLED is the following one. The input signal is forwarded to the digital processing unit that delivers, after internal processing, a timing signal for row selection to the row driver synchronized with the data sent to the column drivers. The data transmitted
15 to the column driver are either parallel or serial. Additionally, the column driver disposes of a reference signalling delivered by a separate reference signalling device. This component delivers a set of reference voltages in case of voltage driven circuitry or a set of reference currents in case of current driven circuitry. The highest reference is used for the white and the
20 lowest for the black level. Then, the column driver applies to the matrix cells the voltage or current amplitude corresponding to the data to be displayed by the cells.

In order to illustrate this concept, an example of a voltage driven circuitry is
25 described below. Such a circuitry will also be used in the rest of the present specification for illustrating the invention. The driver taken as example uses 8 reference voltages named V_0 to V_7 and the video levels are built as shown below:

Video level	Grayscale voltage level	Output voltage
0	V7	0.00V
1	$V7+(V6-V7) \times 9/1175$	0.001V
2	$V7+(V6-V7) \times 32/1175$	0.005V
3	$V7+(V6-V7) \times 76/1175$	0.011V
4	$V7+(V6-V7) \times 141/1175$	0.02V
5	$V7+(V6-V7) \times 224/1175$	0.032V
6	$V7+(V6-V7) \times 321/1175$	0.045V
7	$V7+(V6-V7) \times 425/1175$	0.06V
8	$V7+(V6-V7) \times 529/1175$	0.074V
9	$V7+(V6-V7) \times 630/1175$	0.089V
10	$V7+(V6-V7) \times 727/1175$	0.102V
11	$V7+(V6-V7) \times 820/1175$	0.115V
12	$V7+(V6-V7) \times 910/1175$	0.128V
13	$V7+(V6-V7) \times 998/1175$	0.14V
14	$V7+(V6-V7) \times 1086/1175$	0.153V
15	V6	0.165V
16	$V6+(V5-V6) \times 89/1097$	0.176V
17	$V6+(V5-V6) \times 173/1097$	0.187V
18	$V6+(V5-V6) \times 250/1097$	0.196V
19	$V6+(V5-V6) \times 320/1097$	0.205V
20	$V6+(V5-V6) \times 386/1097$	0.213V
21	$V6+(V5-V6) \times 451/1097$	0.221V
22	$V6+(V5-V6) \times 517/1097$	0.229V
...
250	$V1+(V0-V1) \times 2278/3029$	2.901V
251	$V1+(V0-V1) \times 2411/3029$	2.919V
252	$V1+(V0-V1) \times 2549/3029$	2.937V
253	$V1+(V0-V1) \times 2694/3029$	2.956V
254	$V1+(V0-V1) \times 2851/3029$	2.977V
255	V0	3.00V

A more complete table is given in Annex 1. This table illustrates the output voltage for various input video levels. The reference voltages used are for example the following ones:

Reference V_n	Voltage (Volts)
V0	3
V1	2.6
V2	2.2
V3	1.4
V4	0.6
V5	0.3
V6	0.16
V7	0

Actually, there are three ways for making colour displays:

- 5 - a first possibility illustrated by figure 1 is to use a white OLED emitter having on top photopatternable colour filters; this type of display is similar to the current LCD displays where the colour is also done by using colour filters; it has the advantage of using one single OLED material deposition and of having a good colour tuning possibility but the efficiency of the whole display is limited by the colour filters.
- 10 - a second possibility illustrated by figure 2 is to use blue OLED emitters having on top photopatternable colour converters for red and green; such converters are mainly based on materials that absorb a certain spectrum of light and convert it to an other spectrum that is always lower; this type of display has the advantage of using one single OLED material deposition but the efficiency of the whole display is limited by the colour converters; 15 furthermore, blue materials are needed since the spectrum of the light can only be reduced by the converters but the blue materials are always the less efficient both in terms of light emission and lifetime.
- 20 - a third possibility illustrated by figure 3 is to use different OLED emitters for the 3 colours red, green and blue. This type of display requires at least 3 material deposition steps but the emitters are more efficient since not filtered.

The invention is more particularly adapted to the displays of figure 3. It can be also used for the other types of display.

The use of three different OLED materials (one par colour) implies that they all have different behaviours. This means that they all have different threshold voltages and different efficiencies as illustrated by figure 4. In the example of figure 4, the threshold voltage $V_{B_{th}}$ of the blue material is greater than the threshold voltage $V_{G_{th}}$ of the green material that is itself greater than the threshold voltage $V_{R_{th}}$ of the red material. Moreover, the efficiency of the green material is greater than the efficiencies of the red and blue materials. Consequently, in order to achieve a given colour temperature, the gain between these 3 colours must be further adjusted depending on the material colour coordinates in the space. For instance, the following materials are used:

Red ($x=0.64;y=0.33$) with 6 cd/A and $V_{R_{th}} = 3V$

Green ($x=0.3;y=0.6$) with 20 cd/A and $V_{G_{th}} = 3.3V$

Blue ($x=0.15;y=0.11$) with 4 cd/A and $V_{B_{th}} = 3.5V$

15

Thus a white colour temperature of $6400^{\circ}K$ ($x=0.313;y=0.328$) is achieved by using 100% of the red, 84% of the green and 95% of the blue.

If one driver with only one set of reference signals (voltages or currents) for the 3 colours is used and if the maximum voltage to be applied to the cells is 7 Volts ($=V_{max}$), the voltage range must be from 3V to 7V but only a part of this dynamic can be used and all corrections must be done digitally. Such a correction will reduce the video dynamic of the whole display. Figure 5 illustrates the final used video dynamic for the 3 colours. More particularly, the figure 5 shows the range used for each diode (colour material) in order to have proper colour temperature and black level. Indeed, the minimum voltage V_{min} ($= V7$ in the previous table) to be applied to the diodes must be chosen equal to 3V to enable switching OFF the red diode and the lowest lighting voltage ($=V7+(V6-V7)x9/1175$ in the previous table) must be chosen according the blue threshold level to adjust black level. The maximum voltage to be chosen for each diode is adapted to the white colour

20
25
30

temperature that means 100% red, 84% green and 95% blue. Finally, it can be seen that only a very small part of the green video range is used.

5 Since the video levels between 3V and 7V are defined with 256 bits, it means that the green component is displayed with only a few digital levels. The red component uses a bit more gray level but this is still not enough to provide a satisfying picture quality.

10 A solution is disclosed in the European patent application 05292435.4 filed in the name of Deutsche Thomson-Brandt GmbH. In this application, a different reference signalling is used to display each of the three colour components. In this solution, the luminous elements are addressed in a way different from the standard addressing.

15 Figure 6 illustrates the standard addressing of video data in an AMOLED display. The matrix of luminous elements comprises for example 320x3=960 columns (320 columns per colour) C0 to C959 and 240 rows L0 to L239 like a QVGA display (320x240 pixels). For the sake of simplicity, only 5 rows L0 to L4 and 5 columns C0 to C3 and C959 are shown in this figure. C0 is a
20 column of red luminous elements, C1 is a column of green luminous elements, C2 is a column of blue luminous elements, C3 is a column of red luminous elements and so on. Each output of the row driver is connected to a row of luminous elements of the matrix. The video data that must be addressed to the luminous element belonging to the column C_i and the row
25 L_j is expressed by $X(i,j)$ wherein X designates one of the colour components R, G, B. The video data of the picture to be displayed are processed by a signal processing unit that delivers the video data $R(0,0)$, $G(1,0)$, $B(2,0)$, $R(3,0)$, $G(4,0)$, $B(5,0)$, ... $R(957,0)$, $G(958,0)$, $B(959,0)$ for the row of luminous elements L0 and the reference voltages to be used for displaying
30 said video data to a data driver (or column driver) having 960 outputs, each output being connected to a column of the matrix. The same set of reference

voltages is used for all the video data. Consequently, to display colours, this standard addressing requires an adjustment of the reference voltages combined with a video adjustment of the three colours but these adjustments does not prevent from having a large loss of the video dynamic as shown in
5 Figure 5.

The solution presented in the above-mentioned European patent application 05292435.4 is a specific addressing that can be used in a standard active matrix OLED. The idea is to have a set of reference voltages (or currents) for
10 each colour and to address three times per frame the luminous elements of the display such that the video frame is divided into three sub-frames, each sub-frame being adapted to display mainly a dedicated colour by using the corresponding set of reference voltages. The main colour to be displayed as and the set of reference voltages change at each sub-frame.

15

For example, the red colour is displayed during the first sub-frame with the set of reference voltages dedicated to the red colour, the green colour is displayed during the second sub-frame with the set of reference voltages dedicated to the green colour and the blue colour is displayed during the
20 third sub-frame with the set of reference voltages dedicated to the blue colour.

A little bit different solution is explained in more detail in reference to figure 7 that illustrates a possible embodiment. During the first sub-frame, the three
25 components are displayed using the reference voltages adapted to the green component to dispose of a full grayscale dynamic for this component. $\{V0(G), V1(G), V2(G), V3(G), V4(G), V5(G), V6(G), V7(G)\}$ designates the set of reference voltages dedicated to the green component. The two other components are only partially displayed. So the sub-picture displayed during
30 this sub-frame is greenish/yellowish. During the second sub-frame, the green component is deactivated (set to zero) and the voltages are adapted to

dispose of a full dynamic for the red component by using the set of reference voltages dedicated to the red component $\{V0(R), V1(R), V2(R), V3(R), V4(R), V5(R), V6(R), V7(R)\}$. The sub-picture displayed during this sub-frame is purplish. Finally during the third sub-frame, the green and red components are deactivated (set to zero) and the voltages are adapted to dispose of a full dynamic for the blue component by using the set of reference voltages dedicated to the blue component $\{V0(B), V1(B), V2(B), V3(B), V4(B), V5(B), V6(B), V7(B)\}$.

- 10 It is thus possible to adjust the 8 reference voltages (or currents) at each sub-frame. The only particularity is that the lowest reference voltages must be kept equal to the lowest threshold voltage of the three colours. Indeed, displaying a blue component means having red and green components equal to zero, which means equal to $V7$ that is the lowest reference voltage.
- 15 So, this voltage must be low enough to have them really black. In the example of Figure 5, we must have

$$V7(R) = V7(B) = V7(G) = V_{R_{th}}.$$

The only additional requirement is the necessity of addressing the matrix three times faster.

20

Figures 8 to 10 illustrates the functioning of the display device during the three sub-frames. In reference to figure 8, during the first sub-frame, the video data of the picture to be displayed are converted into voltages to be applied to the luminous elements of the matrix by the data driver that uses the set of reference voltages dedicated to the green component. The set of reference voltages are distributed between 3 volts ($=V7(G)=V_{R_{th}}$) and about 4 volts $=V0(G)$ that is the maximum voltage that can be used for displaying the green component.

An example of reference voltages for the green component is given below:

Reference V_n	Voltage (Volts)
V0	4
V1	3.85
V2	3.75
V3	3.45
V4	3.2
V5	3.1
V6	3.05
V7	3

In reference to figure 9, during the second sub-frame, the video data of the picture to be displayed are converted into voltages to be applied to the luminous elements of the matrix by the data driver that uses the set of reference voltages dedicated to the red component. The video data corresponding to the green and red components are set to zero. The set of reference voltages are distributed between 3 volts ($=V7(R)=V_{R_{th}}$) and about 5,4 volts $=V0(R)$ that is the maximum voltage that can be used for displaying the red component.

10 An example of reference voltages for the red component is given below:

Reference V_n	Voltage (Volts)
V0	5.4
V1	5.08
V2	4.76
V3	4.12
V4	3.48
V5	3.24
V6	3.13
V7	3

In reference to figure 10, during the third sub-frame, the video data of the picture to be displayed are converted into voltages to be applied to the luminous elements of the matrix by the data driver that uses the set of reference voltages dedicated to the blue component. The video data corresponding to the green component are set to zero. The set of reference voltages are distributed between 3 volts ($=V7(G)=V_{R_{th}}$) and about 7 volts $=V0(B)$ that is the maximum voltage that can be used for displaying the blue component.

An example of reference voltages for the blue component is given below:

Reference V_n	Voltage (Volts)
V0	7
V1	6.46
V2	5.93
V3	4.86
V4	3.8
V5	3.4
V6	3.21
V7	3

In a more general manner, the colour component having the highest luminosity capabilities (in the present case, the green component) is displayed only in the first sub-frame. The colour component having the lowest luminosity capabilities (in the present case, the blue component) is displayed in the three sub-frames and the colour component having in-between luminosity capabilities (in the present case, the red component) is displayed during two sub-frames.

10

A drawback of this solution is that it requires addressing the matrix three times faster than a standard addressing. Another drawback is that there is some colour lag on moving edges since different colours are displayed at different time periods (for example Red+Green+Blue during the first sub-frame, Red+Blue during the second sub-frame and .only blue during the third sub-frame)

15

Summary of the invention

It is an object of the present invention to propose a solution to reduce one or more of these drawbacks. According to the invention, new AMOLED matrix structures are proposed and these new structures can be used to have different sets of reference voltages (or currents) for different colour components.

20

25 This object is solved by a display device comprising

- an active matrix containing an array of luminous elements arranged in n rows and m columns, each luminous element being associated to a colour component among k different colour components of a picture to be displayed, k being greater than 1 and the luminous elements being arranged in groups of k consecutive luminous elements associated to different colour components,
- 5 - a first driver having p outputs connected to the active matrix for selecting luminous elements of the matrix; each output of the first driver being connected to a different part of the matrix and the parts of the matrix being selected by the first driver one after the other,
- 10 - a second driver having q outputs connected to the active matrix for delivering a signal to each luminous element selected by the first driver, said signal depending on the video information to be displayed by the selected luminous elements; and
- 15 - a digital processing unit for delivering video information to the second driver and control signals to the first driver.

According to the invention, each output of the first driver is connected to luminous elements associated to a same colour component, the signal of the video information to be displayed by each of the luminous elements connected to an output of the first driver being delivered by a separate output of the second driver.

Thus, as the different parts of the matrix are selected one after the other and as each part of the matrix is associated to a same colour component (all the luminous elements of a part of the matrix are connected to the same output of the first driver), a set of reference voltages (or currents) associated to this colour component can be selected when said part of matrix is selected.

Several embodiments are possible depending on whether the k luminous elements of each group belong to one and the same row or to one and the

same column of luminous elements of the matrix. Several embodiments are also possible depending on the number of outputs of the first and second driver.

5 In a first embodiment, the k luminous elements of each group belong to one and the same row, the first driver has $p=n$ outputs, the second driver has $q=m$ outputs and each output of the first driver is connected to all luminous elements associated to a same colour component and belonging to k rows of luminous elements of the active matrix.

10

In a second embodiment, the k luminous elements of each group belong to one and the same row, the first driver has $p=k*n$ outputs, the second driver has $q=m/k$ outputs and each output of the first driver is connected to all luminous elements associated to a same colour component and belonging to
15 a same row of luminous elements of the matrix. Each output of the second driver is connected to the k luminous elements of a same group of luminous elements. In this embodiment, two consecutive outputs of the first driver are connected to luminous elements associated to different colour components.

20 In a third embodiment which is a variant of the second embodiment, at least two consecutive outputs of the first driver are connected to luminous elements associated to a same colour component.

In a fourth embodiment, the k luminous elements of each group belong to
25 one and the same column of luminous elements of the active matrix, the first driver has $p=n/k$ outputs and the second driver has $q=m*k$ outputs. k outputs of the second driver are connected to luminous elements of a same column, each one of said k outputs being connected to luminous elements associated to a same colour component and each output of the first driver is
30 connected to all luminous elements associated to a same colour component

and belonging to a same column of luminous elements and to k rows of luminous elements of the active matrix.

In all these embodiments, the video information delivered to the second driver is based on sets of reference signals, a different set of reference signals being associated to at least two different colour components. The digital processing unit controls the first driver and delivers video information and reference signals to the second driver such that, each time the luminous elements connected to an output of the first driver are selected, the digital processing unit delivers to the second driver the video information of the luminous elements selected by the first driver and the set of reference signals associated to the colour component of these selected luminous elements.

15 Brief description of the drawings

Exemplary embodiments of the invention are illustrated in the drawings and are explained in more detail in the following description. In the drawings:

- 20 Fig.1 shows a white OLED emitter having 3 colour filters for generating the red, green and blue colours;
- Fig.2 shows a blue OLED emitter having 2 colour converters for generating the red, green and blue colours;
- Fig.3 shows a red OLED emitter, a green OLED emitter and a blue OLED emitter for generating the red, green and blue colours;
- 25 Fig.4 is a schematic diagram illustrating the threshold voltages and the efficiencies of blue, green and red OLED materials;
- Fig.5 shows the video range used for each blue, green and red OLED material of figure 4;
- 30 Fig.6 illustrates the standard addressing of video data in an AMOLED display;

- Fig.7 illustrates the addressing of video data in an AMOLED display in prior art;
- Fig.8 illustrates the addressing of video data in an AMOLED display during a first sub-frame of the video frame in accordance with Fig.7;
- 5 Fig.9 illustrates the addressing of video data in an AMOLED display during a second sub-frame of the video frame in accordance with Fig.7;
- Fig.10 illustrates the addressing of video data in an AMOLED display during a third sub-frame of the video frame in accordance with Fig.7;
- 10 Fig.11 illustrates the connection of the first driver (row driver) and the second driver (data driver) to the active matrix according to the invention;
- Fig.12 shows a layout for a part of 3x3 luminous elements of the active matrix of Fig.11;
- Fig.13 illustrates the addressing of video data in the display device of figure 11 when the output L0 of the first driver is activated;
- Fig.14 illustrates the addressing of video data in the display device of figure 11 when the output L1 of the first driver is activated;
- 20 Fig.15 illustrates the addressing of video data in the display device of figure 11 when the output L2 of the first driver is activated;
- Fig.16 illustrates the addressing of video data in the display device of figure 11 when the output L3 of the first driver is activated;
- 25 Fig.17 shows a layout for 4 parts of 3x3 luminous elements of the active matrix;
- Fig.18 illustrates a first variant of figure 11;
- Fig.19 illustrates a second variant of figure 11; and
- Fig.20 illustrates a third variant of figure 11.

30

DESCRIPTION OF PREFERRED EMBODIMENTS

The idea of the invention is to address at one given time period of the video frame only the luminous elements associated to one colour component by amending the connection of the row driver and the column driver to the active matrix and by addressing differently the video information to the column driver. In the following specification, the row driver is called first driver because a same output of this driver can select luminous elements belonging to a group of rows and the column driver is called second driver because two outputs of this driver can deliver simultaneously video information to luminous elements belonging to a same column of the matrix. The internal structure of the first and second drivers is identical to the one of classical row and column drivers and is well known from the man skilled in the art.

Figure 11 shows a display device comprising a QVGA matrix 10 of luminous elements arranged in 240 rows and 320x3 columns, a first driver 20 comprising 240 outputs L0 to L239 for selecting luminous elements of the matrix, a second driver 30 comprising 960 (=320x3) outputs C0 to C959 connected to the luminous elements of the matrix and a video processing unit 40 for delivering video information and a set of reference voltages to the second driver. The first column of the matrix comprises only red luminous elements, the second column comprises only green luminous elements, the third column comprises only blue luminous elements, the fourth column comprises only red luminous elements and so on. A first way of connecting the outputs L0 to L239 of the driver 20 and the outputs C0 to C959 of the driver 30 to the luminous elements of the matrix 10 is illustrated by Figure 11. The connection of a luminous element to an output Ci of the second driver and an output Lj of the first driver is shown by a black point placed at the intersection of a column line connected to the output Ci and a row line connected to the output Lj. For example, the driver outputs C0 and L0 are connected to the first luminous element of the first row of the matrix, the

driver outputs C1 and L1 are connected to the second luminous element of the first row of the matrix and the driver outputs C2 and L2 are connected to the third luminous element of the first row of the matrix. In this figure, 3 row lines are connected to each output L_j of the driver 20 and 3 column lines are connected to each output C_i of the driver 30 and all these lines are rectilinear and go throughout the matrix of cells.

Figure 12 shows in more detail an example for connecting the driver outputs L0 to L2 and C0 to C2 to the first 3x3 luminous elements of the matrix. In this figure, each luminous element comprises an arrangement of two transistors T1 and T2, a capacitor and an organic light emitting diode (OLED). This arrangement is well known from the man skilled in the art. In a more general way, the driver output L0 is connected to all the red luminous elements of the three first rows of the matrix, the driver output L1 is connected to all the green luminous elements of the three first rows of the matrix and the driver output L2 is connected to all the blue luminous elements of the three first rows of the matrix. A separate output of the driver 30 is connected to each red luminous element of the three first rows of the matrix. The output C0 is connected to the first red luminous element of the first row of the matrix, the output C1 is connected to the first red luminous element of the second row of the matrix and the output C2 is connected to the first red luminous element of the third row of the matrix. For the green component, the output C1 is connected to the first green luminous element of the first row of the matrix, the output C2 is connected to the first green luminous element of the second row of the matrix and the output C0 is connected to the first green luminous element of the third row of the matrix. For the blue component, the output C2 is connected to the first blue luminous element of the first row of the matrix, the output C0 is connected to the first blue luminous element of the second row of the matrix and the output C1 is connected to the first blue luminous element of the third row of the matrix.

Figures 13 to 16 illustrate the functioning of the display device according to the invention. When displaying a picture, the driver 20 activates sequentially its outputs L_j . Figure 13 shows the video information sent to the second driver 30 when the outputs L_0 of the driver 20 is activated (ON). The red luminous elements of the three first rows (rows numbered 0, 1 and 2) of the matrix are thus selected. The video information $R(0,0)$, $R(0,1)$, $R(0,2)$, $R(3,0)$, $R(3,1)$, $R(3,2)$... $R(957,2)$ is sent to the driver 30. $R(i,j)$ designates the piece of video information dedicated to the red luminous element belonging to the column i and the row j of the matrix. As only red luminous elements are selected when the output L_0 is activated, the set of voltage references dedicated to the red component $\{V_0(R), V_1(R), V_2(R), V_3(R), V_4(R), V_5(R), V_6(R), V_7(R)\}$ is sent also to the second driver 30. The video information is converted into voltages by the driver 30 and these voltages are applied to the selected luminous elements. The graph at the bottom-right corner of figure 13 shows the used diode dynamic when the output L_0 is selected and when the set of reference voltages are distributed between 3 volts ($=V_7(R)=V_{R_{th}}$) and about 5,4 volts $=V_0(R)$ that is the maximum voltage that can be used for displaying the red component. The example of reference voltages given above in a table for the red component can be used.

Figure 14 shows the video information sent to the second driver 30 when the outputs L_1 of the driver 20 is activated (ON). The green luminous elements of the three first rows of the matrix are thus selected. The video information $G(1,0)$, $G(1,1)$, $G(1,2)$, $G(4,0)$, $G(4,1)$, $G(4,2)$... $G(958,2)$ is sent to the driver 30. $G(i,j)$ designates the piece of video information dedicated to the green luminous element belonging to the column i and the row j of the matrix. As only green luminous elements are selected when the output L_1 is activated, the set of voltage references dedicated to the green component $\{V_0(G), V_1(G), V_2(G), V_3(G), V_4(G), V_5(G), V_6(G), V_7(G)\}$ is sent also to the second driver 30. The video information is converted into voltages by the

driver 30 and these voltages are applied to the selected luminous elements. The graph at the bottom-right corner of figure 14 shows the used diode dynamic when the output L1 is selected and when the set of reference voltages are distributed between 3 volts ($=V7(G)=VR_{th}$) and about 4 volts
5 $=V0(G)$ that is the maximum voltage that can be used for displaying the green component. The example of reference voltages given above in a table for the green component can be used.

Figure 15 shows the video information sent to the second driver 30 when the
10 outputs L2 of the driver 20 is activated (ON). The blue luminous elements of the three first rows of the matrix are thus selected. The video information $B(2,0)$, $B(2,1)$ $B(2,2)$, $B(5,0)$, $B(5,1)$ $B(5,2)$... $B(959,2)$ is sent to the driver 30. $B(i,j)$ designates the piece of video information dedicated to the blue luminous element belonging to the column i and the row j of the matrix. As
15 only blue luminous elements are selected when the output L2 is activated, the set of voltage references dedicated to the blue component $\{V0(B),V1(B),V2(B),V3(B),V4(B),V5(B),V6(B),V7(B)\}$ is sent also to the second driver 30. The video information is converted into voltages by the driver 30 and these voltages are applied to the selected luminous elements.
20 The graph at the bottom-right corner of figure 15 shows the used diode dynamic when the output L2 is selected and when the set of reference voltages are distributed between 3 volts ($=V7(B)=VR_{th}$) and about 7 volts $=V0(B)$ that is the maximum voltage that can be used for displaying the green component. The example of reference voltages given above in a table
25 for the blue component can be used.

Figure 16 shows the video information sent to the second driver 30 when the
outputs L3 of the driver 20 is activated (ON). The red luminous elements of the fourth, fifth and sixth rows (rows numbered 3, 4 and 5) of the matrix are
30 thus selected. The video information $R(0,3)$, $R(0,4)$ $R(0,5)$, $R(3,3)$, $R(3,4)$ $R(3,5)$... $R(957,5)$ is sent to the driver 30. As previously mentioned, $R(i,j)$

designates the piece of video information dedicated to the red luminous element belonging to the column i and the row j of the matrix. As only red luminous elements are selected when the output L3 is activated, the set of voltage references dedicated to the red component

5 {V0(R),V1(R),V2(R),V3(R),V4(R),V5(R),V6(R),V7(R)} is sent also to the second driver 30. The video information is converted into voltages by the driver 30 and these voltages are applied to the selected luminous elements. The graph at the bottom-right corner of figure 16 shows the used diode dynamic when the output L3 is selected and when the set of reference

10 voltages are distributed between 3 volts ($=V7(R)=VR_{th}$) and about 5,4 volts $=V0(G)$.

The final matrix of the display device is based on a cyclical repetition of the basic 3x3 matrix presented Figure 12 as illustrated by Figure 17.

15

Generally speaking, a standard driver usage is kept according the invention. The outputs L_j of the driver 20 are activated sequentially and, at each time an output L_j is activated, video information are delivered on all outputs C_i of the driver 30.

20

On the other hand, Figure 12 shows that there is a complex networking required to have the proper signal dedicated to the proper luminous element. In any case, there is no need of fast addressing as in the solution presented in the preamble of the present specification. A video data rearrangement is

25 just needed in the signal processing unit 40. A permutation between the video data inside each 3x3 matrix is needed. This permutation can be the following one for a QVGA (320x3 columns and 240 rows of luminous elements):

30

Data(3i;3j) \Rightarrow Data(3i;3j) (unchanged)
 Data(3i+1;3j) \Rightarrow Data(3i;3j+1)
 Data(3i+2;3j) \Rightarrow Data(3i;3j+2)

$\text{Data}(3i;3j+1) \Rightarrow \text{Data}(3i+1;3j)$
 $\text{Data}(3i+1;3j+1) \Rightarrow \text{Data}(3i+1;3j+1)$ (unchanged)
 $\text{Data}(3i+2;3j+1) \Rightarrow \text{Data}(3i+1;3j+2)$
 $\text{Data}(3i;3j+2) \Rightarrow \text{Data}(3i+2;3j)$
 5 $\text{Data}(3i+1;3j+2) \Rightarrow \text{Data}(3i+2;3j+1)$
 $\text{Data}(3i+2;3j+2) \Rightarrow \text{Data}(3i+2;3j+2)$ (unchanged)

where $\text{Data}(i,j)$ designates the data to be displayed by the luminous elements belonging to column i and row j of the matrix.

10 In summary, each output L_j activates the same colour component on three consecutive rows of the matrix. Then, the reference voltages (currents) are adjusted to the video information addressing so that each time a new output L_j is activated the corresponding reference voltages (currents) are transmitted to the driver 30.

15

To reduce the cost of the display device, this matrix organization can be combined with a different second driver (data driver) that is less expensive. Indeed, the data drivers are the most expensive components whereas the row drivers are simpler and can be even integrated directly on the TFT-
 20 backplane (TFT = Thin Film Transistor) of the matrix. Figure 18 illustrates a display device where the second driver 30 comprises only 320 outputs (instead of 3×320 outputs) and the first driver 20 comprises 240×3 outputs (instead of 240 outputs). The driver 20 comprises three times more outputs than previously but the driver 30 comprises three times less outputs than
 25 previously. The cost of the display device is reduced because the cost of the driver 30 is reduced. In this embodiment, 720 rows are sequentially addressed instead of 240 rows. The red luminous elements of the row j of the matrix are connected to the output LR_j of the driver 20. The green luminous elements of the row j of the matrix are connected to the output LG_j
 30 of the driver 20. The blue luminous elements of the row j of the matrix are connected to the output LB_j of the driver 20. A same column output C_i is

connected to three consecutive luminous elements connected to three different row outputs. In this embodiment, the flow of video information is rearranged differently.

5 Data(3i;j)=>Data(i;j)
 Data(3i+1;j)=>Data(319+i;j)
 Data(3i+2;j)=>Data(639+i;j)

In this embodiment, two consecutive outputs of the driver 20 are always connected to luminous elements associated to different colour components. For example, the output LR1 is consecutive to the output LB0 and LR1 is
 10 connected to red luminous elements while LB0 is connected to blue luminous elements.

In a variant illustrated by Figure 19, two consecutive outputs of the driver 20 are not always connected to luminous elements associated to different
 15 colour components. For example, the output LB1 is consecutive to the output LB0 and are both connected to blue luminous elements. In this embodiment, the flow of video information is rearranged differently.

- for rows numbered $j \bmod 6$, $j+1 \bmod 6$ and $j+2 \bmod 6$, $\forall j \in \mathbb{N}$

20 Data(3i;j)=>Data(i;j)
 Data(3i+1;j)=>Data(319+i;j)
 Data(3i+2;j)=>Data(639+i;j)

- for rows numbered $j+3 \bmod 6$, $j+4 \bmod 6$ and $j+5 \bmod 6$, $\forall j \in \mathbb{N}$

25 Data(3i;j)=>Data(639+i;j)
 Data(3i+1;j)=>Data(319+i;j)
 Data(3i+2;j)=>Data(i;j)

These two embodiments (figures 18 and 19) have a reduced cost but require a higher addressing speed (3 times faster) since three times more rows must be addressed per frame.

30

This matrix organization presented in the above-mentioned embodiments with a Red, Green, Blue standard alignment (all colour components on the same row of the matrix) requires a complex active matrix networking. A simplification of the layout of the active matrix can be obtained by using a vertical colour adjustment as illustrated by Figure 20. In this figure, the luminous elements of the matrix are arranged into 240x3 rows and 320 columns. All colour components (red, green, blue) are represented on a same column of the matrix. In this figure, the second driver 30 comprises 320x3=960 outputs and the first driver 20 comprises 240/3=80 outputs. The red luminous elements of a group of nine consecutive rows of the matrix are connected to the output L_j of the driver 20. The green luminous elements of this group of nine consecutive rows are connected to the output L_{j+1} of the driver 20 and the blue luminous elements of the group of nine consecutive rows are connected to the output L_{j+2} of the driver 20. A same column output C_i is connected to three luminous elements of said group of rows, each one of these luminous elements being connected to a different row output L_j . In this embodiment, the flow of video information is also rearranged.

The invention is not restricted to the disclosed embodiments. Various modifications are possible and are considered to fall within the scope of the claims, e.g. other OLED materials with other threshold voltages and efficiencies can be used.

ANNEX 1

Level	Voltage
0	V7
1	$V7+(V6-V7) \times 9/1175$
2	$V7+(V6-V7) \times 32/1175$
3	$V7+(V6-V7) \times 76/1175$
4	$V7+(V6-V7) \times 141/1175$
5	$V7+(V6-V7) \times 224/1175$
6	$V7+(V6-V7) \times 321/1175$
7	$V7+(V6-V7) \times 425/1175$
8	$V7+(V6-V7) \times 529/1175$
9	$V7+(V6-V7) \times 630/1175$
10	$V7+(V6-V7) \times 727/1175$
11	$V7+(V6-V7) \times 820/1175$
12	$V7+(V6-V7) \times 910/1175$
13	$V7+(V6-V7) \times 998/1175$
14	$V7+(V6-V7) \times 1086/1175$
15	V6
16	$V6+(V5-V6) \times 89/1097$
17	$V6+(V5-V6) \times 173/1097$
18	$V6+(V5-V6) \times 250/1097$
19	$V6+(V5-V6) \times 320/1097$
20	$V6+(V5-V6) \times 386/1097$
21	$V6+(V5-V6) \times 451/1097$
22	$V6+(V5-V6) \times 517/1097$
23	$V6+(V5-V6) \times 585/1097$
24	$V6+(V5-V6) \times 654/1097$
25	$V6+(V5-V6) \times 723/1097$
26	$V6+(V5-V6) \times 790/1097$
27	$V6+(V5-V6) \times 855/1097$
28	$V6+(V5-V6) \times 917/1097$
29	$V6+(V5-V6) \times 977/1097$
30	$V6+(V5-V6) \times 1037/1097$
31	V5
32	$V5+(V4-V5) \times 60/1501$

33	$V5+(V4-V5) \times 119/1501$
34	$V5+(V4-V5) \times 176/1501$
35	$V5+(V4-V5) \times 231/1501$
36	$V5+(V4-V5) \times 284/1501$
37	$V5+(V4-V5) \times 335/1501$
38	$V5+(V4-V5) \times 385/1501$
39	$V5+(V4-V5) \times 434/1501$
40	$V5+(V4-V5) \times 483/1501$
41	$V5+(V4-V5) \times 532/1501$
42	$V5+(V4-V5) \times 580/1501$
43	$V5+(V4-V5) \times 628/1501$
44	$V5+(V4-V5) \times 676/1501$
45	$V5+(V4-V5) \times 724/1501$
46	$V5+(V4-V5) \times 772/1501$
47	$V5+(V4-V5) \times 819/1501$
48	$V5+(V4-V5) \times 866/1501$
49	$V5+(V4-V5) \times 912/1501$
50	$V5+(V4-V5) \times 957/1501$
51	$V5+(V4-V5) \times 1001/1501$
52	$V5+(V4-V5) \times 1045/1501$
53	$V5+(V4-V5) \times 1088/1501$
54	$V5+(V4-V5) \times 1131/1501$
55	$V5+(V4-V5) \times 1173/1501$
56	$V5+(V4-V5) \times 1215/1501$
57	$V5+(V4-V5) \times 1257/1501$
58	$V5+(V4-V5) \times 1298/1501$
59	$V5+(V4-V5) \times 1339/1501$
60	$V5+(V4-V5) \times 1380/1501$
61	$V5+(V4-V5) \times 1421/1501$
62	$V5+(V4-V5) \times 1461/1501$
63	V4
64	$V4+(V3-V4) \times 40/2215$
65	$V4+(V3-V4) \times 80/2215$
66	$V4+(V3-V4) \times 120/2215$

67	$V4+(V3-V4)\times 160/2215$
68	$V4+(V3-V4)\times 200/2215$
69	$V4+(V3-V4)\times 240/2215$
70	$V4+(V3-V4)\times 280/2215$
71	$V4+(V3-V4)\times 320/2215$
72	$V4+(V3-V4)\times 360/2215$
73	$V4+(V3-V4)\times 400/2215$
74	$V4+(V3-V4)\times 440/2215$
75	$V4+(V3-V4)\times 480/2215$
76	$V4+(V3-V4)\times 520/2215$
77	$V4+(V3-V4)\times 560/2215$
78	$V4+(V3-V4)\times 600/2215$
79	$V4+(V3-V4)\times 640/2215$
80	$V4+(V3-V4)\times 680/2215$
81	$V4+(V3-V4)\times 719/2215$
82	$V4+(V3-V4)\times 758/2215$
83	$V4+(V3-V4)\times 796/2215$
84	$V4+(V3-V4)\times 834/2215$
85	$V4+(V3-V4)\times 871/2215$
86	$V4+(V3-V4)\times 908/2215$
87	$V4+(V3-V4)\times 944/2215$
88	$V4+(V3-V4)\times 980/2215$
89	$V4+(V3-V4)\times 1016/2215$
90	$V4+(V3-V4)\times 1052/2215$
91	$V4+(V3-V4)\times 1087/2215$
92	$V4+(V3-V4)\times 1122/2215$
93	$V4+(V3-V4)\times 1157/2215$
94	$V4+(V3-V4)\times 1192/2215$
95	$V4+(V3-V4)\times 1226/2215$
96	$V4+(V3-V4)\times 1260/2215$
97	$V4+(V3-V4)\times 1294/2215$
98	$V4+(V3-V4)\times 1328/2215$
99	$V4+(V3-V4)\times 1362/2215$
100	$V4+(V3-V4)\times 1396/2215$
101	$V4+(V3-V4)\times 1429/2215$
102	$V4+(V3-V4)\times 1462/2215$

103	$V4+(V3-V4)\times 1495/2215$
104	$V4+(V3-V4)\times 1528/2215$
105	$V4+(V3-V4)\times 1561/2215$
106	$V4+(V3-V4)\times 1593/2215$
107	$V4+(V3-V4)\times 1625/2215$
108	$V4+(V3-V4)\times 1657/2215$
109	$V4+(V3-V4)\times 1688/2215$
110	$V4+(V3-V4)\times 1719/2215$
111	$V4+(V3-V4)\times 1750/2215$
112	$V4+(V3-V4)\times 1781/2215$
113	$V4+(V3-V4)\times 1811/2215$
114	$V4+(V3-V4)\times 1841/2215$
115	$V4+(V3-V4)\times 1871/2215$
116	$V4+(V3-V4)\times 1901/2215$
117	$V4+(V3-V4)\times 1930/2215$
118	$V4+(V3-V4)\times 1959/2215$
119	$V4+(V3-V4)\times 1988/2215$
120	$V4+(V3-V4)\times 2016/2215$
121	$V4+(V3-V4)\times 2044/2215$
122	$V4+(V3-V4)\times 2072/2215$
123	$V4+(V3-V4)\times 2100/2215$
124	$V4+(V3-V4)\times 2128/2215$
125	$V4+(V3-V4)\times 2156/2215$
126	$V4+(V3-V4)\times 2185/2215$
127	V3
128	$V3+(V2-V3)\times 31/2343$
129	$V3+(V2-V3)\times 64/2343$
130	$V3+(V2-V3)\times 97/2343$
131	$V3+(V2-V3)\times 130/2343$
132	$V3+(V2-V3)\times 163/2343$
133	$V3+(V2-V3)\times 196/2343$
134	$V3+(V2-V3)\times 229/2343$
135	$V3+(V2-V3)\times 262/2343$
136	$V3+(V2-V3)\times 295/2343$
137	$V3+(V2-V3)\times 328/2343$
138	$V3+(V2-V3)\times 361/2343$

139	$V3+(V2-V3) \times 395/2343$
140	$V3+(V2-V3) \times 429/2343$
141	$V3+(V2-V3) \times 463/2343$
142	$V3+(V2-V3) \times 497/2343$
143	$V3+(V2-V3) \times 531/2343$
144	$V3+(V2-V3) \times 566/2343$
145	$V3+(V2-V3) \times 601/2343$
146	$V3+(V2-V3) \times 636/2343$
147	$V3+(V2-V3) \times 671/2343$
148	$V3+(V2-V3) \times 706/2343$
149	$V3+(V2-V3) \times 741/2343$
150	$V3+(V2-V3) \times 777/2343$
151	$V3+(V2-V3) \times 813/2343$
152	$V3+(V2-V3) \times 849/2343$
153	$V3+(V2-V3) \times 885/2343$
154	$V3+(V2-V3) \times 921/2343$
155	$V3+(V2-V3) \times 958/2343$
156	$V3+(V2-V3) \times 995/2343$
157	$V3+(V2-V3) \times 1032/2343$
158	$V3+(V2-V3) \times 1069/2343$
159	$V3+(V2-V3) \times 1106/2343$
160	$V3+(V2-V3) \times 1143/2343$
161	$V3+(V2-V3) \times 1180/2343$
162	$V3+(V2-V3) \times 1217/2343$
163	$V3+(V2-V3) \times 1255/2343$
164	$V3+(V2-V3) \times 1293/2343$
165	$V3+(V2-V3) \times 1331/2343$
166	$V3+(V2-V3) \times 1369/2343$
167	$V3+(V2-V3) \times 1407/2343$
168	$V3+(V2-V3) \times 1445/2343$
169	$V3+(V2-V3) \times 1483/2343$
170	$V3+(V2-V3) \times 1521/2343$
171	$V3+(V2-V3) \times 1559/2343$
172	$V3+(V2-V3) \times 1597/2343$
173	$V3+(V2-V3) \times 1635/2343$
174	$V3+(V2-V3) \times 1673/2343$

175	$V3+(V2-V3) \times 1712/2343$
176	$V3+(V2-V3) \times 1751/2343$
177	$V3+(V2-V3) \times 1790/2343$
178	$V3+(V2-V3) \times 1829/2343$
179	$V3+(V2-V3) \times 1868/2343$
180	$V3+(V2-V3) \times 1907/2343$
181	$V3+(V2-V3) \times 1946/2343$
182	$V3+(V2-V3) \times 1985/2343$
183	$V3+(V2-V3) \times 2024/2343$
184	$V3+(V2-V3) \times 2064/2343$
185	$V3+(V2-V3) \times 2103/2343$
186	$V3+(V2-V3) \times 2143/2343$
187	$V3+(V2-V3) \times 2183/2343$
188	$V3+(V2-V3) \times 2223/2343$
189	$V3+(V2-V3) \times 2263/2343$
190	$V3+(V2-V3) \times 2303/2343$
191	$V2$
192	$V2+(V1-V2) \times 40/1638$
193	$V2+(V1-V2) \times 81/1638$
194	$V2+(V1-V2) \times 124/1638$
195	$V2+(V1-V2) \times 168/1638$
196	$V2+(V1-V2) \times 213/1638$
197	$V2+(V1-V2) \times 259/1638$
198	$V2+(V1-V2) \times 306/1638$
199	$V2+(V1-V2) \times 353/1638$
200	$V2+(V1-V2) \times 401/1638$
201	$V2+(V1-V2) \times 450/1638$
202	$V2+(V1-V2) \times 499/1638$
203	$V2+(V1-V2) \times 548/1638$
204	$V2+(V1-V2) \times 597/1638$
205	$V2+(V1-V2) \times 646/1638$
206	$V2+(V1-V2) \times 695/1638$
207	$V2+(V1-V2) \times 745/1638$
208	$V2+(V1-V2) \times 795/1638$
209	$V2+(V1-V2) \times 846/1638$
210	$V2+(V1-V2) \times 897/1638$

211	$V2+(V1-V2)\times 949/1638$
212	$V2+(V1-V2)\times 1002/1638$
213	$V2+(V1-V2)\times 1056/1638$
214	$V2+(V1-V2)\times 1111/1638$
215	$V2+(V1-V2)\times 1167/1638$
216	$V2+(V1-V2)\times 1224/1638$
217	$V2+(V1-V2)\times 1281/1638$
218	$V2+(V1-V2)\times 1339/1638$
219	$V2+(V1-V2)\times 1398/1638$
220	$V2+(V1-V2)\times 1458/1638$
221	$V2+(V1-V2)\times 1518/1638$
222	$V2+(V1-V2)\times 1578/1638$
223	V1
224	$V1+(V0-V1)\times 60/3029$
225	$V1+(V0-V1)\times 120/3029$
226	$V1+(V0-V1)\times 180/3029$
227	$V1+(V0-V1)\times 241/3029$
228	$V1+(V0-V1)\times 304/3029$
229	$V1+(V0-V1)\times 369/3029$
230	$V1+(V0-V1)\times 437/3029$
231	$V1+(V0-V1)\times 507/3029$
232	$V1+(V0-V1)\times 580/3029$
233	$V1+(V0-V1)\times 655/3029$
234	$V1+(V0-V1)\times 732/3029$
235	$V1+(V0-V1)\times 810/3029$
236	$V1+(V0-V1)\times 889/3029$
237	$V1+(V0-V1)\times 969/3029$
238	$V1+(V0-V1)\times 1050/3029$
239	$V1+(V0-V1)\times 1133/3029$
240	$V1+(V0-V1)\times 1218/3029$
241	$V1+(V0-V1)\times 1304/3029$
242	$V1+(V0-V1)\times 1393/3029$
243	$V1+(V0-V1)\times 1486/3029$
244	$V1+(V0-V1)\times 1583/3029$
245	$V1+(V0-V1)\times 1686/3029$

246	$V1+(V0-V1)\times 1794/3029$
247	$V1+(V0-V1)\times 1907/3029$
248	$V1+(V0-V1)\times 2026/3029$
249	$V1+(V0-V1)\times 2150/3029$
250	$V1+(V0-V1)\times 2278/3029$
251	$V1+(V0-V1)\times 2411/3029$
252	$V1+(V0-V1)\times 2549/3029$
253	$V1+(V0-V1)\times 2694/3029$
254	$V1+(V0-V1)\times 2851/3029$
255	V0

CLAIMS

1) Display device comprising

- 5 - an active matrix (10) containing an array of luminous elements arranged in n rows and m columns, each luminous element being associated to a colour component among k different colour components of a picture to be displayed, k being greater than 1 and the luminous elements being arranged in groups of k consecutive luminous elements each associated to a different colour component,
- 10 - a first driver (20) having p outputs (L_j) connected to the active matrix for selecting luminous elements of the matrix, each output of the first driver being connected to a different part of the matrix and the parts of the matrix being selected by the first driver one after the other,
- a second driver (30) having q outputs (C_i) connected to the active matrix
- 15 for delivering a signal to each luminous element selected by the first driver, said signal depending on the video information to be displayed by the selected luminous elements; and
- a digital processing unit (40) for delivering video information to the second driver and control signals to the first driver.
- 20 characterized in that at least one output of the first driver (20) is connected to luminous elements associated to a same colour component, the signal of the video information to be displayed by each of the luminous elements connected to said at least one output of the first driver being delivered by a separate output of the second driver (30).

25

2) Display device according to claim 1, wherein the k luminous elements of each group belong to one and the same row of luminous elements of the matrix.

- 30 3) Display device according to claim 2, wherein the first driver (20) has $p=n$ outputs and the second driver (30) has $q=m$ outputs.

- 4) Display device according to claim 3, wherein each output of the first driver (20) is connected to all luminous elements associated to a same colour component and belonging to k rows of luminous elements of the active matrix (10).
- 5) Display device according to claim 2, wherein the first driver (20) has $p=k*n$ outputs and the second driver (30) has $q=m/k$ outputs.
- 6) Display device according to claim 5, wherein each output of the first driver (20) is connected to all luminous elements associated to a same colour component and belonging to a same row of luminous elements of the matrix and each output of the second driver (30) is connected to the k luminous elements of a same group of luminous elements.
- 7) Display device according to claim 5 or 6, wherein two consecutive outputs of the first driver (20) are connected to luminous elements associated to different colour components.
- 8) Display device according to claim 5 or 6, wherein at least two consecutive outputs of the first driver (20) are connected to luminous elements associated to a same colour component.
- 9) Display device according to claim 1, wherein the k luminous elements of each group belong to one and the same column of luminous elements of the active matrix.
- 10) Display device according to claim 9, wherein the first driver (20) has $p=n/k$ outputs and the second driver (30) has $q=m*k$ outputs.

11) Display device according to claim 10, wherein k outputs of the second driver (30) are connected to luminous elements of a same column, each one of said k outputs being connected to luminous elements associated to a same colour component and each output of the first driver (20) is connected
5 to all luminous elements associated to a same colour component and belonging to a same column of luminous elements and to k rows of luminous elements of the active matrix.

12) Display device according to any one of the preceding claims, wherein
10 the video information delivered to the second driver (30) are based on sets of reference signals, a different set of reference signals being associated to at least two different colour components and wherein the digital processing unit (40) controls the first driver and delivers video information and reference signals to the second driver such that, each time the luminous elements
15 connected to an output of the first driver are selected, the digital processing unit delivers to the second driver the video information of the luminous elements selected by the first driver and the set of reference signals associated to the colour component of the selected luminous elements.

20

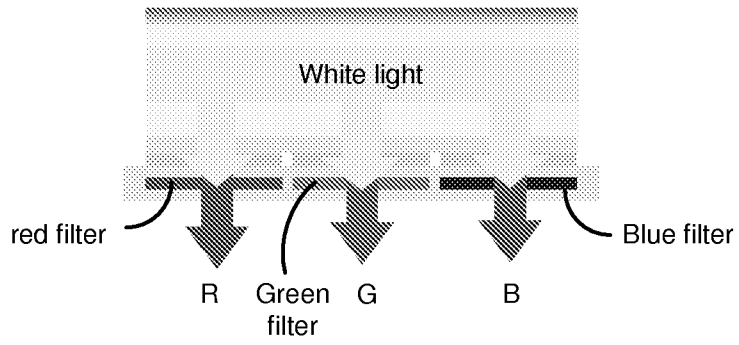

FIG.1

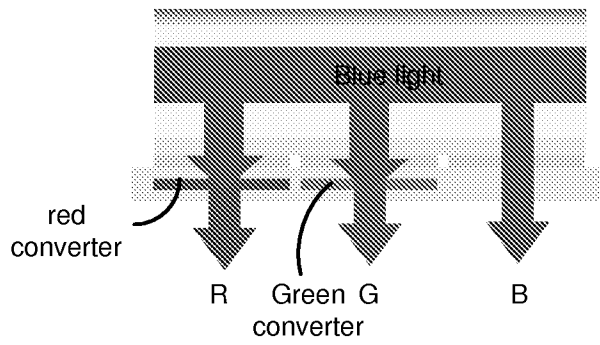

FIG.2

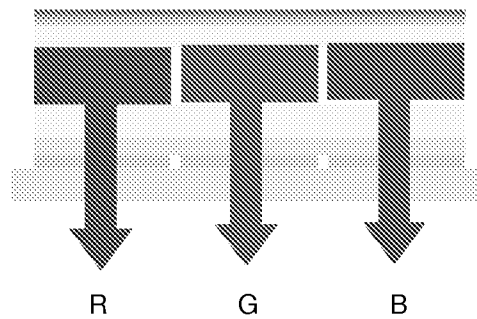

FIG.3

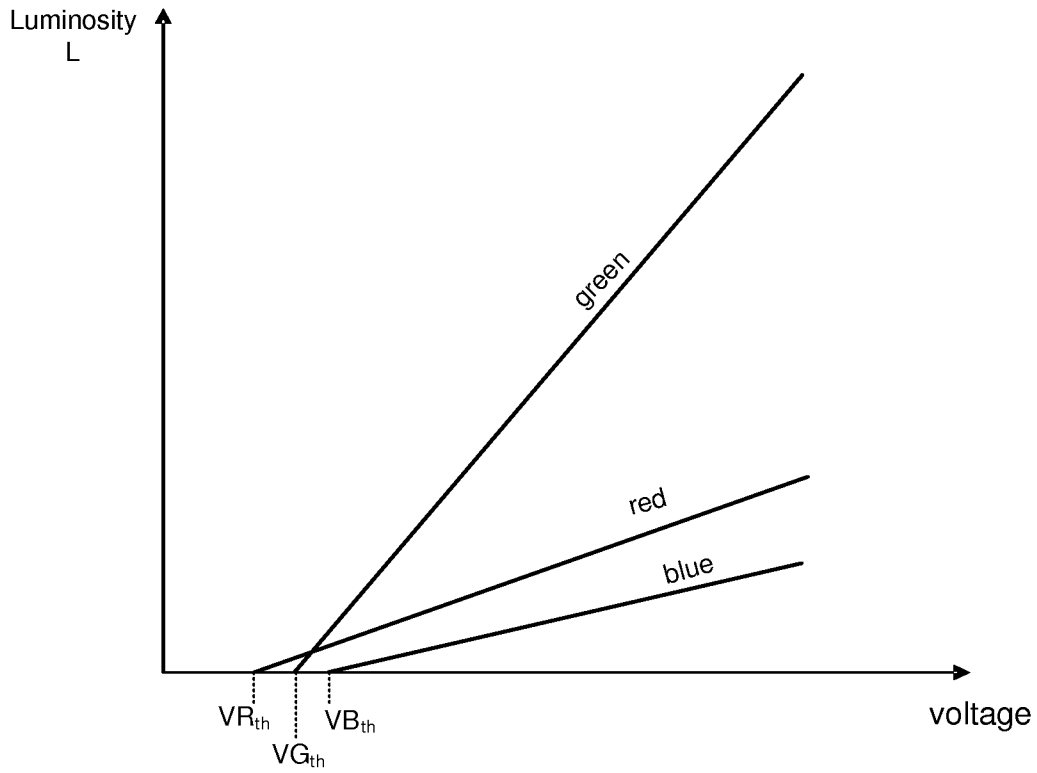

FIG.4

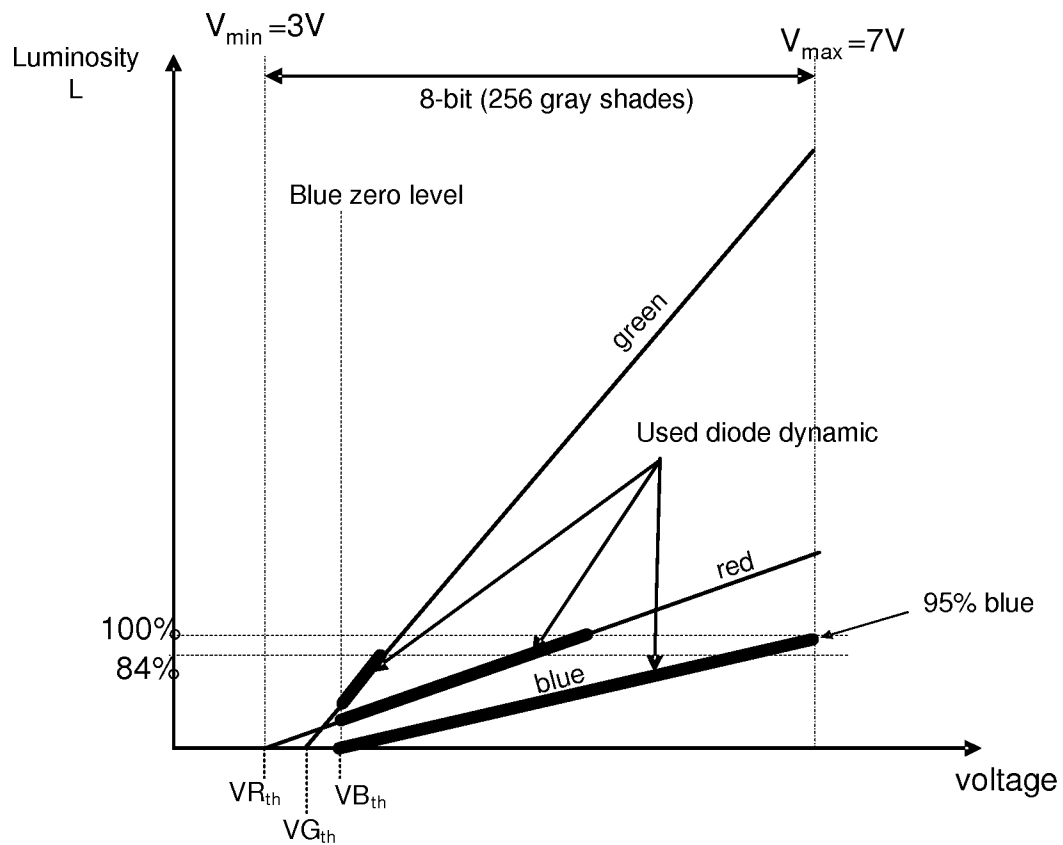

FIG.5

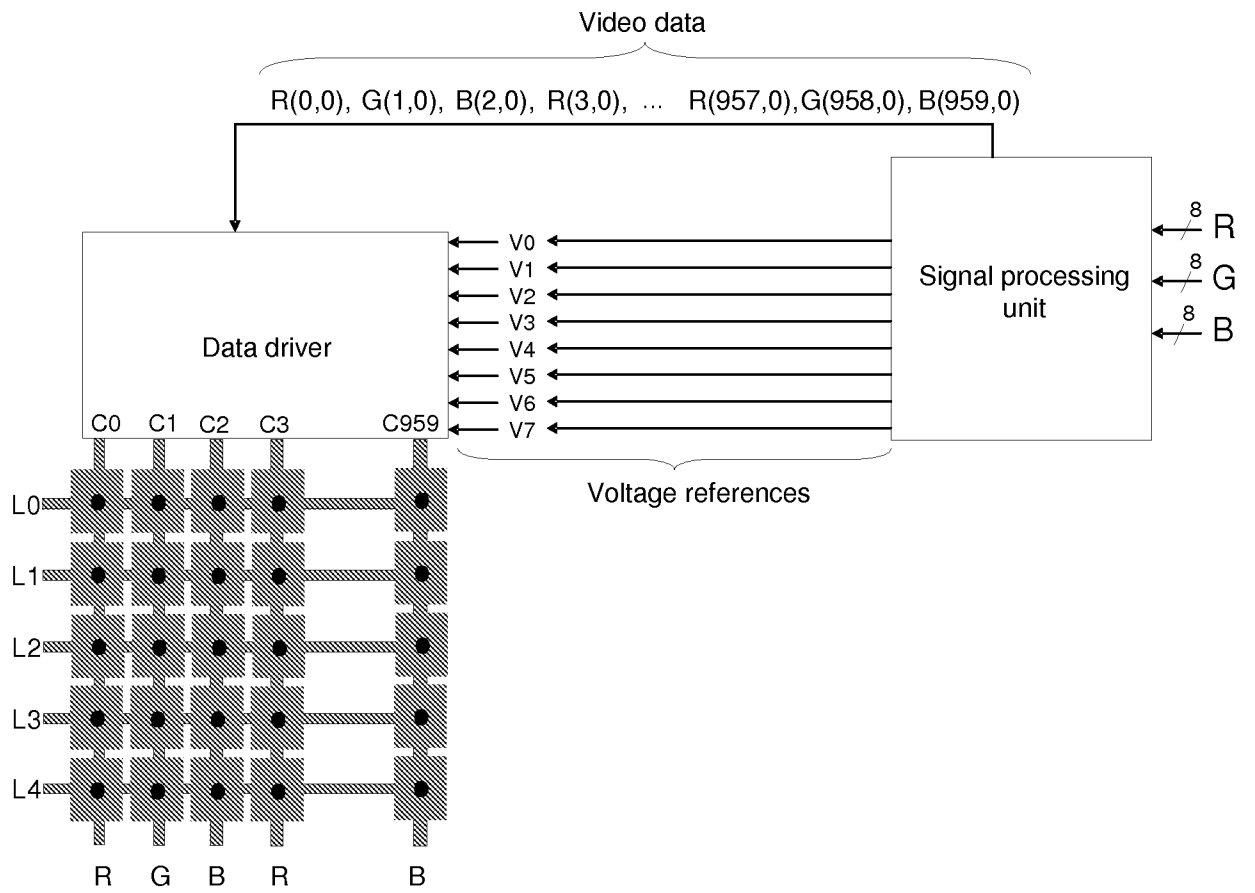

FIG.6 (prior art)

4/17

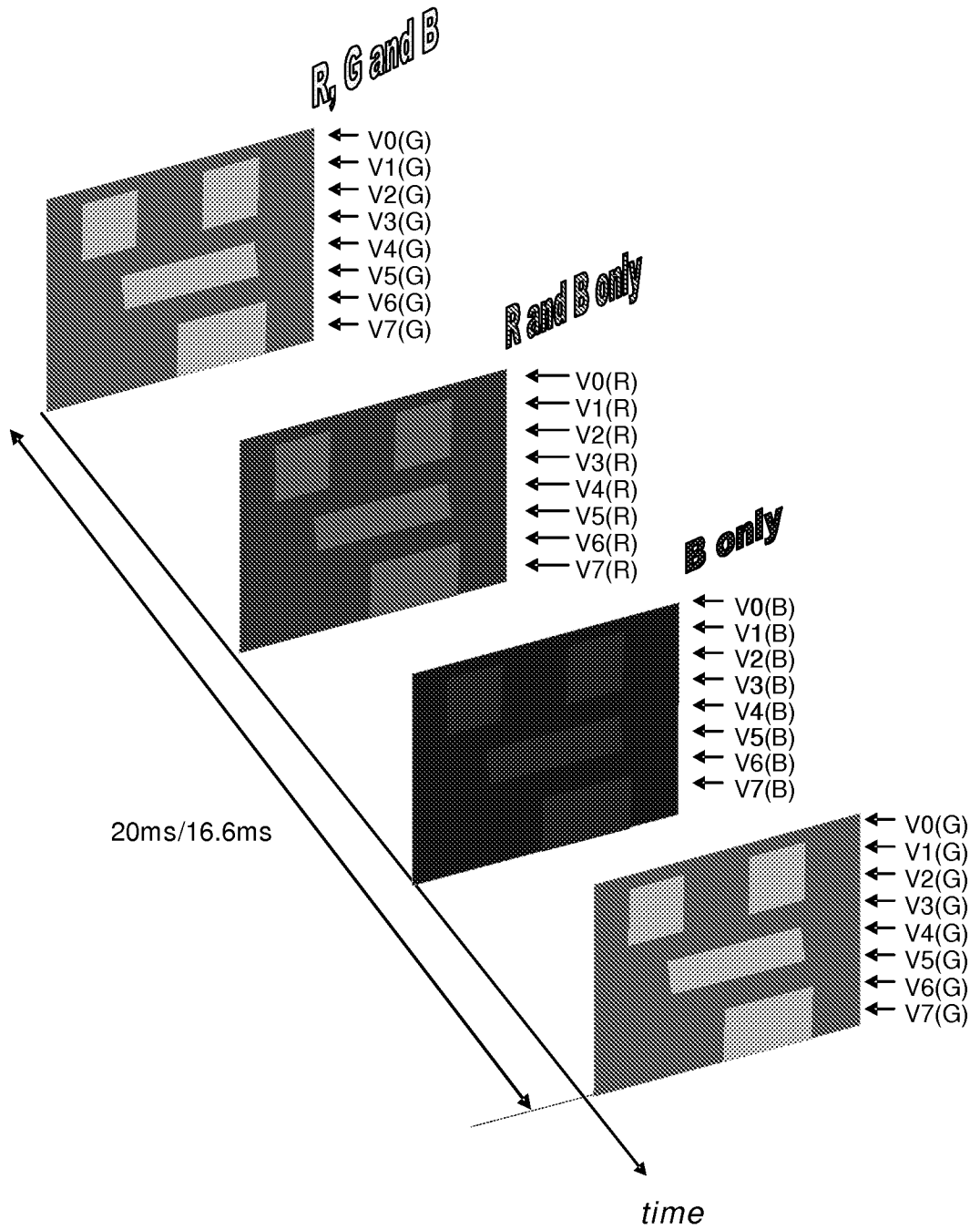

FIG.7

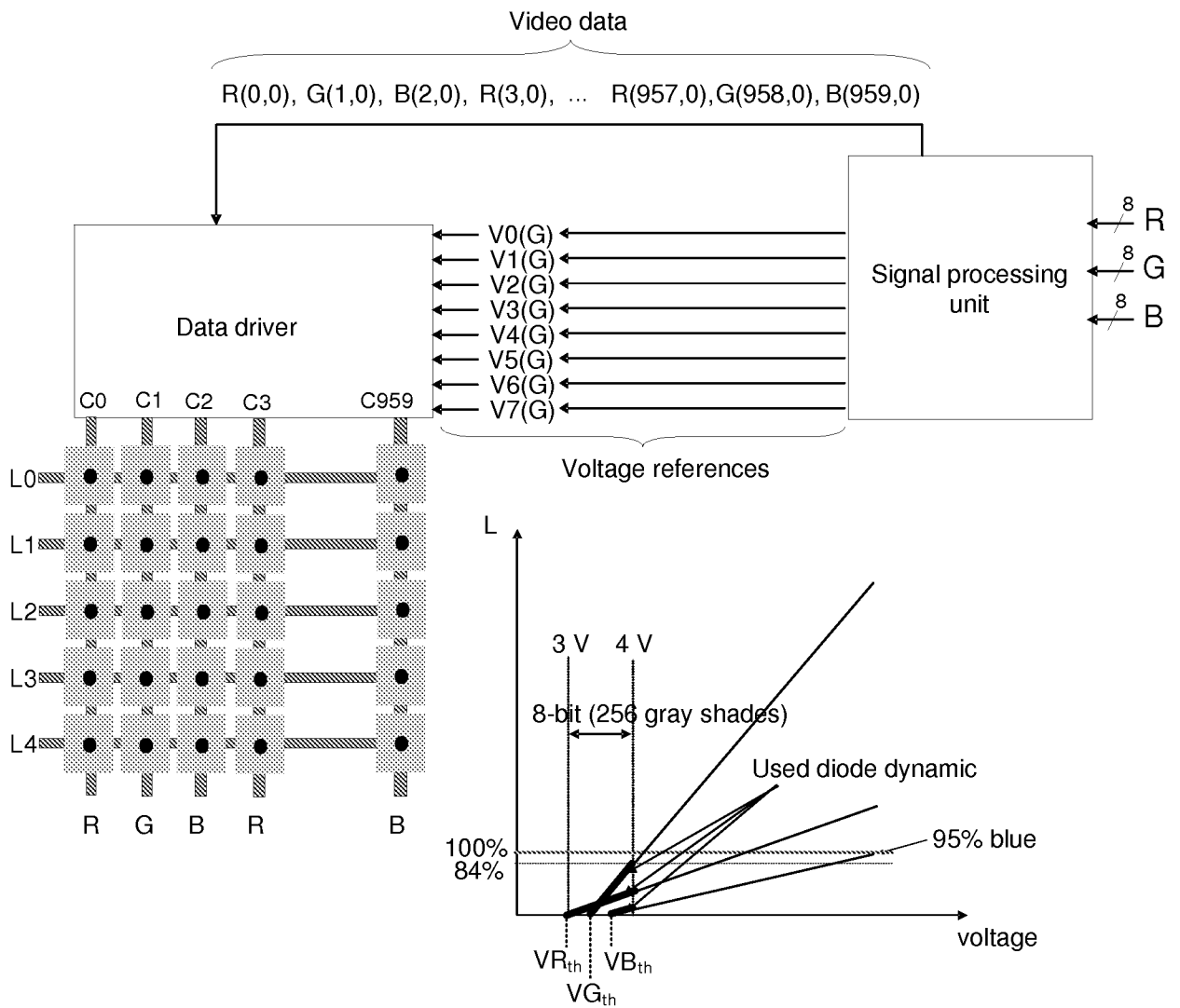

FIG.8

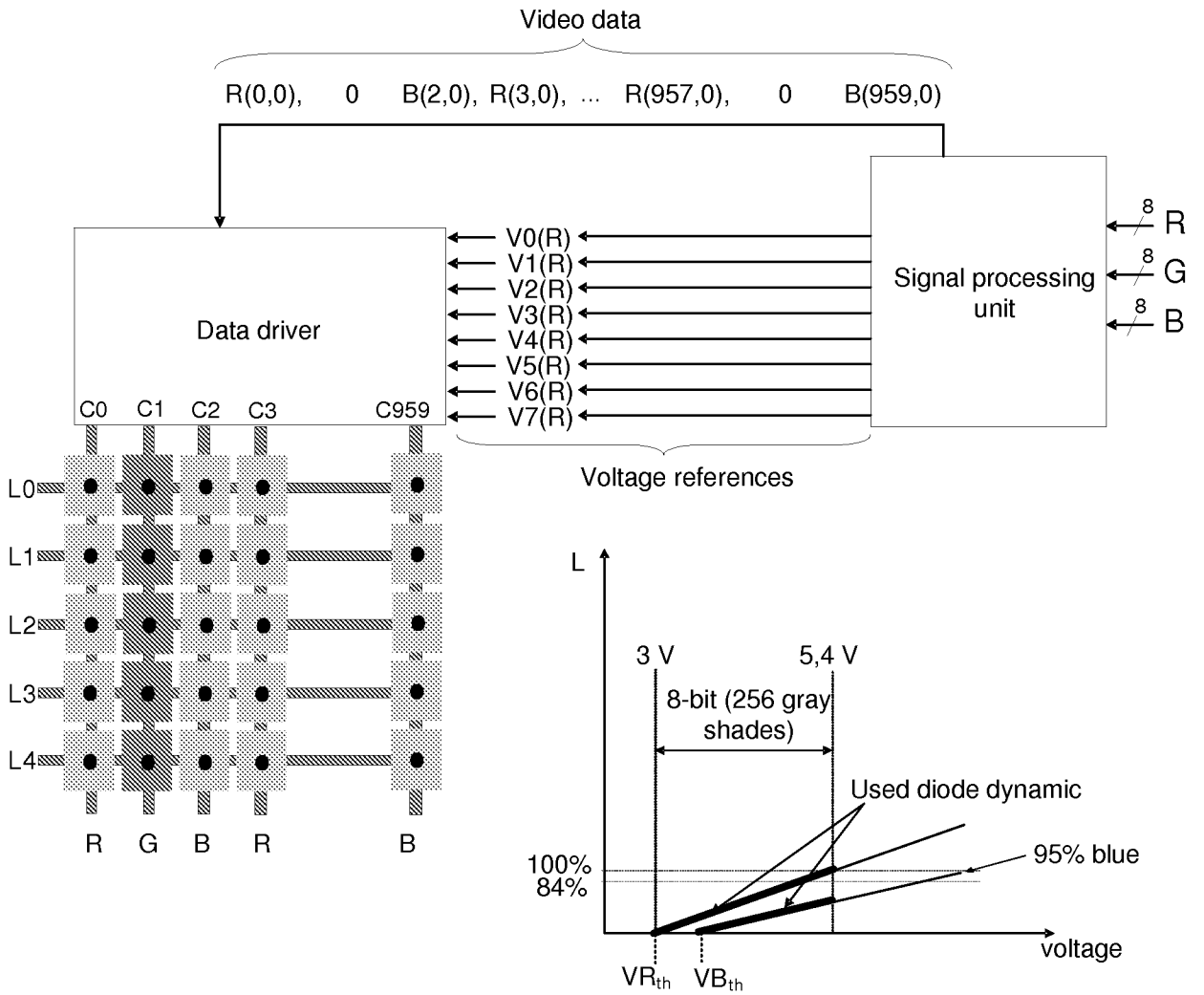

FIG.9

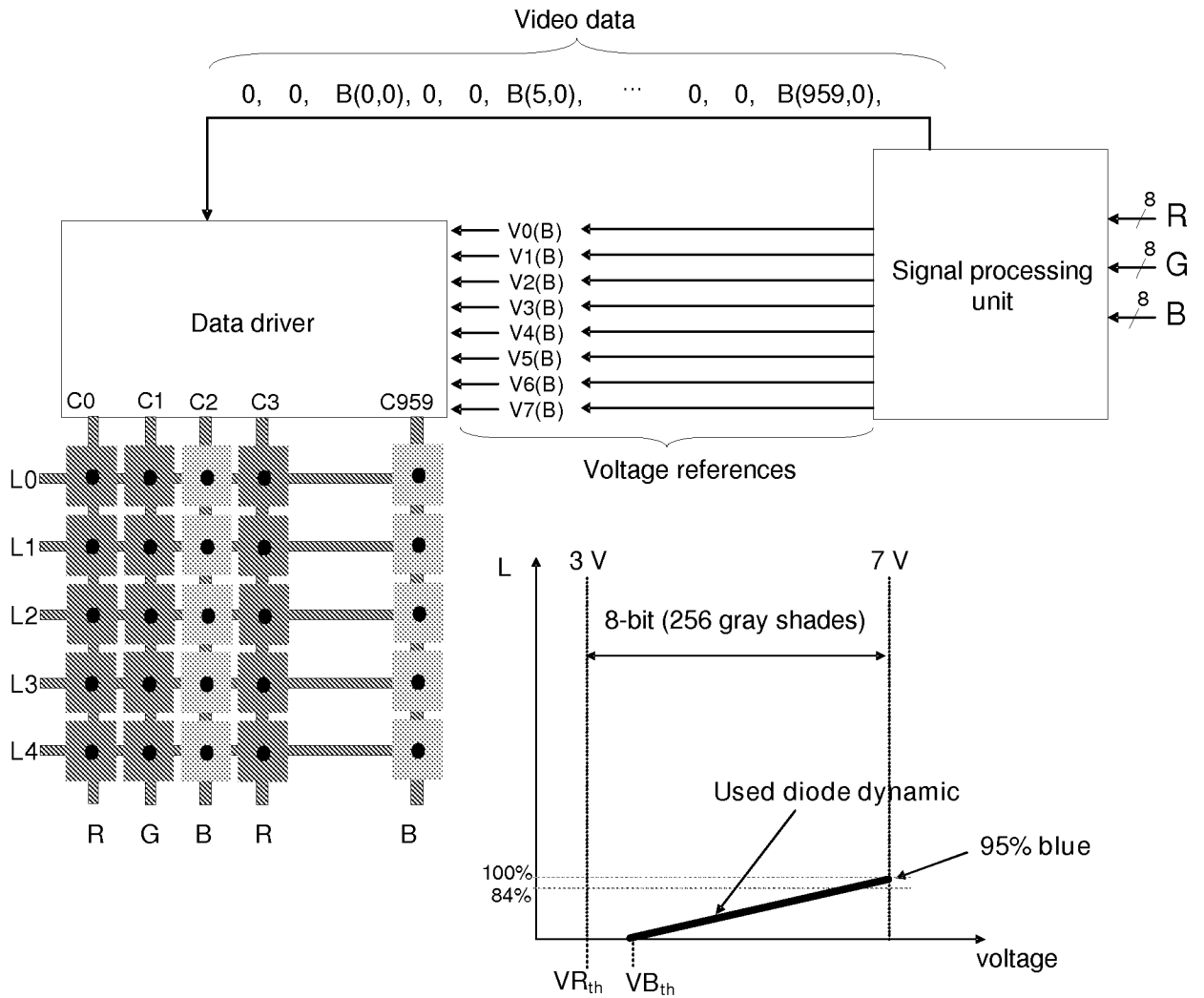

FIG.10

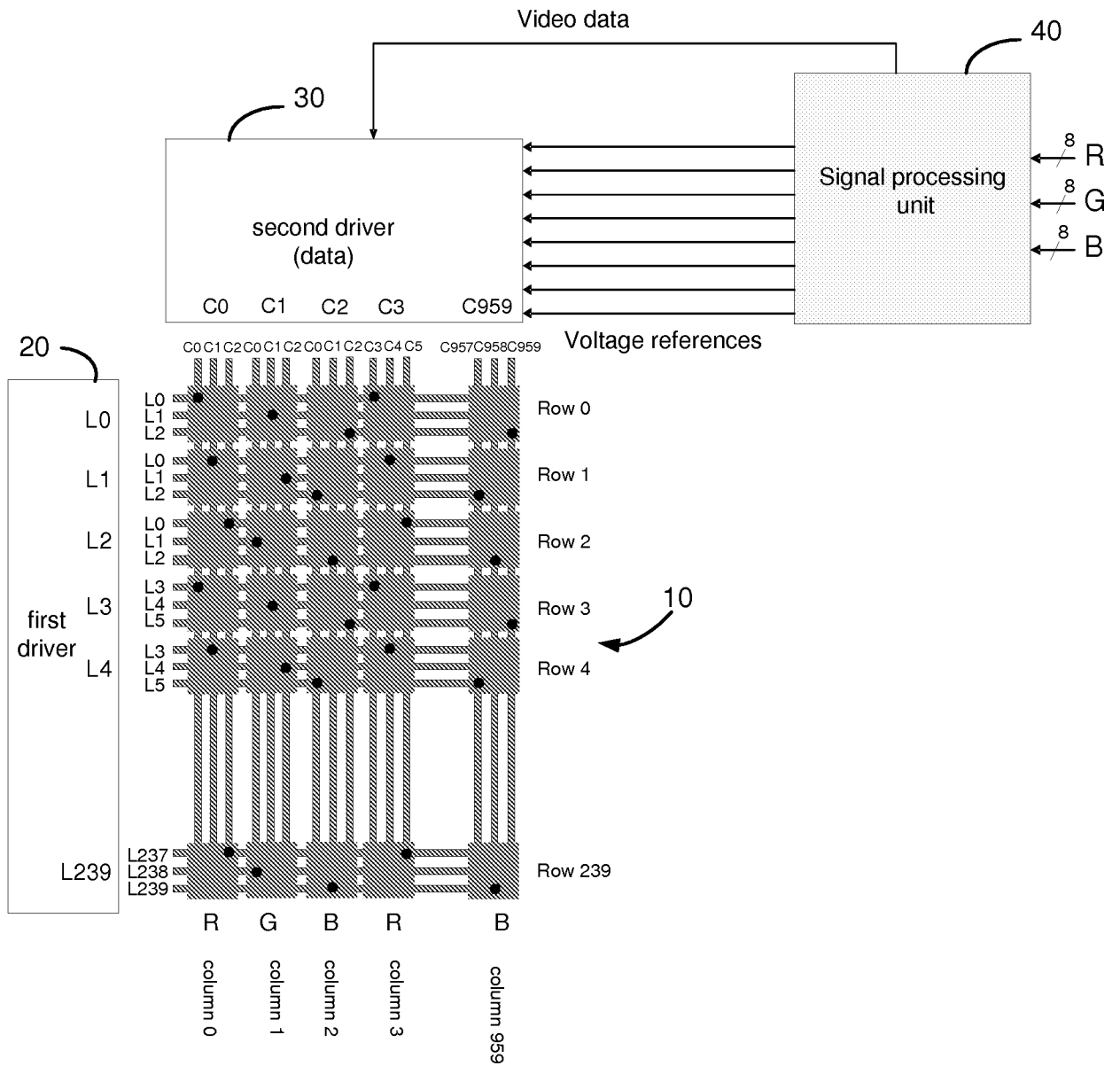

FIG.11

9/17

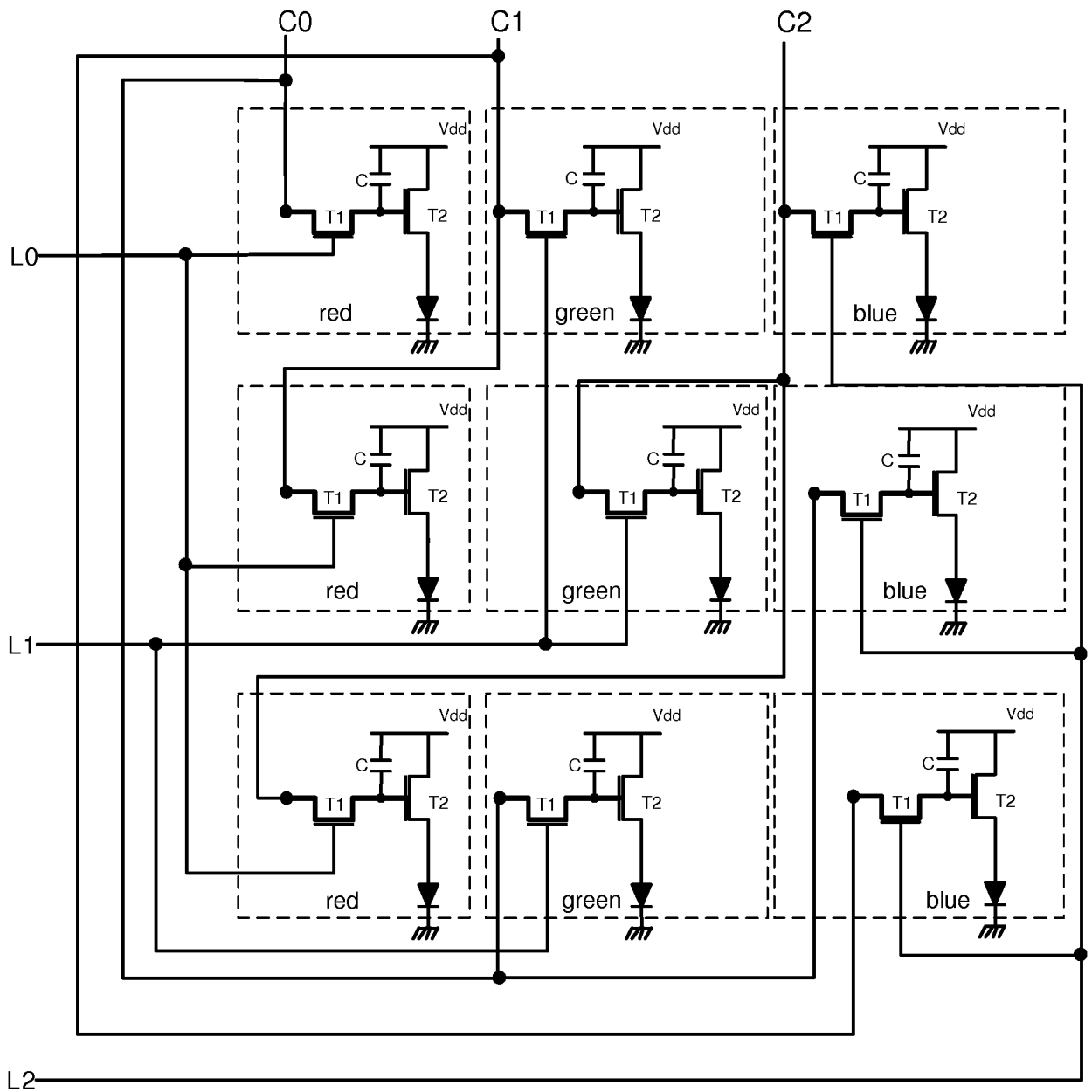

FIG.12

10/17

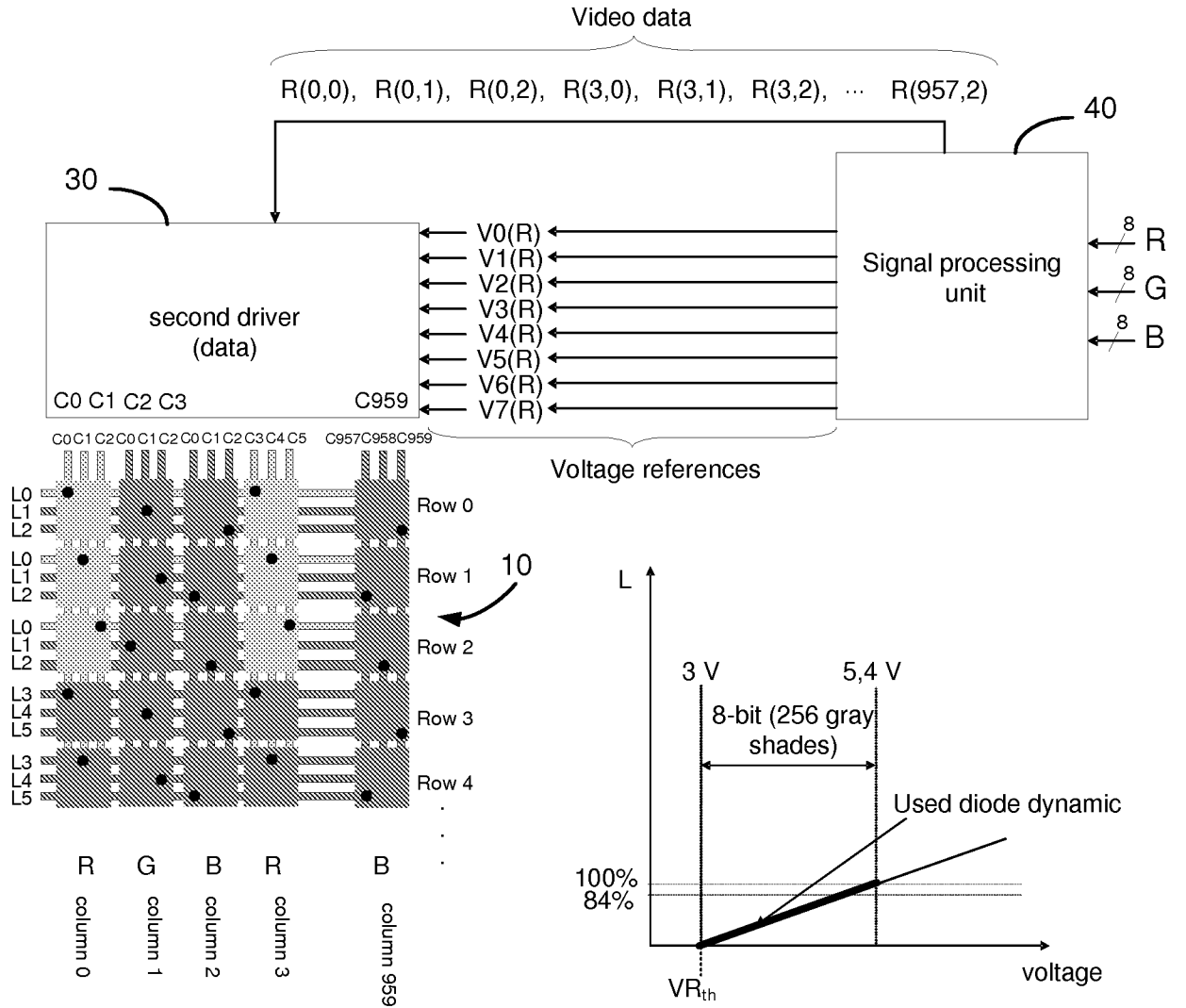

FIG.13

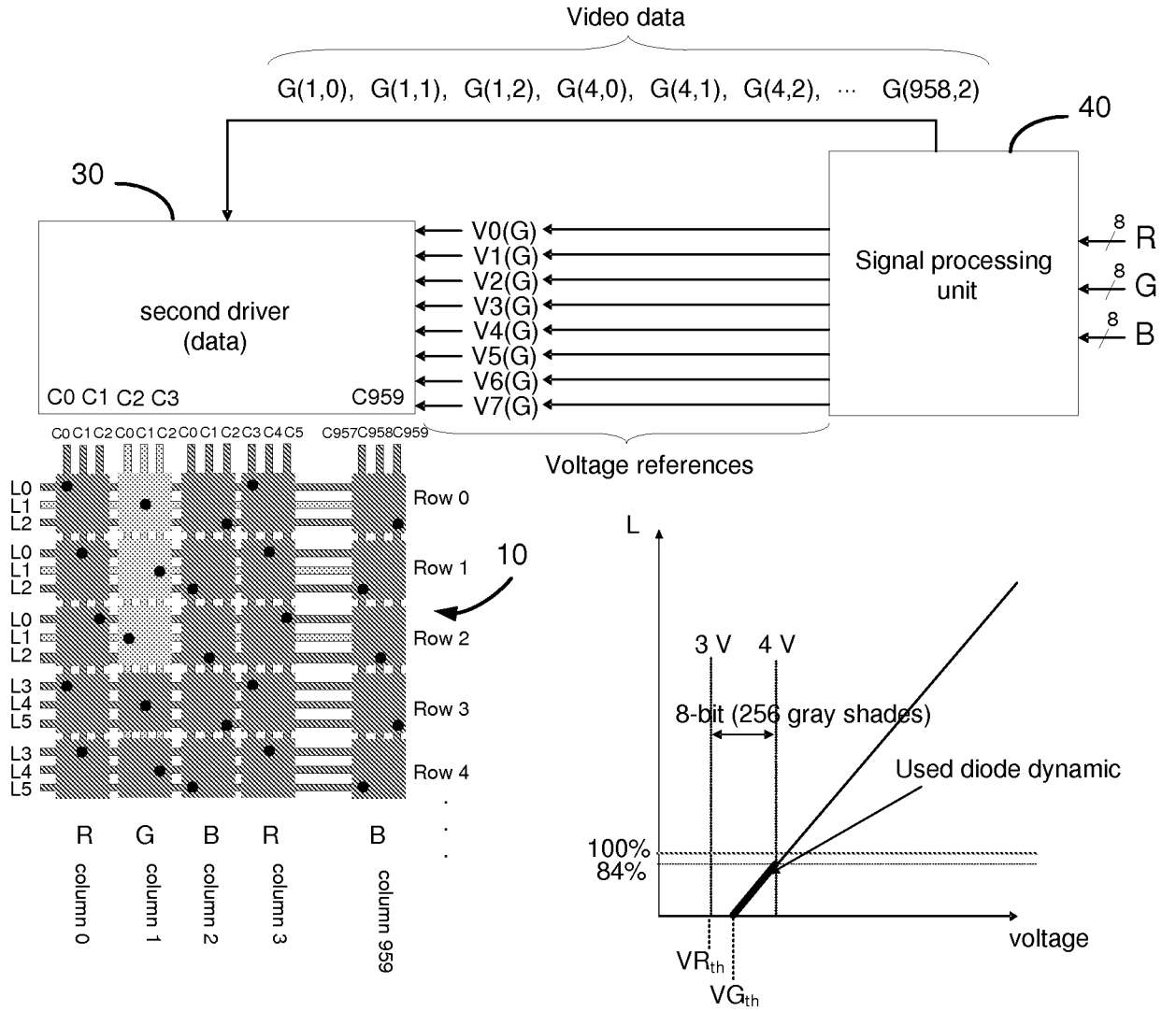

FIG.14

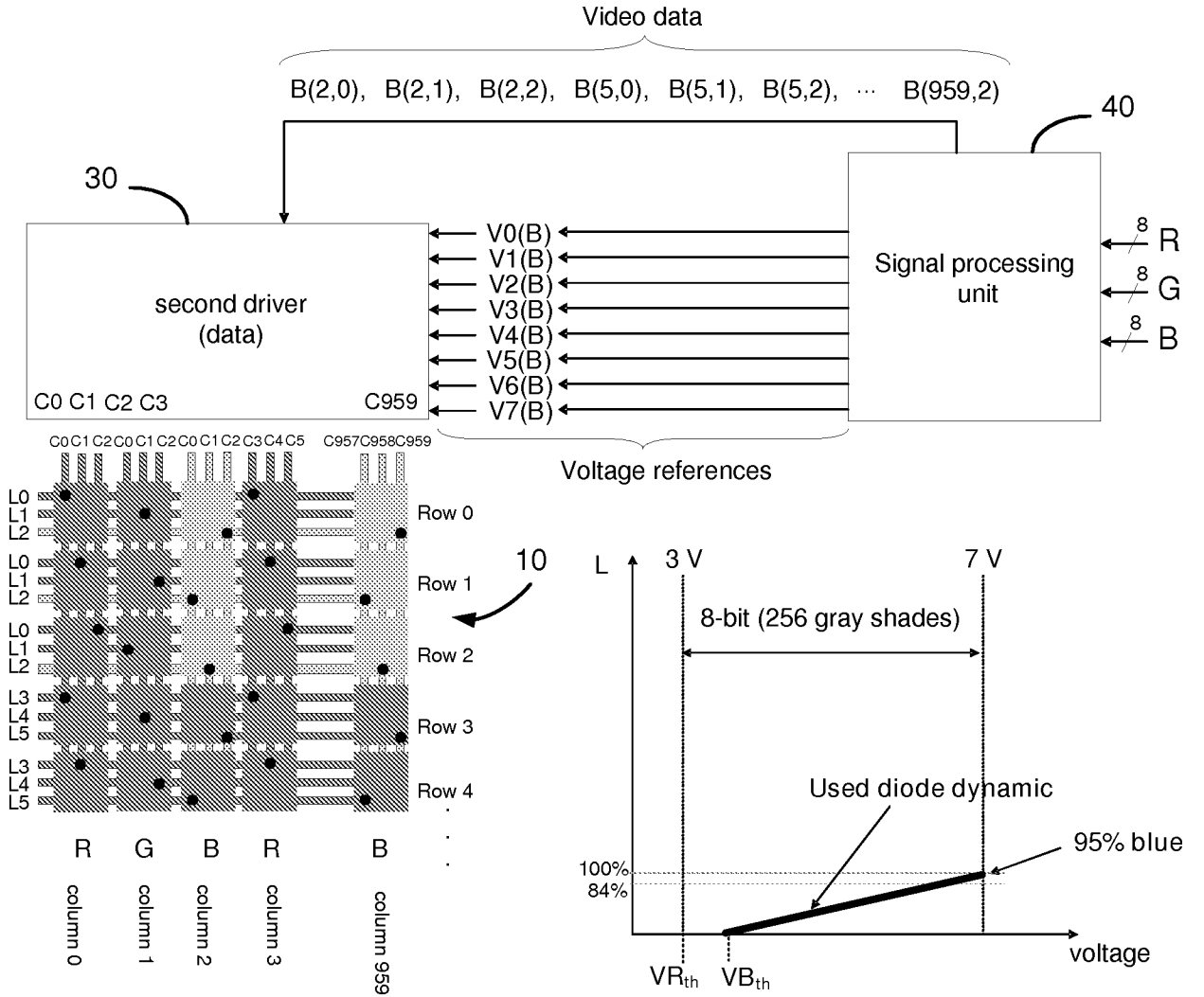

FIG.15

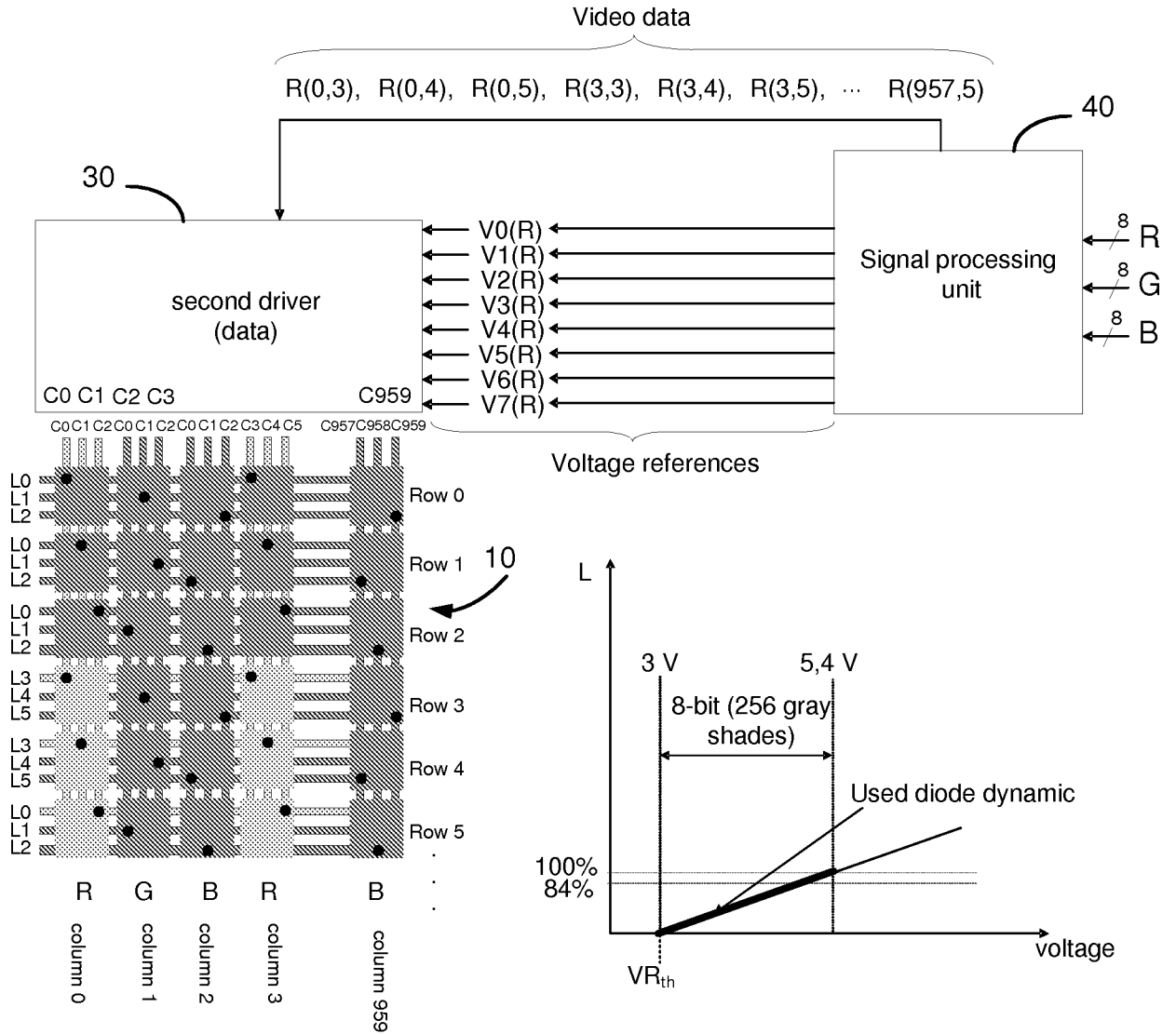

FIG.16

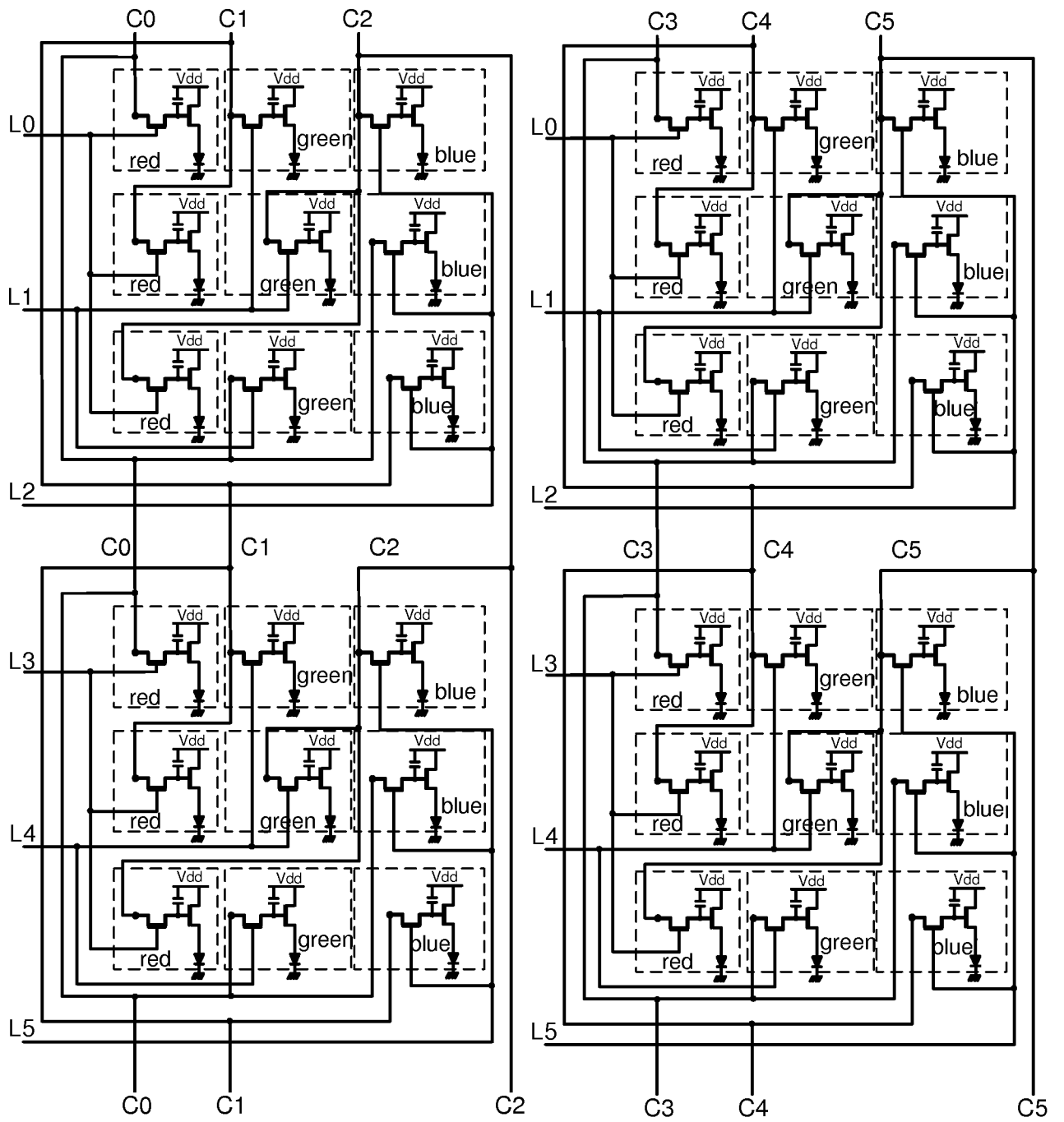

FIG.17

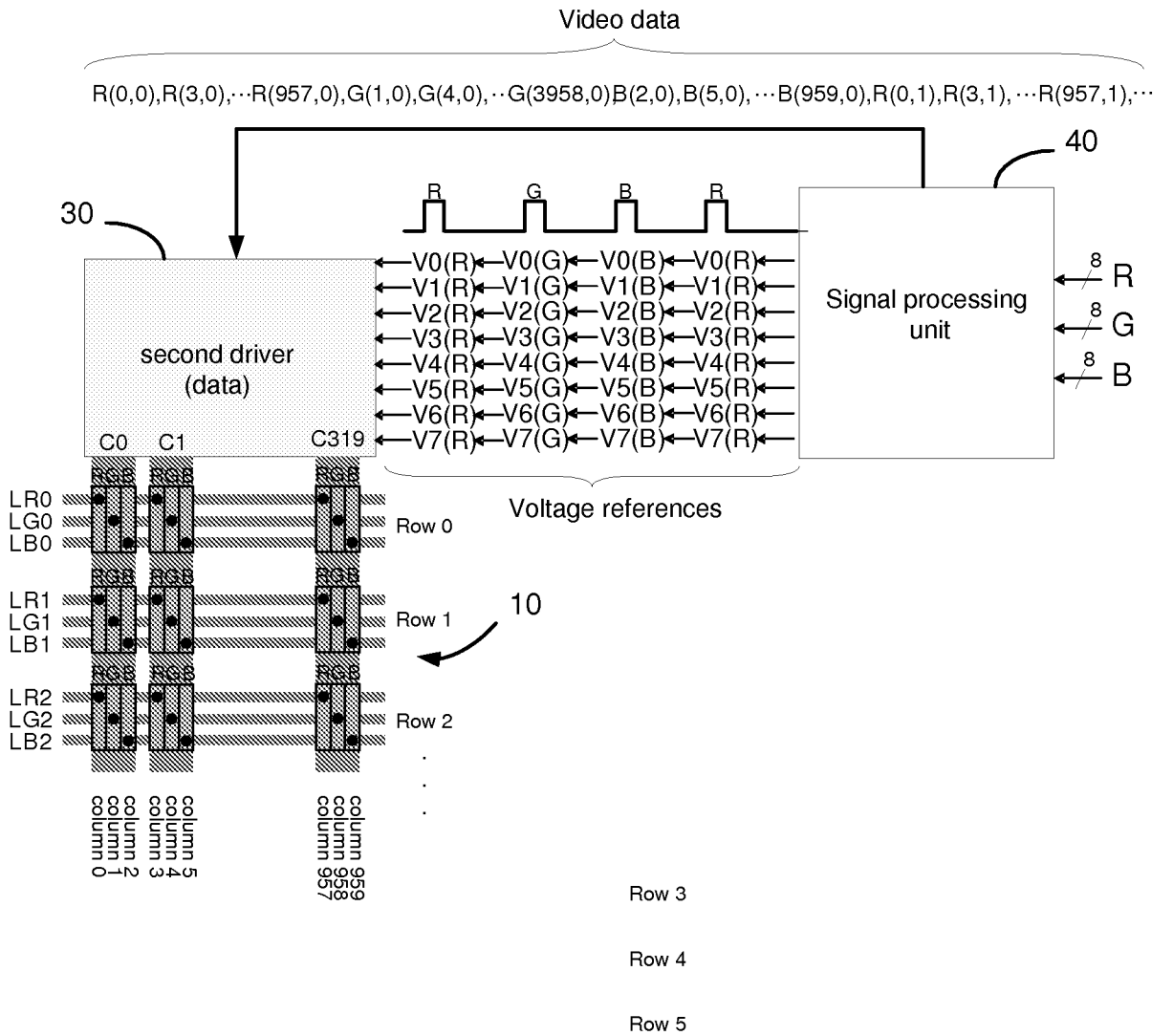

FIG.18

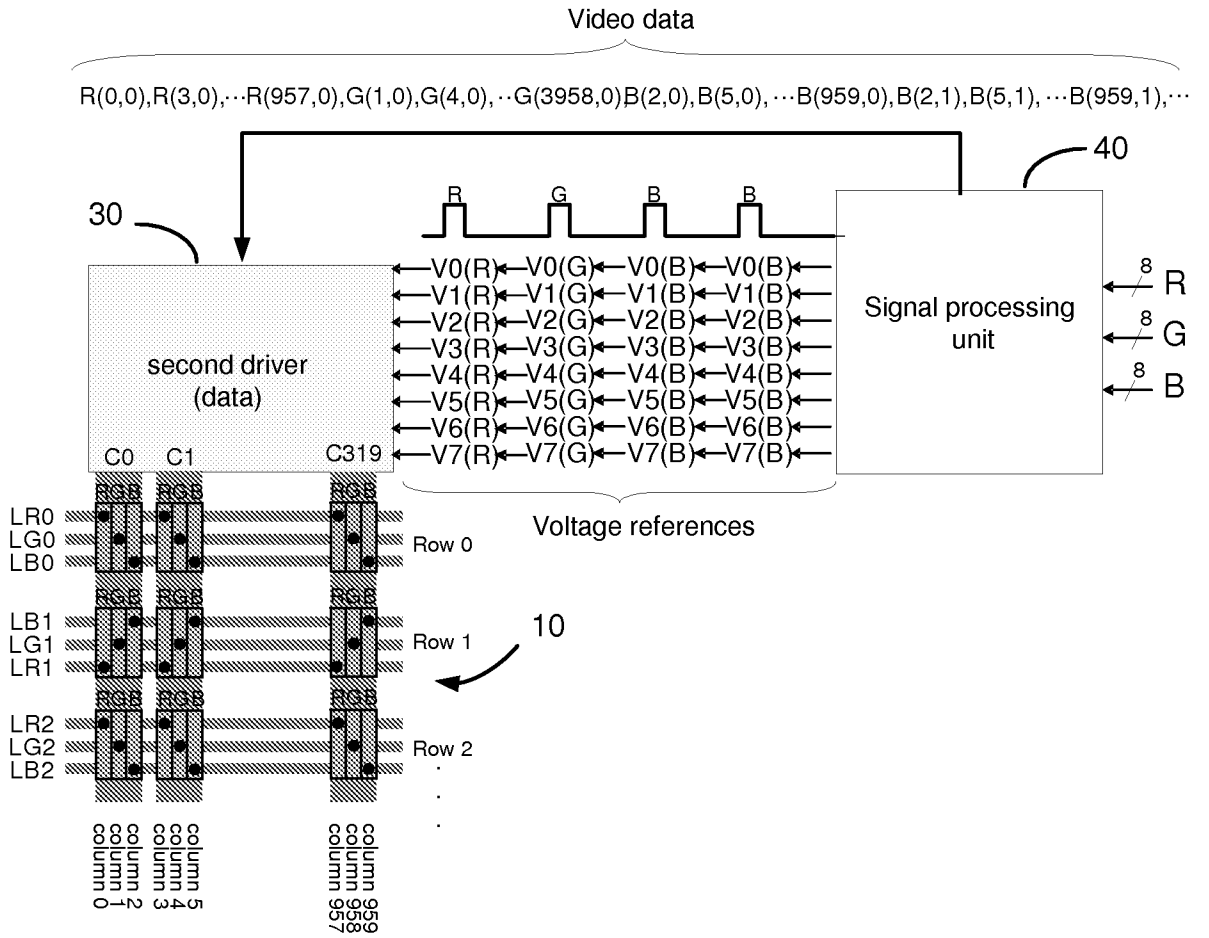

FIG.19

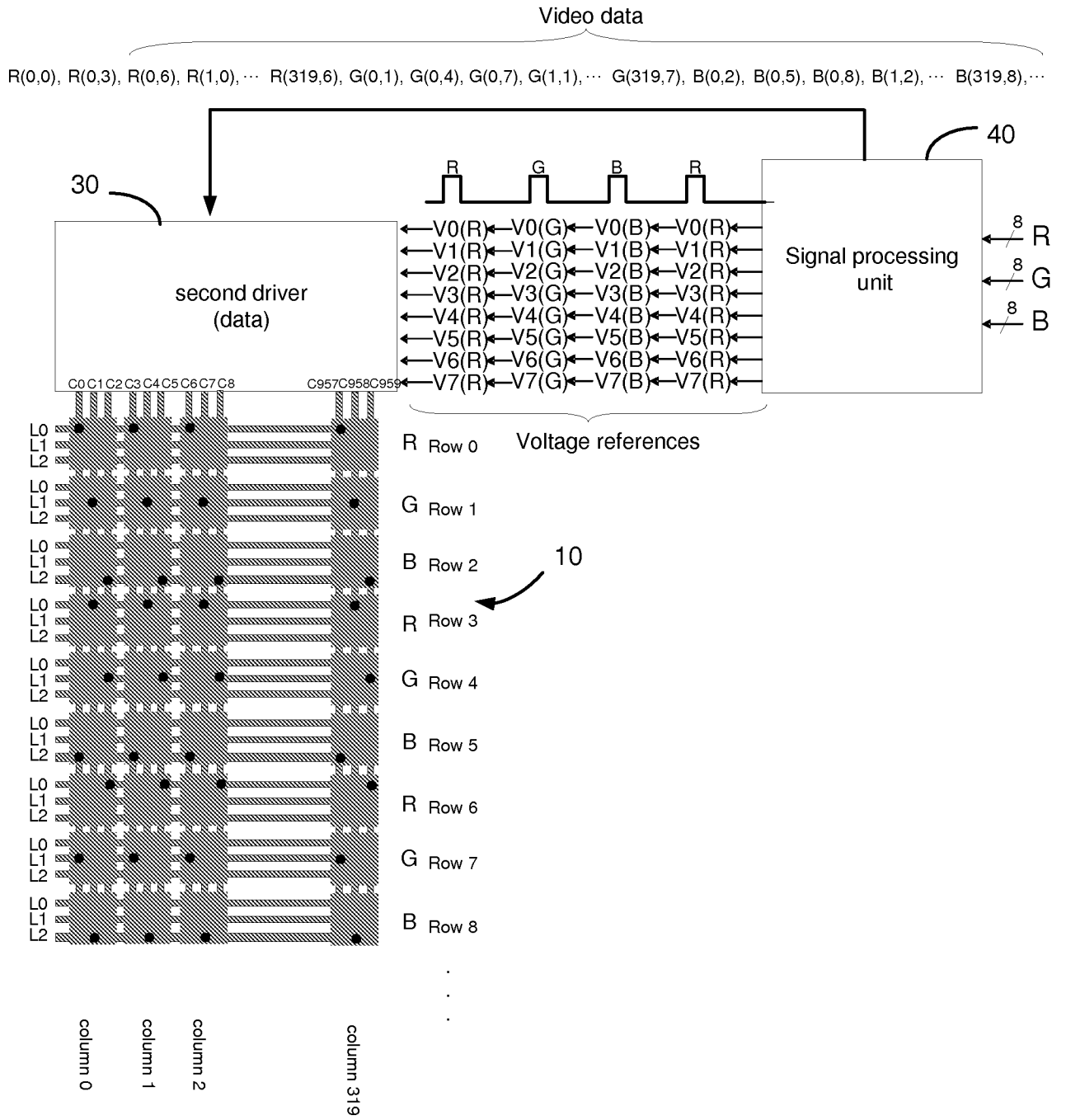

FIG.20

INTERNATIONAL SEARCH REPORT

International application No
PCT/EP2007/056385A. CLASSIFICATION OF SUBJECT MATTER
INV. G09G3/32

According to International Patent Classification (IPC) or to both national classification and IPC

B. FIELDS SEARCHED

Minimum documentation searched (classification system followed by classification symbols)
G09G H01L

Documentation searched other than minimum documentation to the extent that such documents are included in the fields searched

Electronic data base consulted during the international search (name of data base and, where practical, search terms used)

EPO-Internal, WPI Data, PAJ

C. DOCUMENTS CONSIDERED TO BE RELEVANT

Category*	Citation of document, with indication, where appropriate, of the relevant passages	Relevant to claim No.
X	EP 1 291 841 A (SEIKO EPSON CORP [JP]) 12 March 2003 (2003-03-12) paragraphs [0001], [0047], [0049], [0086], [0087], [0091], [0092] paragraphs [0133] - [0154] figures 6,10	1-3,9,12
A	US 2003/043132 A1 (NAKAMURA NORIO [JP]) 6 March 2003 (2003-03-06) paragraphs [0035] - [0046] figures 1-3	12
X	US 2003/174106 A1 (TANADA YOSHIFUMI [JP] ET AL) 18 September 2003 (2003-09-18) paragraphs [0002], [0093] - [0104] figures 1A,1B,2A,2B	1-3,9,12

 Further documents are listed in the continuation of Box C. See patent family annex.

* Special categories of cited documents :

- *A* document defining the general state of the art which is not considered to be of particular relevance
- *E* earlier document but published on or after the international filing date
- *L* document which may throw doubts on priority claim(s) or which is cited to establish the publication date of another citation or other special reason (as specified)
- *O* document referring to an oral disclosure, use, exhibition or other means
- *P* document published prior to the international filing date, but later than the priority date claimed

- *T* later document published after the international filing date or priority date and not in conflict with the application but cited to understand the principle or theory underlying the invention
- *X* document of particular relevance; the claimed invention cannot be considered novel or cannot be considered to involve an inventive step when the document is taken alone
- *Y* document of particular relevance; the claimed invention cannot be considered to involve an inventive step when the document is combined with one or more other such documents, such combination being obvious to a person skilled in the art.
- * & * document member of the same patent family

Date of the actual completion of the international search

13 September 2007

Date of mailing of the international search report

20/09/2007

Name and mailing address of the ISA/

European Patent Office, P.B. 5818 Patentlaan 2
NL - 2280 HV Rijswijk
Tel. (+31-70) 340-2040, Tx. 31 651 epo nl,
Fax: (+31-70) 340-3016

Authorized officer

Ladiray, Olivier

INTERNATIONAL SEARCH REPORT

Information on patent family members

International application No PCT/EP 2007/056385

Patent document cited in search report	Publication date	Patent family member(s)	Publication date	
EP 1291841	A	12-03-2003	CN 1405750 A	26-03-2003
			CN 1645460 A	27-07-2005
			JP 2004054188 A	19-02-2004
			KR 20030022693 A	17-03-2003
			TW 571273 B	11-01-2004
			US 2003062844 A1	03-04-2003
US 2003043132	A1	06-03-2003	JP 2003157051 A	30-05-2003
			KR 20030020832 A	10-03-2003
			TW 558700 B	21-10-2003
US 2003174106	A1	18-09-2003	CN 1450509 A	22-10-2003
			JP 3957535 B2	15-08-2007
			JP 2003271100 A	25-09-2003

专利名称(译)	有源矩阵有机发光显示器 (amoled) 器件		
公开(公告)号	EP2036069A1	公开(公告)日	2009-03-18
申请号	EP2007765645	申请日	2007-06-26
[标]申请(专利权)人(译)	汤姆森特许公司		
申请(专利权)人(译)	汤姆森许可		
当前申请(专利权)人(译)	汤姆森许可		
[标]发明人	WEITBRUCH SEBASTIEN DOSER INGO THIEBAUD SYLVAIN		
发明人	WEITBRUCH, SÉBASTIEN DOSER, INGO THIEBAUD, SYLVAIN		
IPC分类号	G09G3/32 G09G3/3225 G09G3/3233 G09G3/3266 G09G3/3291		
CPC分类号	G09G3/3225 G09G3/3233 G09G3/3266 G09G3/3291 G09G2300/0452 G09G2300/0842 G09G2320/0271		
代理机构(译)	KURTH迪特尔		
优先权	2006300737 2006-06-30 EP		
外部链接	Espacenet		

摘要(译)

有源矩阵OLED (有机发光显示器) 装置本发明涉及有源矩阵OLED (有机发光显示器) 装置。它包括与不同颜色成分 (红色 , 绿色 , 蓝色) 相关的发光元素矩阵。根据本发明 , 行驱动器 (20) 和/或数据驱动器 (30) 与矩阵的发光元件的连接被修改。行驱动器的每个输出连接到与相同颜色分量 (红色或绿色或蓝色) 相关联的发光元件。