

(19) World Intellectual Property Organization
International Bureau



(43) International Publication Date
23 October 2003 (23.10.2003)

PCT

(10) International Publication Number
WO 03/088199 A1

- (51) International Patent Classification⁷: G09G 3/32
- (21) International Application Number: PCT/IB03/01338
- (22) International Filing Date: 1 April 2003 (01.04.2003)
- (25) Filing Language: English
- (26) Publication Language: English
- (30) Priority Data:
0208656.9 16 April 2002 (16.04.2002) GB

(74) Agent: WILLIAMSON, Paul, L.; Philips Intellectual Property & Standards, Cross Oak Lane, Redhill, Surrey RH1 5HA (GB).

(71) Applicant (for all designated States except US): KONINKLIJKE PHILIPS ELECTRONICS N.V. [NL/NL]; Groenewoudseweg 1, NL-5621 BA Eindhoven (NL).

(81) Designated States (national): AE, AG, AL, AM, AT, AU, AZ, BA, BB, BG, BR, BY, BZ, CA, CH, CN, CO, CR, CU, CZ, DE, DK, DM, DZ, EC, EE, ES, FI, GB, GD, GE, GH, GM, HR, HU, ID, IL, IN, IS, JP, KE, KG, KP, KR, KZ, LC, LK, LR, LS, LT, LU, LV, MA, MD, MG, MK, MN, MW, MX, MZ, NO, NZ, OM, PH, PL, PT, RO, RU, SC, SD, SE, SG, SK, SL, TJ, TM, TN, TR, TT, TZ, UA, UG, US, UZ, VC, VN, YU, ZA, ZM, ZW.

(72) Inventors; and

(75) Inventors/Applicants (for US only): LIFKA, Herbert [AT/NL]; c/o Philips Intellectual Property & Standards, Cross Oak Lane, Redhill, Surrey RH1 5HA (GB). CHILDS, Mark, J. [GB/GB]; c/o Philips Intellectual Property & Standards, Cross Oak Lane, Redhill, Surrey RH1 5HA (GB). JOHNSON, Mark, J. [GB/GB]; c/o Philips Intellectual Property & Standards, Cross Oak Lane, Redhill, Surrey RH1 5HA (GB).

(84) Designated States (regional): ARIPO patent (GH, GM, KE, LS, MW, MZ, SD, SL, SZ, TZ, UG, ZM, ZW), Eurasian patent (AM, AZ, BY, KG, KZ, MD, RU, TJ, TM), European patent (AT, BE, BG, CH, CY, CZ, DE, DK, EE, ES, FI, FR, GB, GR, HU, IE, IT, LU, MC, NL, PT, RO, SE, SI, SK, TR), OAPI patent (BF, BJ, CF, CG, CI, CM, GA, GN, GQ, GW, ML, MR, NE, SN, TD, TG).

Published:
— with international search report

[Continued on next page]

(54) Title: ACTIVE MATRIX ELECTROLUMINESCENT DISPLAY

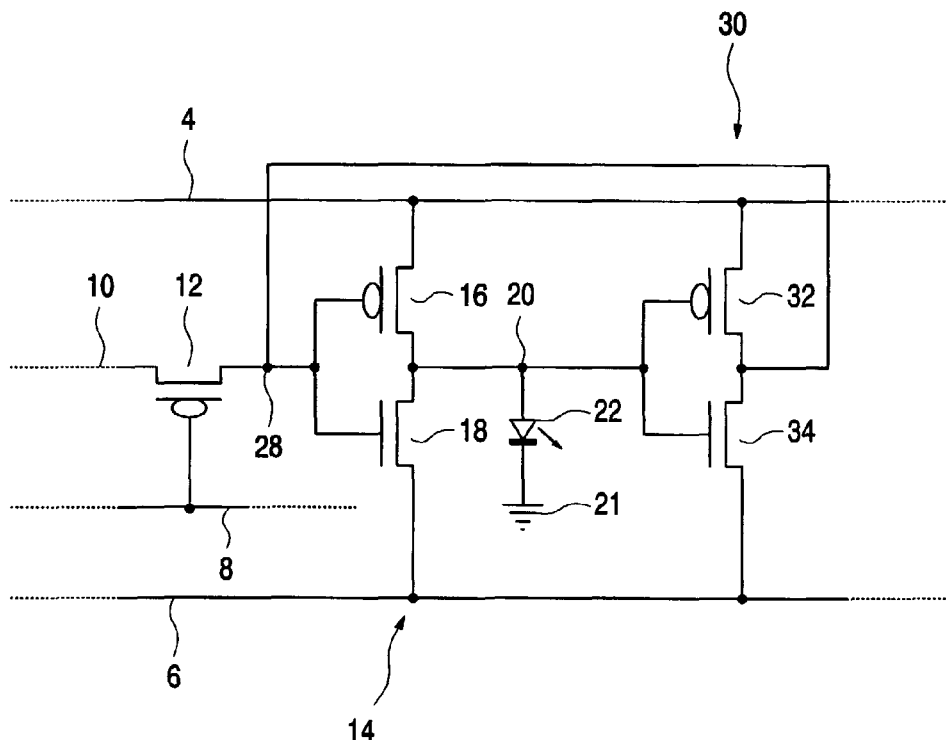

(57) Abstract: Drive circuitry for a display includes a two-transistor inverter 14, 30 within the circuitry for driving display element 22, which may be an organic light emitting diode. Embodiments include feedback to input node 28.



WO 03/088199 A1



For two-letter codes and other abbreviations, refer to the "Guidance Notes on Codes and Abbreviations" appearing at the beginning of each regular issue of the PCT Gazette.

DESCRIPTION

ACTIVE MATRIX ELECTROLUMINESCENT DISPLAY

5

The invention relates to electroluminescent display devices, for example using organic LED devices such as polymer LEDs.

10 Matrix display devices employing electroluminescent, light-emitting, display elements are well known. The display elements may comprise organic thin film electroluminescent elements, for example using polymer materials, or else light emitting diodes (LEDs) using traditional III-V semiconductor compounds. Recent developments in organic electroluminescent materials, particularly polymer materials, have demonstrated their ability to be used
15 practically for video display devices. These materials typically comprise one or more layers of a semiconducting conjugated polymer sandwiched between a pair of electrodes, one of which is transparent and the other of which is of a material suitable for injecting holes or electrons into the polymer layer. The organic material can be fabricated using a CVD process, or simply by a spin
20 coating technique using a solution of a soluble conjugated polymer. Organic electroluminescent materials exhibit diode-like I-V properties, so that they are capable of providing both a display function and a switching function, and can therefore be used in passive type displays. Alternatively, these materials may
25 be used for active matrix display devices, with each pixel comprising a display element and a switching device for controlling the current through the display element.

Organic electroluminescent materials offer advantages in that they are very efficient and require relatively low (DC) drive voltages. Moreover, in
30 contrast to conventional LCDs, no backlight is required.

Display devices of this type have current-addressed display elements, so that a conventional, analogue drive scheme involves supplying a

controllable current to the display element. It is known to provide a current source transistor as part of the pixel configuration, with the gate voltage supplied to the current source transistor determining the current through the display element. A storage capacitor holds the gate voltage after the addressing phase. In a similar manner, a digitally addressed display device can be realised by setting the current source transistor to a single (high) current level, or by preventing current flowing by making the current source transistor non-conducting.

In this way, the display elements are integrated into an active matrix, whereby each display element has an associated switching circuit which is operable to supply a drive current to the display element so as to maintain its light output for a significantly longer period than the row address period. Thus, for example, each display element circuit is loaded with an analogue (display data) drive signal once per field period in a respective row address period, which drive signal is stored and is effective to maintain a required drive current through the display element for a field period until the row of display elements concerned is next addressed.

An example of such an active matrix addressed electroluminescent display device is described in EP-A-0717446. The conventional kind of active matrix circuitry used in LCDs cannot be used with electroluminescent display elements as such display elements need to continuously pass current in order to generate light whereas the LC display elements are capacitive and therefore take virtually no current and allow the drive signal voltage to be stored in the capacitance for the whole field period. In EP-A-0717446, each switching circuit comprises two TFTs (thin film transistors) and a storage capacitor. The anode of the display element is connected to the drain of the second TFT and the first TFT is connected to the gate of the second TFT which is connected also to one side of the capacitor. During a row address period, the first TFT is turned on by means of a row selection (gating) signal and a drive (data) signal is transferred via this TFT to the capacitor. The data signal may be either analogue or digital in nature.

After the removal of the selection signal the first TFT turns off and the voltage stored on the capacitor, constituting a gate voltage for the second TFT, is responsible for operation of the second TFT which is arranged to deliver electrical current to the display element. The gate of the first TFT is connected to a gate line (row conductor) common to all display elements in the same row and the source of the first TFT is connected to a source line (column conductor) common to all display elements in the same column. The drain and source electrodes of the second TFT are connected to the anode of the display element and a ground line which extends parallel to the source line and is common to all display elements in the same column. The other side of the capacitor is also connected to this ground line.

The active matrix structure is fabricated on a suitable transparent, insulating, support, for example of glass, using thin film deposition and process technology similar to that used in the manufacture of AMLCDs.

With this arrangement, the drive current for the light-emitting diode display element is determined by a voltage applied to the gate of the second TFT. This current therefore depends strongly on the characteristics of that TFT. Variations in threshold voltage, mobility and dimensions of the TFT will produce unwanted variations in the display element current, and hence its light output. Such variations in the second TFTs associated with display elements over the area of the array, or between different arrays, due, for example, to manufacturing processes, lead to non-uniformity of light outputs from the display elements.

In order to address this issue, digital driving options have been proposed, whereby the pixel is operated by either setting the brightness to a maximum value for a given drive voltage (digital "on") or by preventing current flow (digital "off"). Grey levels are typically generated by using either time-ratio or area-ratio methods known from the prior art.

However, the known digital pixel circuits still require storage capacitors which act as the memory element that stores a voltage. Due to leakage in the pixel the stored voltage value tends to drift and this can detract from the performance of the circuit.

Further, the capacitors tend to be large and reduce the aperture of the pixel.

In addition, the gate voltage stored as a result of the current sampling operation can be subject to variation as a result of TFT parasitic capacitances.

5 This effect is known as "kick back".

A further issue with the prior art pixels is that it takes a long time to charge the storage capacitors, preventing rapid addressing of the pixels. This makes it difficult to successfully apply the time-ratio grey scale approach, as short addressing times are difficult to realise.

10 Thus, there remains a need for an improved display device addressing some or all of these issues.

According to a first aspect of the invention there is provided an active matrix display, including a display element for producing a visual output when
15 the display element is driven with a constant current; and drive circuitry for controllably driving a substantially constant current through the display element, the drive circuitry including a two transistor inverter having an inverter input and a common node output, wherein the common node output of the inverter is connected, directly or indirectly, to supply or control the current
20 passing through the corresponding display element.

By providing an inverter having a pair of transistors, the voltage on the common node output is held by one of the transistors in each state; the common node is not free to oscillate in voltage. This greatly reduces kick back.

25 The display element may conveniently be an organic light emitting diode.

The display may include a plurality of data lines for carrying a digital signal; a plurality of address lines; and the drive circuitry of each pixel may include an input node and an address transistor for inputting a digital signal to
30 the input node, the address transistor being connected to one of the address lines, one of the data lines, and the input node. Thus, the display may be addressed digitally.

According to another aspect of the invention, there is provided an active matrix display, comprising an array of pixels arranged in rows and columns, wherein each pixel includes: an organic light emitting diode display element connected to a drive node; an address transistor connected between a data
5 line and an input node, the address transistor having a control terminal connected to an address line; a drive transistor connected between a first power line and the drive node to drive the organic light emitting diode, the drive transistor being controlled for inverting operation by the input node; and a feedback inverter having its input connected to the drive node and its output
10 connected to the input node.

The drive circuitry thus functions as a memory that retains data without the need for refreshing. Thus, there is no need for a refresh cycle until the data is changed. This can save power.

The feedback loop ensures stability and, as it provides a memory
15 function, allows storage capacitors to be omitted. This may allow a reduction in the circuit area required for the circuitry in each pixel. The display may further comprise a discharge transistor of opposite conductivity type to the drive transistor connected between the drive node and a second power line, the discharge capacitor and the drive transistor forming an inverter. In such an
20 arrangement, the kick-back is virtually zero.

The feedback inverter is conveniently formed by a charge transistor connected between the first power line and a common node, and a discharge transistor of opposite conductivity type to the charge transistor connected
25 between the common node and a second power line.

A single common line preferably constitutes a power line of one row and the address line of an adjacent row. This sharing of one line to have two
30 functions increases the aperture of the display and eases manufacture by reducing the number of row lines required across the display.

The address transistor may be a p-type transistor, and the common line
30 may be the high power line of one row and the address line of an adjacent row. Alternatively, the address transistor may be an n-type transistor, and

common line may be the low power line of one row and the address line of an adjacent row.

In another aspect, the invention proposes an active matrix display, comprising an array of pixels arranged in rows and columns, wherein each pixel includes: an organic light emitting diode display element connected to a drive node; an address transistor connected between a data line and an input node, the address transistor having a control terminal connected to an address line; a drive transistor connected between a first power line and the drive node to drive the organic light emitting diode; and a discharge transistor of opposite conductivity type to the drive transistor connected between the drive node and a second power line, the discharge capacitor and the drive transistor forming an inverter controlled by the input node.

In a further aspect, the invention includes a method of driving an active matrix display including a plurality of pixels each with drive circuitry including a drive transistor and an inverter and a display element, the method including the steps of: addressing the pixels in turn; supplying digital data to the addressed pixels; controlling a drive transistor in inverting operation with the signal on the input node to drive a controllable constant current through the display element; and feeding back the voltage driving the display element through an inverter to the input node.

Embodiments of the invention will now be described, purely by way of example, with reference to the accompanying drawings, in which:

Figure 1 shows a circuit diagram of a single pixel of a first embodiment of the invention.

Figure 2 shows a circuit diagram of a single pixel of a second embodiment of the invention.

Figure 3 shows a circuit diagram of a single pixel of a third embodiment of the invention.

Figure 4 shows a circuit diagram of a single pixel of a fourth embodiment of the invention.

Figure 5 shows a circuit diagram of a fifth embodiment of the invention;

Figure 6 shows a circuit diagram of a sixth embodiment of the invention;
and

Figure 7 shows a schematic diagram of a complete display.

The same reference numbers are used throughout the figures to denote
5 the same or similar parts.

Figure 1 shows a single pixel element 2 of a polymer light emitting diode
array according to the invention.

The pixel element is supplied by power line 4 and earth line 6. Address
10 line 8 and data line 10 also feed into the pixel.

Drive circuitry includes address thin-film transistor (TFT) 12 which acts
as an addressing element which when switched on allows data to be placed
on the pixel from data line 10. In the illustrated embodiment, address TFT 12
is a p-type transistor, but the skilled person will appreciate that n-type
15 transistors can be used also.

A two-transistor inverter 14 is constituted by two TFTs, a charge TFT 16
and a discharge TFT 18 connected in series between the power line 4 and the
earth line 6. The charge TFT 16 is a p-type TFT connected between positive
power line 4 and drive node 20, and the discharge TFT 18 is an n-type TFT
20 between the drive node 20 and the earth line 6. The gates 24 of TFTs 16 and
18 are connected in common to input node 28 which is connected to the
output of addressing TFT 12.

A polymer light emitting diode (PLED) 22 display element is connected
between drive node 20 and earth 21.

25 In use, the drive circuitry switches between an "on" and an "off" mode.
In the "on" mode, PLED 22 is driven with a constant current by the drive
circuitry to switch the PLED on and emit light.

In more detail, address line 8 is pulled low to switch on addressing TFT
12 and allow the signal on the data line 10 to be passed through to input 28 of
30 the inverter 14. When the input 28 is high, discharge TFT 18 is switched on
pulling node 20 low and so switching off the PLED 22. Conversely, when input

28 is low discharge TFT 18 is switched off and charge TFT 16 switched on to pull node 20 high and drive LED 22.

The data signal is stored on the parasitic capacitance of the gates 24 of the inverter TFTs 16,18 even after the address line 8 goes high. The parasitic capacitance is great enough to retain the state of the inverter until the pixel is addressed again.

The area required for the pixel drive inverter is much less than is conventionally needed for a capacitor.

Figure 2 illustrates a second embodiment that differs from the arrangement shown in Figure 1 in that a storage capacitor 26 is provided between the input node 28 of the address TFT 12 and the power line 4. In this arrangement, the storage capacitor 26 can be much smaller than in prior arrangements in which a storage capacitor alone has to drive a a single transistor driving the LED.

Figure 3 illustrates a further embodiment of the basic design which adds a second two-transistor feedback inverter 30 having a charge TFT 32 and a discharge TFT 34. The input of the second inverter is connected to drive node 20 and the output to node 28, the input to the first inverter 14. Thus, the second inverter 30 acts as a feedback device.

In use, the two inverters 14,30 hold the state of the pixel actively, so that the pixel will remain in its state indefinitely. There is virtually no kick back in this configuration.

The pixel stability is enhanced over prior approaches that simply use a capacitance to store data.

The drive circuitry is very fast, principally because there is no large capacitance to charge. Thus, the drive circuitry is highly suitable for driving the cell at different on/off time ratios to deliver different grey values, especially low grey values. In these drive schemes, the power required to drive the pixel may be reduced.

Figure 4 illustrates a further variation, similar to that of Figure 3 except that first discharge transistor 18 is omitted. The result is that the first stage no longer has a discharge TFT 18 for fully switching off PLED 22. In the

arrangement of Figure 4 this effect is achieved by discharge transistor 34. The discharge TFT 34 of the feedback inverter 30 pulls down the input node 28 switching off the drive TFT 16 hard.

It will be noted that a feature of all of the above embodiments is the need to provide a separate power and earth line to each pixel because the PLED ground 21 is not available to act as the low power supply for the inverter or inverters. Figures 5 and 6 illustrate fifth and sixth embodiments of the invention in which the address line is shared with an inverter power line of an adjacent row, therefore reducing the number of row lines by one.

In Figure 5, common line 50 is connected as the high power supply 4 for inverters 14,30 of row 52. The common line is also connected to the gate of p-type address TFTs 12 of the preceding row 54.

In use, common line 50 acts as the power line for one row 52 of pixels and the address line for the preceding row 54. Thus, common line 50 acts as the power line powering inverters 14,30 of row 52 when it is high, but when it is low it switches on TFT 12 of the preceding row 54 to select that row. Since adjacent rows are not selected at the same time, there is no conflict between the dual roles of common line 50.

Figure 6 illustrates a similar arrangement in a n-type addressing scheme. In this case, common line 60 is connected as the low power supply 6 for inverters 14,30 of row 52. The common line is also connected to the gate of n-type address TFT 12 of the preceding row 54.

In use, common line 60 acts as the low power line for one row 52 of pixels and the address line for the preceding row 54. Thus, common line 50 acts as the low power line powering inverters 14,30 of row 52 when it is low, but when it is high it switches on TFT 12 of the preceding row 54 to select that row.

As illustrated in Figure 7, a plurality of pixels 2 are arranged in a plurality of rows 70 and columns 72 to form a complete active matrix electroluminescent display. Data lines 10 run in the column direction.

The example of Figure 7 illustrates the arrangement of a complete electroluminescent display according to the embodiment of Figure 5, in which

common power and address lines 50, and low power lines 6 run in the row direction. Column driver 74 drives the data lines 10, and row driver 76 drives the address lines 50,6. It will readily be appreciated that similar complete displays may be made using the arrangements of embodiments 1 to 4 by
5 providing separate high and low power lines 4, 6 and address lines 8 running in the row direction.

From reading the present disclosure, other variations and modifications will be apparent to persons skilled in the art. Such variations and modifications may involve equivalent and other features which are already known in the
10 design, manufacture and use of displays and which may be used in addition to or instead of features described herein.

For example, the polymer light emitting diode may be replaced by an alternative organic light emitting diode, as will be well known to those skilled in the art. In addition, other active matrix displays which work on the principle of a
15 pixel circuit supplying a substantially constant current during the operation period can be beneficially driven using drive circuitry according to the invention. Examples of such display principles are field emission displays, electrochromic displays, switching mirror displays, displays with local pixel oscillators etc.

CLAIMS

1. An active matrix display, comprising an array of pixels (2) arranged in rows and columns,
5 wherein each pixel includes:
 a display element (22) for producing a visual output when the display element is driven with a constant current; and
 drive circuitry for controllably driving a substantially constant current through the display element, the drive circuitry including a two transistor
10 inverter (14, 30) having an inverter input (28) and a common node output (20),
 wherein the common node output of the inverter is connected, directly or indirectly, to supply or control the current passing through the corresponding display element.

- 15 2. An active matrix display according to claim 1 wherein the display element (22) is an organic light emitting diode.

3. An active matrix display according to claim 1 or 2 further comprising:
 a plurality of data lines (10) for carrying a digital signal;
20 a plurality of address lines (8);
 wherein the drive circuitry of each pixel comprises an input node (28) and an address transistor (12) for inputting a digital signal to the input node, the address transistor being connected to one of the address lines (8), one of the data lines (10), and the input node (28).

- 25 4. An active matrix display according to claim 3,
 wherein:
 the drive circuitry includes a drive transistor (16) connected between a first power (4) line and a drive node (20) to drive the display element (22), the
30 drive transistor being controlled for inverting operation by the input node (28);
 and

the inverter (30) is a feedback inverter having its input connected to the drive node and its common node output connected to the input node.

5. An active matrix display according to claim 4 further comprising a discharge transistor (18) of opposite conductivity type to the drive transistor (16) connected between the drive node (20) and a second power line (6), the discharge transistor and the drive transistor (16) forming an inverter (14).
6. A active matrix display according to claims 3, 4, or 5 wherein the common node (20) is connected to drive the display element and the input of the inverter is connected to the input node.
7. An active matrix display according to any of claims 3, 4, 5 or 6 wherein a single common line (50, 60) constitutes a power line of one row and the address line of an adjacent row.
8. An active matrix display according to claim 7 wherein the address transistor is a p-type transistor (12), and the common line (50) is the high power line of one row and the address line of an adjacent row.
9. An active matrix display according to claim 7 when dependent on claim 3 wherein the address transistor (12) is an n-type transistor, and the common line (60) is the low power line of one row and the address line of an adjacent row.
10. A method of driving an active matrix display including a plurality of pixels (2) each with drive circuitry including a drive transistor (16) and an inverter (30) and a display element, the method including the steps of:
- addressing the pixels in turn;
 - supplying digital data to the addressed pixels;

controlling a drive transistor in inverting operation with the signal on the input node to drive a controllable constant current through the display element (22); and

5 feeding back the voltage driving the display element through an inverter to the input node.

1/5

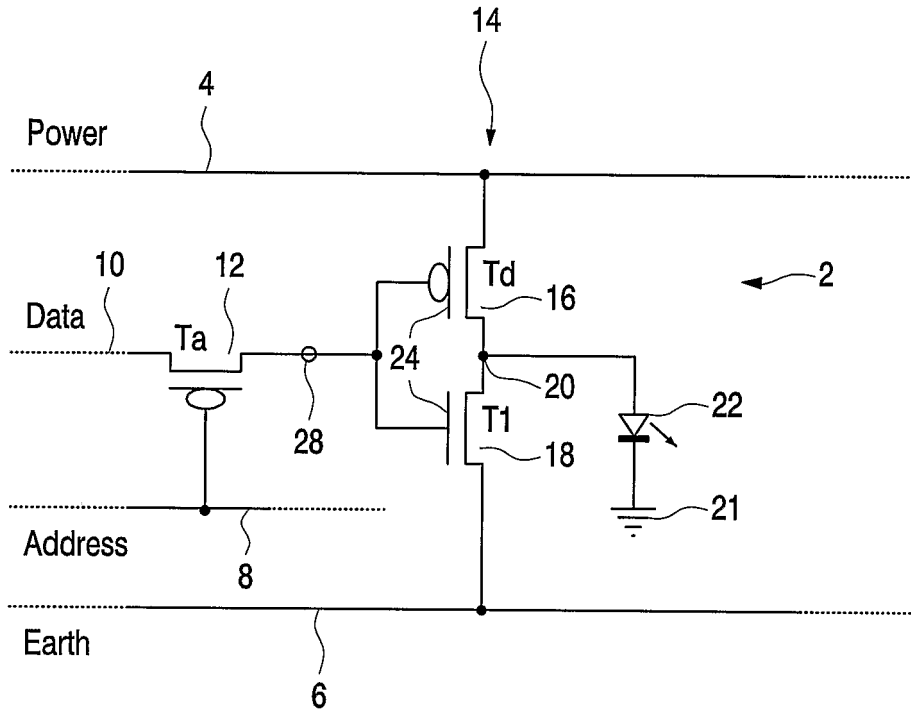

Fig.1

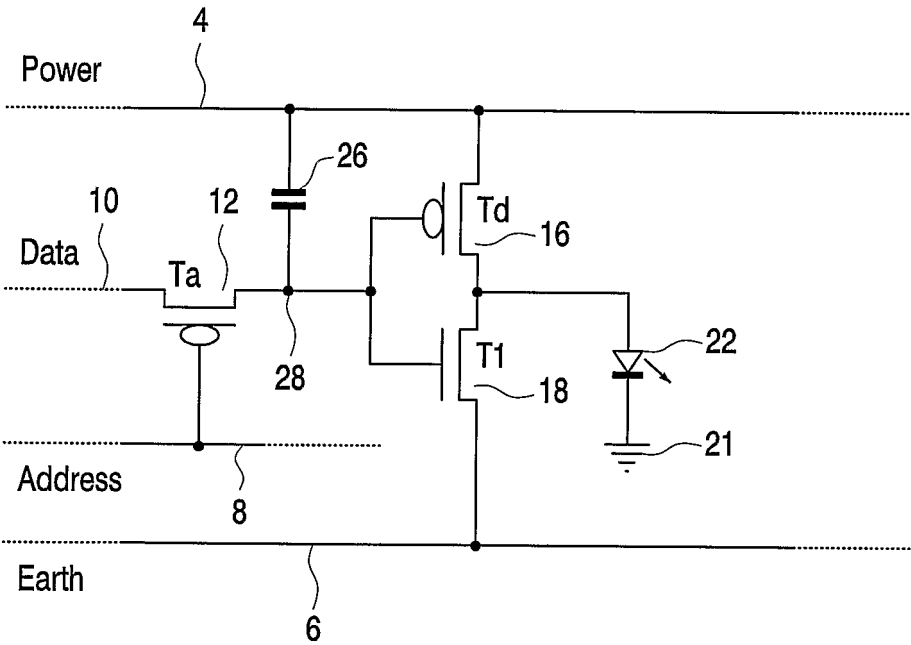

Fig.2

2/5

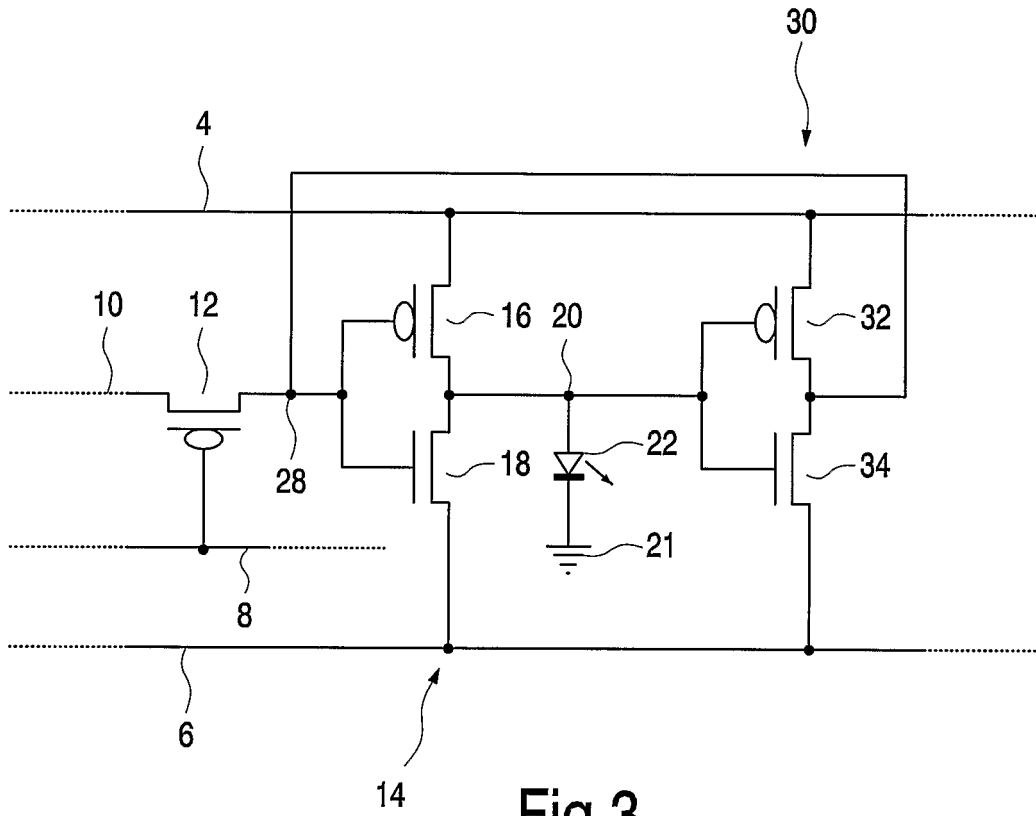

Fig.3

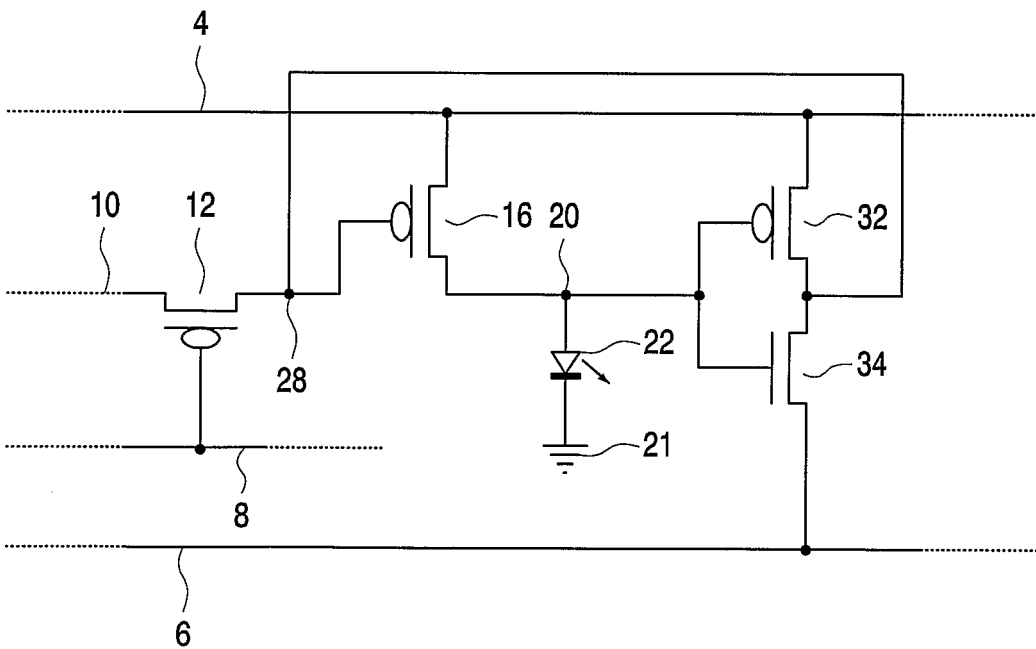

Fig.4

3/5

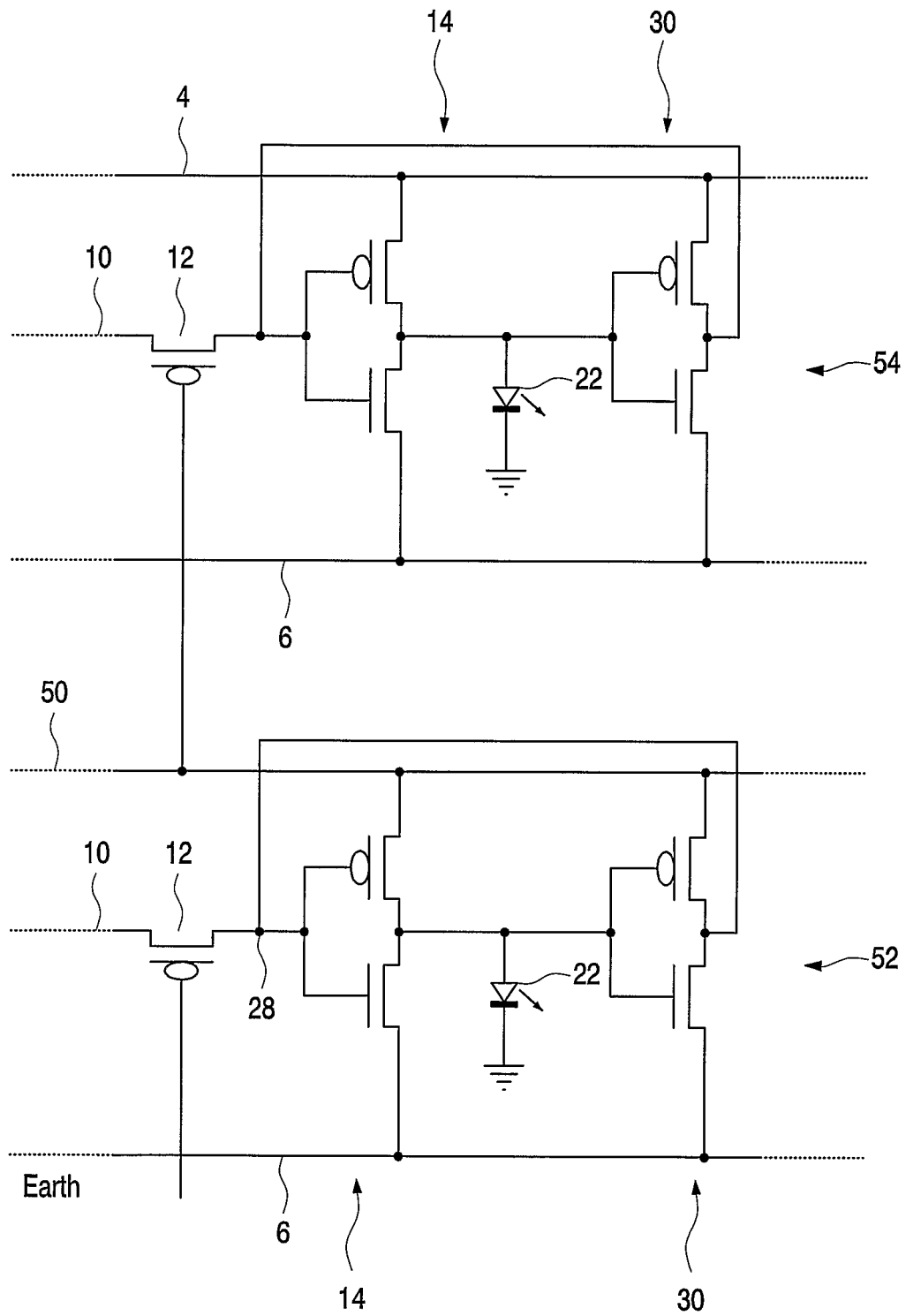

Fig.5

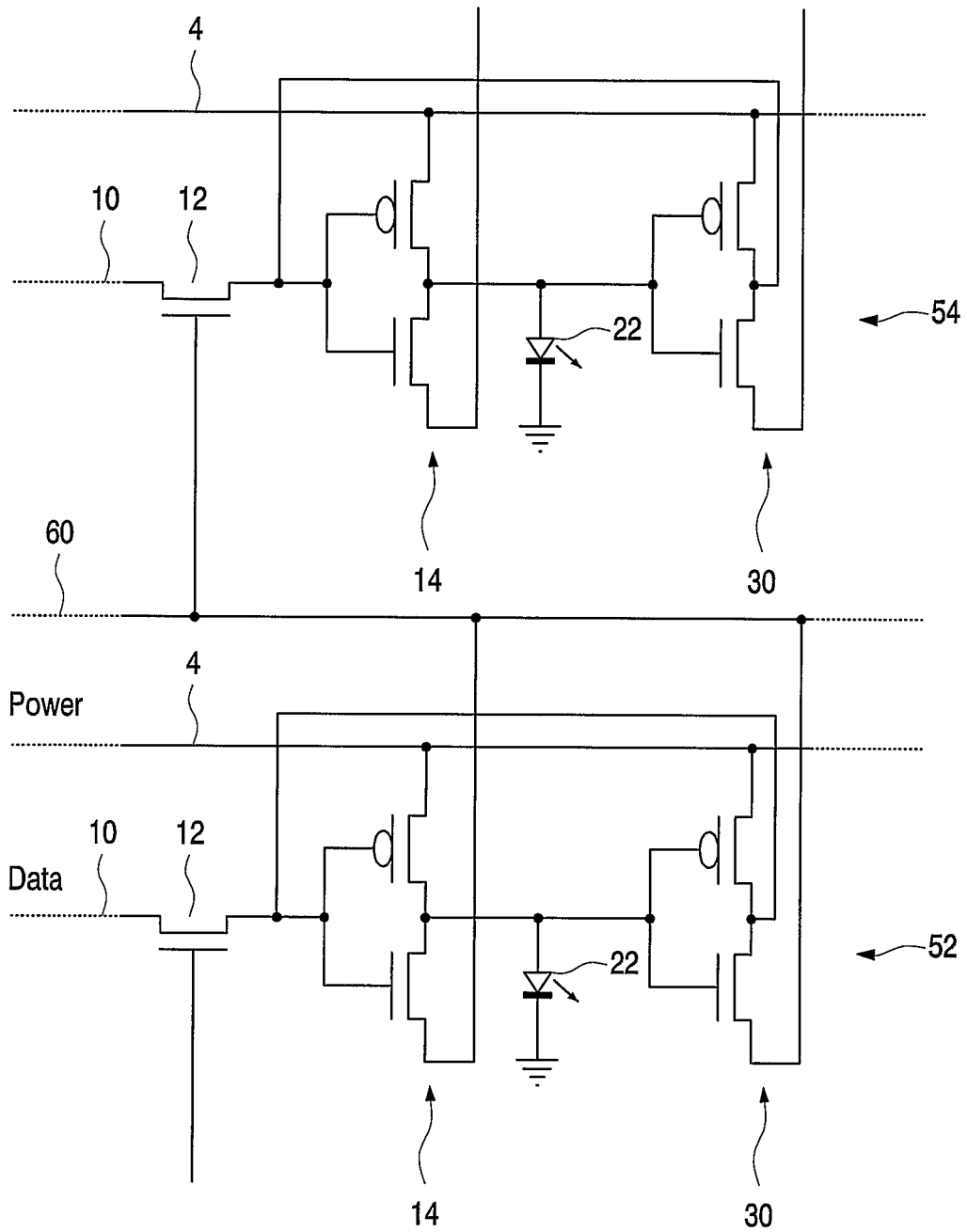

Fig.6

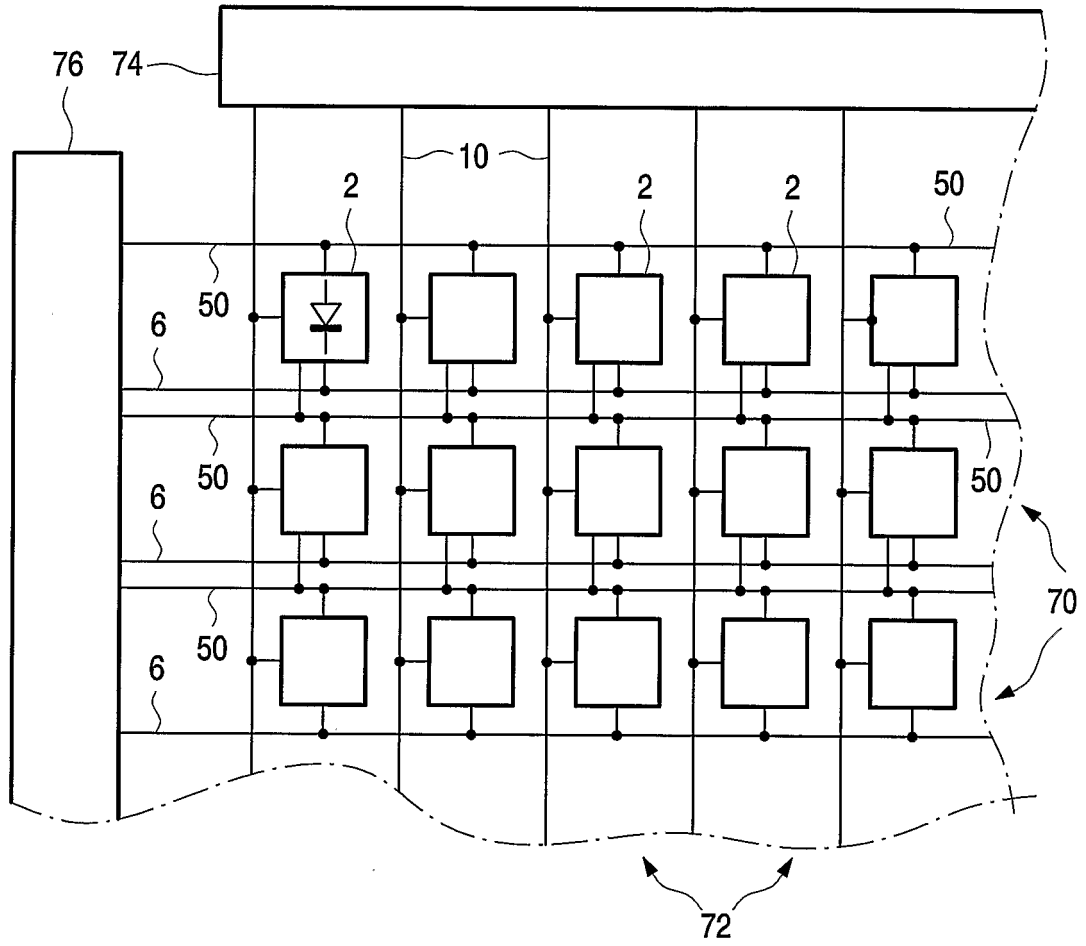

Fig.7

INTERNATIONAL SEARCH REPORT

Intern: Application No

PCT/IB 03/01338

A. CLASSIFICATION OF SUBJECT MATTER

IPC 7 G09G3/32

According to International Patent Classification (IPC) or to both national classification and IPC

B. FIELDS SEARCHED

Minimum documentation searched (classification system followed by classification symbols)

IPC 7 G09G

Documentation searched other than minimum documentation to the extent that such documents are included in the fields searched

Electronic data base consulted during the international search (name of data base and, where practical, search terms used)

EPO-Internal, PAJ, INSPEC, WPI Data

C. DOCUMENTS CONSIDERED TO BE RELEVANT

Category °	Citation of document, with indication, where appropriate, of the relevant passages	Relevant to claim No.
X Y A	US 2001/043173 A1 (TROUTMAN RONALD ROY) 22 November 2001 (2001-11-22) paragraph '0002! paragraph '0021! - paragraph '0026! figures 1,4-6 ---	1-3,6 7-9 4,10
X A	WO 02 17289 A (EMAGIN CORP) 28 February 2002 (2002-02-28) page 4, line 13 -page 6, line 21 figures 1-3 ---	1-3 4,6,10
Y	US 6 359 605 B1 (BIRD NEIL C ET AL) 19 March 2002 (2002-03-19) column 7, line 46 -column 8, line 27 figure 4 ---	7-9
	-/--	

 Further documents are listed in the continuation of box C. Patent family members are listed in annex.

° Special categories of cited documents :

- *A* document defining the general state of the art which is not considered to be of particular relevance
- *E* earlier document but published on or after the international filing date
- *L* document which may throw doubts on priority claim(s) or which is cited to establish the publication date of another citation or other special reason (as specified)
- *O* document referring to an oral disclosure, use, exhibition or other means
- *P* document published prior to the international filing date but later than the priority date claimed

- *T* later document published after the international filing date or priority date and not in conflict with the application but cited to understand the principle or theory underlying the invention
- *X* document of particular relevance; the claimed invention cannot be considered novel or cannot be considered to involve an inventive step when the document is taken alone
- *Y* document of particular relevance; the claimed invention cannot be considered to involve an inventive step when the document is combined with one or more other such documents, such combination being obvious to a person skilled in the art.
- * & * document member of the same patent family

Date of the actual completion of the international search

28 July 2003

Date of mailing of the international search report

06/08/2003

Name and mailing address of the ISA

European Patent Office, P.B. 5818 Patentlaan 2
NL - 2280 HV Rijswijk
Tel. (+31-70) 340-2040, Tx. 31 651 epo nl,
Fax: (+31-70) 340-3016

Authorized officer

Farricella, L

INTERNATIONAL SEARCH REPORT

International Application No

PCT/IB 03/01338

C.(Continuation) DOCUMENTS CONSIDERED TO BE RELEVANT

Category °	Citation of document, with indication, where appropriate, of the relevant passages	Relevant to claim No.
P, X	US 2002/140642 A1 (OKAMOTO SHIGETSUGU) 3 October 2002 (2002-10-03)	1-5, 10
P, A	paragraph '0044! - paragraph '0051! figures 1,2	6-9
A	----- EP 1 098 290 A (SEMICONDUCTOR ENERGY LAB) 9 May 2001 (2001-05-09) paragraph '0098! figure 20B	4
A	----- EP 1 182 636 A (SEMICONDUCTOR ENERGY LAB) 27 February 2002 (2002-02-27) -----	

INTERNATIONAL SEARCH REPORT

Information on patent family members

International Application No

PCT/IB 03/01338

Patent document cited in search report		Publication date	Patent family member(s)	Publication date
US 2001043173	A1	22-11-2001	NONE	
WO 0217289	A	28-02-2002	AU 8510101 A WO 0217289 A1 US 2002044110 A1	04-03-2002 28-02-2002 18-04-2002
US 6359605	B1	19-03-2002	EP 1034529 A2 WO 9965012 A2 JP 2002518691 T US 2002126073 A1	13-09-2000 16-12-1999 25-06-2002 12-09-2002
US 2002140642	A1	03-10-2002	JP 2002287695 A CN 1366344 A	04-10-2002 28-08-2002
EP 1098290	A	09-05-2001	CN 1303084 A EP 1098290 A2 JP 2001222256 A TW 484117 B	11-07-2001 09-05-2001 17-08-2001 21-04-2002
EP 1182636	A	27-02-2002	CN 1339876 A EP 1182636 A2 JP 2002140034 A US 2002036604 A1	13-03-2002 27-02-2002 17-05-2002 28-03-2002

专利名称(译)	有源矩阵电致发光显示器		
公开(公告)号	EP1500074A1	公开(公告)日	2005-01-26
申请号	EP2003712508	申请日	2003-04-01
[标]申请(专利权)人(译)	皇家飞利浦电子股份有限公司		
申请(专利权)人(译)	皇家飞利浦电子N.V.		
当前申请(专利权)人(译)	TPO DISPLAYS CORP.		
[标]发明人	LIFKA HERBERT PHILIPS INTEL PROP & STAND CHILDS MARK J PHILIPS INTEL PROP & STAND JOHNSON MARK J PHILIPS INTEL PROP & STAND		
发明人	LIFKA, HERBERT,PHILIPS INTEL. PROP. & STAND. CHILDS, MARK, J.,PHILIPS INTEL. PROP. & STAND. JOHNSON, MARK J.,PHILIPS INTEL. PROP. & STAND.		
IPC分类号	H01L51/50 G09G3/20 G09G3/30 G09G3/32		
CPC分类号	G09G3/3233 G09G3/3258 G09G2300/0465 G09G2300/0842 G09G2300/0847 G09G2300/0857 G09G2320/0233		
优先权	2002008656 2002-04-16 GB		
外部链接	Espacenet		

摘要(译)

用于显示器的驱动电路包括用于驱动显示元件22的电路内的双晶体管反相器14,30,显示元件22可以是有机发光二极管。实施例包括对输入节点28的反馈。