



(12) **EUROPEAN PATENT APPLICATION**

(43) Date of publication:  
**01.07.2020 Bulletin 2020/27**

(51) Int Cl.:  
**G09G 3/3233 (2016.01)**

(21) Application number: **19218631.0**

(22) Date of filing: **20.12.2019**

(84) Designated Contracting States:  
**AL AT BE BG CH CY CZ DE DK EE ES FI FR GB GR HR HU IE IS IT LI LT LU LV MC MK MT NL NO PL PT RO RS SE SI SK SM TR**  
 Designated Extension States:  
**BA ME**  
 Designated Validation States:  
**KH MA MD TN**

(72) Inventors:  
 • **SHIM, Joosung**  
**10845 Gyeonggi-do (KR)**  
 • **HONG, MooKyoung**  
**10845 Gyeonggi-do (KR)**

(74) Representative: **Viering, Jentschura & Partner mbB**  
**Patent- und Rechtsanwälte**  
**Am Brauhaus 8**  
**01099 Dresden (DE)**

(30) Priority: **28.12.2018 KR 20180172030**

(71) Applicant: **LG Display Co., Ltd.**  
**Seoul 07336 (KR)**

(54) **LIGHT EMITTING DISPLAY APPARATUS**

(57) Disclosed is a light emitting display apparatus which sets black image data, corresponding to a black image (BI) displayed after a normal image (I) is displayed,

for each pixel in one frame period on the basis of a characteristic of a light emitting display panel.

**FIG. 4**

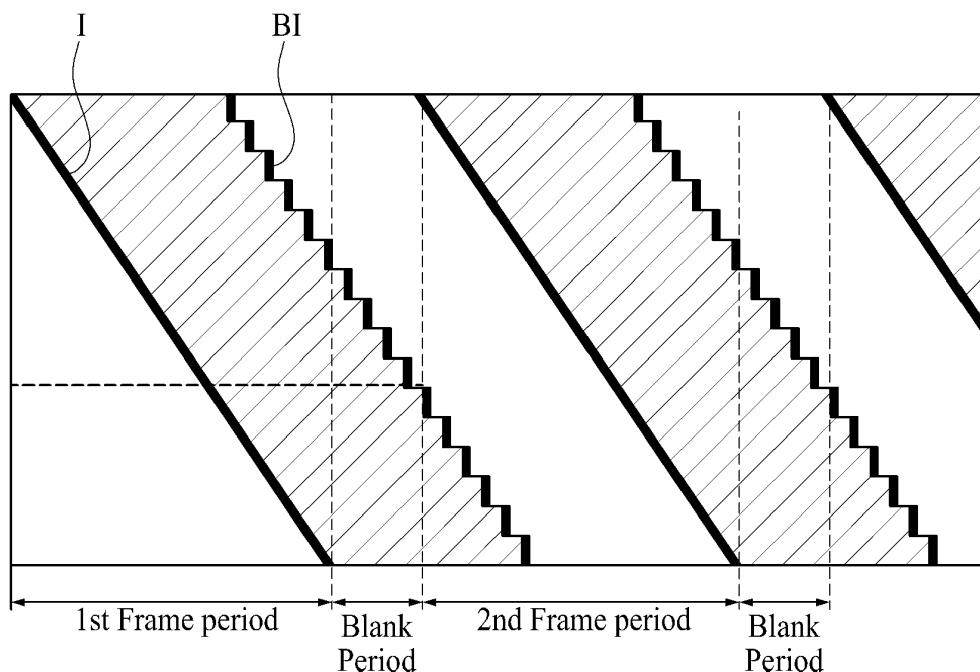

## Description

### BACKGROUND

#### Field of the Invention

[0001] The present disclosure relates to a light emitting display apparatus using a black image mode which displays an image and then displays a black image during one frame period, for improving a motion picture response time (MPRT).

#### Discussion of the Related Art

[0002] In addition to liquid crystal display (LCD) apparatuses, light emitting display apparatuses including a light emitting device such as a light emitting diode have a problem where an image is not clearly seen due to the delay of a motion picture response time (MPRT).

[0003] In order to solve such a problem, a black image mode which displays an image and then displays a black image during one frame period is used.

[0004] However, in a related art light emitting display apparatus, the same black image data voltages corresponding to a black image are supplied to all pixels.

[0005] In this case, degrees of degradation of driving transistors included in respective pixels differ, and thus, even when the same black image data voltages are supplied to all of the pixels, all of the pixels do not display the same black images. Due to this, dimming may occur in a portion of a light emitting display panel.

[0006] Moreover, when a black image data voltage is supplied to a data line, a reference voltage supplied through a reference voltage line disposed in parallel with the data line in each pixel is coupled to the black image data voltage, and due to this, is shaken (distorted). When the reference voltage is shaken, a voltage at a source of the driving transistor is shaken, and due to this, a normal image may not be displayed.

#### SUMMARY

[0007] Accordingly, the present disclosure is directed to providing a light emitting display apparatus that substantially obviates one or more problems due to limitations and disadvantages of the related art.

[0008] An aspect of the present disclosure is directed to providing a light emitting display apparatus which sets black image data, corresponding to a black image displayed after a normal image is displayed, for each pixel in one frame period on the basis of a characteristic of a light emitting display panel.

[0009] Additional advantages and features of the disclosure will be set forth in part in the description which follows and in part will become apparent to those having ordinary skill in the art upon examination of the following or may be learned from practice of the disclosure. The objectives and other advantages of the disclosure may

be realized and attained by the structure particularly pointed out in the written description and claims hereof as well as the appended drawings.

[0010] To achieve these and other advantages and in accordance with the purpose of the disclosure, as embodied and broadly described herein, there is provided a light emitting display apparatus according to claim 1. Further embodiments are defined in the dependent claims. Various embodiments provide a light emitting display apparatus including a light emitting display panel including a pixel including a light emitting device and a driving transistor driving the light emitting device, a controller setting black image data corresponding to a black image displayed through an  $n^{\text{th}}$  pixel after a normal image is displayed through the  $n^{\text{th}}$  pixel in one frame period, based on a characteristic value of the light emitting display panel, a storage unit storing the characteristic value generated from the light emitting display panel, a data driver converting pieces of black image data, transferred from the controller, into black image data voltages and outputting the black image data voltages to data lines included in the light emitting display panel, and a gate driver outputting gate signals to gate lines included in the light emitting display panel, based on control by the controller.

[0011] According to various embodiments of the present disclosure, there is provided a light emitting display apparatus comprising: a light emitting display panel including a pixel including a light emitting device and a driving transistor driving the light emitting device; a controller setting black image data corresponding to a black image displayed through an  $n^{\text{th}}$  pixel after a normal image is displayed through the  $n^{\text{th}}$  pixel in one frame period, based on a characteristic value of the light emitting display panel; a storage unit storing the characteristic value generated from the light emitting display panel; a data driver converting pieces of black image data, transferred from the controller, into black image data voltages and outputting the black image data voltages to data lines included in the light emitting display panel; and a gate driver outputting gate signals to gate lines included in the light emitting display panel, based on control by the controller, wherein the characteristic value is a threshold voltage variation amount of a driving transistor included in at least one of all pixels included in the light emitting display panel, and the controller generates the black image data corresponding to the  $n^{\text{th}}$  pixel by using the threshold voltage variation amount.

[0012] According to various embodiments, the threshold voltage variation amount applied to the  $n^{\text{th}}$  pixel is a threshold voltage variation amount of a driving transistor included in the  $n^{\text{th}}$  pixel.

[0013] According to various embodiments, the threshold voltage variation amount is generated after an apparatus turn-off signal is received from an external system, and is stored in the storage unit.

[0014] According to various embodiments, the storage unit stores a start threshold voltage measured from the

at least one pixel in a process of manufacturing the light emitting display panel and a threshold voltage which is measured from the at least one pixel after an apparatus turn-off signal is received, and the controller calculates the threshold voltage variation amount by using the start threshold voltage and the threshold voltage.

**[0015]** According to various embodiments, a black image data voltage generated by the data driver on basis of black image data corresponding to the  $n^{\text{th}}$  pixel is a voltage which varies by the threshold voltage variation amount of the at least one pixel in comparison with a reference black image data voltage applied to the all pixels included in the light emitting display panel.

**[0016]** According to various embodiments, pieces of black image data corresponding to the all pixels included in the light emitting display panel are not equal.

**[0017]** According to various embodiments, the threshold voltage variation amount applied to the  $n^{\text{th}}$  pixel is an average of threshold voltage variation amounts of at least two of all driving transistors included in the light emitting display panel.

**[0018]** According to various embodiments, the controller generates the pieces of black image data corresponding to the all pixels included in the light emitting display panel, based on the average.

**[0019]** According to various embodiments, the pieces of black image data corresponding to the all pixels included in the light emitting display panel, based on the average are equal.

**[0020]** Various embodiments provide a light emitting display apparatus comprising: a light emitting display panel including a pixel including a light emitting device and a driving transistor driving the light emitting device; a controller setting black image data corresponding to a black image displayed through an  $n^{\text{th}}$  pixel after a normal image is displayed through the  $n^{\text{th}}$  pixel in one frame period, based on a characteristic value of the light emitting display panel; a storage unit storing the characteristic value generated from the light emitting display panel; a data driver converting pieces of black image data, transferred from the controller, into black image data voltages and outputting the black image data voltages to data lines included in the light emitting display panel; and a gate driver outputting gate signals to gate lines included in the light emitting display panel, based on control by the controller, wherein the characteristic value is a minimum value among values of pieces of normal image data voltages which are output to all pixels included in the light emitting display panel in one frame period, and the controller generates the black image data by using the minimum value.

**[0021]** According to various embodiments, a black image data voltage generated by the data driver on basis of black image data corresponding to the  $n^{\text{th}}$  pixel is greater than a reference black image data voltage applied to the all pixels included in the light emitting display panel and is less than the minimum value.

**[0022]** According to various embodiments, a black image data voltage generated by the data driver on basis

of black image data corresponding to the  $n^{\text{th}}$  pixel is greater than a reference black image data voltage and is less than a predetermined highest black image data voltage.

**[0023]** According to various embodiments, when the minimum value is greater than the highest black image data voltage, the black image data voltage is the highest black image data voltage.

**[0024]** Various embodiments provide a light emitting display apparatus comprising: a light emitting display panel including a plurality of pixels respectively including a light emitting device and a driving transistor configured to drive the light emitting device; a controller configured to set black image data corresponding to a black image displayed through an  $n^{\text{th}}$  pixel after a normal image is displayed through the  $n^{\text{th}}$  pixel in one frame period, based on a characteristic value of the light emitting display panel; a storage unit configured to store the characteristic value generated from the light emitting display panel; a data driver configured to convert pieces of black image data, transferred from the controller, into black image data voltages and to output the black image data voltages to data lines included in the light emitting display panel; and a gate driver configured to output gate signals to gate lines included in the light emitting display panel, based on control by the controller.

**[0025]** According to various embodiments, the characteristic value is or includes a threshold voltage variation amount of a driving transistor included in at least one of the pixels included in the light emitting display panel, and the controller is configured to generate the black image data corresponding to the  $n^{\text{th}}$  pixel by using the threshold voltage variation amount.

**[0026]** According to various embodiments, the threshold voltage variation amount applied to the  $n^{\text{th}}$  pixel is a threshold voltage variation amount of a driving transistor included in the  $n^{\text{th}}$  pixel.

**[0027]** According to various embodiments, the threshold voltage variation amount is generated after an apparatus turn-off signal is received from an external system, and is stored in the storage unit.

**[0028]** According to various embodiments, the storage unit is configured to store a start threshold voltage measured from the at least one pixel in a process of manufacturing the light emitting display panel and a threshold voltage which is measured from the at least one pixel after an apparatus turn-off signal is received, and the controller is configured to calculate the threshold voltage variation amount by using the start threshold voltage and the threshold voltage.

**[0029]** According to various embodiments, a black image data voltage generated by the data driver on the basis of black image data corresponding to the  $n^{\text{th}}$  pixel is a voltage which varies by the threshold voltage variation amount of the at least one pixel in comparison with a reference black image data voltage applied to all the pixels included in the light emitting display panel.

**[0030]** According to various embodiments the threshold voltage variation amount applied to the  $n^{\text{th}}$  pixel is an

average of threshold voltage variation amounts of at least two of all driving transistors included in the light emitting display panel.

[0031] According to various embodiments, the controller is configured to generate the pieces of black image data corresponding to all the pixels included in the light emitting display panel, based on the average.

[0032] According to various embodiments, the pieces of black image data corresponding to all the pixels included in the light emitting display panel, based on the average, are equal.

[0033] According to various embodiments, pieces of black image data corresponding to all the pixels included in the light emitting display panel are not equal.

[0034] According to various embodiments, the characteristic value is or includes a minimum value among values of pieces of normal image data voltages which are output to all pixels included in the light emitting display panel in one frame period, and the controller is configured to generate the black image data by using the minimum value.

[0035] According to various embodiments, a black image data voltage generated by the data driver on the basis of black image data corresponding to the  $n^{\text{th}}$  pixel is greater than a reference black image data voltage applied to all the pixels included in the light emitting display panel and is less than the minimum value.

[0036] According to various embodiments, a black image data voltage generated by the data driver on the basis of black image data corresponding to the  $n^{\text{th}}$  pixel is greater than a reference black image data voltage and is less than a predetermined highest black image data voltage.

[0037] According to various embodiments, when the minimum value is greater than the highest black image data voltage, the black image data voltage is the highest black image data voltage.

[0038] It is to be understood that both the foregoing general description and the following detailed description of the present disclosure are exemplary and explanatory and are intended to provide further explanation of the disclosure as claimed.

#### **BRIEF DESCRIPTION OF THE DRAWINGS**

[0039] The accompanying drawings, which are included to provide a further understanding of the disclosure and are incorporated in and constitute a part of this application, illustrate embodiments of the disclosure and together with the description serve to explain the principle of the disclosure. In the drawings:

FIG. 1 is an exemplary diagram illustrating a configuration of a light emitting display apparatus according to the present disclosure;

FIG. 2 is an exemplary diagram illustrating a configuration of one pixel of a light emitting display apparatus according to the present disclosure;

FIG. 3 is an exemplary diagram illustrating a configuration of a controller applied to a light emitting display apparatus according to the present disclosure; FIG. 4 is an exemplary diagram illustrating a driving period of a light emitting display apparatus according to the present disclosure;

FIG. 5 is an exemplary diagram illustrating data voltages applied to a light emitting display apparatus according to the present disclosure; and

FIG. 6 is another exemplary diagram illustrating data voltages applied to a light emitting display apparatus according to the present disclosure.

#### **DETAILED DESCRIPTION OF THE DISCLOSURE**

[0040] Reference will now be made in detail to the exemplary embodiments of the present disclosure, examples of which are illustrated in the accompanying drawings. Wherever possible, the same reference numbers will be used throughout the drawings to refer to the same or like parts.

[0041] Advantages and features of the present disclosure, and implementation methods thereof will be clarified through following embodiments described with reference to the accompanying drawings. The present disclosure may, however, be embodied in different forms and should not be construed as limited to the embodiments set forth herein. Rather, these embodiments are provided so that this disclosure will be thorough and complete, and will fully convey the scope of the present disclosure to those skilled in the art. Furthermore, the present disclosure is only defined by scopes of claims.

[0042] In the specification, in adding reference numerals for elements in each drawing, it should be noted that like reference numerals already used to denote like elements in other drawings are used for elements wherever possible.

[0043] A shape, a size, a ratio, an angle, and a number disclosed in the drawings for describing embodiments of the present disclosure are merely an example, and thus, the present disclosure is not limited to the illustrated details. Like reference numerals refer to like elements throughout. In the following description, when the detailed description of the relevant known function or configuration is determined to unnecessarily obscure the important point of the present disclosure, the detailed description will be omitted. In a case where 'comprise', 'have', and 'include' described in the present specification are used, another part may be added unless 'only~' is used. The terms of a singular form may include plural forms unless referred to the contrary.

[0044] In construing an element, the element is construed as including an error range although there is no explicit description.

[0045] In describing a position relationship, for example, when a position relation between two parts is described as 'on-', 'over-', 'under-', and 'next-', one or more other parts may be disposed between the two parts un-

less 'just' or 'direct' is used.

**[0046]** In describing a time relationship, for example, when the temporal order is described as 'after-', 'subsequent-', 'next-', and 'before-', a case which is not continuous may be included unless 'just' or 'direct' is used.

**[0047]** The term "at least one" should be understood as including any and all combinations of one or more of the associated listed items. For example, the meaning of "at least one of a first item, a second item, and a third item" denotes the combination of all items proposed from two or more of the first item, the second item, and the third item as well as the first item, the second item, or the third item.

**[0048]** It will be understood that, although the terms "first", "second", etc. may be used herein to describe various elements, these elements should not be limited by these terms. These terms are only used to distinguish one element from another. For example, a first element could be termed a second element, and, similarly, a second element could be termed a first element, without departing from the scope of the present disclosure.

**[0049]** Features of various embodiments of the present disclosure may be partially or overall coupled to or combined with each other, and may be variously inter-operated with each other and driven technically as those skilled in the art can sufficiently understand. The embodiments of the present disclosure may be carried out independently from each other, or may be carried out together in co-dependent relationship.

**[0050]** Hereinafter, embodiments of the present disclosure will be described in detail with reference to the accompanying drawings.

**[0051]** FIG. 1 is an exemplary diagram illustrating a configuration of a light emitting display apparatus according to the present disclosure. FIG. 2 is an exemplary diagram illustrating a configuration of one pixel of a light emitting display apparatus according to the present disclosure. FIG. 3 is an exemplary diagram illustrating a configuration of a controller applied to a light emitting display apparatus according to the present disclosure. Particularly, FIG. 2 is an exemplary diagram illustrating a configuration of an  $n^{\text{th}}$  pixel P. In the following description, the  $n^{\text{th}}$  pixel P illustrated in FIG. 2 may be simply referred to as a pixel 110, except a specially desired case.

**[0052]** The light emitting display apparatus according to the present disclosure, as illustrated in FIGS. 1 to 3, may include a light emitting display panel 100 including a pixel 110 which includes a light emitting device ED, e.g. an organic light emitting diode OLED, and a driving transistor Tdr for driving the light emitting device ED, e.g. by controlling a current Ioled flowing through the light emitting device, a controller 400 which, in one frame period, sets black image data corresponding to a black image displayed after a normal image is displayed on an  $n^{\text{th}}$  pixel P, based on a characteristic value of the light emitting display panel 100, a storage unit 450 which stores the characteristic value, a data driver 300 which converts pieces of black image data, transferred from the control-

ler 400, into black image data voltages and outputs the black image data voltages to a plurality of data lines DL1 to DLd included in the light emitting display panel 100, and a gate driver 200 which outputs gate signals to a plurality of gate lines GL1 to GLg included in the light emitting display panel 100, based on control by the controller 400.

**[0053]** Terms used herein will be simply described below. A blank period may denote a period between one frame and another frame. A frame may denote one image. Therefore, the blank period may denote a period between periods where two different images are displayed.

**[0054]** One frame period may denote a period where one image is displayed and may include one blank period between one frame and one other frame. Herein, when the order of one-frame periods is needed, the terms "a first frame period" and "a second frame period" may be used, and when the order of one-frame periods is not needed, the term "one frame period" may be used.

**[0055]** A mode which displays a normal image and then displays a black image during one frame period may be referred to as a black image mode. The black image mode may be used to solve a problem where an image is not clearly seen due to the delay of a motion picture response time (MPRT). In the black image mode, for example, only a normal image desired by a user may be displayed during a fore 1/2 period of one frame period, and during the other 1/2 period, the black image and the normal image may all be displayed.

**[0056]** The normal image may denote an image which is provided in order for a user to watch the image, and particularly, may denote an image which is displayed based on light emitted from one pixel 110. The black image may denote an image which is arbitrarily generated by the controller 400 so as to solve a problem caused by the delay of the MPRT, and particularly, may denote an image which is displayed based on black light emitted from the one pixel 110.

**[0057]** Therefore, normal images displayed on all of a plurality of pixels 110 may configure one image.

**[0058]** That is, as described above, in order to solve the problem caused by the delay of the MPRT, the black image may be arbitrarily generated by the controller 400, and the normal image may be displayed by the pixel 110 on the basis of input video data transferred from an external system.

**[0059]** A data voltage Vdata, used to display the normal image, of data voltages Vdata supplied through the data lines DL may be referred to as a normal image data voltage, and a data voltage Vdata used to display the black image may be referred to as a black image data voltage.

**[0060]** The normal image data voltage may be generated by the data driver 300 on the basis of normal image data, and the black image data voltage may be generated by the data driver 300 on the basis of black image data.

**[0061]** The normal image data may be generated based on the input video data and a normal correction

value, and the black image data may be generated based on reference black image data and a black correction value. A generic name for the normal image data and the black image data may be image data.

**[0062]** The reference black image data may denote a value which is fundamentally applied to all pixels included in the light emitting display panel, for generating the black image data.

**[0063]** The normal correction value may be generated from a variation amount of a threshold voltage and a variation amount of mobility, and the black correction value may be generated from the variation amount of the threshold voltage (hereinafter simply referred to as a threshold voltage variation amount) or a voltage, having minimum value, of normal image data voltages which are output in one frame period.

**[0064]** The threshold voltage variation amount may be calculated when an electronic device is turned on or off, and the variation amount of mobility (hereinafter simply referred to as a mobility variation amount) may be calculated in the blank period.

**[0065]** Hereinafter, the elements will be described sequentially.

**[0066]** First, as illustrated in FIG. 2, the light emitting display panel 100 may include the plurality of pixels 110 which each include the light emitting device ED and the pixel driving circuit PDC. Also, a plurality of pixel areas where the plurality of pixels 110 are respectively provided may be defined in the light emitting display panel 100, and signal lines through which driving signals are supplied to the pixel driving circuit PDC may be provided in the light emitting display panel 100.

**[0067]** The light emitting device ED may include a first electrode, a light emitting layer, and a second electrode provided on the light emitting layer. The light emitting layer may include one of a blue light emitting part, a green light emitting part, and a red light emitting part, for emitting light of a color corresponding to a color which is set in the pixel 110. The light emitting layer may include one of an organic light emitting layer, an inorganic light emitting layer, and a quantum dot light emitting layer, or may include a stacked or combination structure of the organic light emitting layer (or the inorganic light emitting layer) and the quantum dot light emitting layer.

**[0068]** The signal lines may include a gate line GL, a sensing pulse line SPL, a data line DL, a reference voltage line SL, a first driving power line PLA, and a second driving power line PLB.

**[0069]** A plurality of gate lines GL may be arranged in parallel at certain intervals in a first direction (for example, a widthwise direction) of the light emitting display panel 100.

**[0070]** A plurality of sensing pulse lines SPL may be arranged at certain intervals in parallel with the gate lines GL. A sensing pulse SP may be supplied to the sensing pulse lines SPL.

**[0071]** A plurality of data lines DL may be arranged at certain intervals in parallel in a second direction (for ex-

ample, a lengthwise direction) of the light emitting display panel 100 to intersect the gate lines GL and the sensing pulse lines SPL. However, an arrangement structure of the data line DL and the gate line GL may be variously modified.

**[0072]** A plurality of reference voltage lines SL may be arranged at certain intervals in parallel with the data lines DL. However, the present disclosure is not limited thereto. For example, at least three pixels 110 may configure one unit pixel, and in this case, one reference voltage line SL may be provided in the one unit pixel.

**[0073]** To provide an additional description, the data lines DL may be provided in the second direction (for example, the lengthwise direction of FIG. 1) of the light emitting display panel 100, and the reference voltage lines SL may be provided in parallel with the data lines DL and may be respectively connected to at least three pixels 110 configuring each of unit pixels provided in one horizontal line.

**[0074]** A reference voltage Vref may be supplied to the reference voltage line SL.

**[0075]** The reference voltage Vref may be used even when the mobility or threshold voltage of the driving transistor Tdr is sensed, and in a period where images are displayed, the reference voltage Vref may be supplied to a source of the driving transistor Tdr.

**[0076]** The first driving power line PLA may be provided apart from the data line DL and the sensing line SL by a certain interval in parallel therewith. The first driving power line PLA may be connected to a power supply and may transfer a first driving power EVDD, supplied from the power supply, to each pixel 110.

**[0077]** The second driving power line PLB may be provided in plurality, and each of the second driving power lines PLB may transfer a second driving power EVSS, supplied from the power supply, to a corresponding pixel 110.

**[0078]** The pixel driving circuit PDC may include a driving transistor Tdr which controls a level of a current flowing in the light emitting diode ED, a switching transistor Tsw1 which is connected between the data line DL, the driving transistor Tdr, and the gate line GL, and a sensing transistor Tsw2 for transferring the reference voltage Vref to a source of the driving transistor Tdr, and a capacitor Cst connected between a first node n1 and a second node n2. Also, the pixel driving circuit PDC included in each of the pixels 110 may further include transistors for external compensation.

**[0079]** That is, a structure of the pixel driving circuit PDC may be changed to various structures for performing the external compensation, and a method of driving the pixel driving circuit PDC may also be changed variously.

**[0080]** The external compensation may denote an operation of calculating a variation amount of a threshold voltage or mobility of the driving transistor Tdr provided in the pixel 110 and varying a level of a data voltage supplied to the pixel 110 on the basis of the variation

amount. Therefore, in order to calculate the variation amount of the threshold voltage or mobility of the driving transistor Tdr, a structure of the pixel 110 may be changed to various structures.

**[0081]** Moreover, in order to perform the external compensation, a method of calculating the variation amount of the threshold voltage or mobility of the driving transistor Tdr by using the pixel 110 may be variously changed based on the structure of the pixel 110.

**[0082]** In this case, sensing for the external compensation may be performed on one gate line in one (vertical) blank period and may be performed when an electronic device (for example, a television (TV), a monitor, a smartphone, a table personal computer (PC), or the like) including the light emitting display apparatus is turned on or off.

**[0083]** In the blank period, for example, the variation amount of mobility of the driving transistor Tdr may be sensed, and when the electrode device is turned on or off, the variation amounts of threshold voltages of the driving transistors Tdr may be sensed.

**[0084]** When the electronic device is again turned on, the controller 400 may generate correction values for correcting the variation amounts of threshold voltages of the driving transistors Tdr and may correct pieces of input video data transferred from the external system by using the correction values to generate pieces of normal image data. The pieces of normal image data may be transferred to the data driver 300.

**[0085]** In the blank period, while the variation amount of mobility is being sensed, the reference voltage Vref or another voltage for the sensing may be supplied to the reference voltage line SL.

**[0086]** When the sensing is not performed, the reference voltage Vref may be supplied to the reference voltage line SL and may maintain a voltage at the source of the driving transistor Tdr. Therefore, the reference voltage Vref has to be maintained to have a value within a certain range.

**[0087]** That is, the present disclosure relates to a light emitting display apparatus which uses threshold voltages calculated through the external compensation and does not directly relate to an external compensation method.

**[0088]** Therefore, a structure of each pixel for the external compensation may be implemented as various pixel structures proposed for the external compensation, and a method of performing the external compensation may be implemented as various external compensation methods.

**[0089]** That is, a detailed structure of each pixel for performing the external compensation and a detailed method for the external compensation are irrelevant to the scope of the present disclosure. Therefore, an example of a pixel for the external compensation has been simply described above with reference to FIG. 2, and an external compensation method will be simply described below.

**[0090]** Moreover, the present disclosure may be ap-

plied to a light emitting display apparatus including the reference voltage line SL and the sensing transistor Tsw2, for internal compensation. A structure of the pixel 110 including the reference voltage line SL may be changed to various structures, for the internal compensation, and an internal compensation method may be variously changed based on a structure of the pixel 110.

**[0091]** Moreover, as described above, the present disclosure may use the black image mode. The structure of the pixel 110 with the black image mode applied thereto may be variously changed based on the black image mode, in addition to the structure illustrated in FIG. 2.

**[0092]** That is, FIG. 2 illustrates the structure of the pixel 110 for performing the external compensation and the black image mode, and thus, the structure of the pixel 110 may be changed to various structures, in addition to the structure illustrated in FIG. 2.

**[0093]** Hereinafter, a light emitting display apparatus including the pixels 110 illustrated in FIG. 2 will be described as an example of the present disclosure.

**[0094]** Second, the gate driver 200 may sequentially supply a gate-on signal GP to a plurality of gate lines GL1 to GLg included in the light emitting display panel 100 by using gate control signals GCS transferred from the controller 400. The gate control signals GCS may include n (where n is an integer equal to or more than two) number of gate clocks GCLK.

**[0095]** Here, the gate-on signal GP may denote a signal for turning on the switching transistor Tsw1 connected to a corresponding gate line of the gate lines GL1 to GLg. A signal for turning off the switching transistor Tsw1 may be referred to as a gate-off signal. A generic name for the gate-on signal GP and the gate-off signal may be a gate signal.

**[0096]** The gate driver 200 may be provided independently from the light emitting display panel 100 and may be connected to the light emitting display panel 100 through a tape carrier package (TCP), a chip-on film (COF), or a flexible printed circuit board (FPCB), but is not limited thereto. In other embodiments, the gate driver 200 may be directly provided outside the light emitting display panel 100 by using a gate-in panel (GIP) type, based on a process of manufacturing the pixel driving circuit PDC.

**[0097]** Third, the power supply may supply power to the gate driver 200, the data driver 300, and the controller 400.

**[0098]** Fourth, the data driver 300 may convert pieces of normal image data Data, transferred from the controller 400, into normal data voltages Vdata and may supply the normal data voltages to the data lines DL1 to DLd.

**[0099]** Fifth, the controller 400 may control the gate driver 200 and the data driver 300.

**[0100]** The controller 400, as illustrated in FIG. 3, may generate a gate control signal GCS for controlling driving of the gate driver 200 and a data control signal DCS for controlling driving of the data driver 300 by using a timing synchronization signal TSS input from the external sys-

tem.

**[0101]** Moreover, in a sensing mode where sensing for the external compensation is performed, the controller 400 may transfer pieces of sensing image data, which are to be supplied to pixels connected to a gate line on which the external compensation is performed, to the data driver 300.

**[0102]** Sensing for the external compensation may be performed at various timings. For example, the variation amounts of mobility of the driving transistors Tdr may be sensed in the blank period, and when the electronic device is turned on or off, the variation amounts of mobility of the driving transistors Tdr may be sensed.

**[0103]** The controller 400 may calculate normal correction values on the basis of pieces of sensing data Sdata which are provided from the data driver through the above-described sensing process and may store the normal correction values in the storage unit 450.

**[0104]** In a display period where an image is displayed, the controller 400 may correct pieces of input video data Ri, Gi, and Bi transferred from the external system by using the normal correction values to generate pieces of normal image data. The data driver 300 may convert the pieces of normal image data into normal image data voltages and may supply the normal image data voltages to the data lines DL1 to DLd.

**[0105]** Particularly, at a timing at which the black image is output, the controller 400 may generate pieces of black image data which are to be output to pixels, based on a voltage, having a minimum value, of normal image data voltages which are to be output in one frame period or a threshold variation amount determined based on the sensing data Sdata.

**[0106]** In order to perform the above-described function, as illustrated in FIG. 3, the controller 400 may include a data aligner which realigns the pieces of input video data Ri, Gi, and Bi transferred from the external system by using the timing synchronization signal TSS transferred from the external system and supplies pieces of realigned image data to the data driver 300, a control signal generator 420 which generates the gate control signal GCS and the data control signal DCS by using the timing synchronization signal TSS, a calculator 410 which calculates a normal correction value for compensating for a characteristic variation of the driving transistor Tdr provided in each of the pixels 110 by using the pieces of sensing data Sdata transferred from the data driver 300, the storage unit 450 which stores the normal correction value, and an output unit 440 which outputs, to the data driver 300 or the gate driver 200, pieces of normal image data Data generated by the data aligner 430 and the gate control signal GCS and the data control signal DCS each generated by the control signal generator 200.

**[0107]** The storage unit 450 may be included in the controller 400, or may be implemented independently from the controller 400 as illustrated in FIG. 3.

**[0108]** The storage unit 450 may store threshold volt-

ages (hereinafter simply referred to as a start threshold voltage) measured from the driving transistors of all pixels 110 of the light emitting display panel 100 in a process of manufacturing the light emitting display panel 100 and threshold voltages of the pixels 110 measured through sensing which is performed when the electronic device is turned off. In this case, in the sensing which is performed when the electronic device is turned off, the threshold voltages of all the pixels 110 included in the light emitting display panel 100 may be sensed, but only threshold voltages of at least two of the all pixels 110 may be sensed.

**[0109]** When the electronic device is turned on or off, the controller 400 may calculate a threshold voltage variation amount of at least one of all the pixels 110 by using the start threshold voltage and the threshold voltage, and the calculated threshold voltage variation amount may be stored in the storage unit 450.

**[0110]** Particularly, in one frame period, the controller 400 may set black image data corresponding to a black image which is displayed after a normal image is displayed on a pixel, based on a characteristic value of the light emitting display panel.

**[0111]** In this case, the controller 400 may correct reference black image data fundamentally applied to the pixels by using a black correction value calculated based on the characteristic value to generate the black image data.

**[0112]** The black correction value may be generated by the calculator 410, and the data aligner 430 may perform a process of converting the reference black image data by using the black correction value to generate the black image data.

**[0113]** Hereinafter, a driving method of the light emitting display apparatus according to the present disclosure will be described with reference to FIGS. 1 to 6.

**[0114]** FIG. 4 is an exemplary diagram illustrating a driving period of a light emitting display apparatus according to the present disclosure, and FIG. 5 is an exemplary diagram illustrating data voltages applied to a light emitting display apparatus according to the present disclosure. Hereinafter, descriptions which are the same as or similar to descriptions given above with reference to FIGS. 1 to 3 are omitted or will be simply given.

**[0115]** A driving method of the light emitting display apparatus will be described below.

**[0116]** First, as shown in FIG. 4, when a first frame period starts, the controller 400 may convert pieces of input video data, transferred from the external system, into pieces of normal image data by using the normal correction values.

**[0117]** The controller 400 may transfer the pieces of normal image data to the data driver 300.

**[0118]** Subsequently, the data driver 300 may convert the pieces of normal image data into normal image data voltages Vdata\_I and may output the normal image data voltages Vdata\_I to the data lines DL1 to DLd.

**[0119]** Therefore, as shown in FIG. 4, a normal image

I may be sequentially output along the gate lines.

**[0120]** For example, as illustrated in FIG. 2, when a threshold voltage of an N-type driving transistor Tdr included in the pixel driving circuit PDC configuring an n<sup>th</sup> pixel P is shifted in a positive direction, in order for the n<sup>th</sup> pixel P to output an image having luminance which is the same as luminance before the threshold voltage is shifted, as illustrated in FIG. 5, a normal image data voltage Vdata\_I where a threshold voltage variation amount "Vth" is added to a data voltage Vdata corresponding to the input video data may be supplied to the data line.

**[0121]** Subsequently, when a predetermined period elapses after the normal image data voltage Vdata\_I is output through the n<sup>th</sup> pixel P, a black image data voltage Vdata\_BI may be output from the n<sup>th</sup> pixel P.

**[0122]** To this end, the controller 400 may generate black image data corresponding to the black image data voltage Vdata\_BI where the threshold voltage variation amount "Vth" is added to a reference black image data voltage Vdata\_Bref.

**[0123]** To this end, the controller 400 may generate a black correction value by using the threshold voltage variation amount "Vth" of the driving transistor Tdr included in the n<sup>th</sup> pixel P.

**[0124]** The controller 400 may correct the reference black image data by using the black correction value to generate the black image data.

**[0125]** The controller 400 may transfer the black image data to the data driver 300.

**[0126]** That is, in an embodiment illustrated in FIG. 5, in one frame period, the controller 400 may set black image data corresponding to the black image which is output after the normal image is output through the n<sup>th</sup> pixel P, based on the characteristic value of the light emitting display panel, and particularly, a threshold voltage variation amount of a driving transistor included in the n<sup>th</sup> pixel may be used as the characteristic value.

**[0127]** Finally, the data driver 300 may convert the black image data into the black image data voltage Vdata\_BI and may supply the black image data voltage Vdata\_BI to a data line DL connected to the n<sup>th</sup> pixel P.

**[0128]** The black image data voltage Vdata\_BI generated by the data driver 300 on the basis of the black image data corresponding to the n<sup>th</sup> pixel P may be a voltage which increases by the threshold voltage variation amount "Vth" of the pixel in comparison with the reference black image data voltage Vdata\_Bref applied to the all pixels included in the light emitting display panel 100. In this case, the black image data voltage may be a voltage which decreases by the threshold voltage variation amount "Vth" of the pixel in comparison with the reference black image data voltage Vdata\_Bref, based on the kind and current/voltage characteristic of a semiconductor included in the driving transistor.

**[0129]** Hereinafter, a light emitting display apparatus where the black image data voltage increases by the threshold voltage variation amount of the pixel in comparison with the reference black image data voltage will

be described as an example of the present disclosure.

**[0130]** In this case, a difference C between the black image data voltage Vdata\_BI and the normal image data voltage Vdata\_I may be less than a difference D between the reference black image data voltage Vdata\_Bref and the normal image data voltage Vdata\_I.

**[0131]** The reference voltage Vref supplied to the reference voltage line SL may maintain a voltage at the source of the driving transistor Tdr when the normal image data voltage Vdata\_I and the black image data voltage Vdata\_BI are output to the data line DL.

**[0132]** However, the reference voltage line SL may be adjacent to the data line DL, and thus, as illustrated in FIG. 5, the reference voltage Vref supplied through the reference voltage line SL may be coupled to a data voltage supplied through the data line and may be shaken.

**[0133]** In this case, since the difference C between the black image data voltage Vdata\_BI and the normal image data voltage Vdata\_I may be less than the difference D between the reference black image data voltage Vdata\_Bref and the normal image data voltage Vdata\_I, a variation amount Y1 of the reference voltage Vref when the black image data voltage Vdata\_BI is supplied to the data line DL may be less than a variation amount Y2 of the reference voltage Vref when the reference black image data voltage Vdata\_Bref is supplied to the data line DL.

**[0134]** Therefore, when another normal image data voltage Vdata\_I is output to the n<sup>th</sup> pixel P in a second frame period after the black image data voltage Vdata\_BI is output, a reference voltage which is within a predetermined range may be supplied to the source of the driving transistor Tdr.

**[0135]** Therefore, the n<sup>th</sup> pixel P may display an image having brightness predicted based on the other normal image data voltage Vdata\_I.

**[0136]** Therefore, a luminance defect may not occur in the light emitting display panel 100.

**[0137]** In a period where the black image data voltage Vdata\_BI is supplied, black image data voltages Vdata\_BI respectively applied to the pixels 110 of the light emitting display panel 100 may differ.

**[0138]** That is, a voltage which is supplied to each of the pixels 110 in the period where the black image data voltage Vdata\_BI is supplied may be a black image data voltage Vdata\_BI in which the threshold voltage variation amount "Vth" of the pixel 110 is reflected. Therefore, when the threshold voltage variation amounts "Vth" of the pixels 110 differ, black image data voltages Vdata\_BI respectively applied to the pixels 110 may differ. In this case, a precise black image data voltage Vdata\_BI in which a pixel-based feature of the light emitting display panel 100 is reflected may be applied.

**[0139]** However, in the period where the black image data voltage Vdata\_BI is supplied, the black image data voltages Vdata\_BI respectively applied to the pixels 110 of the light emitting display panel 100 may be the same voltages.

**[0140]** For example, the controller 400 may calculate an average threshold voltage variation amount of the threshold voltage variation amounts "Vth" of the pixels 110 and may reflect the calculated average threshold voltage variation amount in the black image data voltage Vdata\_BI. In this case, the black image data voltages Vdata\_BI respectively applied to the pixels 110 may be the same voltages.

**[0141]** In this case, the black image data voltages Vdata\_BI which are to be respectively applied to the pixels 110 may not be calculated. Therefore, even when the black image data voltage Vdata\_BI is supplied, the light emitting display apparatus according to the present disclosure may be quickly driven.

**[0142]** Here, the average threshold voltage variation amount may be an average of threshold voltage variation amounts of all pixels 110 included in the light emitting display panel 100, or may be an average of threshold voltage variation amounts of at least two of all the pixels 110. For example, in a case where the threshold voltage variation amount is calculated from only some of the all pixels 110 included in the light emitting display panel 100, the average threshold voltage variation amount may be an average of the calculated threshold voltage variation amounts.

**[0143]** FIG. 6 is another exemplary diagram illustrating data voltages applied to a light emitting display apparatus according to the present disclosure.

**[0144]** Hereinafter, descriptions which are the same as or similar to descriptions given above with reference to FIGS. 1 to 5 are omitted or will be simply given.

**[0145]** A driving method of the light emitting display apparatus will be described below.

**[0146]** First, as shown in FIG. 4, when a first frame period starts, the controller 400 may convert pieces of input video data, transferred from the external system, into pieces of normal image data by using the normal correction values.

**[0147]** The controller 400 may transfer the pieces of normal image data to the data driver 300.

**[0148]** Subsequently, the data driver 300 may convert the pieces of normal image data into normal image data voltages Vdata\_I and may output the normal image data voltages Vdata\_I to the data lines DL1 to DLd.

**[0149]** Therefore, as shown in FIG. 4, a normal image I may be sequentially output along the gate lines.

**[0150]** For example, as illustrated in FIG. 2, when a threshold voltage of an N-type driving transistor Tdr included in the pixel driving circuit PDC configuring an n<sup>th</sup> pixel P is shifted in a positive direction, in order for the n<sup>th</sup> pixel P to output an image having luminance which is the same as luminance before the threshold voltage is shifted, as illustrated in FIG. 5, a normal image data voltage Vdata\_I where a threshold voltage variation amount "Vth" is added to a data voltage Vdata corresponding to the input video data may be supplied to the data line. In FIG. 5, the threshold voltage variation amount "Vth" is shown in a graph showing the data voltage Vdata, but in

FIG. 6, a normal image data voltage Vdata\_I to which a threshold voltage variation amount "Vth" is added is shown as the data voltage Vdata.

**[0151]** Subsequently, when a predetermined period elapses after the normal image data voltage Vdata\_I is output through the n<sup>th</sup> pixel P, a black image data voltage Vdata\_BI may be output from the n<sup>th</sup> pixel P.

**[0152]** To this end, the controller 400 may generate black image data corresponding to a black image data voltage Vdata\_BI which is set based on a voltage, having a minimum value, of normal image data voltages which are output from all the pixels of the light emitting display panel in one frame period where the black image data is output.

**[0153]** To this end, the controller 400 may generate the black correction value by using the voltage, having the minimum value, of normal image data voltages which are output from all the pixels of the light emitting display panel in one frame period where the black image data is output. That is, a characteristic value of the light emitting display panel 100 which is used for the controller 400 to generate the black correction value may be the minimum value.

**[0154]** The controller 400 may correct the reference black image data by using the black correction value to generate the black image data.

**[0155]** The controller 400 may transfer the black image data to the data driver 300.

**[0156]** Finally, the data driver 300 may convert the black image data into the black image data voltage Vdata\_BI and may supply the black image data voltage Vdata\_BI to a data line DL connected to the n<sup>th</sup> pixel P.

**[0157]** In this case, the black image data voltage Vdata\_BI generated by the data driver 300 on the basis of black image data corresponding to the n<sup>th</sup> pixel P may be greater than the reference black image data voltage Vdata\_Bref applied to all of the pixels 110 included in the light emitting display panel 100 and may be less than the minimum value. In other words, the controller 400 may select one as the black image data voltage Vdata\_BI among the values which are greater than the reference black image data voltage Vdata\_Bref and less than the minimum value. For example, an average value of the reference black image data voltage Vdata\_Bref and the minimum value may be selected as the black image data voltage Vdata\_BI. However, the black image data voltage Vdata\_BI may be variously set by setup information stored in the storage unit 450 by the manufacturer of the light emitting display device according to the present invention, in addition to the average value.

**[0158]** Moreover, the black image data voltage Vdata\_BI generated by the data driver 300 on the basis of black image data corresponding to the n<sup>th</sup> pixel P may be greater than the reference black image data voltage Vdata\_Bref and may be less than a predetermined highest black image data voltage Vdata\_H, and when the minimum value is greater than the highest black image data voltage Vdata\_H, the black image data voltage

Vdata\_BI may be the highest black image data voltage Vdata\_H.

**[0159]** For example, when the highest black image data voltage Vdata\_H has a highest value among data voltages capable of expressing black, that a voltage having a minimum value among normal image data voltages Vdata\_I output in one frame period is greater than the highest black image data voltage Vdata\_H may denote that an image displayed based on the minimum value does not express black.

**[0160]** Therefore, when the minimum value is greater than a value of the highest black image data voltage Vdata\_H, the black image data voltage Vdata\_BI may be the highest black image data voltage Vdata\_H.

**[0161]** In this case, a difference E between the black image data voltage Vdata\_BI and the normal image data voltage Vdata\_I may be less than a difference F between the reference black image data voltage Vdata\_Bref and the normal image data voltage Vdata\_I.

**[0162]** The reference voltage Vref supplied to the reference voltage line SL may maintain a voltage at the source of the driving transistor Tdr when the normal image data voltage Vdata\_I and the black image data voltage Vdata\_BI are output to the data line DL.

**[0163]** However, the reference voltage line SL may be adjacent to the data line DL, and thus, as illustrated in FIG. 5, the reference voltage Vref supplied through the reference voltage line SL may be coupled to a data voltage supplied through the data line and may be shaken.

**[0164]** In this case, since the difference E between the black image data voltage Vdata\_BI and the normal image data voltage Vdata\_I may be less than the difference F between the reference black image data voltage Vdata\_Bref and the normal image data voltage Vdata\_I, a variation amount Y3 of the reference voltage Vref when the black image data voltage Vdata\_BI is supplied to the data line DL may be less than a variation amount Y4 of the reference voltage Vref when the reference black image data voltage Vdata\_Bref is supplied to the data line DL.

**[0165]** Therefore, when another normal image data voltage Vdata\_I is output to the n<sup>th</sup> pixel P in a second frame period after the black image data voltage Vdata\_BI is output, a reference voltage which is within a predetermined range may be supplied to the source of the driving transistor Tdr.

**[0166]** Therefore, the n<sup>th</sup> pixel P may display an image having brightness predicted based on the other normal image data voltage Vdata\_I.

**[0167]** Therefore, a luminance defect may not occur in the light emitting display panel 100.

**[0168]** In the present disclosure, a difference between the normal image data voltage Vdata\_I and the black image data voltage Vdata\_BI may decrease, and thus, shaking of the reference voltage Vref coupled to the normal image data voltage Vdata\_I and the black image data voltage Vdata\_BI may be reduced.

**[0169]** Since shaking of the reference voltage Vref is

reduced, the reference voltage Vref which is within a certain range may be supplied to the source of the driving transistor Tdr to which the reference voltage Vref is supplied, and thus, a difference voltage between the source and a gate of the driving transistor Tdr may stably vary based on the normal image data voltage Vdata\_I.

**[0170]** Therefore, a current passing through the driving transistor Tdr may vary based on the normal image data voltage Vdata\_I, and thus, an image having brightness corresponding to the normal image data voltage Vdata\_I may be displayed by using the light emitting device ED.

**[0171]** As described above, according to the present disclosure, black image data for displaying a black image may be set for each pixel on the basis of the characteristic of the light emitting display panel.

**[0172]** That is, according to the present disclosure, a black image data voltage for displaying the black image may be set based on a variation amount of a threshold voltage of a driving transistor included in a pixel, and thus, a difference between a normal image data voltage for displaying a normal image and the black image data voltage for displaying the black image may be reduced.

**[0173]** Moreover, according to the present disclosure, the black image data voltage for displaying the black image may be set to a voltage, which is close to a minimum value, of normal image data voltages for displaying the normal image, and thus, a difference between the normal image data voltage for displaying the normal image and the black image data voltage for displaying the black image may be reduced.

**[0174]** Therefore, a distortion amount of a reference voltage supplied to a reference voltage line provided in parallel with a data line due to a coupling between the data line and the reference voltage line may decrease due to a reduced difference between normal image data voltages and black image data voltages supplied to the data line, and thus, image quality may be enhanced.

**[0175]** The above-described feature, structure, and effect of the present disclosure are included in at least one embodiment of the present disclosure, but are not limited to only one embodiment. Furthermore, the feature, structure, and effect described in at least one embodiment of the present disclosure may be implemented through combination or modification of other embodiments by those skilled in the art. Therefore, content associated with the combination and modification should be construed as being within the scope of the present disclosure.

**[0176]** It will be apparent to those skilled in the art that various modifications and variations can be made in the present disclosure without departing from the scope of the disclosure. Thus, it is intended that the present disclosure covers the modifications and variations of this disclosure provided they come within the scope of the appended claims.

## Claims

1. A light emitting display apparatus comprising:
  - a light emitting display panel (100) including a plurality of pixels (110, P) respectively including a light emitting device (OLED) and a driving transistor (Tdr) configured to drive the light emitting device (OLED);
  - a controller (400) configured to set black image data corresponding to a black image displayed through an n<sup>th</sup> pixel (110, P) after a normal image is displayed through the n<sup>th</sup> pixel (110, P) in one frame period, based on a characteristic value of the light emitting display panel (100);
  - a storage unit (450) configured to store the characteristic value generated from the light emitting display panel (100);
  - a data driver (300) configured to convert pieces of black image data, transferred from the controller (400), into black image data voltages (Vdata\_BI) and to output the black image data voltages (Vdata\_BI) to data lines (DL1, ..., DLd) included in the light emitting display panel (100); and
  - a gate driver (200) configured to output gate signals to gate lines (GL1, ..., GLg) included in the light emitting display panel (100), based on control by the controller (400).
2. The light emitting display apparatus of claim 1, wherein
  - the characteristic value is or includes a threshold voltage variation amount (Vth) of a driving transistor (Tdr) included in at least one of the pixels (110, P) included in the light emitting display panel (100), and the controller (400) is configured to generate the black image data corresponding to the n<sup>th</sup> pixel (110, P) by using the threshold voltage variation amount (Vth).
3. The light emitting display apparatus of claim 2, wherein the threshold voltage variation amount (Vth) applied to the n<sup>th</sup> pixel (110, P) is a threshold voltage variation amount (Vth) of a driving transistor (Tdr) included in the n<sup>th</sup> pixel (110, P).
4. The light emitting display apparatus of claim 2 or 3, wherein the threshold voltage variation amount (Vth) is generated after an apparatus turn-off signal is received from an external system, and is stored in the storage unit (450).
5. The light emitting display apparatus of any one of claims 2 to 4, wherein
  - the storage unit (450) is configured to store a start threshold voltage measured from the at least one pixel (110, P) in a process of manufacturing the light emitting display panel (110, P) and a threshold voltage which is measured from the at least one pixel (110, P) after an apparatus turn-off signal is received, and
  - the controller (400) is configured to calculate the threshold voltage variation amount (Vth) by using the start threshold voltage and the threshold voltage.
6. The light emitting display apparatus of any one of claims 2 to 5, wherein a black image data voltage (Vdata\_BI) generated by the data driver (300) on the basis of black image data corresponding to the n<sup>th</sup> pixel (110, P) is a voltage which varies by the threshold voltage variation amount (Vth) of the at least one pixel (110, P) in comparison with a reference black image data voltage (Vdata\_Bref) applied to all the pixels (110, P) included in the light emitting display panel (100).
7. The light emitting display apparatus of any one of claims 2 to 6, wherein the threshold voltage variation amount (Vth) applied to the n<sup>th</sup> pixel (110, P) is an average of threshold voltage variation amounts (Vth) of at least two of all driving transistors (Tdr) included in the light emitting display panel (100).
8. The light emitting display apparatus of claim 7, wherein the controller (400) is configured to generate the pieces of black image data corresponding to all the pixels (110, P) included in the light emitting display panel (100), based on the average.
9. The light emitting display apparatus of claim 8, wherein the pieces of black image data corresponding to all the pixels (110, P) included in the light emitting display panel (100), based on the average, are equal.
10. The light emitting display apparatus of any one of claims 1 to 9, wherein pieces of black image data corresponding to all the pixels (110, P) included in the light emitting display panel (100) are not equal.
11. The light emitting display apparatus of any one of claims 1 to 10, wherein
  - the characteristic value is or includes a minimum value among values of pieces of normal image data voltages (Vdata\_I) which are output to all pixels (110, P) included in the light emitting display panel (100) in one frame period, and
  - the controller (400) is configured to generate the black image data by using the minimum value.
12. The light emitting display apparatus of claim 11, wherein a black image data voltage (Vdata\_BI) generated by the data driver (300) on the basis of black image data corresponding to the n<sup>th</sup> pixel (110, P) is

greater than a reference black image data voltage (Vdata\_Bref) applied to all the pixels (110, P) included in the light emitting display panel (100) and is less than the minimum value.

5

- 13.** The light emitting display apparatus of claim 11 or 12, wherein a black image data voltage (Vdata\_BI) generated by the data driver (300) on the basis of black image data corresponding to the  $n^{\text{th}}$  pixel (110, P) is greater than a reference black image data voltage (Vdata\_Bref) and is less than a predetermined highest black image data voltage (Vdata\_H).

10

- 14.** The light emitting display apparatus of claim 13, wherein, when the minimum value is greater than the highest black image data voltage (Vdata\_H), the black image data voltage (Vdata\_BI) is the highest black image data voltage (Vdata\_H).

15

20

25

30

35

40

45

50

55

FIG. 1

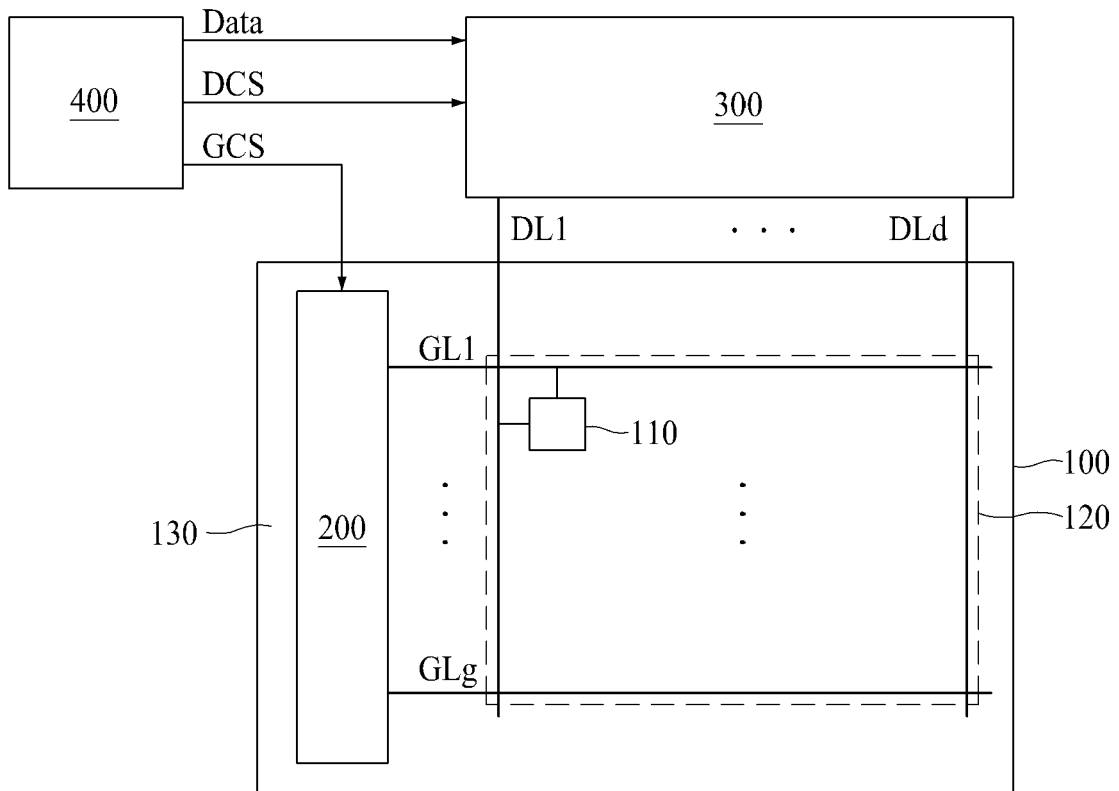

FIG. 2

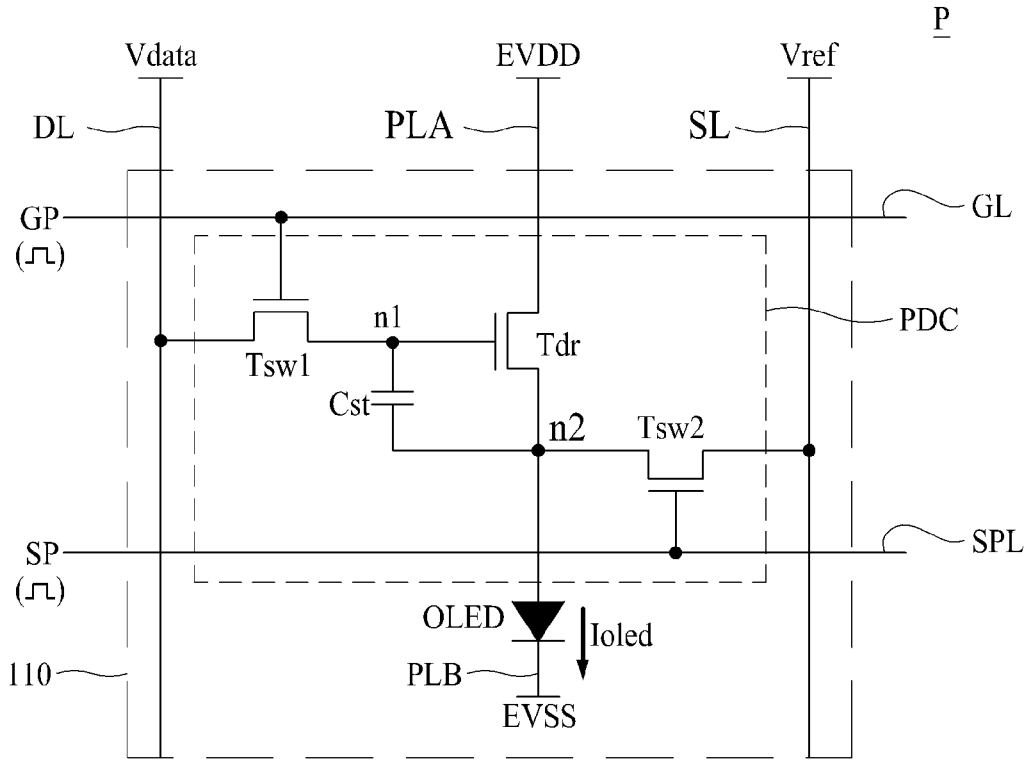

FIG. 3

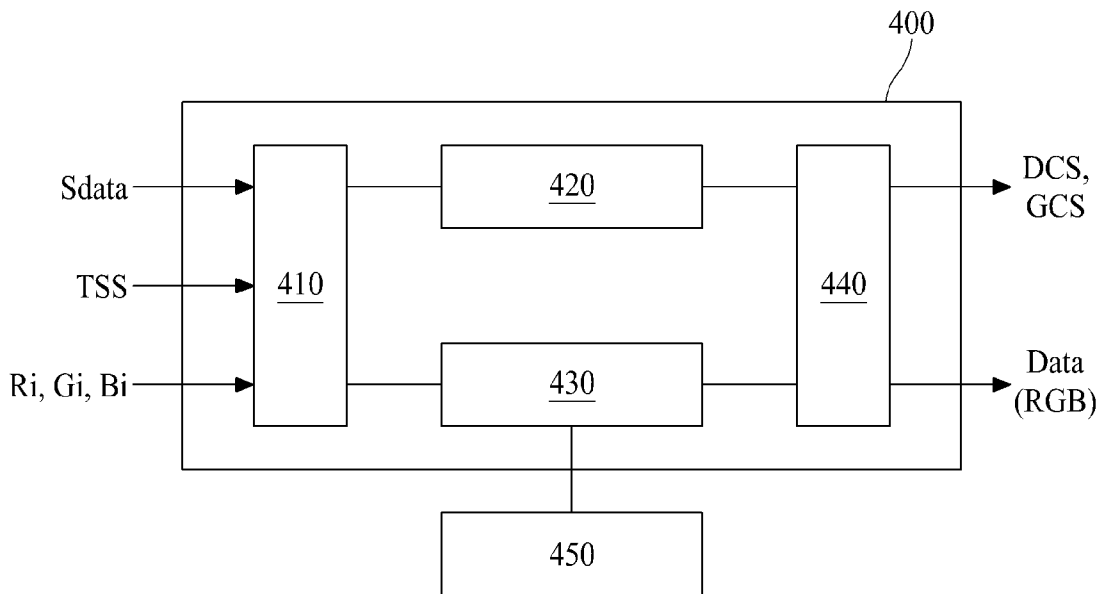

FIG. 4

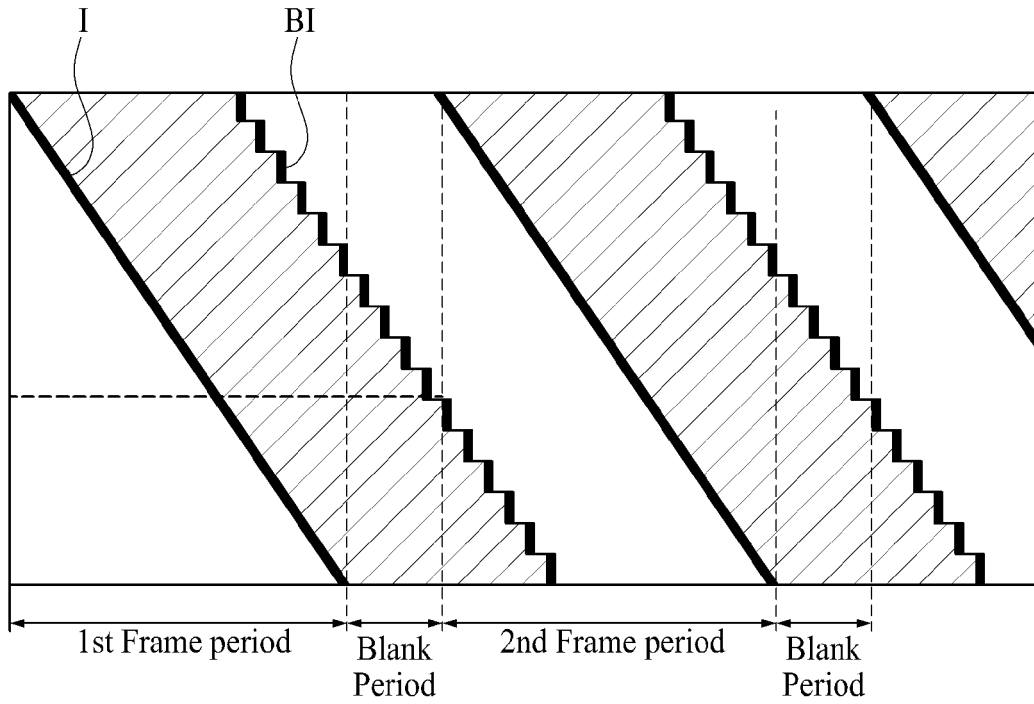

FIG. 5

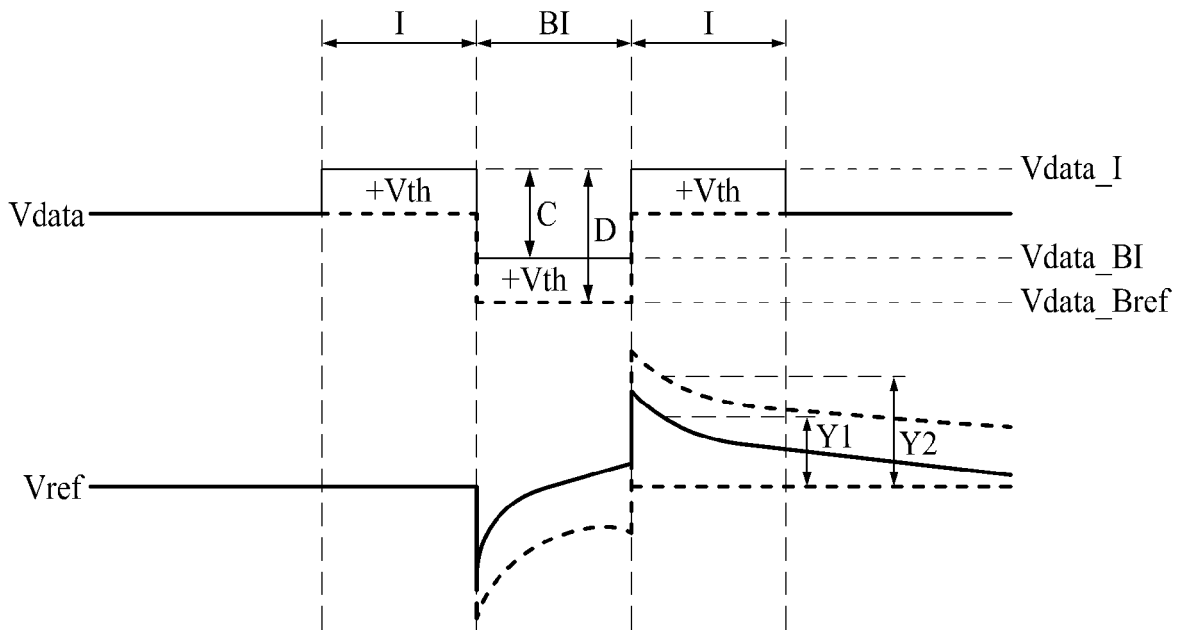
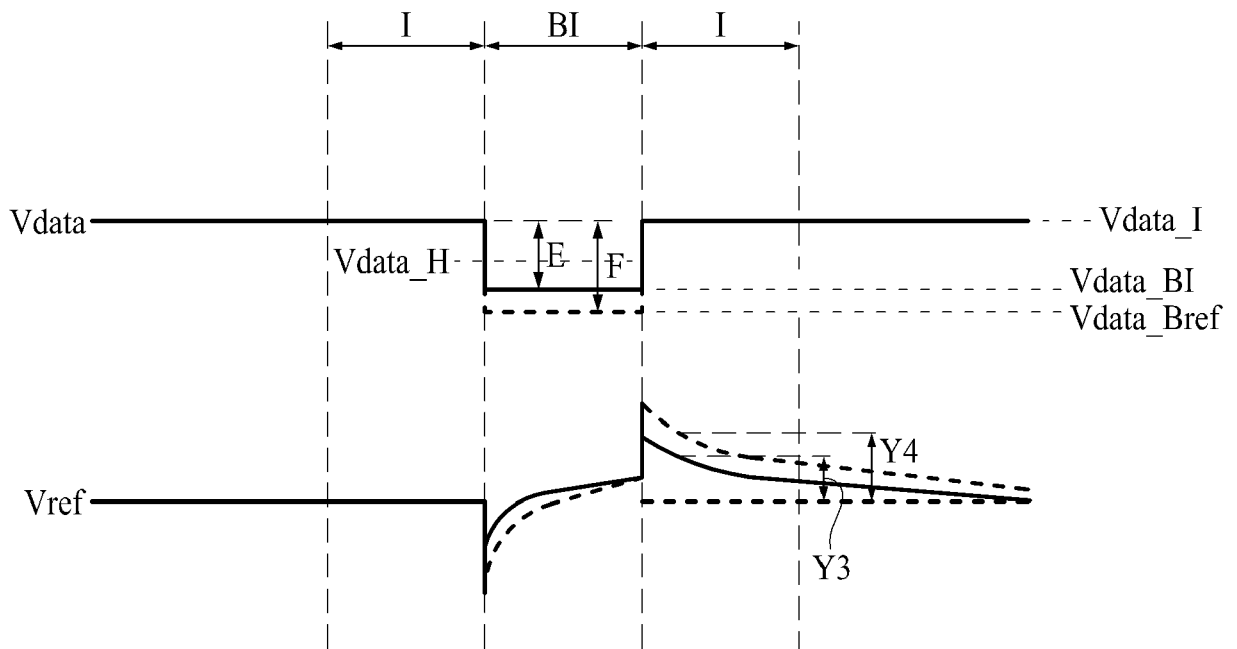

FIG. 6





EUROPEAN SEARCH REPORT

Application Number  
EP 19 21 8631

5

10

15

20

25

30

35

40

45

50

55

DOCUMENTS CONSIDERED TO BE RELEVANT			
Category	Citation of document with indication, where appropriate, of relevant passages	Relevant to claim	CLASSIFICATION OF THE APPLICATION (IPC)
X	US 2010/091006 A1 (YOO MYOUNG-HWAN [KR] ET AL) 15 April 2010 (2010-04-15) * paragraphs [0003], [0031], [0032], [0034], [0043], [0045], [0058]; figures 1,2,3 *	1-3,6-14	INV. G09G3/3233
X	----- KR 2016 0055324 A (LG DISPLAY CO LTD [KR]) 18 May 2016 (2016-05-18) * figures 1,2,3 *	1-14	
X	----- US 2007/080906 A1 (TANABE TAKAHISA [JP]) 12 April 2007 (2007-04-12) * paragraphs [0031] - [0033]; figures 3,4,6 *	1	
The present search report has been drawn up for all claims			TECHNICAL FIELDS SEARCHED (IPC)
			G09G
Place of search		Date of completion of the search	Examiner
The Hague		2 April 2020	Ladiray, Olivier
CATEGORY OF CITED DOCUMENTS			
X : particularly relevant if taken alone Y : particularly relevant if combined with another document of the same category A : technological background O : non-written disclosure P : intermediate document		T : theory or principle underlying the invention E : earlier patent document, but published on, or after the filing date D : document cited in the application L : document cited for other reasons ..... & : member of the same patent family, corresponding document	

EPO FORM 1503 03/02 (P04C01)

**ANNEX TO THE EUROPEAN SEARCH REPORT  
ON EUROPEAN PATENT APPLICATION NO.**

EP 19 21 8631

5 This annex lists the patent family members relating to the patent documents cited in the above-mentioned European search report.  
The members are as contained in the European Patent Office EDP file on  
The European Patent Office is in no way liable for these particulars which are merely given for the purpose of information.

02-04-2020

Patent document cited in search report	Publication date	Patent family member(s)	Publication date
US 2010091006 A1	15-04-2010	KR 20100041085 A US 2010091006 A1	22-04-2010 15-04-2010
-----			
KR 20160055324 A	18-05-2016	NONE	
-----			
US 2007080906 A1	12-04-2007	CN 1864190 A JP 4068640 B2 JP W02005034072 A1 KR 20060064683 A TW 1254898 B US 2007080906 A1 WO 2005034072 A1	15-11-2006 26-03-2008 14-12-2006 13-06-2006 11-05-2006 12-04-2007 14-04-2005
-----			

EPO FORM P0459

For more details about this annex : see Official Journal of the European Patent Office, No. 12/82

专利名称(译)	电致发光显示器		
公开(公告)号	<a href="#">EP3675109A1</a>	公开(公告)日	2020-07-01
申请号	EP2019218631	申请日	2019-12-20
[标]申请(专利权)人(译)	乐金显示有限公司		
申请(专利权)人(译)	LG DISPLAY CO. , LTD.		
当前申请(专利权)人(译)	LG DISPLAY CO. , LTD.		
[标]发明人	SHIM JOOSUNG HONG MOOKYOUNG		
发明人	SHIM, JOOSUNG HONG, MOOKYOUNG		
IPC分类号	G09G3/3233		
CPC分类号	G09G3/3233 G09G2320/0219 G09G2320/0261 G09G2320/0295 G09G2320/043 G09G3/3225 H01L27/3246 H01L27/326 H01L51/50		
审查员(译)	LADIRAY , OLIVIER		
优先权	1020180172030 2018-12-28 KR		
外部链接	<a href="#">Espacenet</a>		

摘要(译)

公开了一种发光显示装置,其基于发光显示器的特性,针对一帧周期中的每个像素设置与显示正常图像(I)之后显示的黑色图像(BI)相对应的黑色图像数据。 面板。

FIG. 4

