

(19)



(11)

EP 2 232 557 B1

(12)

EUROPEAN PATENT SPECIFICATION

(45) Date of publication and mention of the grant of the patent:

03.05.2017 Bulletin 2017/18

(51) Int Cl.:

H01L 27/32^(2006.01) G09G 3/32^(2016.01)

(21) Application number: **08859715.8**

(86) International application number:

PCT/US2008/013254

(22) Date of filing: **01.12.2008**

(87) International publication number:

WO 2009/075740 (18.06.2009 Gazette 2009/25)

(54) **PIXEL CIRCUIT**

PIXELSCHALTUNG

CIRCUIT DE PIXEL

(84) Designated Contracting States:

**AT BE BG CH CY CZ DE DK EE ES FI FR GB GR
HR HU IE IS IT LI LT LU LV MC MT NL NO PL PT
RO SE SI SK TR**

(30) Priority: **10.12.2007 JP 2007318673**

(43) Date of publication of application:

29.09.2010 Bulletin 2010/39

(73) Proprietor: **Global OLED Technology LLC**

Herndon, VA 20171 (US)

(72) Inventor: **KAWABE, Kazuyoshi**

**Yokohama
Kanagawa 222-0033 (JP)**

(74) Representative: **Wibbelmann, Jobst**

**Wuesthoff & Wuesthoff
Patentanwälte PartG mbB
Schweigerstrasse 2
81541 München (DE)**

(56) References cited:

**US-A1- 2005 067 971 US-A1- 2005 243 035
US-A1- 2006 221 028 US-A1- 2007 001 205**

EP 2 232 557 B1

Note: Within nine months of the publication of the mention of the grant of the European patent in the European Patent Bulletin, any person may give notice to the European Patent Office of opposition to that patent, in accordance with the Implementing Regulations. Notice of opposition shall not be deemed to have been filed until the opposition fee has been paid. (Art. 99(1) European Patent Convention).

Description

FIELD OF THE INVENTION

[0001] The present invention relates to a pixel circuit of an organic EL display or the like.

BACKGROUND OF THE INVENTION

[0002] Because an organic EL display is of self-emissive type, it has high contrast and fast response, making it suitable for moving picture applications such as a television for displaying natural images. Generally, an organic EL element is driven at a constant current using a control element such as a transistor, but since the transistor in this case is used in the saturation region, different currents are generated in each pixel, even with the same gradation voltage (voltage step) supplied to the pixel, because of variations in V_{th} (threshold voltage) and mobility characteristics of the transistor, and it is not possible to keep the emission brightness uniform, which is a problem. In order to solve this problem, a structure having a circuit for compensating for V_{th} provided inside a pixel is disclosed in WO 1998048403.

SUMMARY OF THE INVENTION

[0003] FIG. 7 shows the pixel circuit disclosed in WO 1998048403. In FIG. 7, a gate of a p-channel switching transistor P4 having a source connected to a data line is connected to a gate line, and the drain of this transistor P4 is connected to the gate of a p-channel driving transistor P1 via a capacitor C_c . The source of the driving transistor P1 is connected to power supply VDD, while the drain is connected via a p-channel light emission controlling transistor P2 and the organic EL element OLED to a negative power supply. Also, a capacitor C_s is arranged between the gate of the driving transistor P1 and the power supply VDD, with a reset transistor P3 being arranged between the gate and source of the driving transistor P1.

[0004] With this structure, in a state where the light emission controlling transistor P2 has been turned off by the light emission control line, power supply potential VDD is supplied to the data line, the switching transistor P4 and the reset transistor P3 are turned on by the gate line and the reset line, and V_{th} is written to the capacitors C_c and C_s . Next, the reset transistor P3 is turned off to apply a data line gradation signal voltage V_{sig} to the gate of the driving transistor P1 via the capacitor C_c , and a gate voltage $V_g = C_c / (C_c + C_s) \times V_{sig} + V_{th}$ is applied to the gate terminal of the driving transistor P1.

[0005] In this way, since this V_{th} is always added to the gradation signal voltage as an offset at the gate terminal of the driving transistor, V_{th} is automatically corrected. However, since a dynamic range of the gradation signal voltage is reduced to $C_c / (C_c + C_s)$, it is preferable to make C_c sufficiently large compared to C_s in order to

avoid this. However, if C_c is made larger the surface area occupied by C_c in the pixel section increases, making the surface area of an opening section disadvantageously larger. As a result, the organic EL element is driven at a high current density, and it is difficult to ensure reliability, such as lifespan.

[0006] Document US 2006/0221028 A1 describes a drive control element which includes a first capacitor connected between the constant-potential terminal and the gate of a drive control element and a second capacitor connected to a video signal line.

[0007] Document US 2005/0243035 A1 describes a display device comprising a plurality of pixel circuits. At least one of the pixel circuits includes at least two emit elements, and a capacitor. The capacitor is disposed between the long sides of the emit elements. A power line extends in a column direction between some of the elements and is coupled to a polysilicon layer to supply power to a first electrode of the capacitor and to a source of a transistor.

[0008] Document US 2007/0001205 A1 describes a layout of a laterally separated light-emitting element, driving transistor, and capacitor.

[0009] It is also difficult to correct mobility with the V_{th} correction circuit of the related art disclosed in the above-mentioned document, and it is difficult to ensure high brightness uniformity in a wide gradation range when there are variations in mobility between pixels. Also, an organic EL element generally has reduced emission brightness accompanying light emission, but with the pixel circuit of the related art it is also not possible to correct the lowering of light emission brightness.

[0010] The present invention is directed to a (pixel) circuit

comprising a first storage capacitor having a first terminal connected to a data line, a switching transistor having a first terminal connected to this first storage capacitor and which is switched ON and OFF by a selection line, a driving transistor having a control terminal connected to a second terminal of the switching transistor and having a first terminal connected to a power supply, an organic electroluminescence element which is connected to a second terminal of the driving transistor through a light emission controlling transistor, a second storage capacitor which connects the control terminal of the driving transistor and a first power supply side terminal, and a reset transistor which connects a second terminal of the driving transistor on the side near the light emission controlling transistor and the control terminal of the driving transistor or the side of the first storage capacitor near the driving transistor, wherein the first storage capacitor is formed overlapping the data line. The first storage capacitor comprises a section where a semiconductor thin film constituting the switching transistor or the reset transistor extends, an insulating film formed with the same process as for a gate insulation film of the switching transistor or the reset transistor, and a metal layer formed with the same process as for the gate electrode of the switching

transistor or the reset transistor, wherein the metal layer and the data line are connected by a contact.

[0011] It is possible, after a voltage corresponding to a threshold voltage of the driving transistor has been written to the gate of the driving transistor, to turn off the switching transistor while the reset transistor and the light emission controlling transistor are turned on, and for a voltage obtained by voltage division of the power supply voltage by an organic electroluminescence element and the driving transistor to be written to the gate of the driving transistor by current flowing in the driving transistor.

[0012] In this way, according to the present invention, it is possible to form a storage capacitor overlapping a data line. Accordingly, obtaining a large capacitance storage capacitor is easy. In this way it is possible to easily perform threshold value compensation for the driving transistor.

BRIEF DESCRIPTION OF THE DRAWINGS

[0013]

FIG 1 is a drawing showing the structure of one example of a pixel circuit of the embodiments;

FIG 2A is a plan view showing the structure of a first storage capacitor;

FIG 2B is a cross sectional view showing the structure of the first storage capacitor;

FIG 2C is a cross sectional view showing another structural example of the first storage capacitor;

FIG 3 is a drawing showing the structure of another example of a pixel circuit of the embodiments;

FIG 4 is a timing chart showing an example of states of each line;

FIG 5 is a timing chart showing another example of states of each line;

FIG 6 is a timing chart showing a further example of states of each line; and

FIG 7 is a drawing showing the structure of a pixel circuit of the related art.

DESCRIPTION OF THE PREFERRED EMBODIMENTS

[0014] Embodiments of the present invention will be described in the following based on the drawings. A pixel circuit for the pixel 14 of this embodiment is shown in FIG 1. An organic EL element 1 has its cathode connected to a cathode electrode 13 common to all pixels (for supplying VSS), and its anode connected to a drain terminal of a light emission controlling transistor 5 having a gate terminal connected to a light emission control line 12. A source terminal of the light emission controlling transistor 5 is connected to a drain terminal of a driving transistor 2 having a source connected to a power supply line 9 common to all pixels (for supplying VDD).

[0015] A source terminal of a reset transistor 4 having a gate terminal connected to a reset line 11 is connected

to a connection point of the light emission controlling transistor 5 and the driving transistor 2, while the drain terminal of the reset transistor 4 is connected to one end of a first storage capacitor 6 having its other end connected to a data line 8, and to a drain terminal of a switching transistor 3 that has its gate terminal connected to a gate line 10. The source terminal of the switching transistor 3 is connected to a gate terminal of the driving transistor 2 and to one end of a second storage capacitor 7 that has its other end connected to a power supply line 9, to thus constitute the pixel 14.

[0016] The first storage capacitor 6 has a capacitance value C_c , and the second storage capacitor 7 has a capacitance value C_s . The fact that it is preferable, in preventing reduction in dynamic range of a gradation signal voltage V_{sig} supplied to the data line 8, to make the capacitance value C_c of the first storage capacitor large compared to the capacitance value C_s of the second storage capacitor has been described previously. With this embodiment, the pixel 14 is constructed so that it is possible to ensure that the capacitance C_c is sufficiently large, because it is possible to form the first storage capacitor 6 by coupling with the data line 8.

[0017] FIG. 2A and 2B show an example of the first storage capacitor 6 formed along the data line 8. One end of the first storage capacitor 6 is connected to the data line 8, while the other end is connected to drain terminals of the switching transistor 3 and the reset transistor 4. It is therefore convenient to form the capacitor with a polysilicon thin film doped with impurities, wherein it is possible to use one end of the first storage capacitor 6 as the data line and to use the other end as drain terminals of the switching transistor 3 and the reset transistor 4.

[0018] Here, the first storage capacitor 6 shown in FIG 2A and FIG. 2B is formed by sandwiching a gate insulating film with a gate element and a polysilicon thin film that has been doped with impurities, and the gate insulating film is formed on the polysilicon thin film that has been doped with impurities, and metal of the data line 8 is formed on thus gate insulating film by way of gate metal and a further interlayer insulating film. In this way the first storage capacitor 6 is formed based on a general polysilicon process. Then as shown in the cross section A-A', by connecting the data line 8 and the gate metal by way of a contact, one end of the first storage capacitor constitutes the data line 8 and the other end constitutes the polysilicon thin film that has been doped with impurities, and the first storage capacitor 6 shown in FIG 2A and FIG. 2B functions as the storage capacitor 6 of FIG 1.

[0019] The polysilicon thin film that has been doped with impurities is formed by extending the drain terminals of the switching transistor 3 and the reset transistor 4, and the gate metal of the first storage capacitor 6 is formed by the same process as the gate electrodes of the transistors, but they are electrically isolated. A central section of the polysilicon thin film is a channel region that is basically not doped with impurities, and there are a

drain region and a source region at either side that are doped with impurities, and by arranging the gate electrode on the channel region via a gate insulating film a transistor is formed.

[0020] By configuring a pixel circuit in this way, it is possible to form the first storage capacitor 6 using a coupling with the data line 8, which shows that by forming the first storage capacitor 6 along the data line 8 it is possible to make the capacitance value C_c of the storage capacitor 6 sufficiently large.

[0021] The storage capacitor 6 can also be formed by way of an interlayer insulating film, in addition to by way of the gate insulating film, and in addition to polysilicon doped with impurities the metal functioning as the terminals of the storage capacitor can use gate metal etc. More specifically, by not forming the contact between the data line and the gate metal as shown in FIG 2B, and connecting the gate metal to the polysilicon thin film that has been doped with impurities and used as drain electrodes for the switching transistor 3 and the reset transistor 4, an area, where the gate metal and the data line 8 opposing via the interlayer insulation film functions also as the storage capacitor 6.

[0022] For example, with the configuration of FIG 2C, the polysilicon thin film that has been doped with impurities is connected to the data line 8. This polysilicon thin film that has been doped with impurities is isolated from the drain terminals of the switching transistor 3 and the reset transistor 4. On the other hand, the gate metal is connected to the drain terminals of the switching transistor 3 and the reset transistor 4 by contacts. In this manner, both between the gate metal and the data line, and between the gate metal and the polysilicon thin film doped with impurities, function as the first storage capacitor 6.

[0023] An example of another pixel 14 of the present invention is shown in FIG 3. A point of difference from FIG. 1 is that the drain terminal of the reset transistor 4, is connected to the gate terminal of the driving transistor 2, the end of the second storage capacitor 7 that is not connected to the power supply line 9, and the source terminal of the switching transistor 3. In this pixel 14 also, by using the control method that will be described next it is possible to correct V_{th} of the driving transistor 2.

[0024] A control method for correcting V_{th} of the driving transistor 2 using the pixel 14 of FIG 1 and FIG 3 is shown in FIG 4. As shown in FIG 4, a horizontal period is divided into a reset period and a data write period, and the operation of the pixel 14 is different in each period.

[0025] In a horizontal period in which the line of the pixel 14 is selected, the gate line 10 is selected, but in the initial reset period the reset line 11 is first set Low. As a result, the switching transistor 3 and the reset transistor 4 are turned on, and the driving transistor 2 is diode connected causing current to flow in the organic EL element 1. After that, the current that is flowing in the organic EL element 1 is made to flow via the reset transistor 4 to the first and second storage capacitors 6 and 7 by setting the light emission control line 12 to High. While this is

happening the same power supply voltage VDD as on the power supply line 9 is supplied to the data line 8, and so by the time a certain time has elapsed and current no longer flows V_{th} is held at the first and second storage capacitors 6 and 7. Since the reset transistor 4 is turned off by setting the reset transistor 11 High at this time, the potential held at the first and second storage capacitors 6 and 7 is settled, and the reset period is completed.

[0026] After that, if the gradation control voltage V_{sig} is supplied to the data line 8, the gate voltage V_g of the driving transistor 2 is controlled to $V_g = C_c / (C_c + C_s) * V_{sig} + V_{th}$ by adding a potential that is proportional to the gradation signal voltage V_{sig} to V_{th} using coupling with the first coupling capacitor 6, and V_{th} of the driving transistor 2 is corrected. However, the previously described reset period does not have to be maintained until there is substantially no current flow in the driving transistor 2, and can be an appropriate time such as a few μs to a few tens of μs .

[0027] The capacitance C_c of the first storage capacitor 6 is sufficiently larger than the capacitance C_s of the second storage capacitor 7, which shows that $C_c / (C_c + C_s)$ is substantially equal to 1, and the dynamic range of the gradation signal voltage V_{sig} is maintained.

[0028] Once the horizontal period is completed, the light emission control line is made Low, a current corresponding to the written gradation signal voltage V_{sig} flows in the organic EL element 1 via the light emission controlling transistor 5, and light emission is maintained until the line of the next pixel 14 is selected.

[0029] V_{th} is corrected by controlling the pixel 14 as described above, but if the mobility of the driving transistor 2 is different for every pixel, current flowing in the organic EL element 1 will vary even if it is possible to correct only V_{th} . Therefore, a voltage difference arises between pixels, and brightness uniformity is deteriorated. Consequently, brightness variation due to differences in mobility are corrected by controlling the pixel 14 of FIG 1 as described in the following.

[0030] FIG. 5 shows a control method for performing mobility correction in addition to V_{th} correction. Differing from FIG. 4, the horizontal period is divided into 4, namely a reset period, a first data write period, a current difference extraction period, and a second data write period. In the reset period, similar to FIG 4, when the gate line 10 of the pixel 14 is selected the driving transistor 2 is diode connected by setting the reset line 11 to Low, and current temporarily flows in the organic EL element. Next, by setting the light emission control line 12 to High a current path to the organic EL element 1 is cut off, current continues to flow into the first and second storage capacitors 6 and 7, and V_{th} is written (reset period).

[0031] After that, if the reset line 11 is set to High, V_{th} written to the first and second storage capacitors 6 and 7 is settled, and by supplying the gradation signal voltage V_{sig} to the data line 8 V_{th} is corrected at the gate voltage of the driving transistor 2 and a potential $V_g = C_c / (C_c + C_s) * V_{sig} + V_{th}$ that is the gradation signal voltage V_{sig}

inverted is generated. Therefore, a current with V_{th} corrected is made to flow in the organic EL element 1 by setting the light emission control line 12 to Low (first data write period).

[0032] Here, once the gate line 10 is set High, current with V_{th} corrected continues to flow even if deselected. If the reset line 11 is set Low at this time, the potential stored at the first storage capacitor 6 varies in accordance with current flowing in the organic EL element 1. That is, if the reset line 11 is set Low, current flows from the first storage capacitor 6 to the organic EL element 1 via the reset transistor 4, but if a large current is flowing in the organic EL element 1 (mobility of the driving transistor 2 is high) the voltage across the source and drain of the reset transistor 4 becomes smaller which shows that a current discharged from the first storage capacitor 6 becomes small, while if the current flowing in the organic EL element 1 (mobility of the driving transistor 2 is low) the voltage across the source and drain of the reset transistor 4 becomes high causing the current discharged from the first storage capacitor 6 to be large.

[0033] Once the current difference extraction period in which the reset line 11 is made Low elapses and the reset line 11 is set High, the potential on a reset transistor side end of the first storage transistor 6 becomes a higher potential in the event that the mobility of the driving transistor 2 is high, or a lower potential in the event that the mobility of the driving transistor 2 is low, and a potential corresponding to the mobility of the driving transistor 2 is reflected at the first storage capacitor 6 (current difference extraction period).

[0034] If this type of mobility correction is carried out, the gate line 10 is selected again, and the potential reflected at the first storage capacitor 6 is written to the second storage capacitor 7 (second data write period). In this way, in the event that the mobility of the driving transistor 2 is high, a higher potential is written to the second storage capacitor 7 to suppress the current of the driving transistor 2, while if the mobility is low a lower potential is written to the second storage capacitor 7 to stimulate the current of the driving transistor 2.

[0035] Since the gradation signal voltage V_{sig} continues to be supplied to the data line 8 except in the reset period, the same mobility correction is carried out at all gradations, but because the source drain voltage of the reset transistor 4 becomes large in the current difference extraction period and a required current or greater flows from the first storage capacitor 6 in the case of low gradation, it is preferable that the current difference extraction period not be too long. Alternatively, it is possible to make the Low level of the reset line 11 comparatively high, and make the on resistance of the reset transistor 4 large, or to lengthen the channel length of the reset transistor 4 and increase the on resistance to avoid excessive current flowing.

[0036] If the pixel 14 of FIG 1 is controlled as described above, it is possible to correct not only V_{th} but also mobility, but if the organic EL element 1 deteriorates and

becomes high resistance, then at the time of current difference extraction the source drain voltage of the reset transistor 4 is affected more by the raise in voltage of the organic EL element 1, which shows that the above described mobility correction no longer functions appropriately. It is therefore preferable to perform the following homogenization processing for the organic EL element 1.

[0037] FIG. 6 shows a control method for carrying out homogenization processing for the organic EL element 1 using the pixel 14 of FIG 1. The procedure of the homogenization processing is the same as for FIG. 5, in that the horizontal period is divided into 4 periods, namely a reset period, a first data write period, a current difference extraction period, and a second data write period. If the same reset period as in FIG. 4 and FIG. 5 is completed and V_{th} is written to the first and second storage capacitors 6 and 7, the cathode potential VSS is supplied to the data line 8 (it can also be a low voltage corresponding to VSS), and by writing to the second storage capacitor 7 the first data write period is completed. In this way, the gate voltage of the driving transistor 2 becomes sufficiently low, and the driving transistor 2 operates in the linear region. If the gate line 10 becomes High in the current difference extraction period and is unselected, the second storage capacitor 7 is isolated from the first storage capacitor 6 and by setting the reset line 11 and the light emission control line 12 Low a potential that is voltage divided by the organic EL element 1 and the on resistance of the driving transistor 2 is written to a reset transistor side terminal of the first storage capacitor 6.

[0038] If the organic EL element 1 is degraded and its resistance becomes high, the current flowing from the power supply line 9 to the organic EL element 1 becomes small and the drain potential of the driving transistor 2 during an on operation rises because voltage lowering becomes small. In the event that there is low degradation, the current flowing from the power supply line 9 to the organic EL element 1 increases, and as a result the drain potential of the driving transistor 2 during an on operation falls with large lowering of voltage. The drain potential of the driving transistor 2 is written via the reset transistor 4 to the first storage capacitor 6, which shows that degradation of the organic EL elements 1 is reflected to the first storage capacitor 6. Alternatively, it is also possible to reflect degradation of the organic EL element 1 at the first storage capacitor 6 by supplying the VDD potential (or a potential higher than VDD) to the data line 8 in the first data write period after the reset period is completed, and writing to the second storage capacitor 7 to reliably turn off the driving transistor 2. That is, if the reset transistor 4 and the light emission controlling transistor 5 are turned on in a state where the driving transistor 2 is off, current flows from the data line 8 that is maintained at VDD, through the first storage capacitor 6, the reset transistor 4 and the light emission controlling transistor 5, to the organic EL element 1, which shows that the anode potential of the organic EL element 1 is reflected at one end of the first storage capacitor 6, and a potential cor-

responding to the extent of degradation is maintained at the first storage capacitor 6 by turning the reset transistor 4 off at an appropriate time. In this case also, it becomes difficult for current to flow if degradation is significant, which shows that the anode potential of the organic EL element 1 becomes high, while if degradation is low it is easy for current to flow which shows that the anode potential becomes low, and these differences are reflected at the first storage capacitor 6.

[0039] In the second data write period, the gate line 10 is again made Low, drive potential of the organic EL element 1 that has been written to the first storage capacitor 6 and the gradation control signal Vsig supplied to the data line 8 are written to the second storage capacitor 7 by way of coupling of the first storage capacitor 6, and a potential that reflects degradation of the first organic EL element 1 is maintained at the gate terminal of the driving transistor 2. That is, in a pixel that has significant degradation there is a higher gate voltage, and in a pixel with slight degradation there is a lower gate voltage. By setting the light emission control line 12 low, current that has been subjected to homogenization that differs for each organic EL element 1 according to the extent of degradation flows with a smaller current flowing in pixels with significant degradation and a larger current flowing in pixels that have slight degradation, thus performing uniformity of degradation. The fact that the gradation signal voltage Vsig supplied to the data line 8 in the second data write period determines current flowing in all pixels at the time of homogenization processing is arbitrary, and it is preferable to set so that a particular current flows, because degradation is accelerated if too much current flows.

[0040] This homogenization processing is carried out at, for example, about 60 Hz so as to achieve normal display. The state of degradation of the organic EL element 1 for every frame period is read in the current difference extraction period, and is reflected in the homogenized current, which shows that homogenized current is automatically adjusted. Specifically, as a result of homogenization processing, pixels with accelerated degradation have homogenized current moderated, and ultimately the same current flows in all pixels.

[0041] Homogenization processing is preferably carried out in a separate period from the normal image display period, but it is also possible to divide a frame into a plurality of subframes, and perform normal display in an initial sub-frame, and after that carry out homogenization processing in the next subframe. In this case, it is preferable for the homogenization processing to set the homogenization current to an extent that does not affect display.

[0042] Generally, degradation in the light emission intensity of an organic EL element is closely related to the previously described resistance increase, which shows that as well as equalizing the drive voltage using the homogenization processing it is also possible to anticipate homogenization of degradation in light emission intensi-

ty, and it is possible to prevent burn-in.

PARTS LIST

5 [0043]

1	organic EL element
2	driving transistor
3	switching transistor
10 4	reset transistor
5	light emission controlling transistor
6	first storage capacitor
7	second storage capacitor
8	data line
15 9	power supply line
10	gate line
11	reset line
12	light emission control line
13	cathode electrode
20 14	pixel
P1	driving transistor
P2	p-channel light emission controlling transistor
P3	reset transistor
P4	p-channel switching transistor

25

Claims

- 30 1. A pixel circuit (14) for an electroluminescent element (1) comprising:

a data line (8) and a power supply (9; VDD);
 a first storage capacitor (6) having a first terminal connected to the data line (8);
 35 a switching transistor (3) having a first terminal connected to the first storage capacitor (6) and which is switched ON and OFF by a gate line (10) connected to a control terminal;
 a driving transistor (2) having a control terminal connected to a second terminal of the switching transistor (3) and having a first terminal connected to the power supply (9; VDD);
 40 an organic electroluminescence element (1) which is connected to the second terminal of the driving transistor (2) through a light emission controlling transistor (5);
 a second storage capacitor (7) which connects the control terminal of the driving transistor (2) and a first power supply side terminal; and
 45 a reset transistor (4) which connects a second terminal of the driving transistor (2) on the side near the light emission controlling transistor (5) and the control terminal of the driving transistor (2) or the side of the first storage capacitor (6)
 50 near the driving transistor (2),

55

characterized in that the first storage capacitor (6) is formed overlapping the data line (8), wherein the

first storage capacitor (6) comprises
 a section where a semiconductor thin film constituting the switching transistor (3) or the reset transistor (4) extends;
 an insulating film formed with the same process as for the gate insulation film of the switching transistor (3) or the reset transistor (4); and
 a metal layer formed with the same process as for the gate electrode of the switching transistor (3) or the reset transistor (4), wherein the metal layer and the data line (8) are connected by a contact.

2. A display comprising pixel circuits according to claim 1, further comprising a control unit adapted to:

turn off the switching transistor (3), after a voltage corresponding to a threshold voltage (V_{th}) of the driving transistor (2) has been written to the gate of the driving transistor (2), while the reset transistor (4) and the light emission controlling transistor (5) are turned on, and
 set a voltage corresponding to the voltage of an organic electroluminescence element side terminal of the driving transistor (2) at the gate of the driving transistor (2) by current flowing in the driving transistor (2).

Patentansprüche

1. Pixelschaltung (14) für ein elektrolumineszentes Element (1), umfassend:

eine Datenleitung (8) und eine Stromzufuhr (9; VDD);
 einen ersten Speicherkondensator (6) mit einem ersten Anschluss, der mit der Datenleitung (8) verbunden ist;
 einen Schalttransistor (3) mit einem ersten Anschluss, der mit dem ersten Speicherkondensator (6) verbunden ist und der durch eine Gate-Leitung (10) ein- und ausgeschaltet wird, die mit einem Steueranschluss verbunden ist;
 einen Treibertransistor (2) mit einem Steueranschluss, der mit einem zweiten Anschluss des Schalttransistors (3) verbunden ist, und mit einem ersten Anschluss, der mit der Stromzufuhr (9; VDD) verbunden ist;
 ein organisches, elektrolumineszentes Element (1), das mit dem zweiten Anschluss des Treibertransistors (2) durch einen Lichtemissionssteuertransistor (5) verbunden ist;
 einen zweiten Speicherkondensator (7), der den Steueranschluss des Treibertransistors (2) und einen ersten stromzufuhrseitigen Anschluss verbindet; und
 einen Rücksetztransistor (4), der einen zweiten Anschluss des Treibertransistors (2) auf der Sei-

te nahe dem Lichtemissionssteuertransistor (5) und den Steueranschluss des Treibertransistors (2) oder die Seite des ersten Speicherkondensators (6) nahe dem Treibertransistor (2) verbindet,

dadurch gekennzeichnet, dass der erste Speicherkondensator (6) ausgebildet ist, indem er die Datenleitung (8) überlappt, wobei der erste Speicherkondensator (6) umfasst einen Abschnitt, in dem sich ein Halbleiterdünnfilm erstreckt, der den Schalttransistor (3) oder den Rücksetztransistor (4) bildet;
 einen isolierenden Film, der mit demselben Prozess wie für den Gate-Isolationsfilm des Schalttransistors (3) oder des Rücksetztransistors (4) ausgebildet wird; und
 eine Metallschicht, die mit demselben Prozess wie für die Gate-Elektrode des Schalttransistors (3) oder des Rücksetztransistors (4) ausgebildet wird, wobei die Metallschicht und die Datenleitung (8) durch einen Kontakt verbunden sind.

2. Anzeige, die Pixelschaltung gemäß Anspruch 1 umfasst und die weiterhin eine Steuereinheit umfasst, die eingerichtet ist, um:

den Schalttransistor (3) auszuschalten, nachdem eine Spannung entsprechend einer Schwellspannung (V_{th}) des Schalttransistors (2) auf das Gate des Treibertransistors (2) geschrieben wurde, während der Rücksetztransistor (4) und der Lichtemissionssteuertransistor (5) eingeschaltet sind, und
 eine Spannung entsprechend der Spannung eines Anschlusses des Treibertransistors (2) auf Seiten des organischen elektrolumineszenten Elements bei dem Gate des Treibertransistors (2) durch einen Strom zu setzen, der in dem Treibertransistor (2) fließt.

Revendications

1. Circuit de pixels (14) destiné à un élément électroluminescent (1) comprenant :

une ligne de données (8) et une alimentation électrique (9 ; VDD) ;
 un premier condensateur de stockage (6) doté d'un premier terminal relié à la ligne de données (8) ;
 un transistor de commutation (3) doté d'un premier terminal relié au premier condensateur de stockage (6) et qui est allumé et éteint par une ligne de grille (10) reliée à un terminal de commande ;
 un transistor d'entraînement (2) doté d'un terminal de commande relié à un second terminal du

transistor de commutation (3) et doté d'un premier terminal relié à l'alimentation électrique (9 ; VDD) ;
 un élément électroluminescent organique (1) qui est relié au second terminal du transistor d'entraînement (2) par le biais d'un transistor de commande d'émission de lumière (5) ;
 un second condensateur de stockage (7) qui relie le terminal de commande du transistor d'entraînement (2) à un premier terminal côté alimentation électrique ; et
 un transistor de réinitialisation (4) qui relie un second terminal du transistor d'entraînement (2) sur le côté près du transistor de commande d'émission de lumière (5) et le terminal de commande du transistor d'entraînement (2) ou le côté du premier condensateur de stockage (6) près du transistor d'entraînement (2),
caractérisé en ce que le premier condensateur de stockage (6) est formé de façon à chevaucher la ligne de données (8), dans lequel le premier condensateur de stockage (6) comprend :

une section où s'étend un film mince à semi-conducteur composant le transistor de commutation (3) ou le transistor de réinitialisation (4) ;
 un film isolant formé avec le même processus que pour le film isolant de grille du transistor de commutation (3) ou du transistor de réinitialisation (4) ; et
 une couche métallique formée avec le même processus que pour l'électrode de grille du transistor de commutation (3) ou du transistor de réinitialisation (4), dans lequel la couche métallique et la ligne de données (8) sont reliées par un contact.

2. Écran comprenant des circuits de pixels selon la revendication 1, comprenant en outre une unité de commande adaptée pour :

éteindre le transistor de commutation (3), après qu'une tension correspondant à une tension de seuil (V_{th}) du transistor d'entraînement (2) a été écrite sur la grille du transistor d'entraînement (2), tandis que le transistor de réinitialisation (4) et le transistor de commande d'émission de lumière (5) sont allumés, et
 régler une tension correspondant à la tension d'un terminal coté élément électroluminescent organique du transistor d'entraînement (2) au niveau de la grille du transistor d'entraînement (2) par un courant s'écoulant dans le transistor d'entraînement (2).

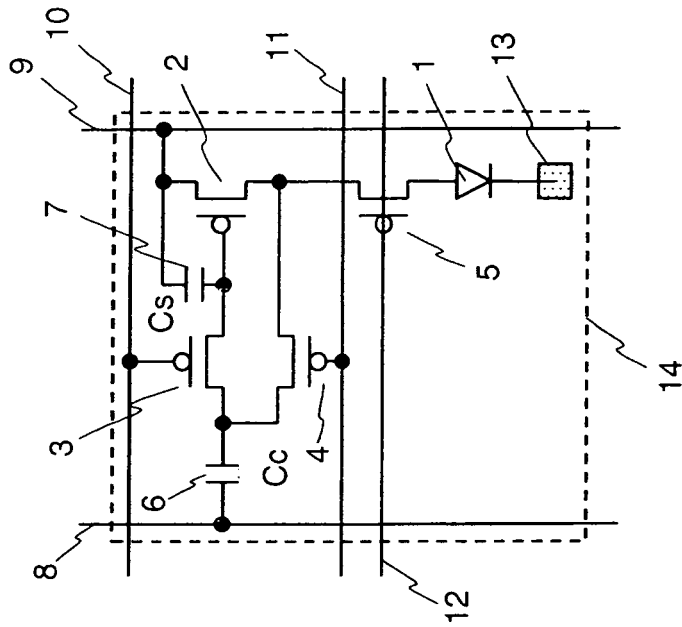
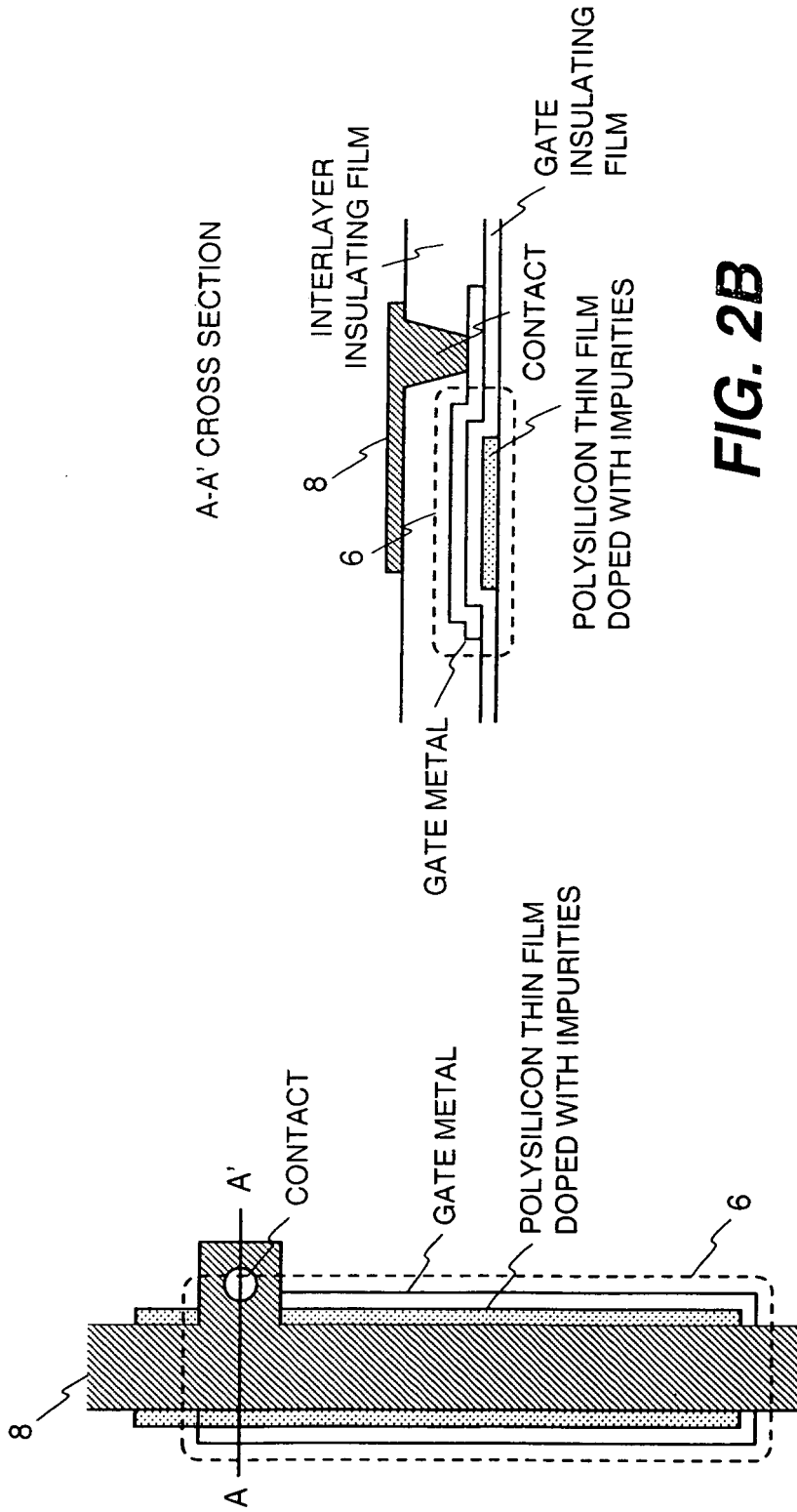

FIG. 1



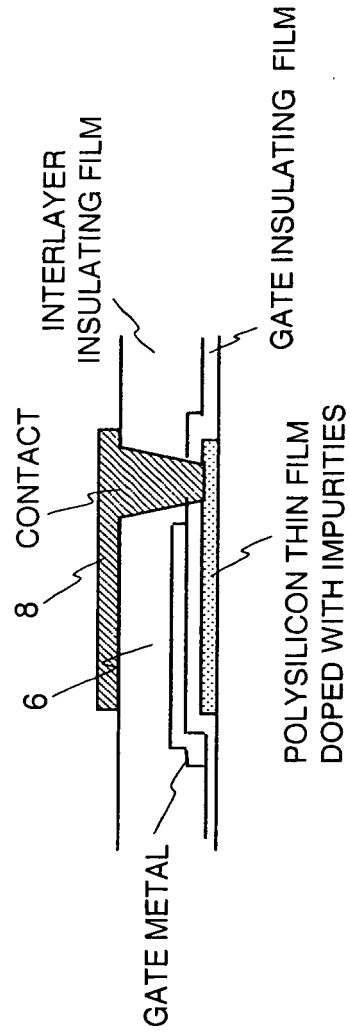

FIG. 2C

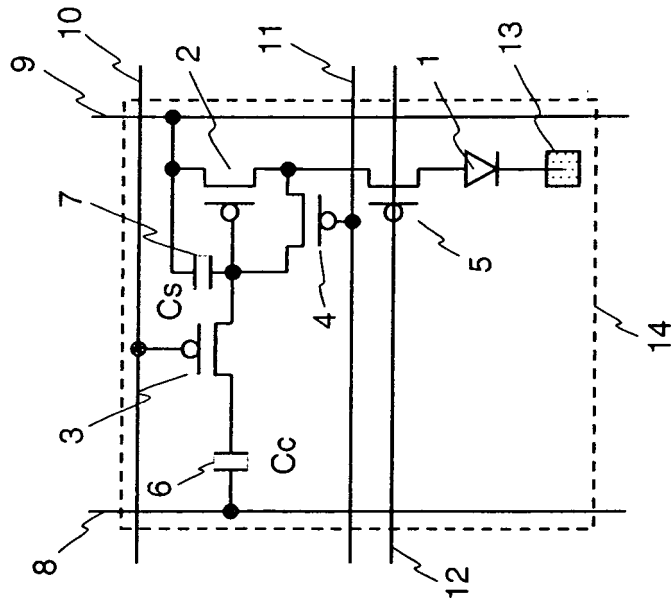

FIG. 3

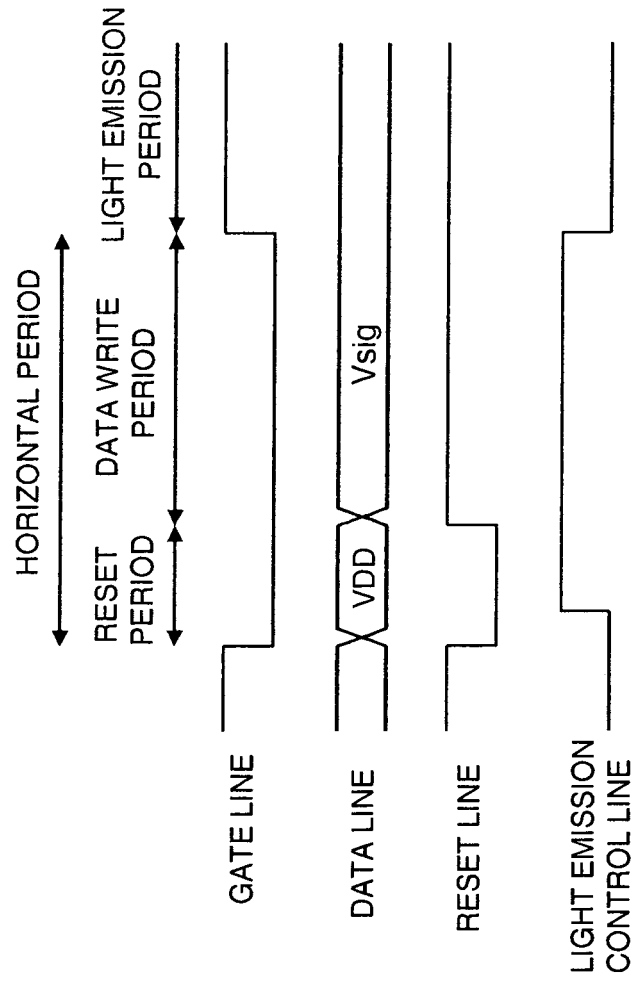

FIG. 4

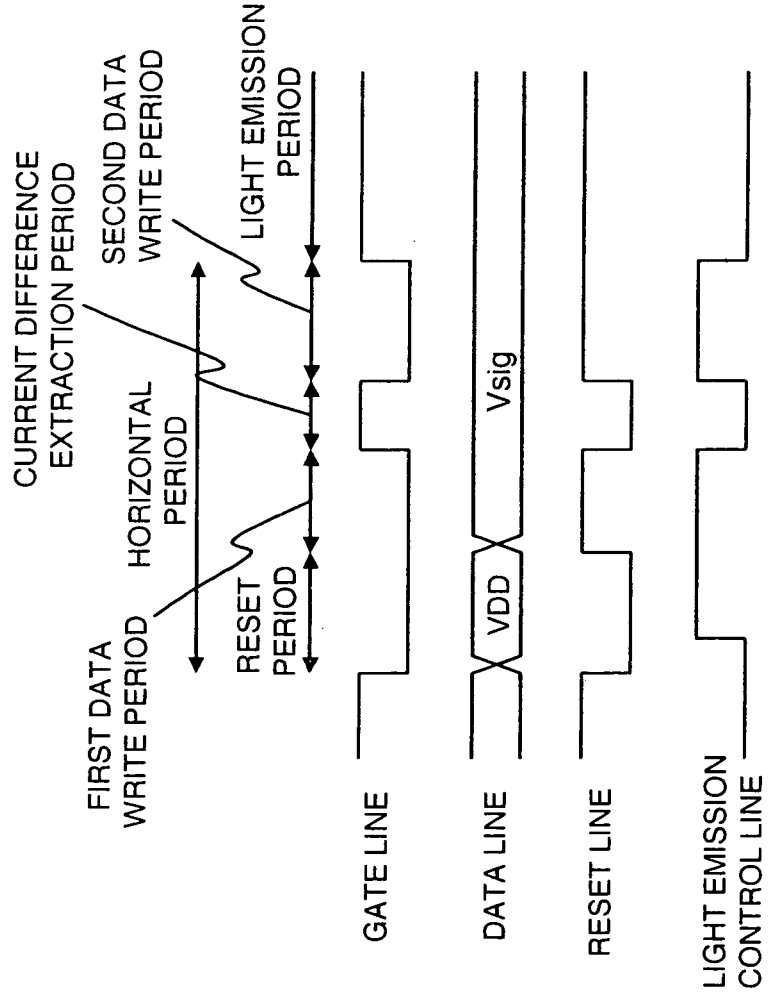

FIG. 5

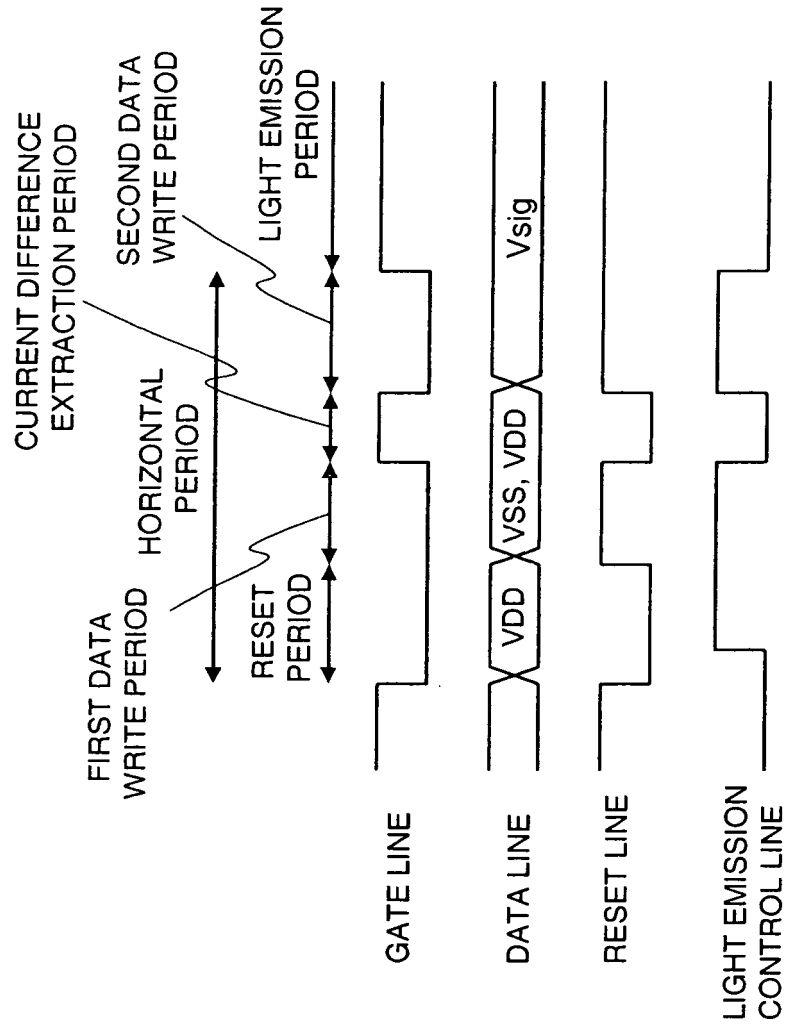

FIG. 6

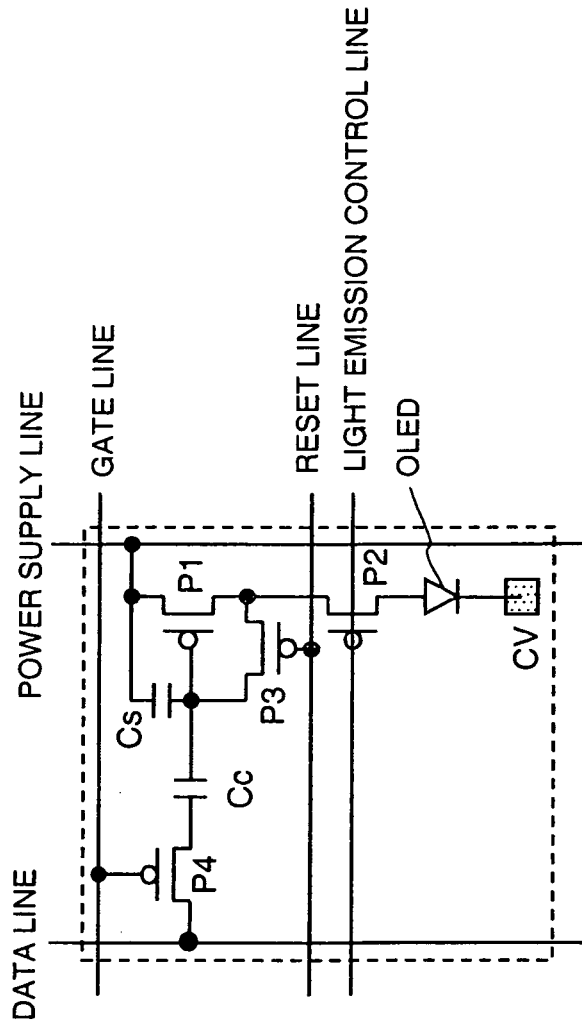

FIG. 7
PRIOR ART

REFERENCES CITED IN THE DESCRIPTION

This list of references cited by the applicant is for the reader's convenience only. It does not form part of the European patent document. Even though great care has been taken in compiling the references, errors or omissions cannot be excluded and the EPO disclaims all liability in this regard.

Patent documents cited in the description

- WO 1998048403 A [0002] [0003]
- US 20060221028 A1 [0006]
- US 20050243035 A1 [0007]
- US 20070001205 A1 [0008]

专利名称(译)	像素电路		
公开(公告)号	EP2232557B1	公开(公告)日	2017-05-03
申请号	EP2008859715	申请日	2008-12-01
[标]申请(专利权)人(译)	全球OLED TECH		
申请(专利权)人(译)	全球OLED科技有限责任公司		
当前申请(专利权)人(译)	全球OLED科技有限责任公司		
[标]发明人	KAWABE KAZUYOSHI		
发明人	KAWABE, KAZUYOSHI		
IPC分类号	H01L27/32 G09G3/32		
CPC分类号	G09G3/3233 G09G2300/0819 G09G2300/0852 G09G2300/0861 G09G2310/0262 H01L27/3265 G09G3/30 G09G3/32		
优先权	2007318673 2007-12-10 JP		
其他公开文献	EP2232557A1		
外部链接	Espacenet		

摘要(译)

为了有效地执行用于电致发光元件的驱动晶体管的阈值补偿。第一存储电容器具有连接到数据线的第一端子。开关晶体管的第一端子和复位晶体管的第一端子连接到第一存储电容器的第二端子。第一存储电容器成为与数据线重叠。

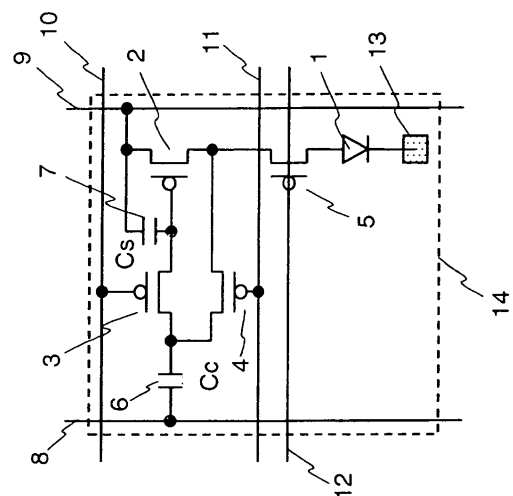

FIG. 1