



(11) **EP 1 873 744 A1**

(12) **EUROPEAN PATENT APPLICATION**

(43) Date of publication:
02.01.2008 Bulletin 2008/01

(51) Int Cl.:
G09G 3/32^(2006.01)

(21) Application number: **06300737.1**

(22) Date of filing: **30.06.2006**

(84) Designated Contracting States:
AT BE BG CH CY CZ DE DK EE ES FI FR GB GR HU IE IS IT LI LT LU LV MC NL PL PT RO SE SI SK TR
Designated Extension States:
AL BA HR MK YU

(72) Inventors:
• **Weitbruch, Sébastien**
92648 Boulogne Cedex (FR)
• **Doser, Ingo Tobias**
92648 Boulogne Cedex (FR)
• **Thiebaud, Sylvain**
92648 Boulogne Cedex (FR)

(71) Applicants:
• **Deutsche Thomson Brandt**
78048 Villingen (DE)
• **Thomson Licensing**
92100 Boulogne-Billancourt (FR)

(74) Representative: **Le Dantec, Claude**
46, Quai Alphonse Le Gallo
92100 Boulogne-Billancourt (FR)

(54) **Active matrix organic light emitting display (amOLED) device**

(57) The present invention relates to an active matrix OLED (Organic Light Emitting Display) device. It comprises a matrix of luminous elements associated to different colour components (red, green, blue). According

to the invention, the connection of the row driver (20) and/or data driver (30) to the luminous elements of the matrix is modified. Each output of the row driver is connected to luminous element associated to a same colour component (red or green or blue)

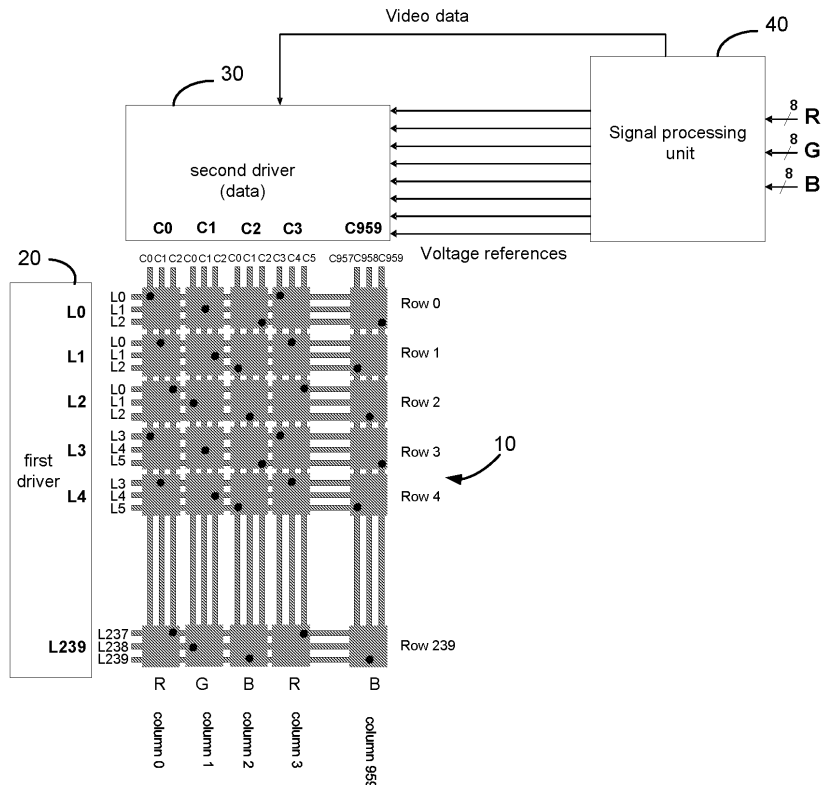

FIG. 11

EP 1 873 744 A1

Description

[0001] The present invention relates to an active matrix OLED (Organic Light Emitting Display) device. This device has been more particularly but not exclusively developed for video application.

Background of the invention

[0002] The structure of an active matrix OLED or AM-OLED is well known. It comprises:

- an active matrix containing, for each cell, an association of several thin film transistors (TFT) with a capacitor connected to an OLED material; the capacitor acts as a memory component that stores a value during a part of the video frame, this value being representative of a video information to be displayed by the cell during the next video frame or the next part of the video frame; the TFTs act as switches enabling the selection of the cell, the storage of a data in the capacitor and the displaying by the cell of a video information corresponding to the stored data;
- a row or gate driver that selects line by line the cells of the matrix in order to refresh their content;
- a column or source driver that delivers the data to be stored in each cell of the current selected line; this component receives the video information for each cell; and
- a digital processing unit that applies required video and signal processing steps and that delivers the required control signals to the row and column drivers.

[0003] Actually, there are two ways for driving the OLED cells. In a first way, each piece of digital video information sent by the digital processing unit is converted by the column drivers into a current whose amplitude is proportional to the video information. This current is provided to the appropriate cell of the matrix. In a second way, the digital video information sent by the digital processing unit is converted by the column drivers into a voltage whose amplitude is proportional to the video information. This current or voltage is provided to the appropriate cell of the matrix.

[0004] From the above, it can be deduced that the row driver has a quite simple function since it only has to apply a selection line by line. It is more or less a shift register. The column driver represents the real active part and can be considered as a high level digital to analog converter. The displaying of video information with such a structure of AM-OLED is the following one. The input signal is forwarded to the digital processing unit that delivers, after internal processing, a timing signal for row selection to the row driver synchronized with the data sent to the column drivers. The data transmitted to the column driver are either parallel or serial. Additionally, the column driver disposes of a reference signalling delivered by a separate reference signalling device. This component delivers a set of reference voltages in case of voltage driven circuitry or a set of reference currents in case of current driven circuitry. The highest reference is used for the white and the lowest for the black level. Then, the column driver applies to the matrix cells the voltage or current amplitude corresponding to the data to be displayed by the cells.

[0005] In order to illustrate this concept, an example of a voltage driven circuitry is described below. Such a circuitry will also be used in the rest of the present specification for illustrating the invention. The driver taken as example uses 8 reference voltages named V_0 to V_7 and the video levels are built as shown below:

Video level	Grayscale voltage level	Output voltage
0	V_7	0.00V
1	$V_7+(V_6-V_7) \times 9/1175$	0.001V
2	$V_7+(V_6-V_7) \times 32/1175$	0.005V
3	$V_7+(V_6-V_7) \times 76/1175$	0.011V
4	$V_7+(V_6-V_7) \times 141/1175$	0.02V
5	$V_7+(V_6-V_7) \times 224/1175$	0.032V
6	$V_7+(V_6-V_7) \times 321/1175$	0.045V
7	$V_7+(V_6-V_7) \times 425/1175$	0.06V
8	$V_7+(V_6-V_7) \times 529/1175$	0.074V
9	$V_7+(V_6-V_7) \times 630/1175$	0.089V
10	$V_7+(V_6-V_7) \times 727/1175$	0.102V
11	$V_7+(V_6-V_7) \times 820/1175$	0.115V

EP 1 873 744 A1

(continued)

5
10
15
20
25
30

Video level	Grayscale voltage level	Output voltage
12	$V7+(V6-V7) \times 910/1175$	0.128V
13	$V7+(V6-V7) \times 998/1175$	0.14V
14	$V7+(V6-V7) \times 1086/1175$	0.153V
15	V6	0.165V
16	$V6+(V5-V6) \times 89/1097$	0.176V
17	$V6+(V5-V6) \times 173/1097$	0.187V
18	$V6+(V5-V6) \times 250/1097$	0.196V
19	$V6+(V5-V6) \times 320/1097$	0.205V
20	$V6+(V5-V6) \times 386/1097$	0.213V
21	$V6+(V5-V6) \times 451/1097$	0.221V
22	$V6+(V5-V6) \times 517/1097$	0.229V
...
250	$V1+(V0-V1) \times 2278/3029$	2.901V
251	$V1+(V0-V1) \times 2411/3029$	2.919V
252	$V1+(V0-V1) \times 2549/3029$	2.937V
253	$V1+(V0-V1) \times 2694/3029$	2.956V
254	$V1+(V0-V1) \times 2851/3029$	2.977V
255	V0	3.00V

[0006] A more complete table is given in Annex 1. This table illustrates the output voltage for various input video levels. The reference voltages used are for example the following ones:

35
40
45

Reference V_n	Voltage (Volts)
V0	3
V1	2.6
V2	2.2
V3	1.4
V4	0.6
V5	0.3
V6	0.16
V7	0

[0007] Actually, there are three ways for making colour displays:

50
55

- a first possibility illustrated by figure 1 is to use a white OLED emitter having on top photopatternable colour filters; this type of display is similar to the current LCD displays where the colour is also done by using colour filters; it has the advantage of using one single OLED material deposition and of having a good colour tuning possibility but the efficiency of the whole display is limited by the colour filters.
- a second possibility illustrated by figure 2 is to use blue OLED emitters having on top photopatternable colour converters for red and green; such converters are mainly based on materials that absorb a certain spectrum of light and convert it to an other spectrum that is always lower; this type of display has the advantage of using one single OLED material deposition but the efficiency of the whole display is limited by the colour converters; furthermore,

blue materials are needed since the spectrum of the light can only be reduced by the converters but the blue materials are always the less efficient both in terms of light emission and lifetime.

- a third possibility illustrated by figure 3 is to use different OLED emitters for the 3 colours red, green and blue. This type of display requires at least 3 material deposition steps but the emitters are more efficient since not filtered.

[0008] The invention is more particularly adapted to the displays of figure 3. It can be also used for the other types of display but with fewer advantages.

[0009] The use of three different OLED materials (one par colour) implies that they all have different behaviours. This means that they all have different threshold voltages and different efficiencies as illustrated by figure 4. In the example of figure 4, the threshold voltage $V_{B_{th}}$ of the blue material is greater than the threshold voltage $V_{G_{th}}$ of the green material that is itself greater than the threshold voltage $V_{R_{th}}$ of the red material. Moreover, the efficiency of the green material is greater than the efficiencies of the red and blue materials. Consequently, in order to achieve a given colour temperature, the gain between these 3 colours must be further adjusted depending on the material colour coordinates in the space. For instance, the following materials are used:

Red ($x=0.64;y=0.33$) with 6 cd/A and $V_{R_{th}} = 3V$

Green ($x=0.3;y=0.6$) with 20 cd/A and $V_{G_{th}} = 3.3V$

Blue ($x=0.15;y=0.11$) with 4 cd/A and $V_{R_{th}} = 3.5V$

[0010] Thus a white colour temperature of 6400°K ($x=0.313;y=0.328$) is achieved by using 100% of the red, 84% of the green and 95% of the blue.

[0011] If one driver with only one set of reference signals (voltages or currents) for the 3 colours is used and if the maximum voltage to be applied to the cells is 7 Volts ($=V_{max}$), the voltage range must be from 3V to 7V but only a part of this dynamic can be used and all corrections must be done digitally. Such a correction will reduce the video dynamic of the whole display. Figure 5 illustrates the final used video dynamic for the 3 colours. More particularly, the figure 5 shows the range used for each diode (colour material) in order to have proper colour temperature and black level. Indeed, the minimum voltage V_{min} ($=V7$ in the previous table) to be applied to the diodes must be chosen equal to 3V to enable switching OFF the red diode and the lowest lighting voltage ($=V7+(V6-V7)x9/1175$ in the previous table) must be chosen according the blue threshold level to adjust black level. The maximum voltage to be chosen for each diode is adapted to the white colour temperature that means 100% red, 84% green and 95% blue. Finally, it can be seen that only a very small part of the green video range is used.

[0012] Since the video levels between 3V and 7V are defined with 256 bits, it means that the green component is displayed with only a few digital levels. The red component uses a bit more gray level but this is still not enough to provide a satisfying picture quality.

[0013] A solution is disclosed in the European patent application 05292435.4 filed in the name of Deutsche Thomson-Brandt GmbH. In this application, a different reference signalling is used to display each of the three colour components. In this solution, the luminous elements are addressed in a way different from the standard addressing.

[0014] Figure 6 illustrates the standard addressing of video data in an AMOLED display. The matrix of luminous elements comprises for example 320x3=960 columns (320 columns per colour) C0 to C959 and 240 rows L0 to L239 like a QVGA display (320x240 pixels). For the sake of simplicity, only 5 rows L0 to L4 and 5 columns C0 to C3 and C959 are shown in this figure. C0 is a column of red luminous elements, C1 is a column of green luminous elements, C2 is a column of blue luminous elements, C3 is a column of red luminous elements and so on. Each output of the row driver is connected to a row of luminous elements of the matrix. The video data that must be addressed to the luminous element belonging to the column Ci and the row Lj is expressed by $X(i,j)$ wherein X designates one of the colour components R, G, B. The video data of the picture to be displayed are processed by a signal processing unit that delivers the video data $R(0,0)$, $G(1,0)$, $B(2,0)$, $R(3,0)$, $G(4,0)$, $B(5,0)$, ... $R(957,0)$, $G(958,0)$, $B(959,0)$ for the row of luminous elements L0 and the reference voltages to be used for displaying said video data to a data driver (or column driver) having 960 outputs, each output being connected to a column of the matrix. The same set of reference voltages is used for all the video data. Consequently, to display colours, this standard addressing requires an adjustment of the reference voltages com-

bined with a video adjustment of the three colours but these adjustments does not prevent from having a large loss of the video dynamic as shown in Figure 5.

[0015] The solution presented in the above-mentioned European patent application 05292435.4 is a specific addressing that can be used in a standard active matrix OLED. The idea is to have a set of reference voltages (or currents) for each colour and to address three times per frame the luminous elements of the display such that the video frame is divided into three sub-frames, each sub-frame being adapted to display mainly a dedicated colour by using the corresponding set of reference voltages. The main colour to be displayed as and the set of reference voltages change at each sub-frame.

[0016] For example, the red colour is displayed during the first sub-frame with the set of reference voltages dedicated to the red colour, the green colour is displayed during the second sub-frame with the set of reference voltages dedicated to the green colour and the blue colour is displayed during the third sub-frame with the set of reference voltages dedicated to the blue colour.

[0017] A little bit different solution is explained in more detail in reference to figure 7 that illustrates a possible embodiment. During the first sub-frame, the three components are displayed using the reference voltages adapted to the green component to dispose of a full grayscale dynamic for this component. {V0(G), V1(G), V2(G), V3(G), V4(G), V5(G), V6(G), V7(G)} designates the set of reference voltages dedicated to the green component. The two other components are only partially displayed. So the sub-picture displayed during this sub-frame is greenish/yellowish. During the second sub-frame, the green component is deactivated (set to zero) and the voltages are adapted to dispose of a full dynamic for the red component by using the set of reference voltages dedicated to the red component {V0(R), V1(R), V2(R), V3(R), V4(R), V5(R), V6(R), V7(R)}. The sub-picture displayed during this sub-frame is purplish. Finally during the third sub-frame, the green and red components are deactivated (set to zero) and the voltages are adapted to dispose of a full dynamic for the blue component by using the set of reference voltages dedicated to the blue component {V0(B), V1(B), V2(B), V3(B), V4(B), V5(B), V6(B), V7(B)}.

[0018] It is thus possible to adjust the 8 reference voltages (or currents) at each sub-frame. The only particularity is that the lowest reference voltages must be kept equal to the lowest threshold voltage of the three colours. Indeed, displaying a blue component means having red and green components equal to zero, which means equal to V7 that is the lowest reference voltage. So, this voltage must be low enough to have them really black. In the example of Figure 5, we must have

$$V7(R) = V7(B) = V7(G) = VR_{th}$$

[0019] The only additional requirement is the necessity of addressing the matrix three times faster.

[0020] Figures 8 to 10 illustrates the functioning of the display device during the three sub-frames. In reference to figure 8, during the first sub-frame, the video data of the picture to be displayed are converted into voltages to be applied to the luminous elements of the matrix by the data driver that uses the set of reference voltages dedicated to the green component. The set of reference voltages are distributed between 3 volts (=V7(G)=VR_{th}) and about 4 volts =V0(G) that is the maximum voltage that can be used for displaying the green component.

An example of reference voltages for the green component is given below:

Reference V _n	Voltage (Volts)
V0	4
V1	3.85
V2	3.75
V3	3.45
V4	3.2
V5	3.1
V6	3.05
V7	3

[0021] In reference to figure 9, during the second sub-frame, the video data of the picture to be displayed are converted into voltages to be applied to the luminous elements of the matrix by the data driver that uses the set of reference voltages

EP 1 873 744 A1

dedicated to the red component. The video data corresponding to the green and red components are set to zero. The set of reference voltages are distributed between 3 volts ($=V7(R)=VR_{th}$) and about 5,4 volts $=V0(R)$ that is the maximum voltage that can be used for displaying the red component.

An example of reference voltages for the red component is given below:

5

Reference V_n	Voltage (Volts)
V0	5.4
V1	5.08
V2	4.76
V3	4.12
V4	3.48
V5	3.24
V6	3.13
V7	3

10

15

20

[0022] In reference to figure 10, during the third sub-frame, the video data of the picture to be displayed are converted into voltages to be applied to the luminous elements of the matrix by the data driver that uses the set of reference voltages dedicated to the blue component. The video data corresponding to the green component are set to zero. The set of reference voltages are distributed between 3 volts ($=V7(G)=VR_{th}$) and about 7 volts $=V0(B)$ that is the maximum voltage that can be used for displaying the blue component.

25

[0023] An example of reference voltages for the blue component is given below:

30

Reference V_n	Voltage (Volts)
V0	7
V1	6.46
V2	5.93
V3	4.86
V4	3.8
V5	3.4
V6	3.21
V7	3

35

40

[0024] In a more general manner, the colour component having the highest luminosity capabilities (in the present case, the green component) is displayed only in the first sub-frame. The colour component having the lowest luminosity capabilities (in the present case, the blue component) is displayed in the three sub-frames and the colour component having in-between luminosity capabilities (in the present case, the red component) is displayed during two sub-frames.

45

[0025] A drawback of this solution is that it requires addressing the matrix three times faster than a standard addressing. Another drawback is that there is some colour lag on moving edges since different colours are displayed at different time periods (for example Red+Green+Blue during the first sub-frame, Red+Blue during the second sub-frame and .only blue during the third sub-frame)

50

Invention

[0026] It is an object of the present invention to propose a solution to reduce one or more of these drawbacks. According to the invention, new AMOLED matrix structures are proposed and these new structures can be used to have different sets of reference voltages (or currents) for different colour components.

55

[0027] This object is solved by a display device comprising

- an active matrix containing an array of luminous elements arranged in n rows and m columns, each luminous element

being associated to a colour component among k different colour components of a picture to be displayed, k being greater than 1 and the luminous elements being arranged in groups of k consecutive luminous elements associated to different colour components,

- a first driver having p outputs connected to the active matrix for selecting luminous elements of the matrix; each output of the first driver being connected to a different part of the matrix and the parts of the matrix being selected by the first driver one after the other,
- a second driver having q outputs connected to the active matrix for delivering a signal to each luminous element selected by the first driver, said signal depending on the video information to be displayed by the selected luminous elements; and
- a digital processing unit for delivering video information to the second driver and control signals to the first driver.

[0028] According to the invention, each output of the first driver is connected to luminous elements associated to a same colour component, the signal of the video information to be displayed by each of the luminous elements connected to an output of the first driver being delivered by a separate output of the second driver.

[0029] Thus, as the different parts of the matrix are selected one after the other and as each part of the matrix is associated to a same colour component (all the luminous elements of a part of the matrix are connected to the same output of the first driver), a set of reference voltages (or currents) associated to this colour component can be selected when said part of matrix is selected.

[0030] Several embodiments are possible depending on whether the k luminous elements of each group belong to one and the same row or to one and the same column of luminous elements of the matrix. Several embodiments are also possible depending on the number of outputs of the first and second driver.

[0031] In a first embodiment, the k luminous elements of each group belong to one and the same row, the first driver has $p=n$ outputs, the second driver has $q=m$ outputs and each output of the first driver is connected to all luminous elements associated to a same colour component and belonging to k rows of luminous elements of the active matrix.

[0032] In a second embodiment, the k luminous elements of each group belong to one and the same row, the first driver has $p=k*n$ outputs, the second driver has $q=m/k$ outputs and each output of the first driver is connected to all luminous elements associated to a same colour component and belonging to a same row of luminous elements of the matrix. Each output of the second driver is connected to the k luminous elements of a same group of luminous elements. In this embodiment, two consecutive outputs of the first driver are connected to luminous elements associated to different colour components.

[0033] In a third embodiment which is a variant of the second embodiment, at least two consecutive outputs of the first driver are connected to luminous elements associated to a same colour component.

[0034] In a fourth embodiment, the k luminous elements of each group belong to one and the same column of luminous elements of the active matrix, the first driver has $p=n/k$ outputs and the second driver has $q=m*k$ outputs. k outputs of the second driver are connected to luminous elements of a same column, each one of said k outputs being connected to luminous elements associated to a same colour component and each output of the first driver is connected to all luminous elements associated to a same colour component and belonging to a same column of luminous elements and to k rows of luminous elements of the active matrix.

[0035] In all these embodiments, the video information delivered to the second driver is based on sets of reference signals, a different set of reference signals being associated to at least two different colour components. The digital processing unit controls the first driver and delivers video information and reference signals to the second driver such that, each time the luminous elements connected to an output of the first driver are selected, the digital processing unit delivers to the second driver the video information of the luminous elements selected by the first driver and the set of reference signals associated to the colour component of these selected luminous elements.

Brief description of the drawings

[0036] Exemplary embodiments of the invention are illustrated in the drawings and are explained in more detail in the following description. In the drawings:

- Fig.1 shows a white OLED emitter having 3 colour filters for generating the red, green and blue colours;
- Fig.2 shows a blue OLED emitter having 2 colour converters for generating the red, green and blue colours;
- Fig.3 shows a red OLED emitter, a green OLED emitter and a blue OLED emitter for generating the red, green and blue colours;
- Fig.4 is a schematic diagram illustrating the threshold voltages and the efficiencies of blue, green and red OLED materials;
- Fig.5 shows the video range used for each blue, green and red OLED material of figure 4;
- Fig.6 illustrates the standard addressing of video data in an AMOLED display;

- Fig.7 illustrates the addressing of video data in an AMOLED display in prior art;
- Fig.8 illustrates the addressing of video data in an AMOLED display during a first sub-frame of the video frame in accordance with Fig.7;
- 5 Fig.9 illustrates the addressing of video data in an AMOLED display during a second sub-frame of the video frame in accordance with Fig.7;
- Fig.10 illustrates the addressing of video data in an AMOLED display during a third sub-frame of the video frame in accordance with Fig.7;
- Fig.11 illustrates the connection of the first driver (row driver) and the second driver (data driver) to the active matrix according to the invention;
- 10 Fig.12 shows a layout for a part of 3x3 luminous elements of the active matrix;
- Fig.13 illustrates the addressing of video data in the display device of figure 11 when the output L0 of the first driver is activated;
- Fig.14 illustrates the addressing of video data in the display device of figure 11 when the output L1 of the first driver is activated;
- 15 Fig.15 illustrates the addressing of video data in the display device of figure 11 when the output L2 of the first driver is activated;
- Fig.16 illustrates the addressing of video data in the display device of figure 11 when the output L3 of the first driver is activated;
- Fig.17 shows a layout for 4 parts of 3x3 luminous elements of the active matrix;
- 20 Fig.18 illustrates a first variant of figure 11;
- Fig.19 illustrates a second variant of figure 11; and
- Fig.20 illustrates a third variant of figure 11.

DESCRIPTION OF PREFERRED EMBODIMENTS

25 **[0037]** The idea of the invention is to address at one given time period of the video frame only the luminous elements associated to one colour component by amending the connection of the row driver and the column driver to the active matrix and by addressing differently the video information to the column driver. In the following specification, the row driver is called first driver because a same output of this driver can select luminous elements belonging to a group of

30 rows and the column driver is called second driver because two outputs of this driver can deliver simultaneously video information to luminous elements belonging to a same column of the matrix. The internal structure of the first and second drivers is identical to the one of classical row and column drivers and is well known from the man skilled in the art.

[0038] Figure 11 shows a display device comprising a QVGA matrix 10 of luminous elements arranged in 240 rows and 320x3 columns, a first driver 20 comprising 240 outputs L0 to L239 for selecting luminous elements of the matrix,

35 a second driver 30 comprising 960 (=320x3) outputs C0 to C959 connected to the luminous elements of the matrix and a video processing unit 40 for delivering video information and a set of reference voltages to the second driver. The first column of the matrix comprises only red luminous elements, the second column comprises only green luminous elements, the third column comprises only blue luminous elements, the fourth column comprises only red luminous elements and so on. A first way of connecting the outputs L0 to L239 of the driver 20 and the outputs C0 to C959 of the driver 30 to the luminous elements of the matrix 10 is illustrated by Figure 11. The connection of a luminous element to an output

40 Ci of the second driver and an output Lj of the first driver is shown by a black point placed at the intersection of a column line connected to the output Ci and a row line connected to the output Lj. For example, the driver outputs C0 and L0 are connected to the first luminous element of the first row of the matrix, the driver outputs C1 and L1 are connected to the second luminous element of the first row of the matrix and the driver outputs C2 and L2 are connected to the third

45 luminous element of the first row of the matrix. In this figure, 3 row lines are connected to each output Lj of the driver 20 and 3 column lines are connected to each output Ci of the driver 30 and all these lines are rectilinear and go throughout the matrix of cells.

[0039] Figure 12 shows in more detail an example for connecting the driver outputs L0 to L2 and C0 to C2 to the first 3x3 luminous elements of the matrix. In this figure, each luminous element comprises an arrangement of two transistors

50 T1 and T2, a capacitor and an organic light emitting diode (OLED). This arrangement is well known from the man skilled in the art. In a more general way, the driver output L0 is connected to all the red luminous elements of the three first rows of the matrix, the driver output L1 is connected to all the green luminous elements of the three first rows of the matrix and the driver output L2 is connected to all the blue luminous elements of the three first rows of the matrix. A separate output of the driver 30 is connected to each red luminous element of the three first rows of the matrix. The

55 output C0 is connected to the first red luminous element of the first row of the matrix, the output C1 is connected to the first red luminous element of the second row of the matrix and the output C2 is connected to the first red luminous element of the third row of the matrix. For the green component, the output C1 is connected to the first green luminous element of the first row of the matrix, the output C2 is connected to the first green luminous element of the second row

of the matrix and the output C0 is connected to the first green luminous element of the third row of the matrix. For the blue component, the output C2 is connected to the first blue luminous element of the first row of the matrix, the output C0 is connected to the first blue luminous element of the second row of the matrix and the output C1 is connected to the first blue luminous element of the third row of the matrix.

5 **[0040]** Figures 13 to 16 illustrate the functioning of the display device according to the invention. When displaying a picture, the driver 20 activates sequentially its outputs Lj. Figure 13 shows the video information sent to the second driver 30 when the outputs L0 of the driver 20 is activated (ON). The red luminous elements of the three first rows (rows numbered 0, 1 and 2) of the matrix are thus selected. The video information R(0,0), R(0,1) R(0,2), R(3,0), R(3,1) R(3,2)...R(957,2) is sent to the driver 30. R(i,j) designates the piece of video information dedicated to the red luminous element belonging to the column i and the row j of the matrix. As only red luminous elements are selected when the output L0 is activated, the set of voltage references dedicated to the red component {V0(R), V1(R), V2(R), V3(R), V4(R), V5(R), V6(R), V7(R)} is sent also to the second driver 30. The video information is converted into voltages by the driver 30 and these voltages are applied to the selected luminous elements. The graph at the bottom-right corner of figure 13 shows the used diode dynamic when the output L0 is selected and when the set of reference voltages are distributed between 3 volts (=V7(R)=VR_{th}) and about 5,4 volts =V0(R) that is the maximum voltage that can be used for displaying the red component. The example of reference voltages given above in a table for the red component can be used.

10 **[0041]** Figure 14 shows the video information sent to the second driver 30 when the outputs L1 of the driver 20 is activated (ON). The green luminous elements of the three first rows of the matrix are thus selected. The video information G(1,0), G(1,1) G(1,2), G(4,0), G(4,1) G(4,2)...G(958,2) is sent to the driver 30. G(i,j) designates the piece of video information dedicated to the green luminous element belonging to the column i and the row j of the matrix. As only green luminous elements are selected when the output L1 is activated, the set of voltage references dedicated to the green component {V0(G), V1(G), V2(G), V3(G), V4(G), V5(G), V6(G), V7(G)} is sent also to the second driver 30. The video information is converted into voltages by the driver 30 and these voltages are applied to the selected luminous elements. The graph at the bottom-right corner of figure 14 shows the used diode dynamic when the output L1 is selected and when the set of reference voltages are distributed between 3 volts (=V7(G)=VR_{th}) and about 4 volts =V0(G) that is the maximum voltage that can be used for displaying the green component. The example of reference voltages given above in a table for the green component can be used.

15 **[0042]** Figure 15 shows the video information sent to the second driver 30 when the outputs L2 of the driver 20 is activated (ON). The blue luminous elements of the three first rows of the matrix are thus selected. The video information B(2,0), B(2,1) B(2,2), B(5,0), B(5,1) B(5,2)...B(959,2) is sent to the driver 30. B(i,j) designates the piece of video information dedicated to the blue luminous element belonging to the column i and the row j of the matrix. As only blue luminous elements are selected when the output L2 is activated, the set of voltage references dedicated to the blue component {V0(B), V1(B), V2(B), V3(B), V4(B), V5(B), V6(B), V7(B)} is sent also to the second driver 30. The video information is converted into voltages by the driver 30 and these voltages are applied to the selected luminous elements. The graph at the bottom-right corner of figure 15 shows the used diode dynamic when the output L2 is selected and when the set of reference voltages are distributed between 3 volts (=V7(B)=VR_{th}) and about 7 volts =V0(B) that is the maximum voltage that can be used for displaying the green component. The example of reference voltages given above in a table for the blue component can be used.

20 **[0043]** Figure 16 shows the video information sent to the second driver 30 when the outputs L3 of the driver 20 is activated (ON). The red luminous elements of the fourth, fifth and sixth rows (rows numbered 3, 4 and 5) of the matrix are thus selected. The video information R(0,3), R(0,4) R(0,5), R(3,3), R(3,4) R(3,5)...R(957,5) is sent to the driver 30. As previously mentioned, R(i,j) designates the piece of video information dedicated to the red luminous element belonging to the column i and the row j of the matrix. As only red luminous elements are selected when the output L3 is activated, the set of voltage references dedicated to the red component {V0(R), V1(R), V2(R), V3(R), V4(R), V5(R), V6(R), V7(R)} is sent also to the second driver 30. The video information is converted into voltages by the driver 30 and these voltages are applied to the selected luminous elements. The graph at the bottom-right corner of figure 16 shows the used diode dynamic when the output L3 is selected and when the set of reference voltages are distributed between 3 volts (=V7(R)=VR_{th}) and about 5,4 volts = V0(G).

25 **[0044]** The final matrix of the display device is based on a cyclical repetition of the basic 3x3 matrix presented Figure 12 as illustrated by Figure 17.

30 **[0045]** Generally speaking, a standard driver usage is kept according the invention. The outputs Lj of the driver 20 are activated sequentially and, at each time an output Lj is activated, video information are delivered on all outputs Ci of the driver 30.

35 **[0046]** On the other hand, Figure 12 shows that there is a complex networking required to have the proper signal dedicated to the proper luminous element. In any case, there is no need of fast addressing as in the solution presented in the preamble of the present specification. A video data rearrangement is just needed in the signal processing unit 40. A permutation between the video data inside each 3x3 matrix is needed. This permutation can be the following one for a QVGA (320x3 columns and 240 rows of luminous elements):

$\text{Data}(3i;3j) \Rightarrow \text{Data}(3i;3j)$ (unchanged)

5

$\text{Data}(3i+1;3j) \Rightarrow \text{Data}(3i;3j+1)$

10

$\text{Data}(3i+2;3j) \Rightarrow \text{Data}(3i;3j+2)$

15

$\text{Data}(3i;3j+1) \Rightarrow \text{Data}(3i+1;3j)$

$\text{Data}(3i+1;3j+1) \Rightarrow \text{Data}(3i+1;3j+1)$ (unchanged)

20

$\text{Data}(3i+2;3j+1) \Rightarrow \text{Data}(3i+1;3j+2)$

25

$\text{Data}(3i;3j+2) \Rightarrow \text{Data}(3i+2;3j)$

30

$\text{Data}(3i+1;3j+2) \Rightarrow \text{Data}(3i+2;3j+1)$

$\text{Data}(3i+2;3j+2) \Rightarrow \text{Data}(3i+2;3j+2)$ (unchanged)

35

where Data (i,j) designates the data to be displayed by the luminous elements belonging to column i and row j of the matrix.

[0047] In summary, each output L_j activates the same colour component on three consecutive rows of the matrix. Then, the reference voltages (currents) are adjusted to the video information addressing so that each time a new output L_j is activated the corresponding reference voltages (currents) are transmitted to the driver 30.

40 **[0048]** To reduce the cost of the display device, this matrix organization can be combined with a different second

driver (data driver) that is less expensive. Indeed, the data drivers are the most expensive components whereas the row drivers are simpler and can be even integrated directly on the TFT-backplane (TFT = Thin Film Transistor) of the matrix.

Figure 18 illustrates a display device where the second driver 30 comprises only 320 outputs (instead of 3x320 outputs) and the first driver 20 comprises 240x3 outputs (instead of 240 outputs). The driver 20 comprises three times more

45 outputs than previously but the driver 30 comprises three times less outputs than previously. The cost of the display device is reduced because the cost of the driver 30 is reduced. In this embodiment, 720 rows are sequentially addressed

instead of 240 rows. The red luminous elements of the row j of the matrix are connected to the output LR_j of the driver 20. The green luminous elements of the row j of the matrix are connected to the output LG_j of the driver 20. The blue

luminous elements of the row j of the matrix are connected to the output LB_j of the driver 20. A same column output C_i

50 is connected to three consecutive luminous elements connected to three different row outputs. In this embodiment, the

flow of video information is rearranged differently.

55

$\text{Data}(3i;j) \Rightarrow \text{Data}(i;j)$

$$\text{Data}(3i+1;j) \Rightarrow \text{Data}(319+i;j)$$

5

$$\text{Data}(3i+2;j) \Rightarrow \text{Data}(639+i;j)$$

[0049] In this embodiment, two consecutive outputs of the driver 20 are always connected to luminous elements associated to different colour components. For example, the output LR1 is consecutive to the output LB0 and LR1 is connected to red luminous elements while LB0 is connected to blue luminous elements.

[0050] In a variant illustrated by Figure 19, two consecutive outputs of the driver 20 are not always connected to luminous elements associated to different colour components. For example, the output LB1 is consecutive to the output LB0 and are both connected to blue luminous elements. In this embodiment, the flow of video information is rearranged differently.

15

- for rows numbered $j \bmod 6$, $j+1 \bmod 6$ and $j+2 \bmod 6$, $\forall j \in \mathbb{N}$

20

$$\text{Data}(3i;j) \Rightarrow \text{Data}(i;j)$$

25

$$\text{Data}(3i+1;j) \Rightarrow \text{Data}(319+i;j)$$

30

$$\text{Data}(3i+2;j) \Rightarrow \text{Data}(639+i;j)$$

- for rows numbered $j+3 \bmod 6$, $j+4 \bmod 6$ and $j+5 \bmod 6$, $\forall j \in \mathbb{N}$

35

$$\text{Data}(3i;j) \Rightarrow \text{Data}(639+i;j)$$

40

$$\text{Data}(3i+1;j) \Rightarrow \text{Data}(319+i;j)$$

$$\text{Data}(3i+2;j) \Rightarrow \text{Data}(i;j)$$

[0051] These two embodiments (figures 18 and 19) have a reduced cost but require a higher addressing speed (3 times faster) since three times more rows must be addressed per frame.

45

[0052] This matrix organization presented in the above-mentioned embodiments with a Red, Green, Blue standard alignment (all colour components on the same row of the matrix) requires a complex active matrix networking. A simplification of the layout of the active matrix can be obtained by using a vertical colour adjustment as illustrated by Figure 20. In this figure, the luminous elements of the matrix are arranged into 240x3 rows and 320 columns. All colour components (red, green, blue) are represented on a same column of the matrix. In this figure, the second driver 30 comprises 320x3=960 outputs and the first driver 20 comprises 240/3=80 outputs. The red luminous elements of a group of nine consecutive rows of the matrix are connected to the output L_j of the driver 20. The green luminous elements of this group of nine consecutive rows are connected to the output L_{j+1} of the driver 20 and the blue luminous elements of the group of nine consecutive rows are connected to the output L_{j+2} of the driver 20. A same column output C_i is connected to three luminous elements of said group of rows, each one of these luminous elements being connected to a different row output L_j . In this embodiment, the flow of video information is also rearranged.

50

55

[0053] The invention is not restricted to the disclosed embodiments. Various modifications are possible and are considered to fall within the scope of the claims, e.g. other OLED materials with other threshold voltages and efficiencies

EP 1 873 744 A1

can be used;...

ANNEX 1

5

10

15

20

25

30

35

40

45

50

55

Level	Voltage		
		33	$V5+(V4-V5) \times 119/1501$
0	V7	34	$V5+(V4-V5) \times 176/1501$
1	$V7+(V6-V7) \times 9/1175$	35	$V5+(V4-V5) \times 231/1501$
2	$V7+(V6-V7) \times 32/1175$	36	$V5+(V4-V5) \times 284/1501$
3	$V7+(V6-V7) \times 76/1175$	37	$V5+(V4-V5) \times 335/1501$
4	$V7+(V6-V7) \times 141/1175$	38	$V5+(V4-V5) \times 385/1501$
5	$V7+(V6-V7) \times 224/1175$	39	$V5+(V4-V5) \times 434/1501$
6	$V7+(V6-V7) \times 321/1175$	40	$V5+(V4-V5) \times 483/1501$
7	$V7+(V6-V7) \times 425/1175$	41	$V5+(V4-V5) \times 532/1501$
8	$V7+(V6-V7) \times 529/1175$	42	$V5+(V4-V5) \times 580/1501$
9	$V7+(V6-V7) \times 630/1175$	43	$V5+(V4-V5) \times 628/1501$
10	$V7+(V6-V7) \times 727/1175$	44	$V5+(V4-V5) \times 676/1501$
11	$V7+(V6-V7) \times 820/1175$	45	$V5+(V4-V5) \times 724/1501$
12	$V7+(V6-V7) \times 910/1175$	46	$V5+(V4-V5) \times 772/1501$
13	$V7+(V6-V7) \times 998/1175$	47	$V5+(V4-V5) \times 819/1501$
14	$V7+(V6-V7) \times 1086/1175$	48	$V5+(V4-V5) \times 866/1501$
15	V6	49	$V5+(V4-V5) \times 912/1501$
16	$V6+(V5-V6) \times 89/1097$	50	$V5+(V4-V5) \times 957/1501$
17	$V6+(V5-V6) \times 173/1097$	51	$V5+(V4-V5) \times 1001/1501$
18	$V6+(V5-V6) \times 250/1097$	52	$V5+(V4-V5) \times 1045/1501$
19	$V6+(V5-V6) \times 320/1097$	53	$V5+(V4-V5) \times 1088/1501$
20	$V6+(V5-V6) \times 386/1097$	54	$V5+(V4-V5) \times 1131/1501$
21	$V6+(V5-V6) \times 451/1097$	55	$V5+(V4-V5) \times 1173/1501$
22	$V6+(V5-V6) \times 517/1097$	56	$V5+(V4-V5) \times 1215/1501$
23	$V6+(V5-V6) \times 585/1097$	57	$V5+(V4-V5) \times 1257/1501$
24	$V6+(V5-V6) \times 654/1097$	58	$V5+(V4-V5) \times 1298/1501$
25	$V6+(V5-V6) \times 723/1097$	59	$V5+(V4-V5) \times 1339/1501$
26	$V6+(V5-V6) \times 790/1097$	60	$V5+(V4-V5) \times 1380/1501$
27	$V6+(V5-V6) \times 855/1097$	61	$V5+(V4-V5) \times 1421/1501$
28	$V6+(V5-V6) \times 917/1097$	62	$V5+(V4-V5) \times 1461/1501$
29	$V6+(V5-V6) \times 977/1097$	63	V4
30	$V6+(V5-V6) \times 1037/1097$	64	$V4+(V3-V4) \times 40/2215$
31	V5	65	$V4+(V3-V4) \times 80/2215$
32	$V5+(V4-V5) \times 60/1501$	66	$V4+(V3-V4) \times 120/2215$
67	$V4+(V3-V4) \times 160/2215$	103	$V4+(V3-V4) \times 1495/2215$
68	$V4+(V3-V4) \times 200/2215$	104	$V4+(V3-V4) \times 1528/2215$
69	$V4+(V3-V4) \times 240/2215$	105	$V4+(V3-V4) \times 1561/2215$
70	$V4+(V3-V4) \times 280/2215$	106	$V4+(V3-V4) \times 1593/2215$

EP 1 873 744 A1

(continued)

Level	Voltage			
			33	V5+(V4-V5)x119/1501
	71	V4+(V3-V4)x320/2215	107	V4+(V3-V4)x1625/2215
5	72	V4+(V3-V4)x360/2215	108	V4+(V3-V4)x1657/2215
	73	V4+(V3-V4)x400/2215	109	V4+(V3-V4)x1688/2215
	74	V4+(V3-V4)x440/2215	110	V4+(V3-V4)x1719/2215
10	75	V4+(V3-V4)x480/2215	111	V4+(V3-V4)x1750/2215
	76	V4+(V3-V4)x520/2215	112	V4+(V3-V4)x1781/2215
	77	V4+(V3-V4)x560/2215	113	V4+(V3-V4)x1811/2215
15	78	V4+(V3-V4)x600/2215	114	V4+(V3-V4)x1841/2215
	79	V4+(V3-V4)x640/2215	115	V4+(V3-V4)x1871/2215
	80	V4+(V3-V4)x680/2215	116	V4+(V3-V4)x1901/2215
	81	V4+(V3-V4)x719/2215	117	V4+(V3-V4)x1930/2215
20	82	V4+(V3-V4)x758/2215	118	V4+(V3-V4)x1959/2215
	83	V4+(V3-V4)x796/2215	119	V4+(V3-V4)x1988/2215
	84	V4+(V3-V4)x834/2215	120	V4+(V3-V4)x2016/2215
25	85	V4+(V3-V4)x871/2215	121	V4+(V3-V4)x2044/2215
	86	V4+(V3-V4)x908/2215	122	V4+(V3-V4)x2072/2215
	87	V4+(V3-V4)x944/2215	123	V4+(V3-V4)x2100/2215
	88	V4+(V3-V4)x980/2215	124	V4+(V3-V4)x2128/2215
30	89	V4+(V3-V4)x1016/2215	125	V4+(V3-V4)x2156/2215
	90	V4+(V3-V4)x1052/2215	126	V4+(V3-V4)x2185/2215
	91	V4+(V3-V4)x1087/2215	127	V3
35	92	V4+(V3-V4)x1122/2215	128	V3+(V2-V3)x31/2343
	93	V4+(V3-V4)x1157/2215	129	V3+(V2-V3)x64/2343
	94	V4+(V3-V4)x1192/2215	130	V3+(V2-V3)x97/2343
	95	V4+(V3-V4)x1226/2215	131	V3+(V2-V3)x130/2343
40	96	V4+(V3-V4)x1260/2215	132	V3+(V2-V3)x163/2343
	97	V4+(V3-V4)x1294/2215	133	V3+(V2-V3)x196/2343
	98	V4+(V3-V4)x1328/2215	134	V3+(V2-V3)x229/2343
45	99	V4+(V3-V4)x1362/2215	135	V3+(V2-V3)x262/2343
	100	V4+(V3-V4)x1396/2215	136	V3+(V2-V3)x295/2343
	101	V4+(V3-V4)x1429/2215	137	V3+(V2-V3)x328/2343
	102	V4+(V3-V4)x1462/2215	138	V3+(V2-V3)x361/2343
50	139	V3+(V2-V3)x395/2343	175	V3+(V2-V3)x1712/2343
	140	V3+(V2-V3)x429/2343	176	V3+(V2-V3)x1751/2343
	141	V3+(V2-V3)x463/2343	177	V3+(V2-V3)x1790/2343
55	142	V3+(V2-V3)x497/2343	178	V3+(V2-V3)x1829/2343
	143	V3+(V2-V3)x531/2343	179	V3+(V2-V3)x1868/2343
	144	V3+(V2-V3)x566/2343	180	V3+(V2-V3)x1907/2343

EP 1 873 744 A1

(continued)

Level	Voltage			
			33	$V5+(V4-V5) \times 119/1501$
	145	$V3+(V2-V3) \times 601/2343$	181	$V3+(V2-V3) \times 1946/2343$
5	146	$V3+(V2-V3) \times 636/2343$	182	$V3+(V2-V3) \times 1985/2343$
	147	$V3+(V2-V3) \times 671/2343$	183	$V3+(V2-V3) \times 2024/2343$
	148	$V3+(V2-V3) \times 706/2343$	184	$V3+(V2-V3) \times 2064/2343$
10	149	$V3+(V2-V3) \times 741/2343$	185	$V3+(V2-V3) \times 2103/2343$
	150	$V3+(V2-V3) \times 777/2343$	186	$V3+(V2-V3) \times 2143/2343$
	151	$V3+(V2-V3) \times 813/2343$	187	$V3+(V2-V3) \times 2183/2343$
15	152	$V3+(V2-V3) \times 849/2343$	188	$V3+(V2-V3) \times 2223/2343$
	153	$V3+(V2-V3) \times 885/2343$	189	$V3+(V2-V3) \times 2263/2343$
	154	$V3+(V2-V3) \times 921/2343$	190	$V3+(V2-V3) \times 2303/2343$
	155	$V3+(V2-V3) \times 958/2343$	191	V2
20	156	$V3+(V2-V3) \times 995/2343$	192	$V2+(V1-V2) \times 40/1638$
	157	$V3+(V2-V3) \times 1032/2343$	193	$V2+(V1-V2) \times 81/1638$
	158	$V3+(V2-V3) \times 1069/2343$	194	$V2+(V1-V2) \times 124/1638$
25	159	$V3+(V2-V3) \times 1106/2343$	195	$V2+(V1-V2) \times 168/1638$
	160	$V3+(V2-V3) \times 1143/2343$	196	$V2+(V1-V2) \times 213/1638$
	161	$V3+(V2-V3) \times 1180/2343$	197	$V2+(V1-V2) \times 259/1638$
	162	$V3+(V2-V3) \times 1217/2343$	198	$V2+(V1-V2) \times 306/1638$
30	163	$V3+(V2-V3) \times 1255/2343$	199	$V2+(V1-V2) \times 353/1638$
	164	$V3+(V2-V3) \times 1293/2343$	200	$V2+(V1-V2) \times 401/1638$
	165	$V3+(V2-V3) \times 1331/2343$	201	$V2+(V1-V2) \times 450/1638$
35	166	$V3+(V2-V3) \times 1369/2343$	202	$V2+(V1-V2) \times 499/1638$
	167	$V3+(V2-V3) \times 1407/2343$	203	$V2+(V1-V2) \times 548/1638$
	168	$V3+(V2-V3) \times 1445/2343$	204	$V2+(V1-V2) \times 597/1638$
	169	$V3+(V2-V3) \times 1483/2343$	205	$V2+(V1-V2) \times 646/1638$
40	170	$V3+(V2-V3) \times 1521/2343$	206	$V2+(V1-V2) \times 695/1638$
	171	$V3+(V2-V3) \times 1559/2343$	207	$V2+(V1-V2) \times 745/1638$
	172	$V3+(V2-V3) \times 1597/2343$	208	$V2+(V1-V2) \times 795/1638$
45	173	$V3+(V2-V3) \times 1635/2343$	209	$V2+(V1-V2) \times 846/1638$
	174	$V3+(V2-V3) \times 1673/2343$	210	$V2+(V1-V2) \times 897/1638$
	211	$V2+(V1-V2) \times 949/1638$	246	$V1+(V0-V1) \times 1794/3029$
	212	$V2+(V1-V2) \times 1002/1638$	247	$V1+(V0-V1) \times 1907/30$
50	213	$V2+(V1-V2) \times 1056/1638$	248	$V1+(V0-V1) \times 2026/3029$
	214	$V2+(V1-V2) \times 1111/1638$	249	$V1+(V0-V1) \times 2150/3029$
	215	$V2+(V1-V2) \times 1167/1638$	250	$V1+(V0-V1) \times 2278/3029$
55	216	$V2+(V1-V2) \times 1224/1638$	251	$V1+(V0-V1) \times 2411/3029$
	217	$V2+(V1-V2) \times 1281/1638$	252	$V1+(V0-V1) \times 2549/3029$
	218	$V2+(V1-V2) \times 1339/1638$	253	$V1+(V0-V1) \times 2694/3029$

(continued)

5

10

15

20

25

30

35

40

Level	Voltage		33	$V5+(V4-V5) \times 119/1501$
219	$V2+(V1-V2) \times 1398/1638$		254	$V1+(V0-V1) \times 2851/3029$
220	$V2+(V1-V2) \times 1458/1638$		255	V0
221	$V2+(V1-V2) \times 1518/1638$			
222	$V2+(V1-V2) \times 1578/1638$			
223	V1			
224	$V1+(V0-V1) \times 60/3029$			
225	$V1+(V0-V1) \times 120/3029$			
226	$V1+(V0-V1) \times 180/3029$			
227	$V1+(V0-V1) \times 241/3029$			
228	$V1+(V0-V1) \times 304/3029$			
229	$V1+(V0-V1) \times 369/3029$			
230	$V1+(V0-V1) \times 437/3029$			
231	$V1+(V0-V1) \times 507/3029$			
232	$V1+(V0-V1) \times 580/3029$			
233	$V1+(V0-V1) \times 655/3029$			
234	$V1+(V0-V1) \times 732/3029$			
235	$V1+(V0-V1) \times 810/3029$			
236	$V1+(V0-V1) \times 889/3029$			
237	$V1+(V0-V1) \times 969/3029$			
238	$V1+(V0-V1) \times 1050/3029$			
239	$V1+(V0-V1) \times 1133/3029$			
240	$V1+(V0-V1) \times 1218/3029$			
241	$V1+(V0-V1) \times 1304/3029$			
242	$V1+(V0-V1) \times 1393/3029$			
243	$V1+(V0-V1) \times 1486/3029$			
244	$V1+(V0-V1) \times 1583/3029$			
245	$V1+(V0-V1) \times 1686/3029$			

Claims

45

1. Display device comprising

50

- an active matrix (10) containing an array of luminous elements arranged in n rows and m columns, each luminous element being associated to a colour component among k different colour components of a picture to be displayed, k being greater than 1 and the luminous elements being arranged in groups of k consecutive luminous elements associated to different colour components,
- a first driver (20) having p outputs (Lj) connected to the active matrix for selecting luminous elements of the matrix, each output of the first driver being connected to a different part of the matrix and the parts of the matrix being selected by the first driver one after the other,
- a second driver (30) having q outputs (Ci) connected to the active matrix for delivering a signal to each luminous element selected by the first driver, said signal depending on the video information to be displayed by the selected luminous elements; and

55

- a digital processing unit (40) for delivering video information to the second driver and control signals to the first driver.

characterized in that each output of the first driver (20) is connected to luminous elements associated to a same colour component, the signal of the video information to be displayed by each of the luminous elements connected to an output of the first driver being delivered by a separate output of the second driver (30).

2. Display device according to claim 1, wherein the k luminous elements of each group belong to one and the same row of luminous elements of the matrix.

3. Display device according to claim 2, wherein the first driver (20) has $p=n$ outputs and the second driver (30) has $q=m$ outputs.

4. Display device according to claim 3, wherein each output of the first driver (20) is connected to all luminous elements associated to a same colour component and belonging to k rows of luminous elements of the active matrix (10).

5. Display device according to claim 2, wherein the first driver (20) has $p=k*n$ outputs and the second driver (30) has $q=m/k$ outputs.

6. Display device according to claim 5, wherein each output of the first driver (20) is connected to all luminous elements associated to a same colour component and belonging to a same row of luminous elements of the matrix and each output of the second driver (30) is connected to the k luminous elements of a same group of luminous elements.

7. Display device according to claim 5 or 6, wherein two consecutive outputs of the first driver (20) are connected to luminous elements associated to different colour components.

8. Display device according to claim 5 or 6, wherein at least two consecutive outputs of the first driver (20) are connected to luminous elements associated to a same colour component.

9. Display device according to claim 1, wherein the k luminous elements of each group belong to one and the same column of luminous elements of the active matrix.

10. Display device according to claim 9, wherein the first driver (20) has $p=n/k$ outputs and the second driver (30) has $q=m*k$ outputs.

11. Display device according to claim 10, wherein k outputs of the second driver (30) are connected to luminous elements of a same column, each one of said k outputs being connected to luminous elements associated to a same colour component and each output of the first driver (20) is connected to all luminous elements associated to a same colour component and belonging to a same column of luminous elements and to k rows of luminous elements of the active matrix.

12. Display device according to any one of the preceding claims, wherein the video information delivered to the second driver (30) are based on sets of reference signals, a different set of reference signals being associated to at least two different colour components and wherein the digital processing unit (40) controls the first driver and delivers video information and reference signals to the second driver such that, each time the luminous elements connected to an output of the first driver are selected, the digital processing unit delivers to the second driver the video information of the luminous elements selected by the first driver and the set of reference signals associated to the colour component of the selected luminous elements.

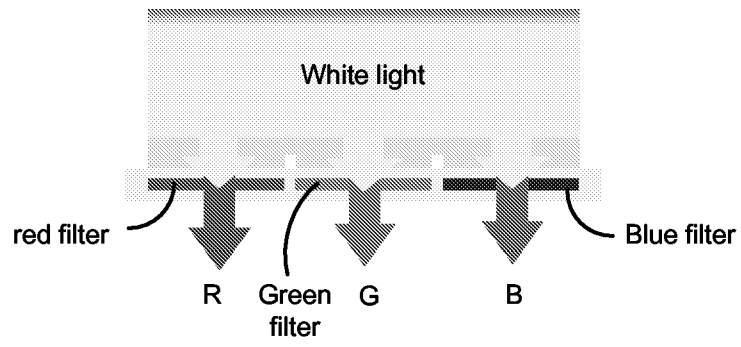

FIG.1

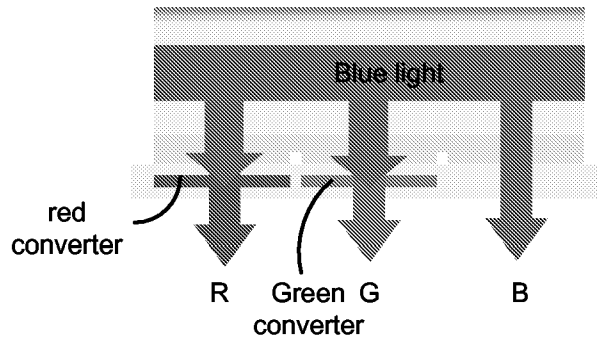

FIG.2

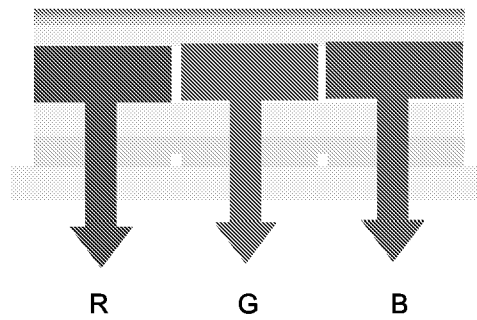

FIG.3

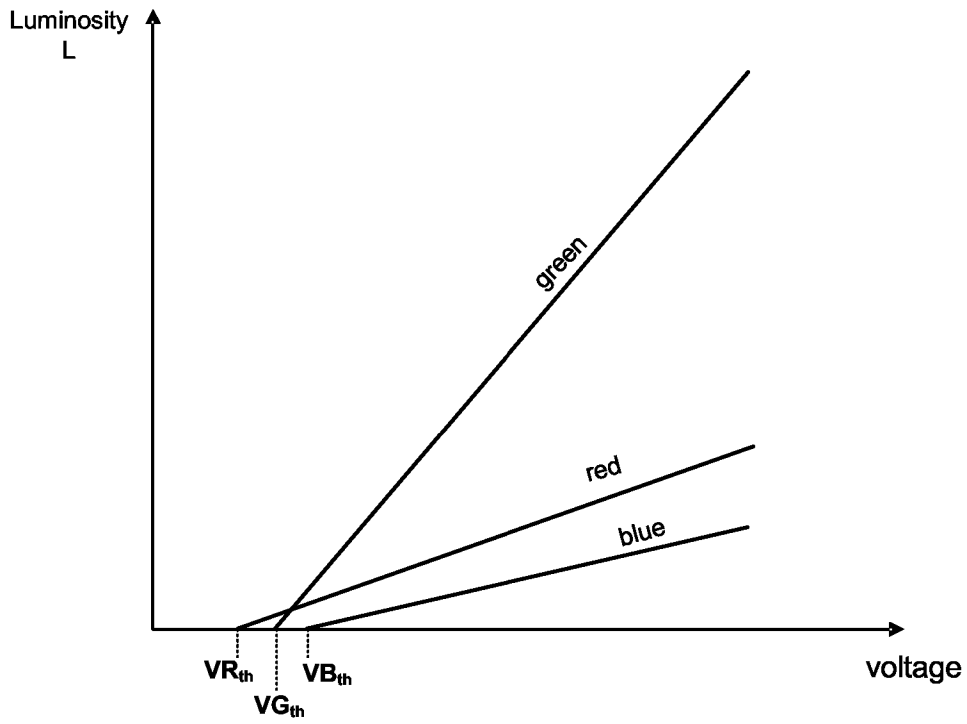

FIG.4

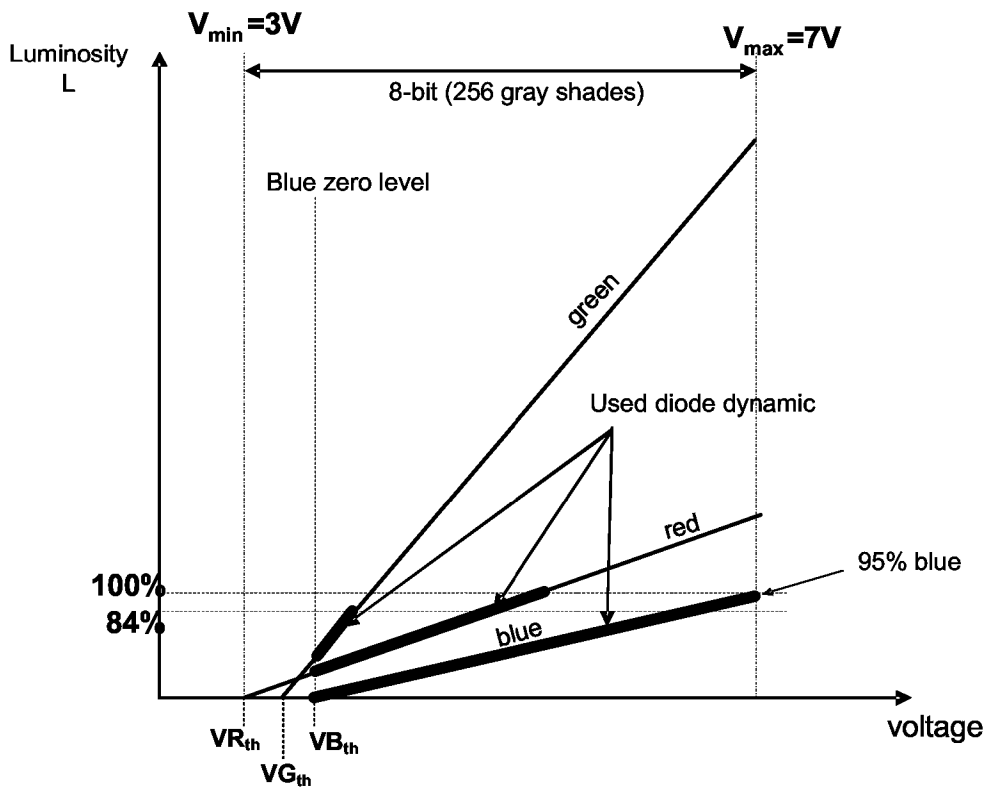

FIG.5

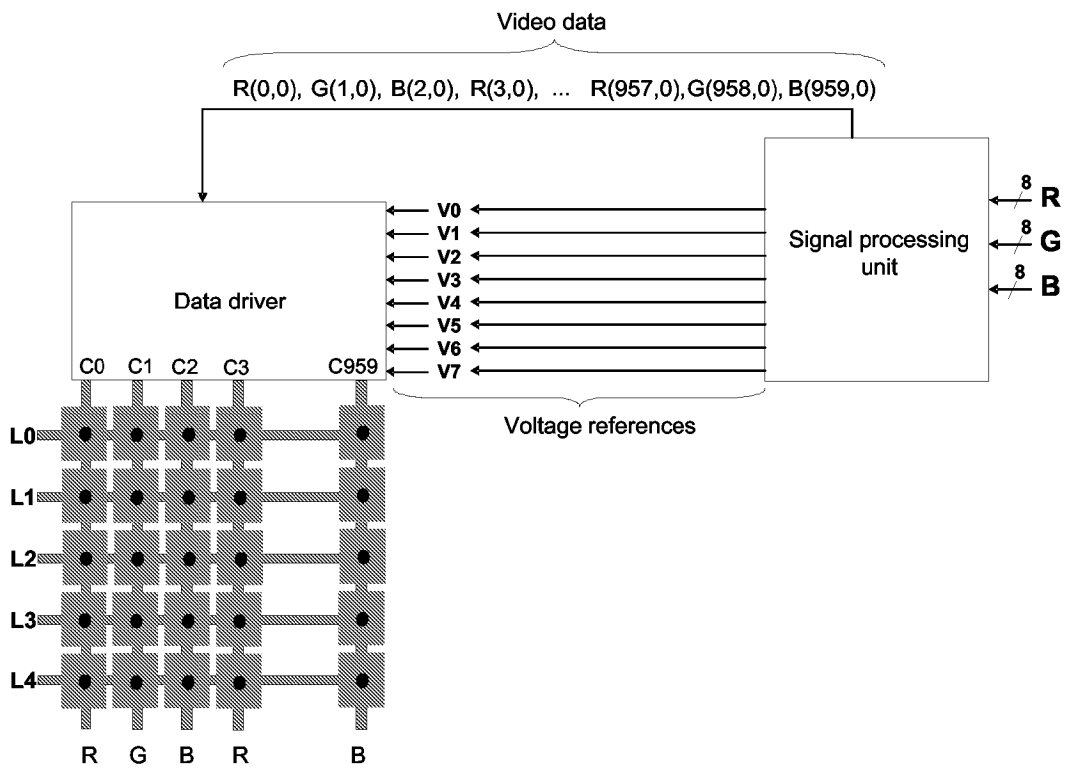

FIG.6 (prior art)

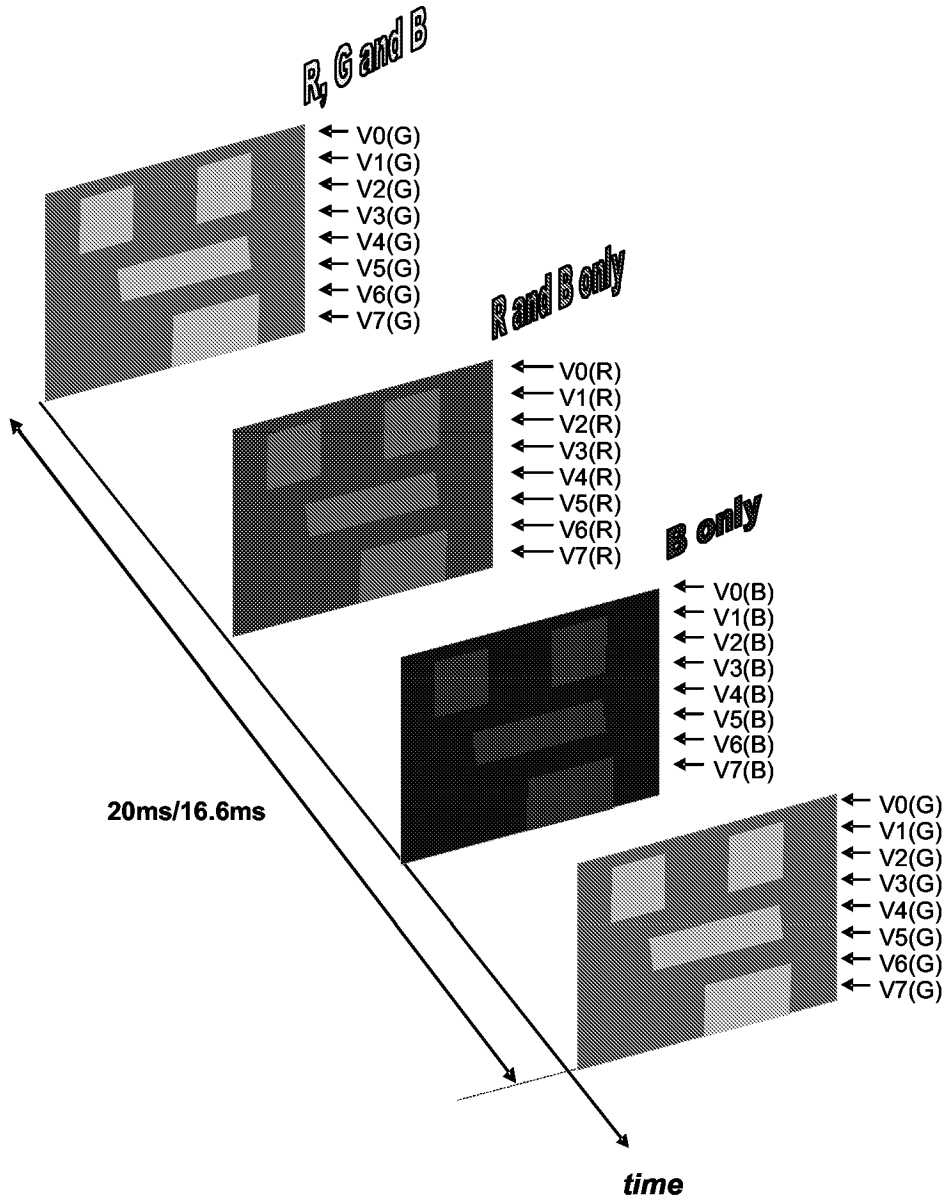

FIG.7

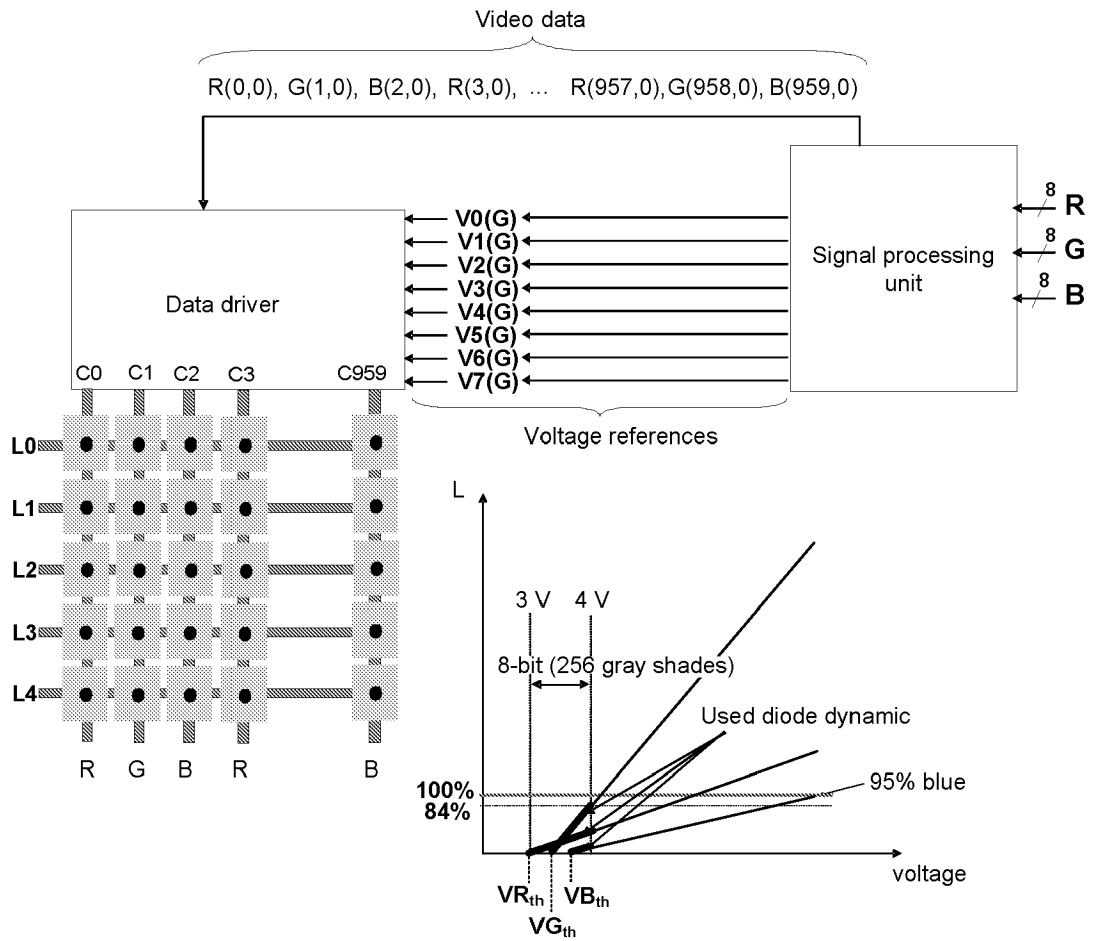

FIG.8

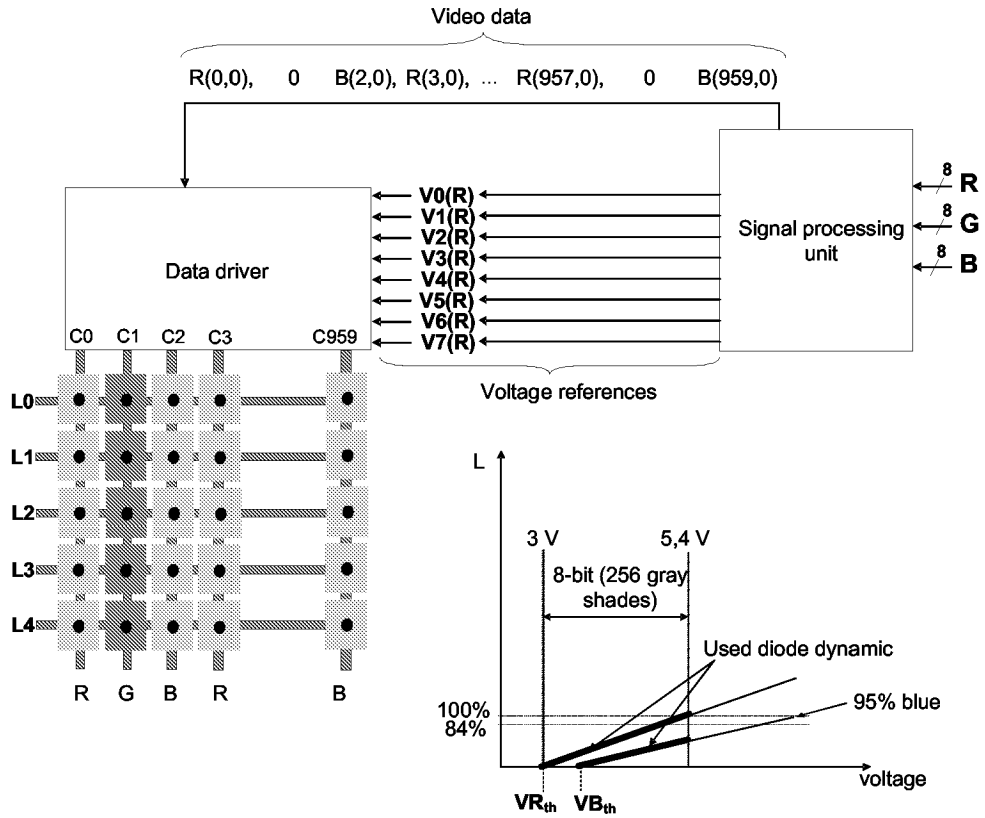

FIG.9

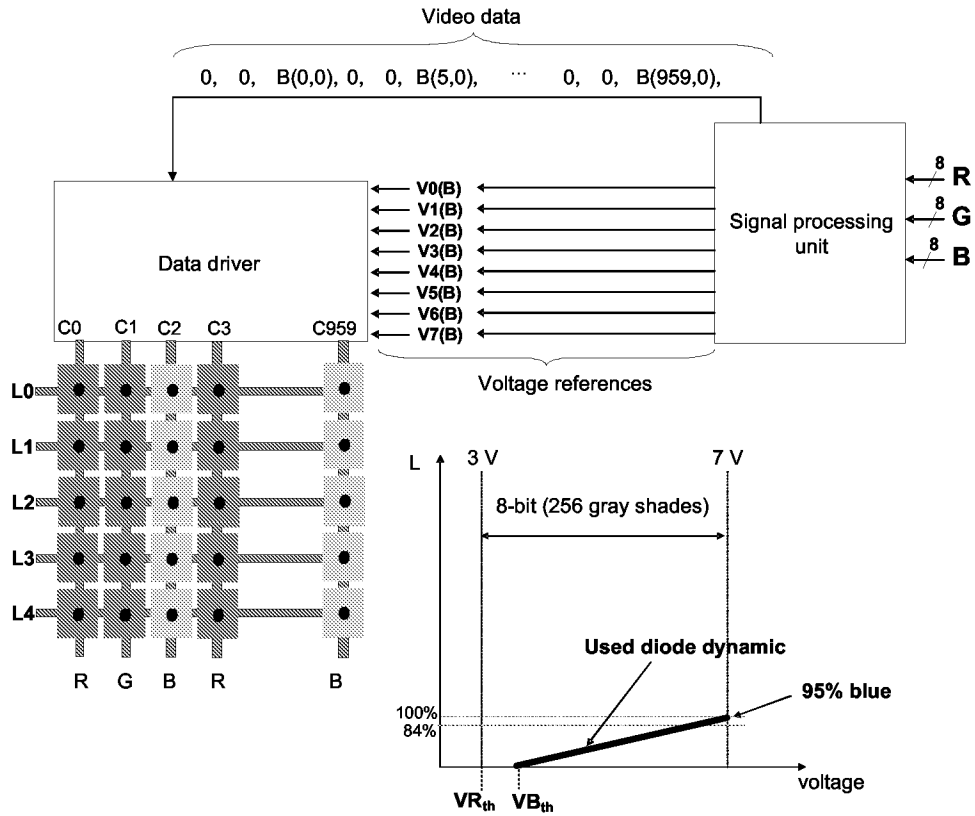

FIG.10

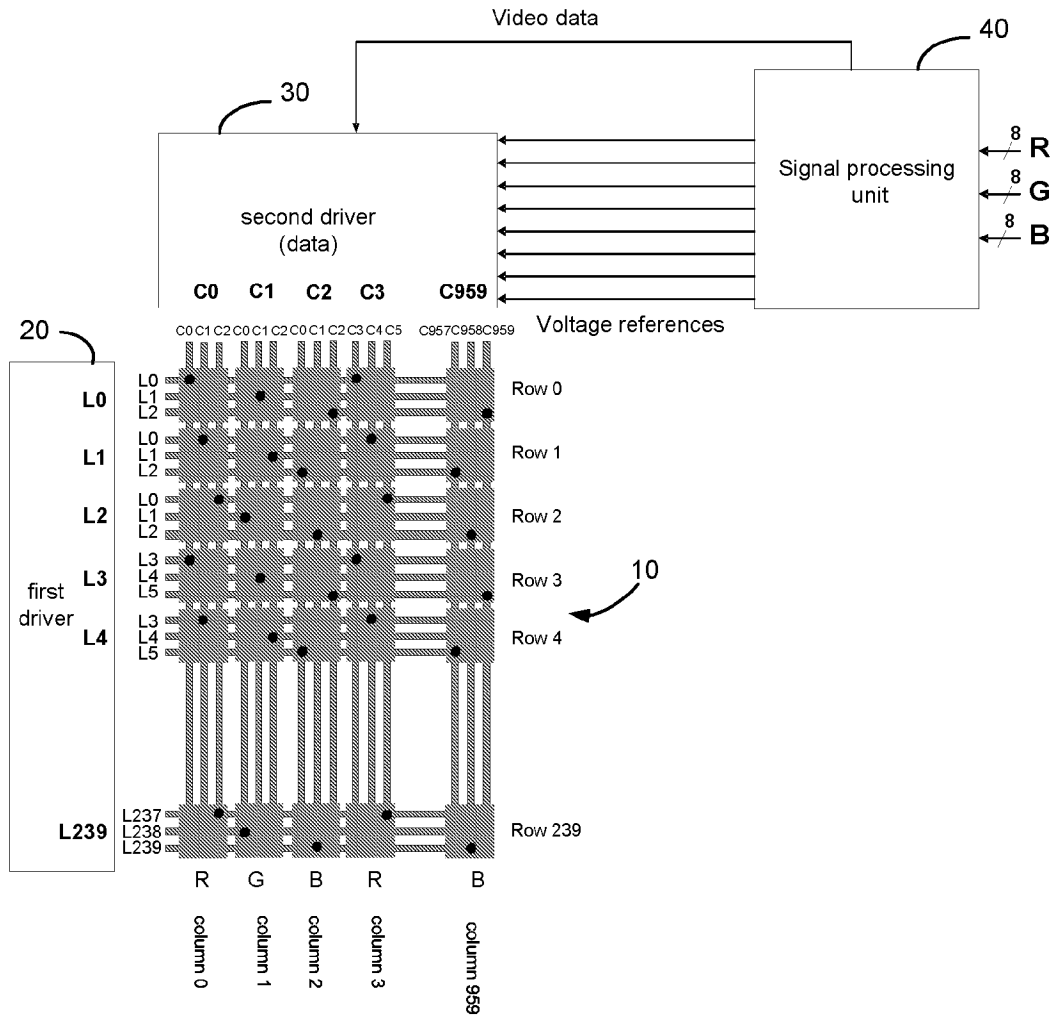

FIG.11

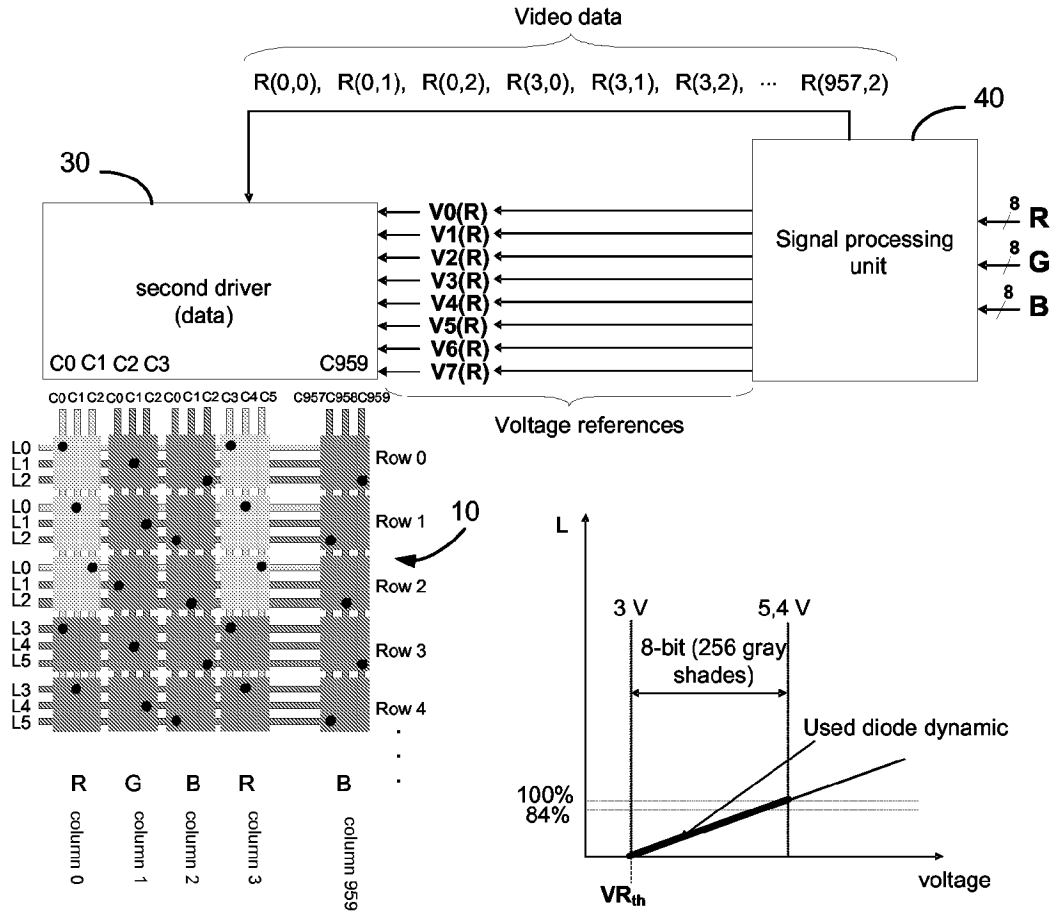

FIG.13

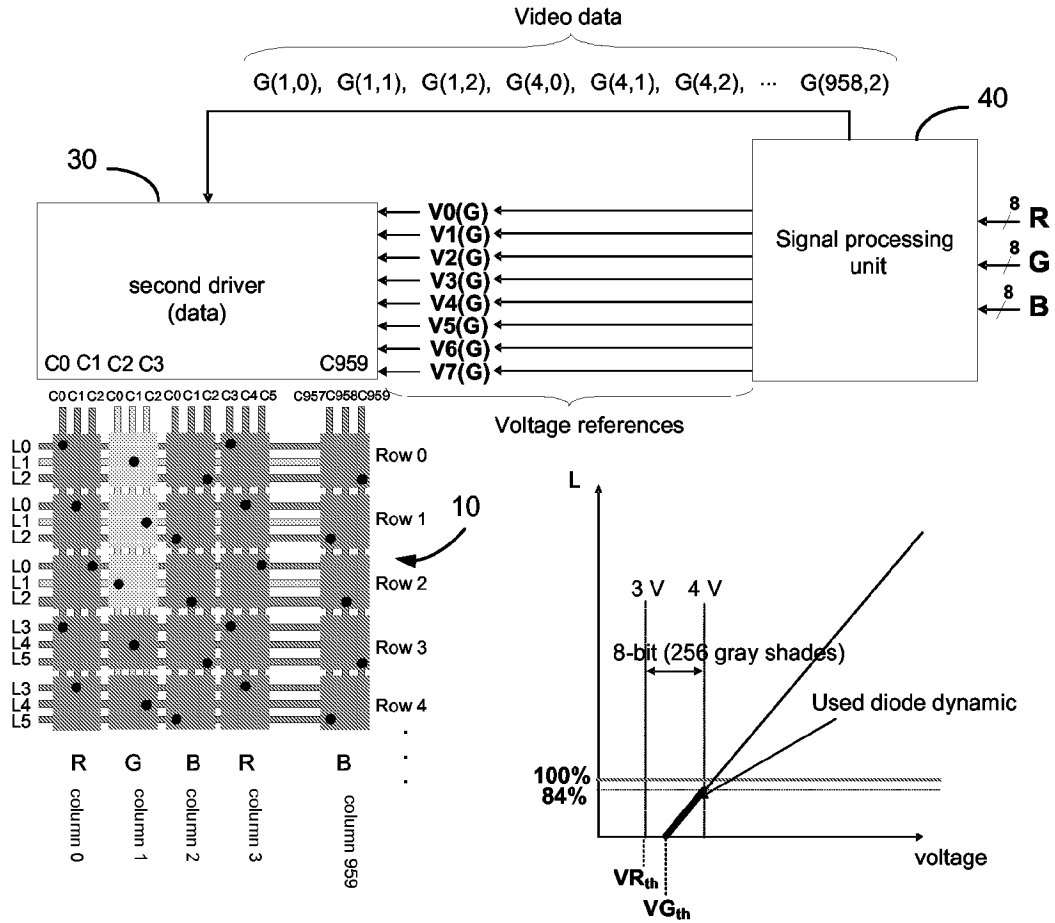

FIG.14

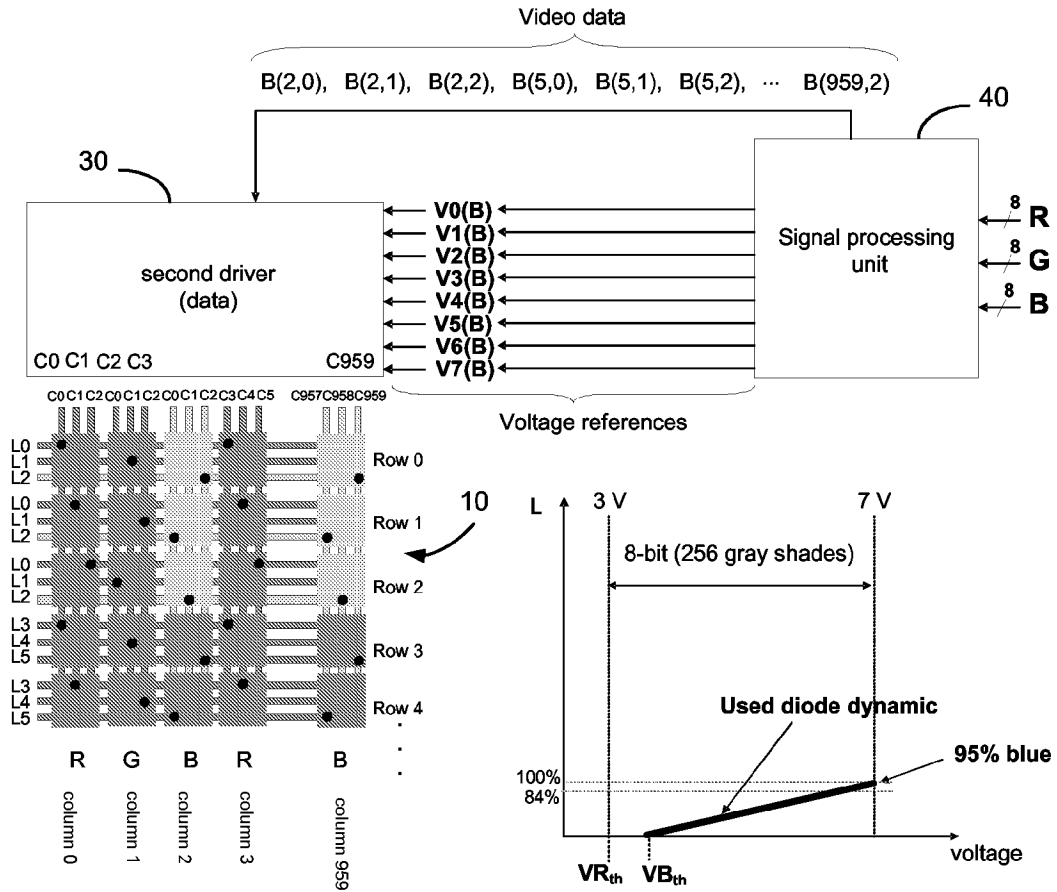

FIG.15

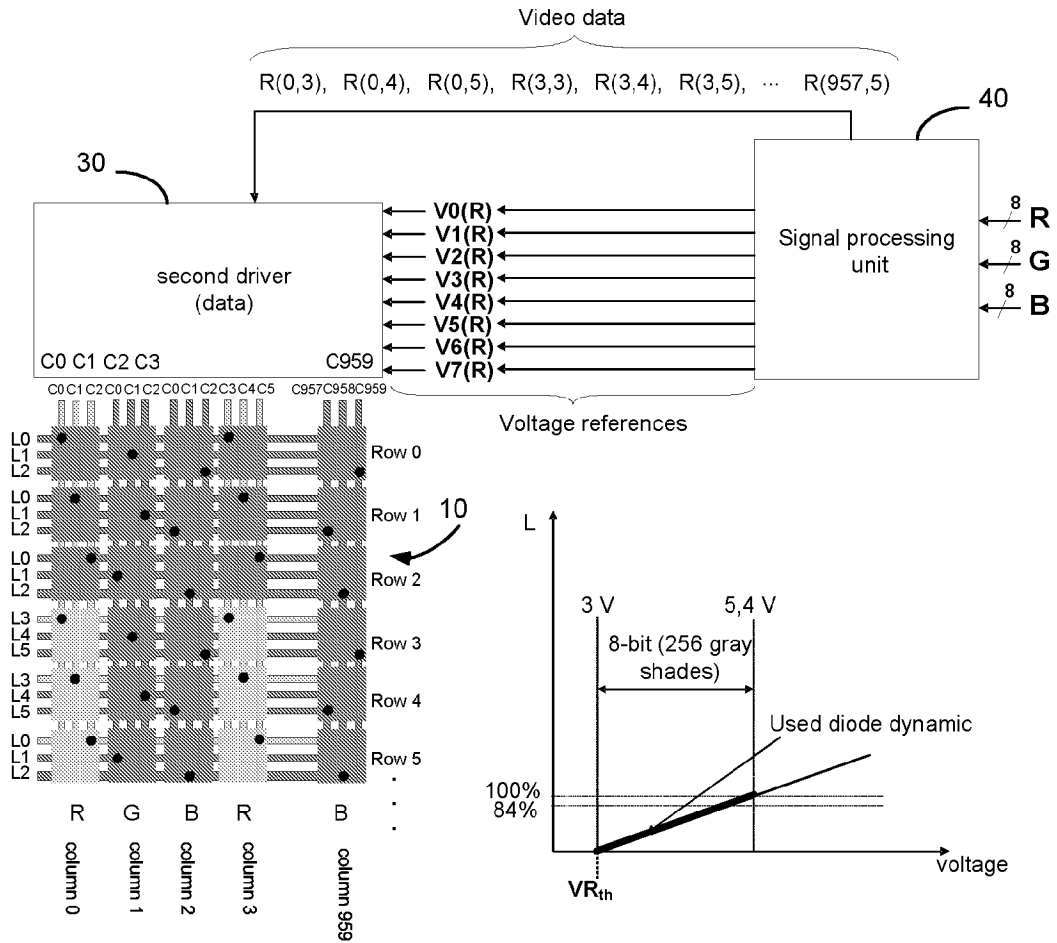

FIG.16

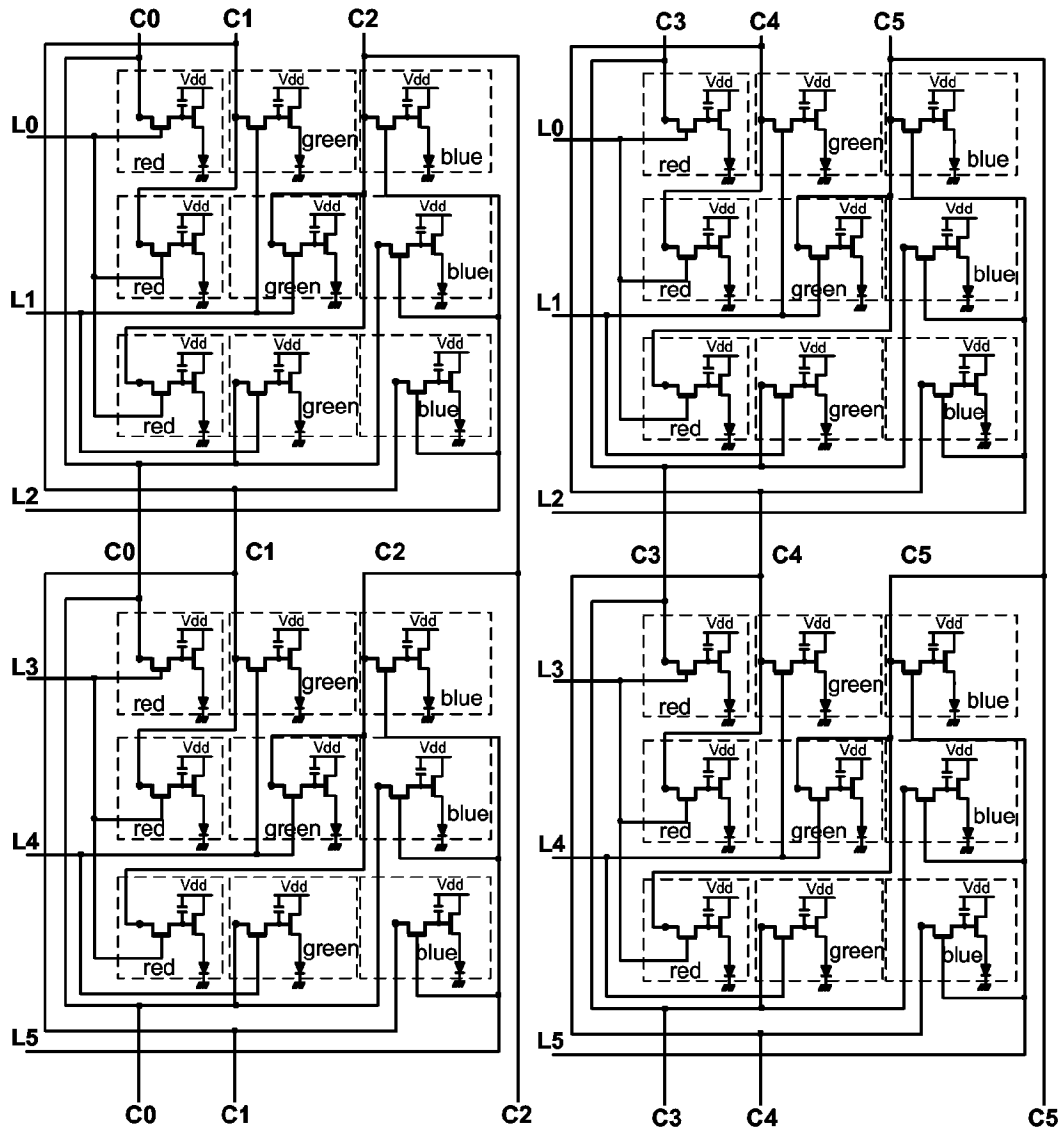

FIG.17

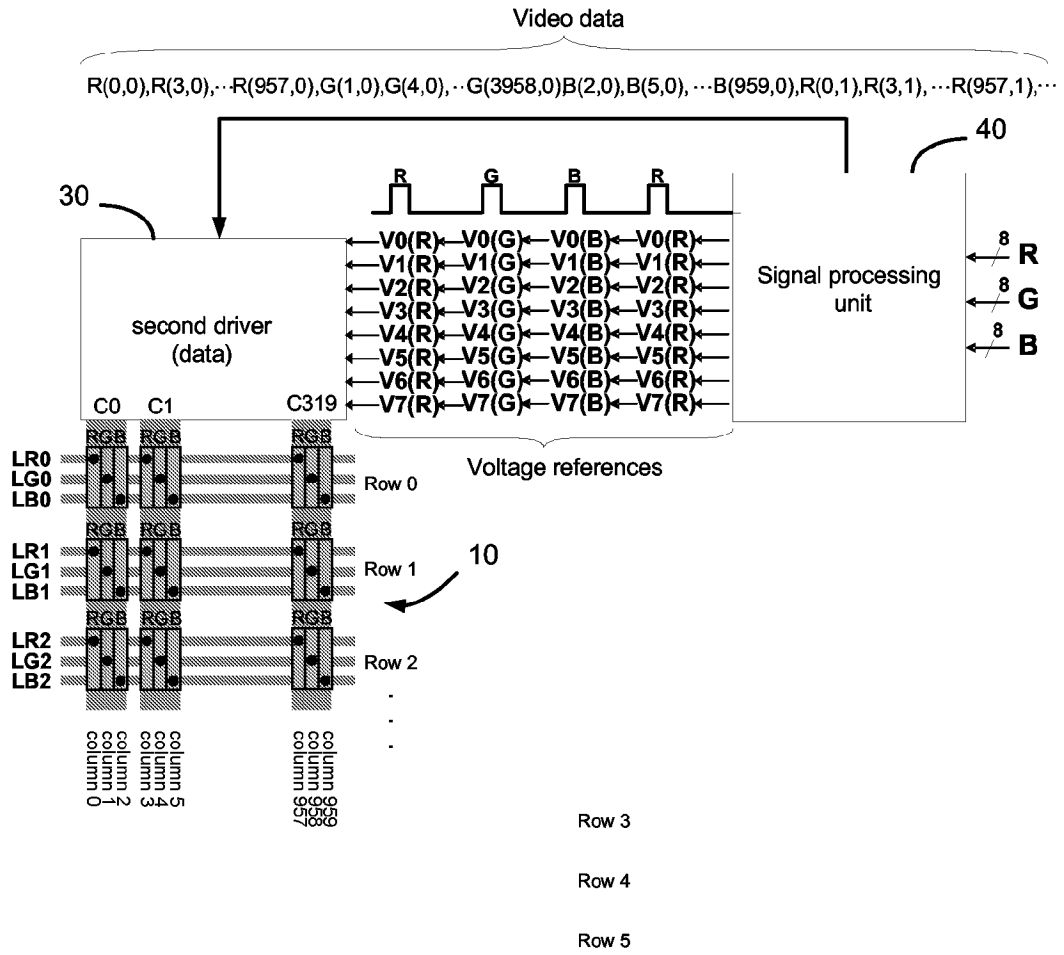

FIG.18

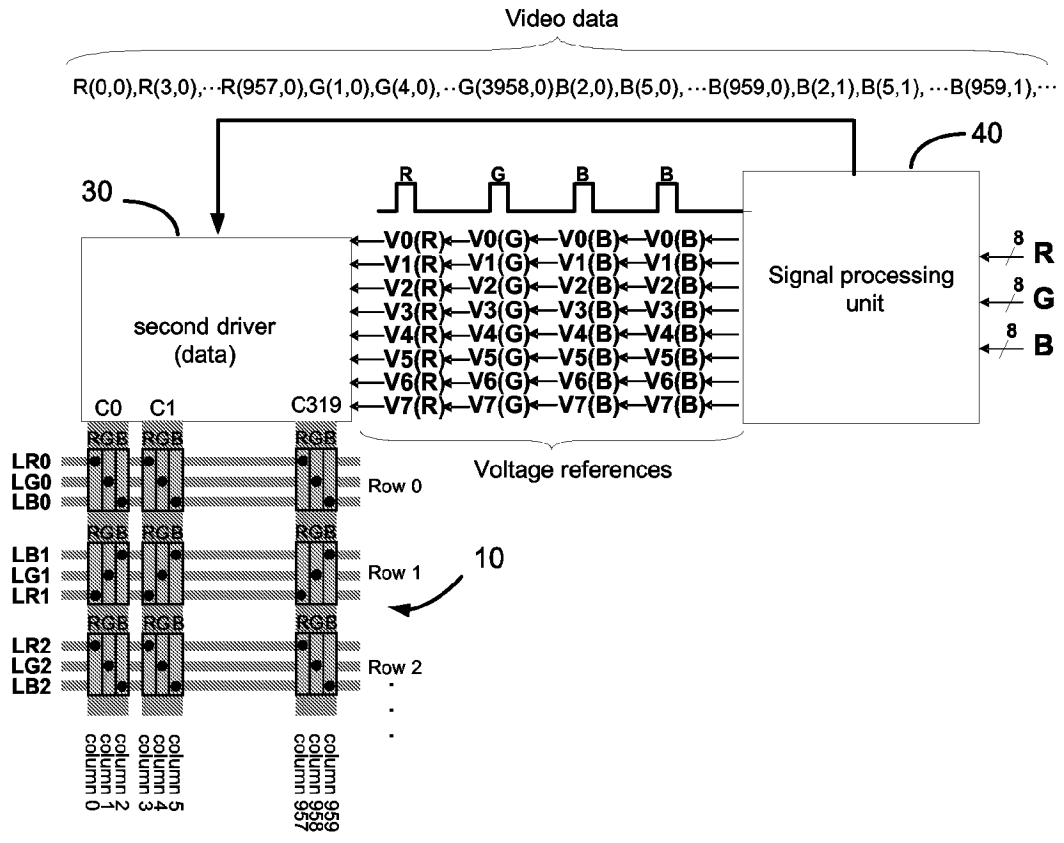

FIG. 19

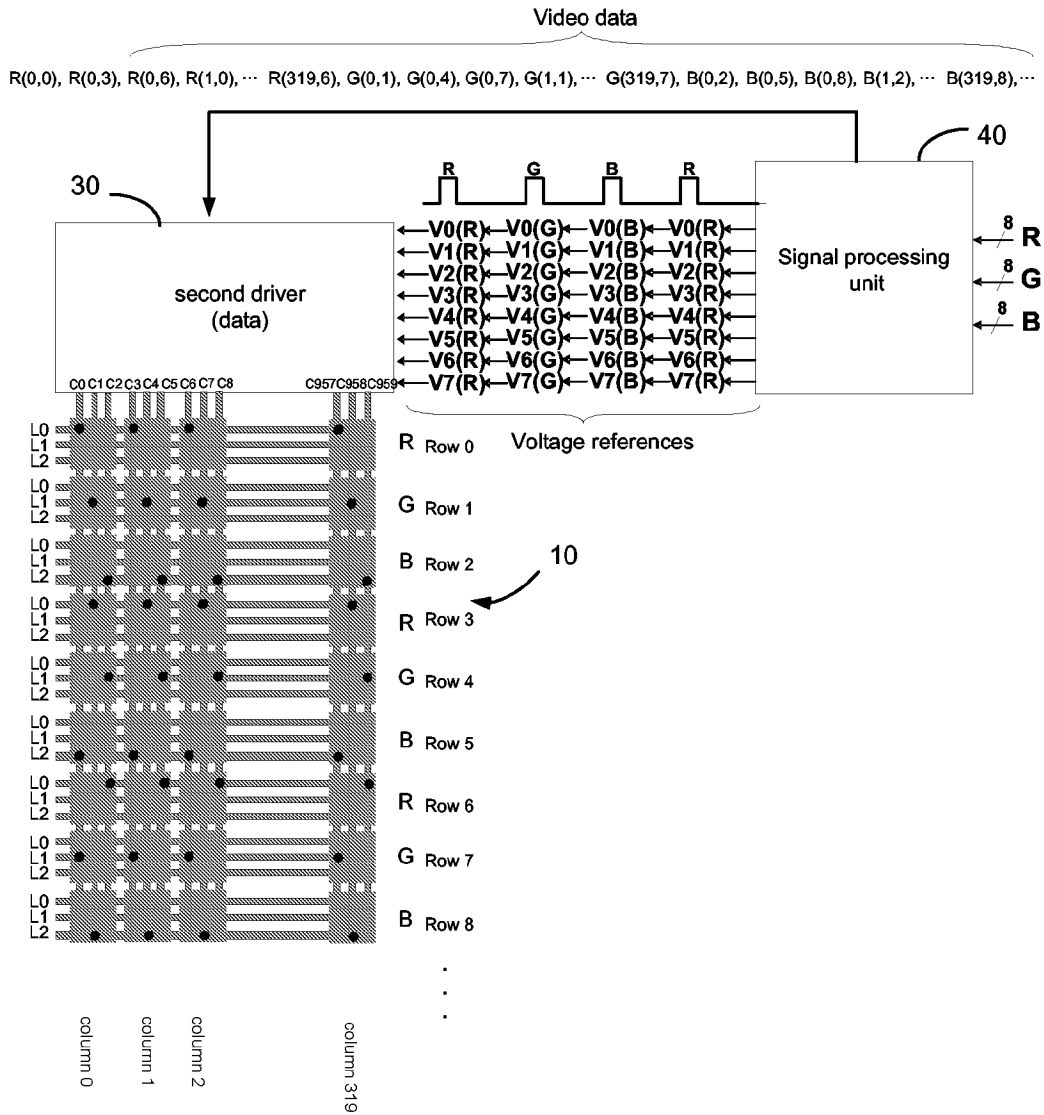

FIG.20



DOCUMENTS CONSIDERED TO BE RELEVANT			
Category	Citation of document with indication, where appropriate, of relevant passages	Relevant to claim	CLASSIFICATION OF THE APPLICATION (IPC)
X	US 2005/242743 A1 (KWAK WON-KYU [KR]) 3 November 2005 (2005-11-03) * figures 2-4 * * paragraphs [0046], [0047], [0052] * -----	1,2,5-7,9	INV. G09G3/32
X	EP 1 291 841 A (SEIKO EPSON CORP [JP]) 12 March 2003 (2003-03-12) * figures 6,10 * * paragraphs [0001], [0047], [0049], [0086], [0087], [0091], [0092] * * paragraphs [0133] - [0154] * -----	1,2,9,12	
A	US 2003/043132 A1 (NAKAMURA NORIO [JP]) 6 March 2003 (2003-03-06) * figures 1-3 * * paragraphs [0035] - [0046] * -----	12	
			TECHNICAL FIELDS SEARCHED (IPC)
			G09G H01L
The present search report has been drawn up for all claims			
Place of search		Date of completion of the search	Examiner
The Hague		17 November 2006	Ladiray, Olivier
CATEGORY OF CITED DOCUMENTS		T : theory or principle underlying the invention E : earlier patent document, but published on, or after the filing date D : document cited in the application L : document cited for other reasons & : member of the same patent family, corresponding document	
X : particularly relevant if taken alone Y : particularly relevant if combined with another document of the same category A : technological background O : non-written disclosure P : intermediate document			

2
EPO FORM 1503 03 82 (P04C01)

ANNEX TO THE EUROPEAN SEARCH REPORT
ON EUROPEAN PATENT APPLICATION NO.

EP 06 30 0737

This annex lists the patent family members relating to the patent documents cited in the above-mentioned European search report. The members are as contained in the European Patent Office EDP file on
The European Patent Office is in no way liable for these particulars which are merely given for the purpose of information.

17-11-2006

Patent document cited in search report	Publication date	Patent family member(s)	Publication date
US 2005242743 A1	03-11-2005	KR 20050104585 A	03-11-2005
-----	-----	-----	-----
EP 1291841 A	12-03-2003	CN 1405750 A	26-03-2003
		CN 1645460 A	27-07-2005
		JP 2004054188 A	19-02-2004
		TW 571273 B	11-01-2004
		US 2003062844 A1	03-04-2003
-----	-----	-----	-----
US 2003043132 A1	06-03-2003	JP 2003157051 A	30-05-2003
		TW 558700 B	21-10-2003
-----	-----	-----	-----

REFERENCES CITED IN THE DESCRIPTION

This list of references cited by the applicant is for the reader's convenience only. It does not form part of the European patent document. Even though great care has been taken in compiling the references, errors or omissions cannot be excluded and the EPO disclaims all liability in this regard.

Patent documents cited in the description

- EP 05292435 A [0013] [0015]

专利名称(译)	有源矩阵有机发光显示器 (amoled) 器件		
公开(公告)号	EP1873744A1	公开(公告)日	2008-01-02
申请号	EP2006300737	申请日	2006-06-30
[标]申请(专利权)人(译)	德国汤姆逊 - 布朗特公司 汤姆森特许公司		
申请(专利权)人(译)	DEUTSCHE THOMSON BRANDT 汤姆森许可		
当前申请(专利权)人(译)	DEUTSCHE THOMSON BRANDT 汤姆森许可		
[标]发明人	WEITBRUCH SEBASTIEN DOSER INGO TOBIAS THIEBAUD SYLVAIN		
发明人	WEITBRUCH, SÉBASTIEN DOSER, INGO TOBIAS THIEBAUD, SYLVAIN		
IPC分类号	G09G3/32		
CPC分类号	G09G3/3225 G09G3/3233 G09G3/3266 G09G3/3291 G09G2300/0452 G09G2300/0842 G09G2320/0271		
代理机构(译)	LE DANTEC , CLAUDE		
外部链接	Espacenet		

摘要(译)

有源矩阵OLED (有机发光显示器) 装置本发明涉及有源矩阵OLED (有机发光显示器) 装置。它包括与不同颜色成分 (红色 , 绿色 , 蓝色) 相关的发光元素矩阵。根据本发明, 行驱动器 (20) 和/或数据驱动器 (30) 与矩阵的发光元件的连接被修改。行驱动器的每个输出连接到与相同颜色分量 (红色或绿色或蓝色) 相关联的发光元件

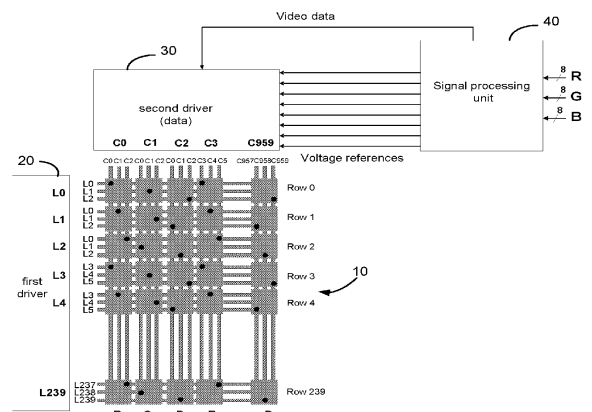

FIG. 11