



(12) **EUROPEAN PATENT APPLICATION**

(43) Date of publication: **21.12.2005 Bulletin 2005/51** (51) Int Cl.<sup>7</sup>: **H01L 51/20, H01L 27/00**

(21) Application number: **05012738.0**

(22) Date of filing: **14.06.2005**

(84) Designated Contracting States:  
**AT BE BG CH CY CZ DE DK EE ES FI FR GB GR  
 HU IE IS IT LI LT LU MC NL PL PT RO SE SI SK TR**  
 Designated Extension States:  
**AL BA HR LV MK YU**

(72) Inventor: **Park, Chong Hyun**  
**Daegu (KR)**

(74) Representative: **Zech, Stefan Markus et al**  
**Meissner, Bolte & Partner GbR**  
**(Depotstrasse 5 1/2, 86199 Augsburg)**  
**Postfach 10 26 05**  
**86016 Augsburg (DE)**

(30) Priority: **16.06.2004 KR 2004044331**

(71) Applicant: **LG ELECTRONICS INC.**  
**Seoul (KR)**

(54) **Organic electro-luminescence display device and fabricating method thereof**

(57) This invention relates to an organic electro-luminescence display device and a fabricating method thereof that are adaptive for improving an adhesion of a sealant used in an encapsulation process.

with having an organic light-emitting layer therebetween; a cap adhered via a sealant to a seal line area; a plurality of signal lines connected to any one of the first and the second electrodes and located on the seal line area; and a dummy insulating pattern formed to cover any one of the signal lines, wherein a portion of the dummy insulating pattern is formed on the seal line area.

An organic electro-luminescence display device according to the present invention includes: a substrate provided with an organic electro-luminescence array having first and second electrodes crossing each other

**FIG.5**

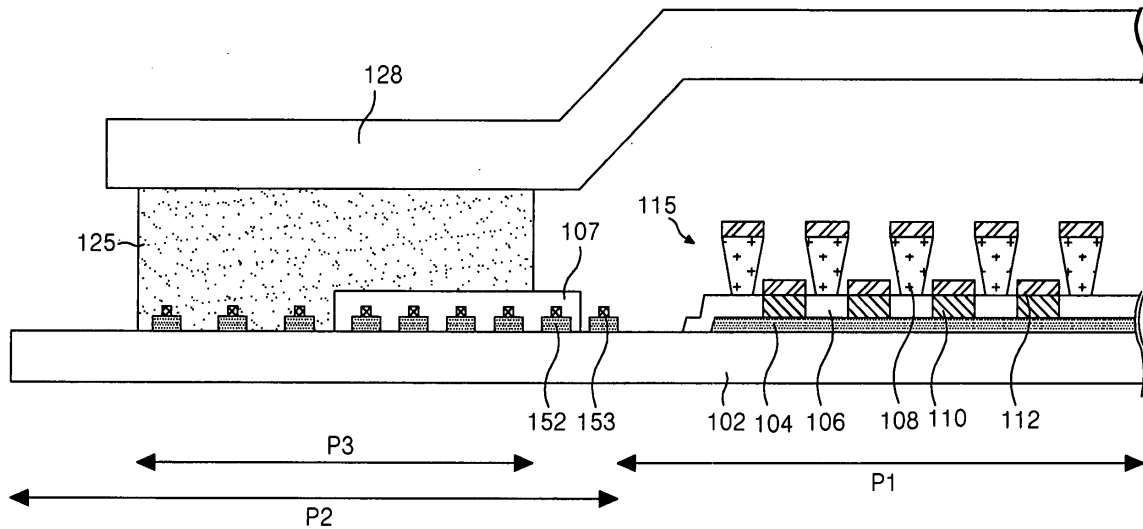

## Description

[0001] This application claims the benefit of Korean Patent Application No. P2004-44331 filed in Korea on June 16, 2004, which is hereby incorporated by reference.

## BACKGROUND OF THE INVENTION

### FIELD OF THE INVENTION

[0002] This invention relates to an electro-luminescence display (ELD), and more particularly, to an organic electro-luminescence display device and a fabricating method thereof that are adaptive for improving an adhesion of a sealant used in an encapsulation process.

### Description of the Related Art

[0003] Recently, there have been developed various flat panel display devices reduced in weight and bulk that is capable of eliminating disadvantages of a cathode ray tube (CRT). Such flat panel display devices include a liquid crystal display (LCD), a field emission display (FED), a plasma display panel (PDP) and an electro-luminescence (EL) display, etc. device. In such flat panel display devices, the PDP has the most advantage for making a large dimension screen because its structure and manufacturing process are simple, but has a drawback in that it has low light-emission efficiency and large power consumption. The LCD has a difficulty in making a large dimension screen because it is fabricated by a semiconductor process, but has an expanded demand as it is mainly used for a display device of a notebook personal computer. However, the LCD has a drawback in that it has a difficulty in making a large dimension screen and it has large power consumption due to a backlight unit. Also, the LCD has characteristics of a large light loss and a narrow viewing angle due to optical devices such as a polarizing filter, a prism sheet, a diffuser and the like. On the other hand, the EL display device is largely classified into an inorganic EL device and an organic EL device depending upon a material of a light-emitting layer, and is a self-luminous device. When compared with the above-mentioned display devices, the EL display device has advantages of a fast response speed, large light-emission efficiency, a large brightness and a large viewing angle. The organic EL display device can display a picture at approximately 10 [V] and a high brightness of ten thousands of [cd/m<sup>2</sup>]. The organic EL display device is largely used for a mini type display such as mobile phone and the like.

[0004] FIG. 1 is a schematic view showing a related art organic EL display device, and FIG. 2 is a sectional view specifically illustrating 'A' area in FIG. 1.

[0005] Referring to FIG. 1 and FIG. 2, the related art EL display device includes: a display area P1 provided with an organic EL array; and a non-display area P2 pro-

vided with a pad portion 25 for applying driving signals to driving electrodes at the display area P1 and an adhering area P3(or seal line area) both of a cap 28 and a substrate 2.

5 [0006] The display area P1 is provided with an anode electrode 4 formed on the substrate 2, and a cathode electrode 12 formed in a direction crossing the anode electrode 4.

10 [0007] A plurality of anode electrodes 4 are provided on the substrate 2 in such a manner to be spaced at a desired distance from each other. The anode electrode 4 is partially exposed, to thereby form an insulating film 6 defining a light-emitting area on the substrate 2 having the anode electrode 4. On the insulating film 6, a barrier rib 8 for making a separation of an organic light-emitting layer 10 and the cathode electrode 12 to be formed thereon is provided. The barrier rib 8 is formed in a direction crossing the anode electrode 4, and has an overhang structure in which the upper portion thereof has a larger width than the lower portion thereof. The organic light-emitting layer 10 made of an organic compound and the cathode electrode 12 are entirely deposited onto the insulating film 6 provided with the barrier rib 8. The organic light-emitting layer 10 is formed by depositing a hole injection layer, a hole carrier layer, a light-emitting layer, an electron carrier layer and an electron injection layer onto the anode electrode 4.

20 [0008] The non-display area P2 is provided with a first line 54 extended from the anode electrode 4 at the display area P1, data pads for supplying data voltages, via the first line 54, to the anode electrode 4, a second line 52 connected to the cathode electrode 12, and scan pads for supplying scan voltages via the second line 52. Herein, the first and the second lines 54 and 52 are formed of the same transparent electrode material as the anode electrode 4, and a conductive metal layer 53 is further formed of molybdenum and the like, on the second line 52 in order to reinforce a conductivity of the second line 52.

30 [0009] The data pad is connected to a tape carrier package (TCP) mounted with a first driving circuit for generating data voltages to thereby supply the data voltage to each anode electrode 4. The scan pad is provided at each side of the data pad. The scan pad is connected to a TCP mounted with a second driving circuit for generating scan voltages, to thereby supply the scan voltage to each cathode electrode 12.

35 [0010] The cap 28, adhered to the substrate 2 via the sealant 25 at the seal line area P3 of the non-display area P2, prevents the organic EL array 15 of the display area P1 from oxygen and moisture in the area.

40 [0011] As shown in FIG. 3, in the related art organic EL display device having the structure as mentioned above, if a voltage is applied between the anode electrode 4 and the cathode electrode 12, then electrons (or cathodes) generated from the cathode electrode 12 are moved, via an electron injection layer 10a and an electron carrier layer 10b, into a light-emitting layer 10c. On

the other hand, holes (or anodes) generated from the anode electrode 4 are moved, via a hole injection layer 10e and a hole carrier layer 10d, into the light-emitting layer 10c.

[0012] Accordingly, in the light-emitting layer 10c, the electron and the hole supplied from the electron carrier layer 10b and the hole carrier layer 10d are recombined to form an exciton, and the exciton is excited again to a ground state, thus a light of a fixed energy is emitted to the outside through the anode electrode 4, so that a picture is displayed.

[0013] Meanwhile, in such an organic EL display device, the second line 52 turns around the display area P1 to connect to the scan pad, so that a plurality of second lines 52 are located at the seal line area P3 as shown in FIG. 4. The second lines 52 are densely arranged it is goes from the seal line area P3 to the display area P1. Accordingly, there is a problem that the sealant 25 is not uniformly at the seal line area P3 upon adhering the cap to the substrate 2, as shown in FIG. 4. In other words, since the densely arranged second line 52 prevents that the sealant 25 is uniformly spread to the seal line area P3 upon adhering the can 28 to the substrate, a width of the spread sealant 25 becomes uneven.

[0014] Accordingly, in a case that an adhesive power both of the substrate 2 and the cap 28 becomes lowered and an unbalance pressure is generated at a fixed area, there is a problem of a packaging badness, i. e., the sealant 25 is partially broken.

### SUMMARY OF THE INVENTION

[0015] Accordingly, it is an object of the present invention to provide an organic electro-luminescence display device and a fabricating method thereof that are adaptive for improving an adhesion of a sealant used in an encapsulation process.

[0016] In order to achieve these and other objects of the invention, an organic electro-luminescence display device according to an embodiment of the present invention includes: a substrate provided with an organic electro-luminescence array having first and second electrodes crossing each other with having an organic light-emitting layer therebetween; a cap adhered via a sealant to a seal line area; a plurality of signal lines connected to any one of the first and the second electrodes and located on the seal line area; and a dummy insulating pattern formed to cover any one of the signal lines, wherein a portion of the dummy insulating pattern is formed on the seal line area.

[0017] The dummy insulating pattern is overlapped with a portion of the seal line area adjacent to the organic electro-luminescence array.

[0018] The dummy insulating pattern is overlapped with the seal line area as much as more than 1/2 of the entire width of the seal line area.

[0019] The signal lines are arranged by a narrower distance as it is goes from the seal line area to the or-

ganic electro-luminescence array, and the dummy insulating pattern is formed to cover at least one signal line located at the seal line area adjacent to the organic electro-luminescence array.

5 [0020] The dummy insulating pattern is formed to cover more than 1/2 of the signal lines.

[0021] The organic electro-luminescence display device further includes an insulating film formed on the first electrode to define a light-emitting area, wherein the dummy insulating pattern is the same material as the insulating film.

10 [0022] A method of fabricating an organic electro-luminescence display device according to an embodiment of the present invention includes: forming an organic electro-luminescence array having first and second electrodes crossing each other with having an organic light-emitting layer therebetween; providing a cap adhered via a sealant to a seal line area; forming a plurality of signal lines connected to any one of the first and the second electrodes and located on the seal line area; and forming a dummy insulating pattern to cover any one of the signal lines, wherein a portion of the dummy insulating pattern is formed on the seal line area.

15 [0023] The organic electro-luminescence array includes an insulating film defining the light-emitting area by partially exposing the first electrode, and the dummy insulating pattern is simultaneously formed of the same material as the insulating film.

### 20 BRIEF DESCRIPTION OF THE DRAWINGS

[0024] These and other objects of the invention will be apparent from the following detailed description of the embodiments of the present invention with reference to the accompanying drawings, in which:

25 [0025] FIG. 1 is a schematic view showing a structure of a related art organic electro-luminescence display device;

[0026] FIG. 2 is a sectional view specifically illustrating 'A' area in FIG. 1;

30 [0027] FIG. 3 is a diagram for explaining a light-emitting principle of the organic electro-luminescence display device;

[0028] FIG. 4 is a sectional view for explaining a formation badness of the related art sealant;

35 [0029] FIG. 5 is a sectional view specifically illustrating a portion of the organic electro-luminescence display device according to the present invention; and

[0030] FIG. 6A to FIG. 6G are sectional views for sequentially explaining a method of fabricating the organic electro-luminescence display device shown in FIG. 5.

### 40 DETAILED DESCRIPTION OF THE PREFERRED EMBODIMENT

45 [0031] Reference will now be made in detail to the preferred embodiments of the present invention, examples of which are illustrated in the accompanying drawings.

**[0032]** Hereinafter, the preferred embodiments of the present invention will be described in detail with reference to FIGs. 5 to 6G.

**[0033]** FIG. 5 is a schematic section view showing a portion of an organic electro-luminescence display device according to the present invention.

**[0034]** Referring to FIG. 5, the organic EL display device according to the present invention includes: a display area P1 provided with an organic EL array 115; and a non-display area P2 provided with a pad portion(not shown) for applying driving signals to driving electrodes at the display area P1 and an adhering area P3(or seal line area) both of a cap 128 and a substrate 102.

**[0035]** The display area P1 is provided with an anode electrode 104 formed on the substrate 102, and a cathode electrode 112 formed in a direction crossing the anode electrode 104.

**[0036]** A plurality of anode electrodes 104 are provided on the substrate 102 in such a manner to be spaced at a desired distance from each other. The anode electrode 104 is partially exposed, to thereby form an insulating film 106 defining a light-emitting area on the substrate 102 having the anode electrode 104. On the insulating film 106, a barrier rib 108 for making a separation of an organic light-emitting layer 110 and the cathode electrode 112 to be formed thereon is provided. The barrier rib 108 is formed in a direction crossing the anode electrode 104, and has an overhang structure in which the upper portion thereof has a larger width than the lower portion thereof. The organic light-emitting layer 110 made of an organic compound and the cathode electrode 112 are entirely deposited onto the insulating film 106 provided with the barrier rib 108. The organic light-emitting layer 110 is formed by depositing a hole injection layer, a hole carrier layer, a light-emitting layer, an electron carrier layer and an electron injection layer onto the anode electrode 104.

**[0037]** The non-display area P2 is provided with a first line(not shown) extended from the anode electrode 104 at the display area P1, data pads for supplying data voltages, via the first line, to the anode electrode 104, a second line 152 connected to the cathode electrode 112, and scan pads for supplying scan voltages via the second line 152. Herein, the first line and the second line 152 are formed of the same transparent electrode material as the anode electrode 104, and a conductive metal layer 153 is further formed of molybdenum and the like, on the second line 152 in order to reinforce a conductivity of the second line 152.

**[0038]** The cap 128, adhered to the substrate 102 via the sealant 125 at the seal line area P3 of the non-display area P2, prevents the organic EL array 115 of the display area P1 from oxygen and moisture in the area.

**[0039]** The organic EL display device according to the present invention further includes a dummy insulating pattern 107 at the seal line area P3 of the non-display area P2. The dummy insulating pattern 107 is formed to cover the second lines 152 densely located in the seal

line area P3, so that the sealant 125 is corresponded to the seal line area P3 and is uniformly formed.

**[0040]** More specifically, this will be described as follows.

**[0041]** A portion of the second line 152, turning around the display area P1 to connect to the scan pad, is located at the seal line area P3, especially, becomes densely arranged as it goes from the seal line area P3 to the display area P1. Herein, the dummy insulating pattern 107 is formed to cover the densely arranged second line 152. And, the sealant 125 is located on the dummy insulating pattern 107, so that it is possible to prevent an uneven formation of the sealant caused by the second line 152 as compared with the related art. The dummy insulating pattern 107 might be formed to be overlapped with the seal line area P3 of a direction adjacent to the display area P1 and to be partially further enlarged from the seal line area P3 to the display area P1 direction. Furthermore, the dummy insulating pattern 107 might be formed to be overlapped with the seal line area P2 as much as more than a half thereof. Meanwhile, the dummy insulating pattern 107 is formed of an organic material identical to the insulating film 106 of the organic EL array 115 and a thickness of the dummy insulating pattern 107 is approximately 1.2 $\mu$ m, and a thickness of the second line 152 is approximately 1000 $\text{\AA}$ , so that the dummy insulating pattern 107 can reduce a stepped difference between the second line 152 and the substrate 102.

**[0042]** Hereinafter, a method of fabricating the organic EL display device will be described with reference to FIGs. 6A to 6G.

**[0043]** Firstly, as shown in FIG. 6A, the anode electrode 104 and the second line 152 are provided by depositing a transparent conductive metal material onto the substrate 102 made of a sodalime or a vulcanized glass and then patterning it by the photolithography and the etching process. Herein, indium-tin-oxide (ITO) or SnO<sub>2</sub> is used as the metal material.

**[0044]** on the substrate 102, a conductive metal material such as molybdenum Mo and the like is deposited and is patterned by a photolithography process and an etching process, to thereby form the conductive metal layer 153 on the second line 152 as shown in FIG 6B.

**[0045]** A photosensitive insulating material is coated on the substrate 102 having the anode electrode 104 and the second line 152 by a spin-coating method, and is patterned, to thereby form the insulating film 106 defining a light-emitting area of the display area P1 and the dummy insulating pattern 107 on the seal line area P3 as shown in FIG. 6C. Herein, the dummy insulating pattern 107 is formed to cover the second line 152 densely arranged on the seal line area P3, and might be formed to be partially further enlarged from the seal line area P3 to the display area P1 direction.

**[0046]** A photosensitive insulating material is deposited on the substrate 102 having the insulating film 106 and the dummy insulating pattern 107, and is patterned

by a photolithography process and an etching process, to thereby form a barrier rib 108 as shown in FIG. 6D. The barrier rib 108 is formed at a non light-emitting area to be cross with the anode electrodes 104 in order to partition a pixel.

[0047] As shown in FIG. 6E, an organic light-emitting layer 110 is formed on the substrate 102 having the barrier rib 108 by a heat deposition, a vacuum deposition and the like using a common mask and a show mask, those are not shown.

[0048] A metal material is deposited on the substrate 102 having the organic light-emitting layer 110, to thereby form a cathode electrode 112 as shown in FIG. 6F.

[0049] Thereafter, the sealant 125 is applied to an area where the cap 128 and the substrate 102 are adhered, and then an encapsulating process is performed to make the sealant is corresponded to the seal line area P3 of the substrate 102, to thereby combine the cap 128 and the substrate 102 provided with the organic EL array 115 having the cathode electrode 112 as shown in FIG. 6G.

[0050] In the organic electro-luminescence display device and a fabricating method thereof, the dummy insulating pattern 107 is formed to cover the second line 152 (or signal line) located at the seal line area P3, that is adhering area of both the cap and the substrate. The dummy insulating pattern 107 reduces a stepped difference between the substrate 102 and the second line 152, so that the sealant 125 becomes uniformly formed at the seal line area P3. Hereby, the adhesion of the sealant 125 becomes improved, to thereby improve a packaging of the organic EL array 115.

[0051] As described above, in the organic electro-luminescence display device and a fabricating method thereof, the dummy insulating pattern is formed to cover the second line (or signal line) located at the seal line area, so that the dummy insulating pattern reduces a stepped difference between the substrate and the second line. Accordingly, the sealant becomes uniformly formed, so that it is possible to improve a packaging of the organic EL array.

[0052] Although the present invention has been explained by the embodiments shown in the drawings described above, it should be understood to the ordinary skilled person in the art that the invention is not limited to the embodiments, but rather that various changes or modifications thereof are possible without departing from the spirit of the invention. Accordingly, the scope of the invention shall be determined only by the appended claims and their equivalents.

## Claims

1. An organic electro-luminescence display device, comprising:

a substrate provided with an organic electro-lu-

minescence array having first and second electrodes crossing each other with having an organic light-emitting layer therebetween; a cap adhered via a sealant to a seal line area; a plurality of signal lines connected to any one of the first and the second electrodes and located on the seal line area; and a dummy insulating pattern formed to cover any one of the signal lines, wherein a portion of the dummy insulating pattern is formed on the seal line area.

2. The organic electro-luminescence display device according to claim 1, wherein the dummy insulating pattern is overlapped with a portion of the seal line area adjacent to the organic electro-luminescence array.

3. The organic electro-luminescence display device according to claim 2, wherein the dummy insulating pattern is overlapped with the seal line area as much as more than 1/2 of the entire width of the seal line area.

4. The organic electro-luminescence display device according to claim 1, wherein the signal lines are arranged by a narrower distance as it is goes from the seal line area to the organic electro-luminescence array, and the dummy insulating pattern is formed to cover at least one signal line located at the seal line area adjacent to the organic electro-luminescence array.

5. The organic electro-luminescence display device according to claim 4, wherein the dummy insulating pattern is formed to cover more than 1/2 of the signal lines.

6. The organic electro-luminescence display device according to claim 1, further comprising an insulating film formed on the first electrode to define a light-emitting area, wherein the dummy insulating pattern is the same material as the insulating film.

7. A method of fabricating an organic electro-luminescence display device, further comprising:

forming an organic electro-luminescence array having first and second electrodes crossing each other with having an organic light-emitting layer therebetween; providing a cap adhered via a sealant to a seal line area; forming a plurality of signal lines connected to any one of the first and the second electrodes and located on the seal line area; and forming a dummy insulating pattern to cover any one of the signal lines, wherein a portion of

the dummy insulating pattern is formed on the seal line area.

8. The method according to claim 7, wherein the organic electro-luminescence array includes an insulating film defining the light-emitting area by partially exposing the first electrode, and the dummy insulating pattern is simultaneously formed of the same material as the insulating film.

5

10

15

20

25

30

35

40

45

50

55

FIG. 1  
RELATED ART

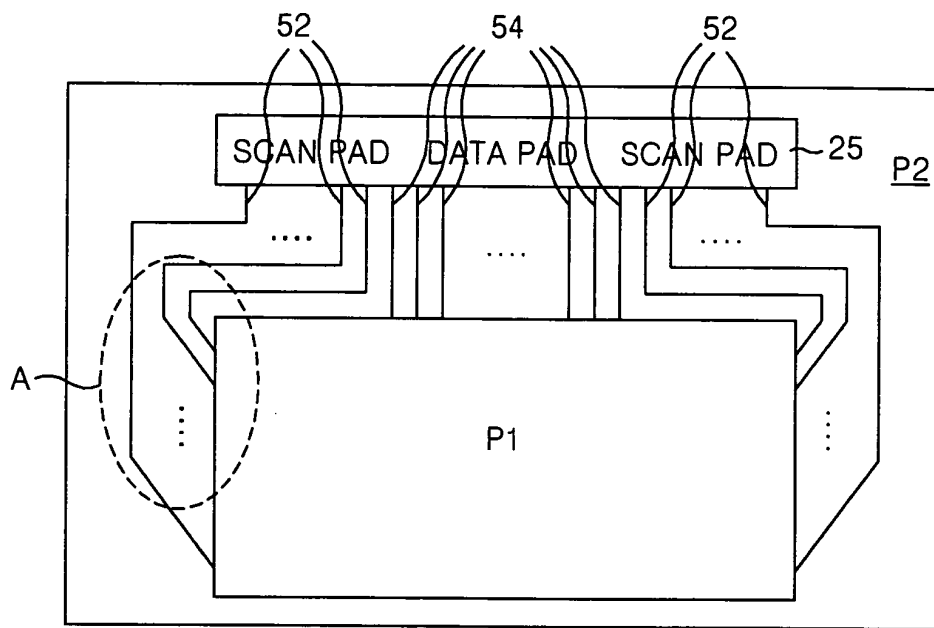

FIG. 2  
RELATED ART

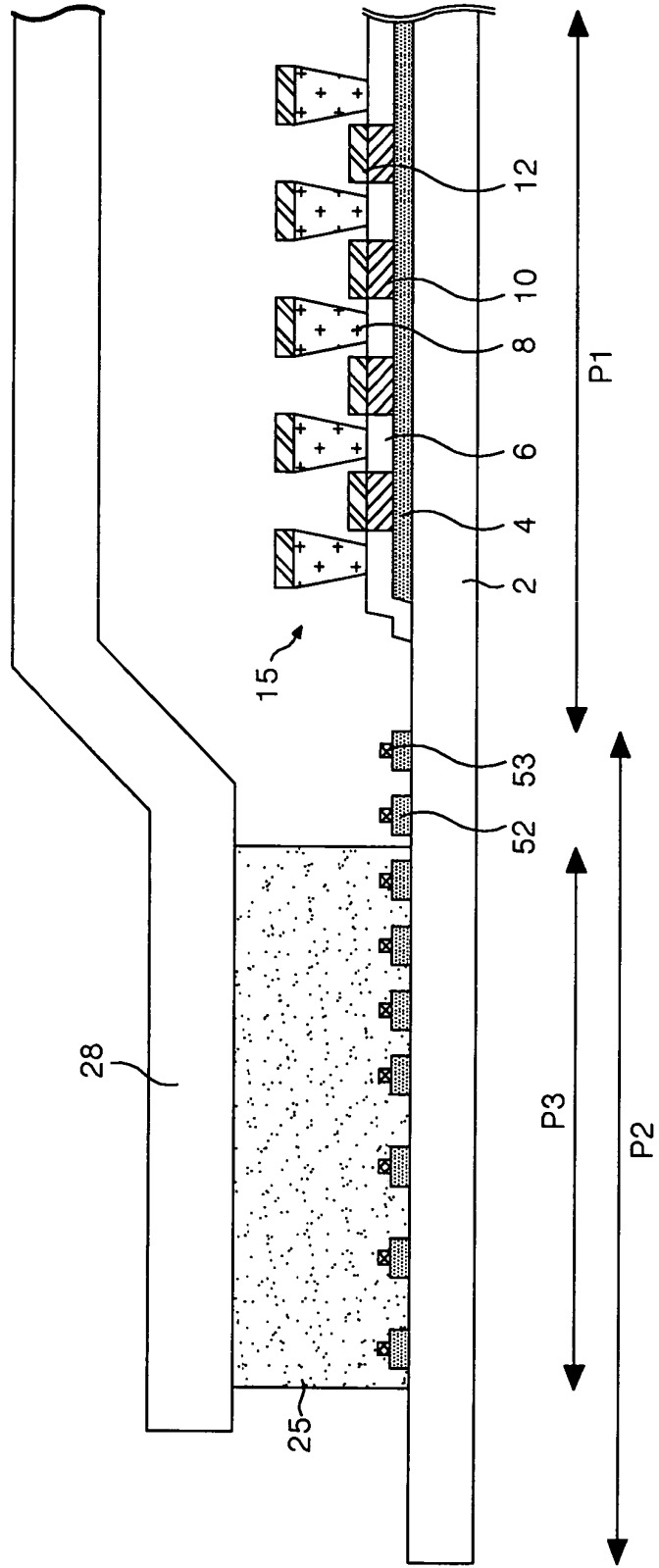

FIG.3  
RELATED ART

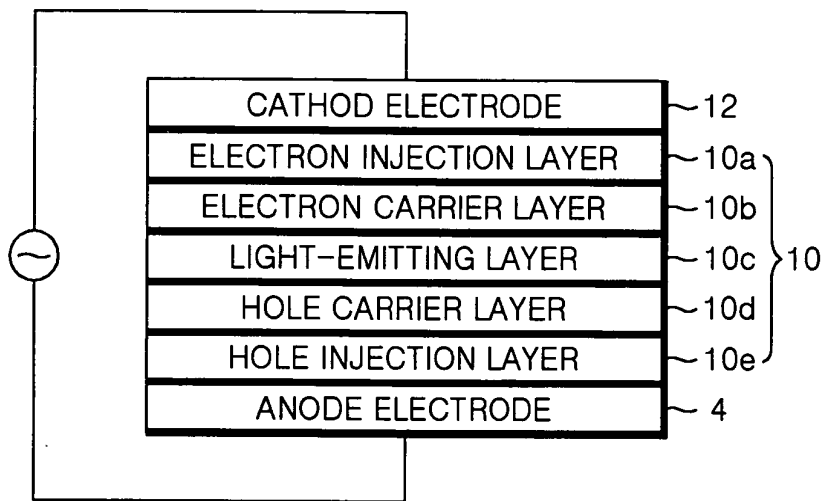

FIG. 4  
RELATED ART

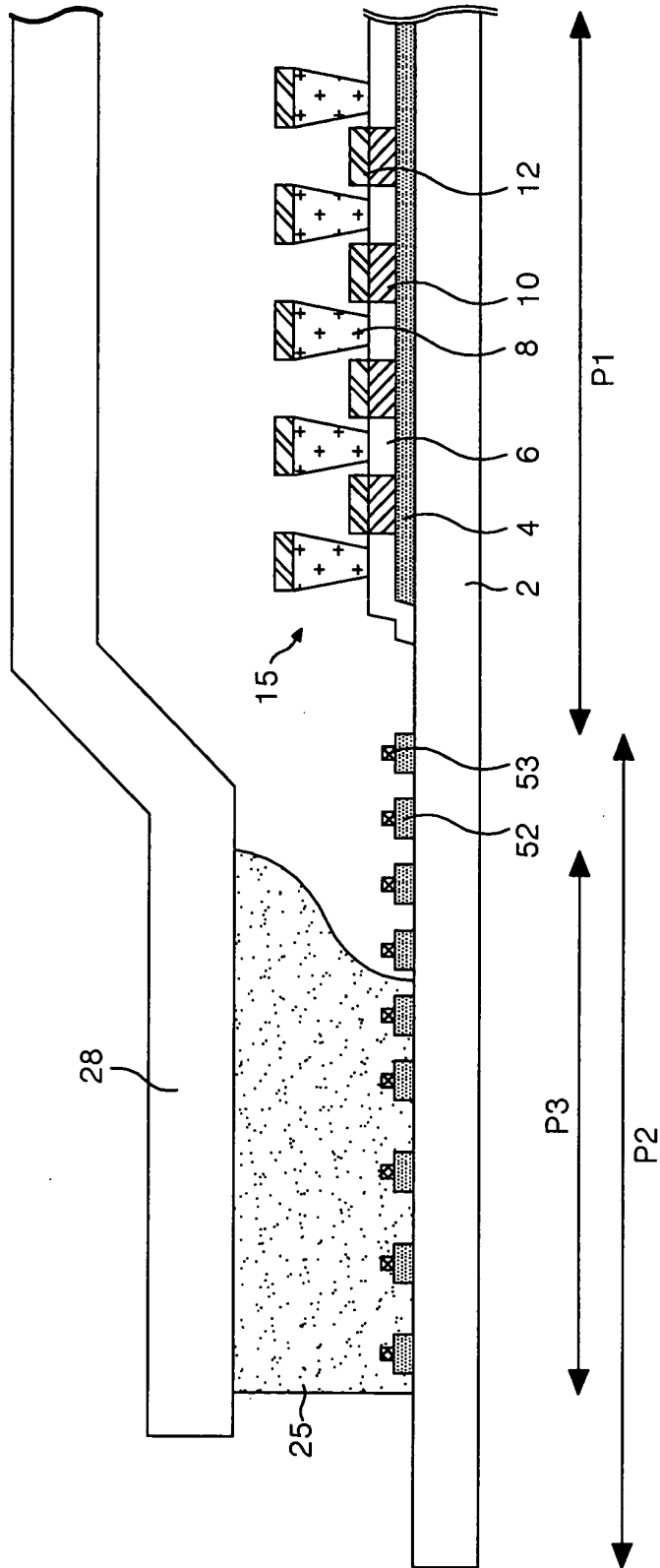

FIG. 5

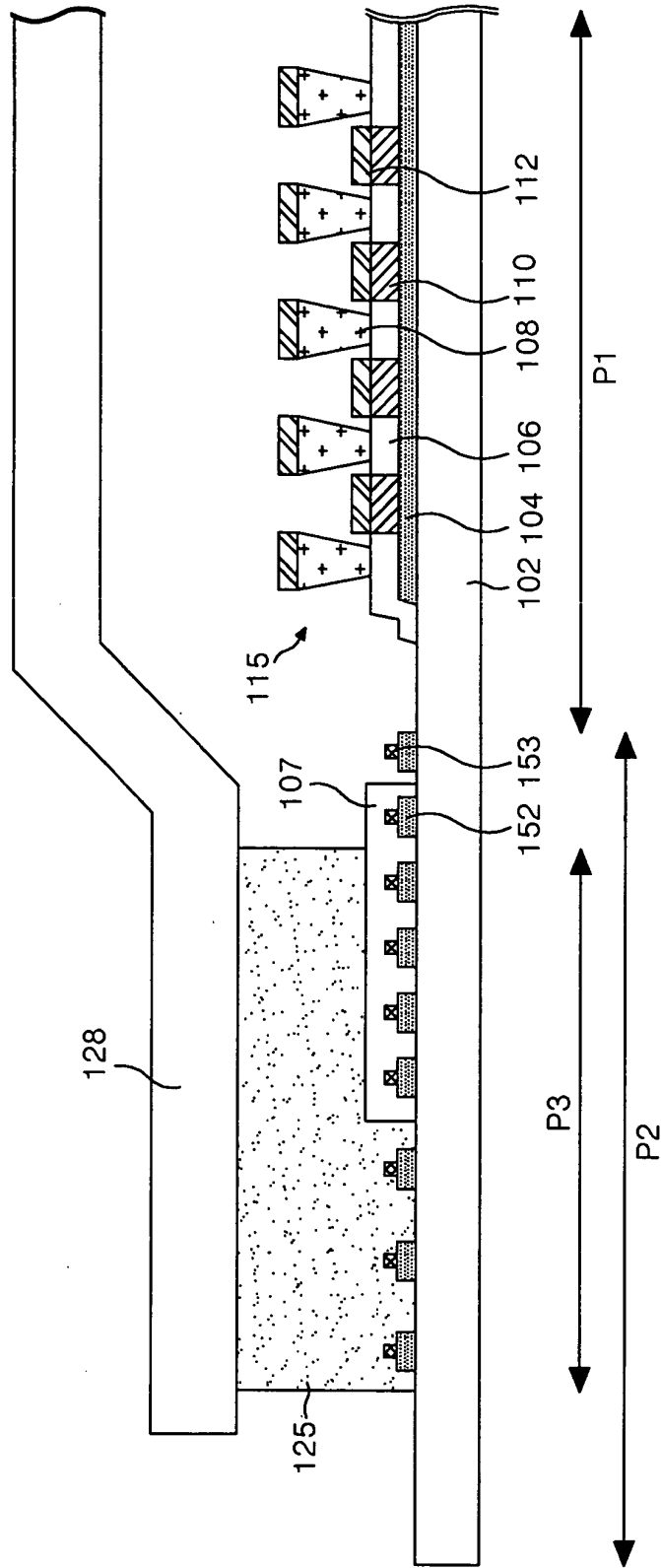

FIG. 6A

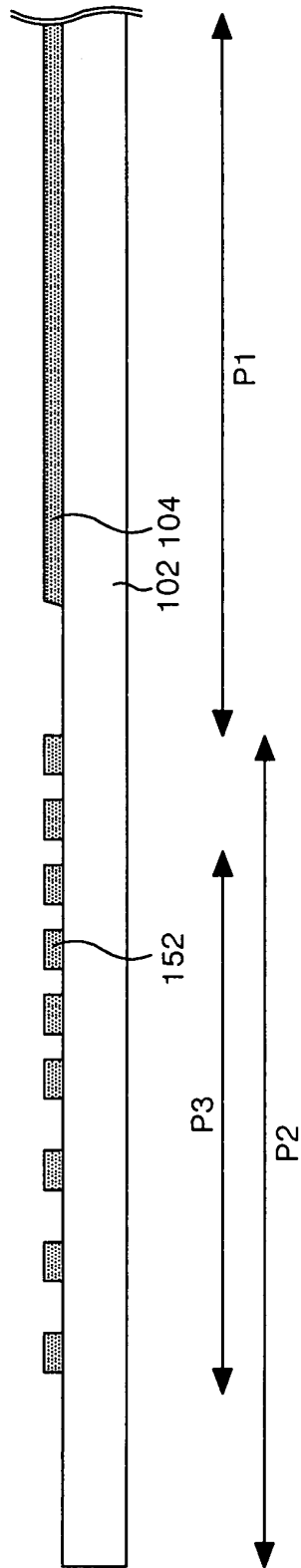

FIG. 6B

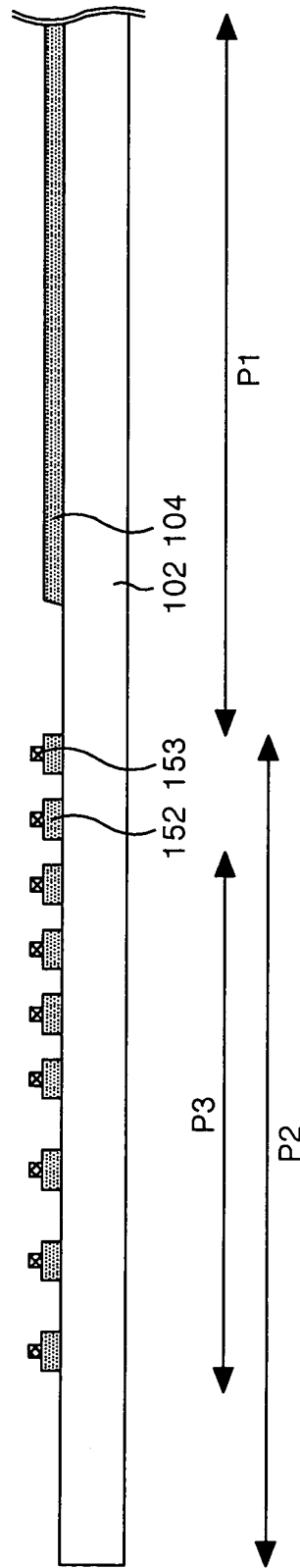

FIG. 6C

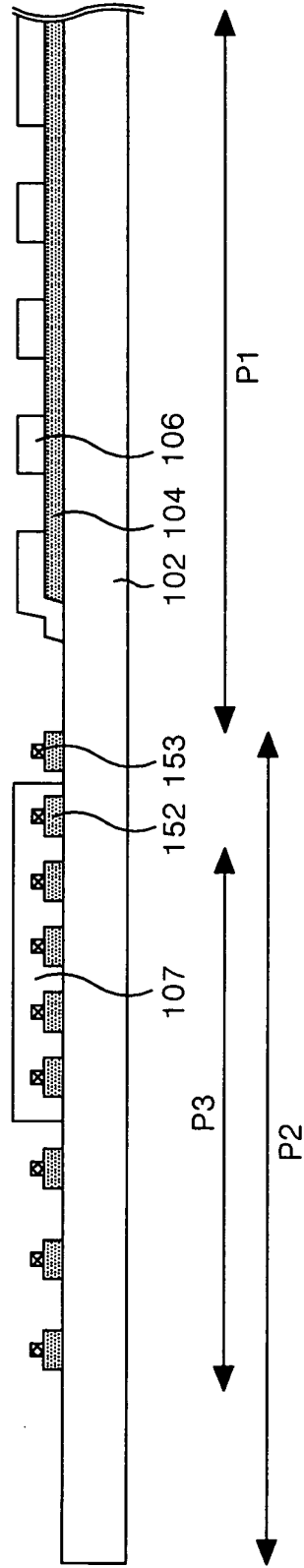

FIG. 6D

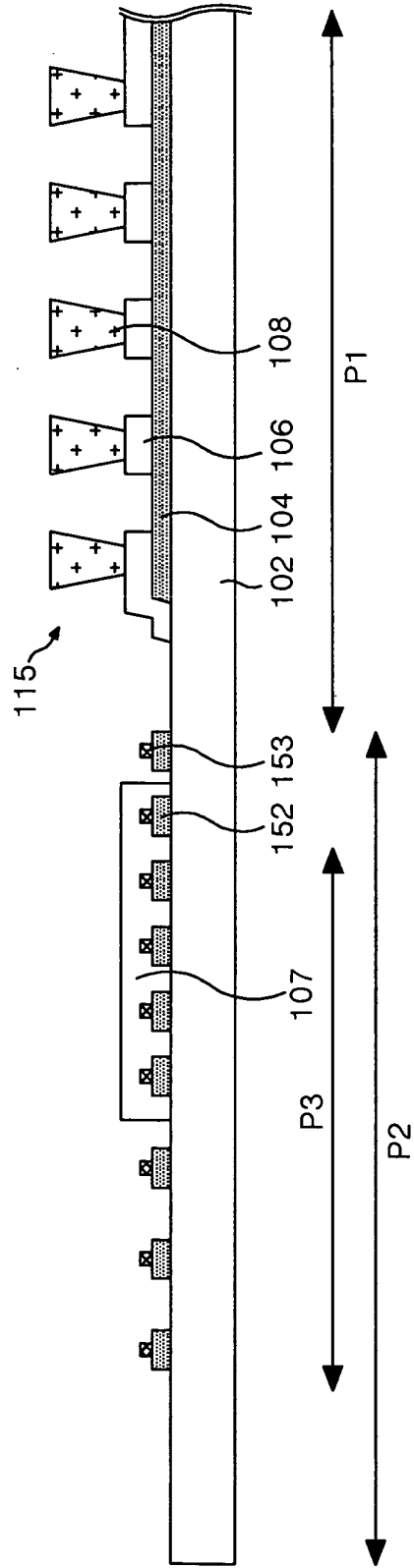

FIG. 6E

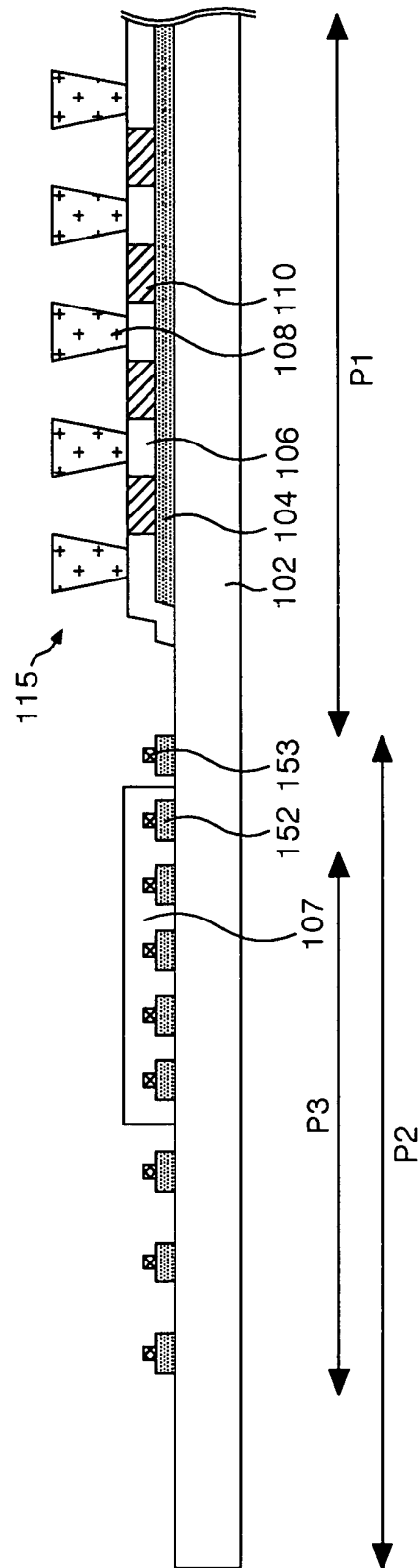

FIG. 6F

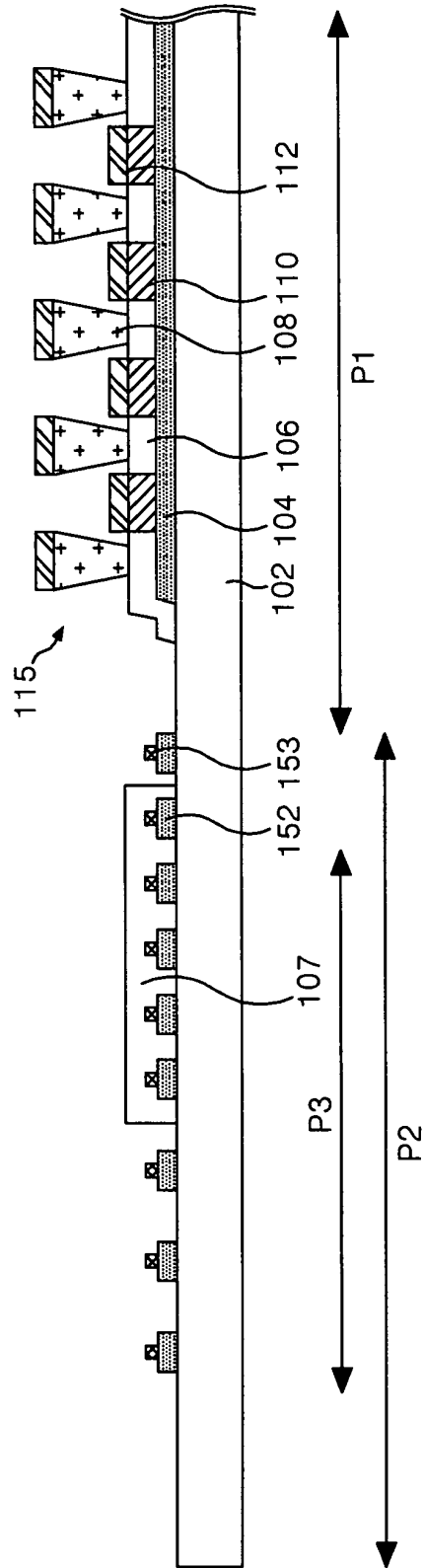
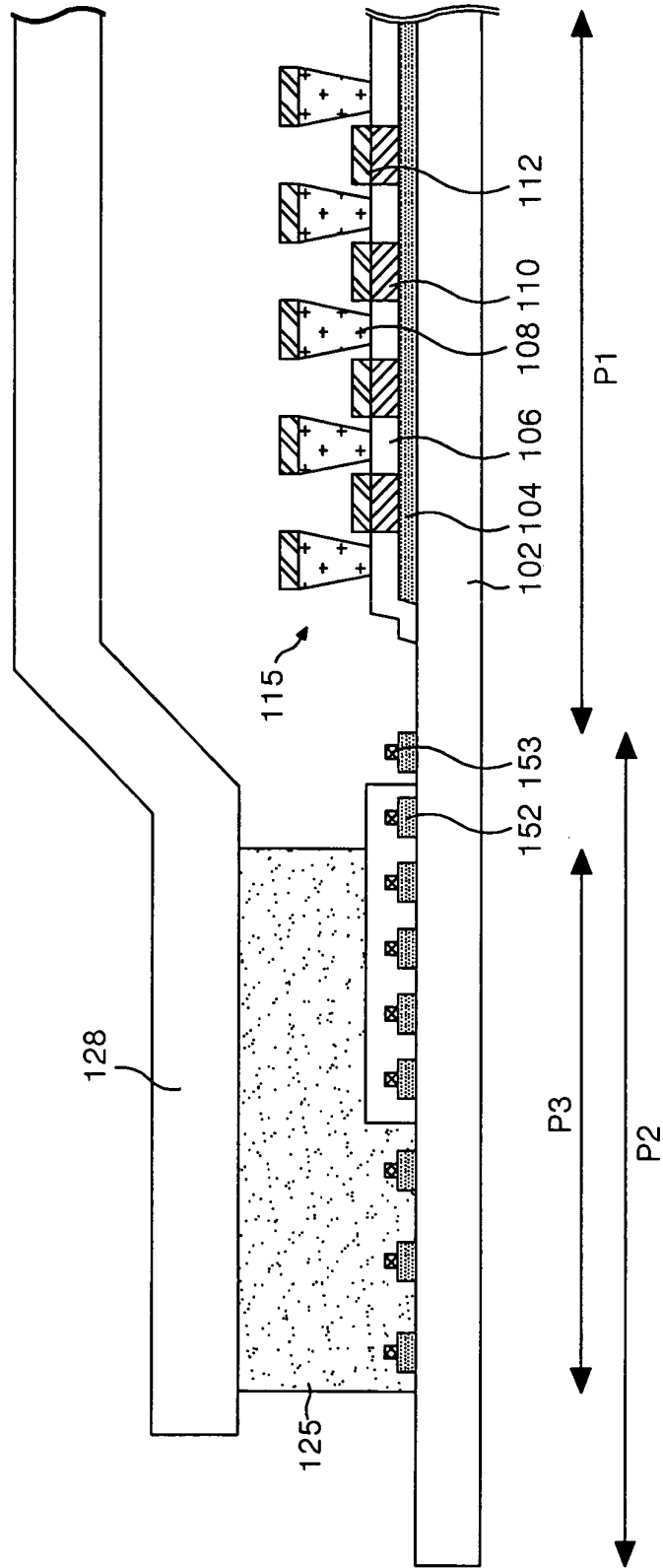

FIG. 6G



专利名称(译)	有机电致发光显示装置及其制造方法		
公开(公告)号	<a href="#">EP1608032A2</a>	公开(公告)日	2005-12-21
申请号	EP2005012738	申请日	2005-06-14
申请(专利权)人(译)	LG电子株式会社.		
当前申请(专利权)人(译)	LG电子株式会社.		
[标]发明人	PARK CHONG HYUN		
发明人	PARK, CHONG HYUN		
IPC分类号	H01L51/52 H05B33/04 H01L27/32 H01L51/20 H01L27/00		
CPC分类号	H01L51/5246 H01L27/3223 H01L27/3288		
优先权	1020040044331 2004-06-16 KR		
其他公开文献	EP1608032B1 EP1608032A3		
外部链接	<a href="#">Espacenet</a>		

摘要(译)

有机电致发光显示装置及其制造方法本发明涉及一种有机电致发光显示装置及其制造方法，其适用于改善封装过程中使用的密封剂的粘附性。根据本发明的有机电致发光显示装置包括：基板，其设置有有机电致发光阵列，所述有机电致发光阵列具有彼此交叉的第一和第二电极，其间具有有机发光层；盖子通过密封剂粘附到密封线区域；多条信号线，连接到第一和第二电极中的任何一个并位于密封线区域上；形成覆盖任何一条信号线的虚设绝缘图案，其中虚设绝缘图案的一部分形成在密封线区域上。

