



(11) **EP 2 282 307 A1**

(12) **EUROPEAN PATENT APPLICATION**

(43) Date of publication:
09.02.2011 Bulletin 2011/06

(51) Int Cl.:
G09G 3/32^(2006.01)

(21) Application number: **10155924.3**

(22) Date of filing: **09.03.2010**

(84) Designated Contracting States:
**AT BE BG CH CY CZ DE DK EE ES FI FR GB GR
HR HU IE IS IT LI LT LU LV MC MK MT NL NO PL
PT RO SE SI SK SM TR**
Designated Extension States:
AL BA ME RS

(72) Inventor: **Kawashima, Shingo**
Chungcheongnam-do (KR)

(74) Representative: **Gulde Hengelhaupt Ziebig &
Schneider**
Patentanwälte - Rechtsanwälte
Wallstrasse 58/59
10179 Berlin (DE)

(30) Priority: **30.07.2009 KR 20090069925**

(71) Applicant: **Samsung Mobile Display Co., Ltd.**
Yongin-City
Gyeonggi-do (KR)

(54) **Organic light emitting display device and driving voltage setting method thereof**

(57) An organic light emitting display device with reduce power consumption is disclosed. Some embodiments include a current detector which measures current over varying drive voltages. The current measurements

are used to determine drive voltages for driving the display array.

EP 2 282 307 A1

Description

BACKGROUND

Field

[0001] The field relates to an organic light emitting display device and a method of setting a driving voltage thereof, and more particularly, to an organic light emitting display device and method resulting in reduced power.

Description of the Related Technology

[0002] Various flat panel display devices that have light weight and small volume when compared to a cathode ray tube have been developed. Among the flat panel display devices, an organic light emitting display device, which uses an organic compound as light emitting material, has various advantages in view of brightness and color purity so that it has been viewed as a next generation display device.

[0003] The organic light emitting display device as described above is coupled between supply lines of high power voltage and low power voltage and use organic light emitting diodes OLED emitting light of a brightness corresponding to data signals to display an image.

[0004] In order to allow the organic light emitting diodes to emit light uniformly during the emission periods of each frame, the voltage difference between the high power voltage and the low power voltage, that is, a driving voltage, should be sufficiently stable.

[0005] To this end, in the general organic light emitting display device, the driving voltage is set, having a voltage margin of about 30%, so that the sufficient driving voltage is determined based on the fluctuation in the driving voltage by the temperature characteristics of the organic light emitting diodes themselves and on the deviation in the driving voltage according to the emission colors.

[0006] However, the organic light emitting display device is typically operated according to an assumed condition. Therefore, the conventional voltage margin set by considering all conditions including even unnecessary conditions leads to unnecessary power consumption, thereby causing an unnecessary increase in power consumption.

SUMMARY OF CERTAIN INVENTIVE ASPECTS

[0007] A first aspect of the invention provides a driving method for an organic light emitting display device as set forth in claim 1. A second aspect of the invention provides an organic light emitting display device carrying out the driving method of the first inventive aspect. Preferred embodiments are subject of the dependent claims.

BRIEF DESCRIPTION OF THE DRAWINGS

[0008] The accompanying drawings, together with the

written description illustrate exemplary embodiments.

[0009] FIG. 1 is a circuit view showing one example of a pixel according to some embodiments;

[0010] FIG. 2 is a graph showing a panel current according to a driving voltage of a panel;

[0011] FIG. 3 is a block diagram showing an organic light emitting display device according to some embodiments; and

[0012] FIG. 4 is a block diagram showing an example of the current detector of FIG. 3.

DETAILED DESCRIPTION OF CERTAIN INVENTIVE EMBODIMENTS

[0013] Hereinafter, certain exemplary embodiments will be described with reference to the accompanying drawings. Herein, when a first element is described as being coupled to a second element, the first element may be directly coupled to the second element or may be indirectly coupled to the second element via a third element. Further, some of the elements that are not essential to the complete understanding of the invention are omitted for clarity. Also, like reference numerals generally refer to like elements throughout.

[0014] Hereinafter, exemplary embodiments will be described with reference to the accompanying drawings.

[0015] FIG. 1 is a circuit view showing one example of a pixel according to some embodiments. For convenience of explanation, a pixel of an active type organic light emitting display device having a simple structure will be exemplified in FIG. 1.

[0016] Referring to FIG. 1, the pixel 10 includes an organic light emitting diode OLED coupled between a supply line of first power voltage ELVDD and a supply line of second power supply ELVSS and a pixel circuit 12 that controls the organic light emitting diode OLED.

[0017] In this embodiment, the anode electrode of the organic light emitting diode OLED is coupled to the supply line of the first power supply ELVDD via the pixel circuit 12 and the cathode electrode thereof is coupled to the supply line of the second power supply ELVSS. Herein, the first power voltage ELVDD is a high power voltage and the second power voltage ELVSS is a low power voltage lower than the first power voltage ELVDD.

[0018] The organic light emitting diode OLED as described above emits light at a brightness corresponding to the driving current supplied from the pixel circuit 12.

[0019] The pixel circuit 12 includes a first transistor M1, a second transistor M2, and a capacitor C1.

[0020] The first transistor M1 is coupled between a data line Dm and a first node N1, wherein the gate electrode of the first transistor M1 is coupled to a scan line Sn. When a scan signal is supplied from the scan line Sn, the first transistor M1 is turned on to transfer the data signal from the data line Dm to the first node N1.

[0021] The second transistor M2 is coupled between the supply line of the first power voltage ELVDD and the organic light emitting diode OLED, wherein the gate elec-

trode of the second transistor M2 is coupled to the first node N1. The second transistor M2 as described above supplies the driving current corresponding to the voltage Vgs between the source electrode and the gate electrode thereof to the organic light emitting diode OLED.

[0022] The capacitor Cst is coupled between the first node N1 and the supply line of the first power voltage ELVDD. In other words, the capacitor Cst is coupled between the source electrode and the gate electrode of the second transistor M2. When the scan signal is supplied from the scan line Sn, the capacitor Cst is charged with the voltage corresponding to the data signal at the first node N1 to store it for one frame.

[0023] When the scan signal is supplied from the scan line Sn, the first transistor M1 is turned on and the data signal is transferred to the first node N1 from the data line Dm. At this time, the capacitor Cst is charged with the voltage corresponding to the difference between the data signal and the first power voltage ELVDD to store it until the data signal of the next frame is supplied.

[0024] The second transistor M2 acts as a constant current source supplying current corresponding to the data signal to the organic light emitting diode OLED, according to the voltage Vgs between the gate electrode and the source electrode thereof as maintained by the capacitor Cst. Accordingly, the organic light emitting diode OLED emits light at the brightness corresponding to the data signal.

[0025] In order that the organic light emitting diode OLED uniformly emits light according to the data signal during the emission periods of the respective frames, the second transistor M2 is to be a stable constant current source during the emission period of each frame.

[0026] To this end, not only the voltage Vgs between the gate electrode and the source electrode of the second transistor M2 but also the voltage Vds between the source electrode and the drain electrode are to be stable. Therefore, the voltage difference between the high power voltage and the low power voltage, that is, the driving voltage, is to be stable from frame to frame while the panel is driven.

[0027] For a given Vgs, a driving voltage, or Vds can be selected for stable, power efficient operation. A driving voltage which is too low causes high dependence of the driving current on the Vds. That is, for a small change in Vds a large current change occurs. This results in undesired brightness variation. A driving voltage which is too high results in unnecessarily high power consumption. Therefore, some embodiments include a method to reduce power consumption by setting a driving voltage that results in low power driving current which is substantially independent of variation in Vds. The detailed description thereof will be described below.

[0028] FIG. 2 is a graph showing a panel current according to a driving voltage of a panel. In FIG. 2, the driving voltage of the panel is the voltage difference between the first power voltage ELVDD and the second power voltage ELVSS and the panel current represents

the total amount of current flowing through the panel light emitting diodes.

[0029] Referring to FIG. 2, for low driving voltages, as the driving voltage of the panel is increased, the amount of current flowing on the panel is also increased. However, in the voltage region greater than a certain driving voltage, the current is substantially constant.

[0030] An optimal driving voltage can reduce unnecessary voltage margin, while securing substantially constant current of the driving transistor. In some embodiments, an optimal driving voltage may be selected as the voltage at which the slope of the current vs. driving voltage curve is less than a threshold. The optimal driving voltage may be used as the driving voltage that drives the organic light emitting display device.

[0031] In some embodiments, an optimal driving voltage may be obtained by detecting the driving voltage at the current at a turning point where the derivatives of the panel current according to the driving voltage is changed.

[0032] In some embodiments, the optimal driving voltage for each of the respective emission colors is different. In such embodiments, the highest of the optimal driving voltages may be selected as a single optimal driving voltage for all colors.

[0033] In FIG. 2, the points marked with stars are the points where the respective emission colors emit light at desired brightness (for example, brightness of 350cd/m²), the driving voltage at A may be selected as the optimal driving voltage. In this case, the unnecessary power consumption due to the unnecessary voltage margin of approximately 30% of the driving voltage at B is not necessary.

[0034] As a result, low voltage can be used for low power, while still achieving substantially constant current. Beneficially, the value of A may be determined while operating the display. The detailed description thereof will be described later with reference to FIGS. 3 and 4.

[0035] FIG. 3 is a block diagram showing an organic light emitting display device according to some embodiments, and FIG. 4 is a block diagram showing an example of the current detector of FIG. 3.

[0036] Referring to FIG. 3, the organic light emitting display device includes a display panel 100 that display an image, a power supplier 110 that supplies a driving voltage to the display panel 100, and a current detector 120 that detects a panel current flowing into the display panel 100 according to the driving voltage.

[0037] The display panel 100 may be implemented as an active type organic light emitting display panel that includes pixels as shown in FIG. 1 or active type pixels having a pixel structure that is variously modified, or a passive type organic light emitting display panel that does not include active elements in the pixel. Also, the display panel 100 may further include a driving circuit such as a scan driver and/or a data driver, etc., according to the design scheme thereof.

[0038] The display panel 100 as described above is turned on by the driving voltage supplied from the power

supplier 110, to display an image corresponding to a data signal.

[0039] The power supplier 110 supplies the driving voltage to the display panel 100. More specifically, the power supplier 110 outputs a first power voltage ELVDD to a positive output terminal and outputs a second power voltage ELVSS to a negative output terminal. Accordingly, the display panel 100 is driven by the driving voltage, which is the voltage difference between the first power voltage ELVDD and the second power voltage ELVSS.

[0040] In some embodiments, the power supplier 110 includes a variable circuit (not shown) that varies the driving voltage so that the optimal driving voltage is used. For example, the power supplier 110 may include a variable circuit that varies the driving voltage by varying the first power voltage ELVDD.

[0041] The current detector 120 detects a panel current flowing into the display panel 100 while the driving voltage is supplied from the power supplier 110 to the display panel 100. For example, the current detector 120 is positioned on the first power supply line that transfers the first power voltage ELVDD from the power supplier 110 to the display panel 100 to measure the current flowing in the first power supply line, thereby making it possible to detect the panel current flowing into the display panel 100.

[0042] The current detector 120 calculates the variations of the panel current according to the driving voltage, thereby allowing the optimal driving voltage as shown in the time point A in FIG. 2 to be selected.

[0043] As shown in FIG. 4, the current detector 120 may include a current sensor 122 that detects the panel current I_{panel} flowing to the display panel and a variation calculator 124 that calculates the variations of the panel current. Also, the current detector 120 may further include a control signal generator 126 that controls the power supplier 110 based on the variations dI_{panel} of the panel current calculated by the variation calculator 124.

[0044] Accordingly, the current sensor 122 detects the panel current I_{panel} flowing to the display panel while the driving voltage is supplied to the display panel 100. A signal based on the panel current I_{panel} detected from the current sensor 122 is input to the variation calculator 124.

[0045] The variation calculator 124 calculates the variations of the panel current according to the driving voltage. The derivatives of the panel current may be calculated. Accordingly, the variation calculator 124 may output the derivative of the panel current according to the driving voltage and may, for example, be an analog differentiator. The information on the variations of the panel current calculated from the variation calculator 124 is input into the control signal generator 126.

[0046] The control signal generator 126 generates a control signal CS that controls the power supplier 110 according to the variations of the panel current. For example, the control signal generator 126 may generate a

control signal so that the power supplier 110 generates a driving voltage substantially equal to the lowest driving voltage where the derivative of the panel current according to the driving voltage is less than a threshold.

[0047] In some embodiments, the control signal generator 126 is included in the current detector 120, but the control signal generator 126 may be separate from the current detector 120 or may also be in an output voltage setting block in the power supplier 110.

[0048] The organic light emitting display device according to some embodiments varies the driving voltage output into the display panel 100 from the power supplier 110 to detect the panel current I_{panel} flowing into the display panel 100 and to calculate the variations of the panel current according to the driving voltage, in order to set an optimal driving voltage.

[0049] A method of setting a driving voltage for an organic light emitting display device according to some embodiments includes varying a driving voltage in a power supplier 110 and supplying it to a display panel 100, detecting a panel current I_{panel} flowing into the display panel 100 during a period when the driving voltage is varied and supplied, and calculating the variations of the panel current according to the driving voltage and setting an optimal driving voltage based on the variations.

[0050] An optimal driving voltage may be set as the driving voltage at the point where the driving voltage at a turning point where the derivatives of the panel current according to the driving voltage is changed. (e.g. the driving voltage at the point where the derivative of the panel current is reduced as the driving voltage is increased).

[0051] In some embodiments, the display panel 100 displays an image while the current and driving voltage data is taken.

[0052] In some embodiments, the display panel 100 displays an image of maximum luminance while the current and driving voltage data is taken. However, the embodiment is not limited thereto. The data can be taken while a still screen is displayed. The display panel does not always set the optimal driving voltage while displaying a full-white screen. For example, after detecting the optimal driving voltage for each emission color, the driving voltage to drive the organic light emitting display device may be finally determined based thereon. Also, in the case of the passive type organic light emitting display device, after detecting the optimal driving voltage for each emission color, the driving voltage optimized for each emission color may be applied at the time of driving.

[0053] Moreover, if the optimal driving voltage is set in the manner as described above under a condition matching the environment where the organic light emitting display device is to be driven, the constant current may be flowed to the panel during the light emitting period of the respective frames, while preventing the voltage margin from being set in consideration of all of unnecessary conditions. Therefore, the unnecessary voltage margin is minimized, making it possible to reduce the power consumption.

[0054] In addition, in some embodiments, the display sets the optimal driving voltage in consideration of the environment to be driven before it comes to the market or it can also be variously designed so that the optimal driving voltage is changed and set according to the change in the environment during the use thereof.

Claims

1. A method of setting a driving voltage for an organic light emitting display device, the method comprising:
 - sequentially supplying a plurality of different driving voltages to a display panel;
 - detecting a panel current flowing into the display panel for each of the plurality of different driving voltages;
 - calculating variations of the panel current resulting from the plurality of different driving voltages; and
 - determining an optimal driving voltage based on the variations of the panel current.
2. The method as claimed in claim 1, wherein the optimal driving voltage is determined as a driving voltage at a point where the derivative of the panel current with respect to the driving voltage changes.
3. The method as claimed in one of the claims 1 or 2, wherein the optimal driving voltage is determined as a driving voltage at a point where the derivative of the panel current with respect to the driving voltage is reduced below a threshold.
4. The method as claimed in one of the preceding claims, wherein the display panel displays a still image while panel current data for calculating the variations of the panel current is detected.
5. The method as claimed in claim 4, wherein the display panel is supplied with image data corresponding to a maximum gray scale while the panel current data for calculating the variations of the panel current is detected.
6. The method as claimed in one of the preceding claims, wherein the optimal driving voltage is determined by selecting the greatest of multiple driving voltages, each of the multiple driving voltages being determined as an optimal driving voltage for one of a plurality of colours of organic light emitting diodes included in the organic light emitting display device.
7. An organic light emitting display device, comprising:
 - a display panel comprising a plurality of organic light emitting of at least one colour;
8. The organic light emitting display device as claimed in claims 7, wherein the power supplier is configured to output a first power voltage to a positive output terminal and a second power voltage to a negative output terminal, and the driving voltage is a voltage difference between the first power voltage and the second power voltage.
9. The organic light emitting display device as claimed in claim 8, wherein the first power voltage is a high power voltage and the second power voltage is a low power voltage.
10. The organic light emitting display device as claimed in claim 9, wherein the power supplier is configured to vary the driving voltage by varying the first power voltage.
11. The organic light emitting display device as claimed in one of the claims 8 through 10, wherein the current detector is connected to a first power supply line connected to the positive output terminal and to the display panel and is configured to detect the panel current flowing in the first power supply line.
12. The organic light emitting display device as claimed in one of the claims 7 through 11. wherein the current detector includes:
 - a current sensor adapted to detect the panel current; and
 - a variation calculator adapted to calculate the variations of the panel current.
13. The organic light emitting display device as claimed in claim 12, wherein the variation calculator is adapted to output the derivative of the panel current with respect to the driving voltage.
14. The organic light emitting display device as claimed in claim 13, wherein the variation calculator comprises an analog differentiator adapted to output the derivative of the panel current with respect to the driving voltage.
15. The organic light emitting display device as claimed in one of the claims 7 through 14, wherein the con-

a power supplier configured to supply a variable driving voltage to the display panel, the variable driving voltage having a voltage value determined by a driving voltage control signal;

a current detector configured to detect a panel current flowing from the power supplier into the display panel; and

a controller connected to the power supplier and the current detector and adapted to carry out the method of one of the preceding claims.

troller further includes a control signal generator adapted to generate a control signal for controlling the power supplier.

5

10

15

20

25

30

35

40

45

50

55

6

FIG. 1

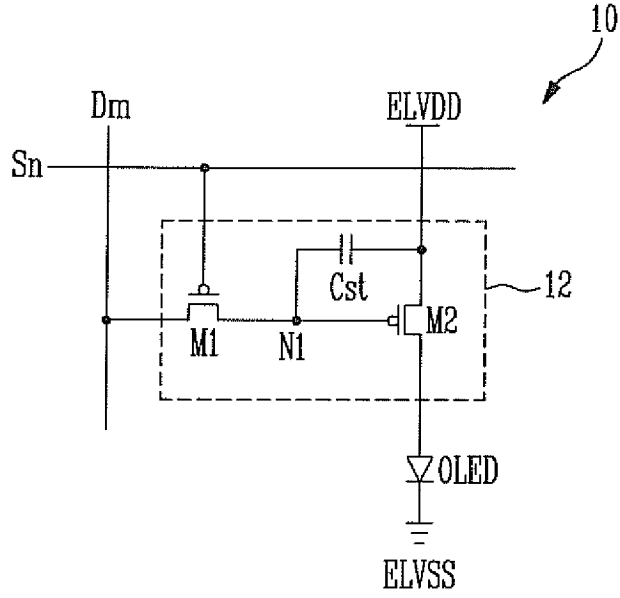

FIG. 2

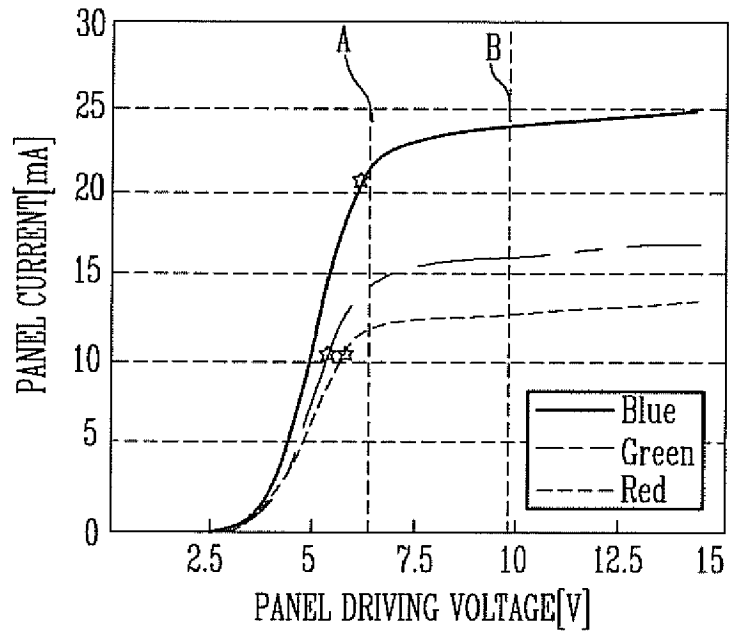

FIG. 3

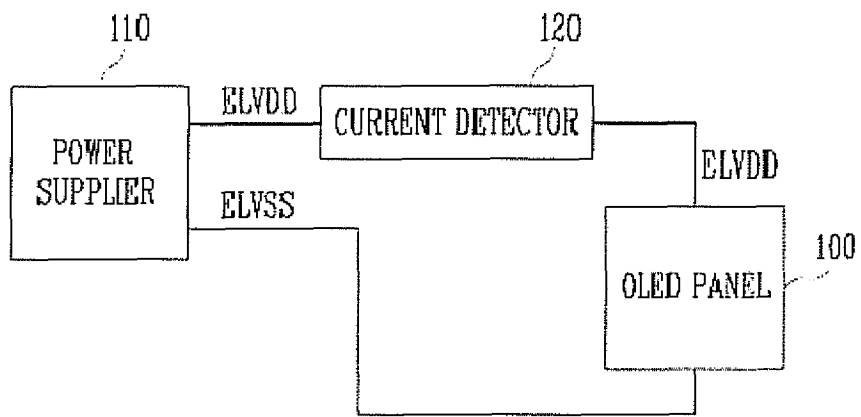
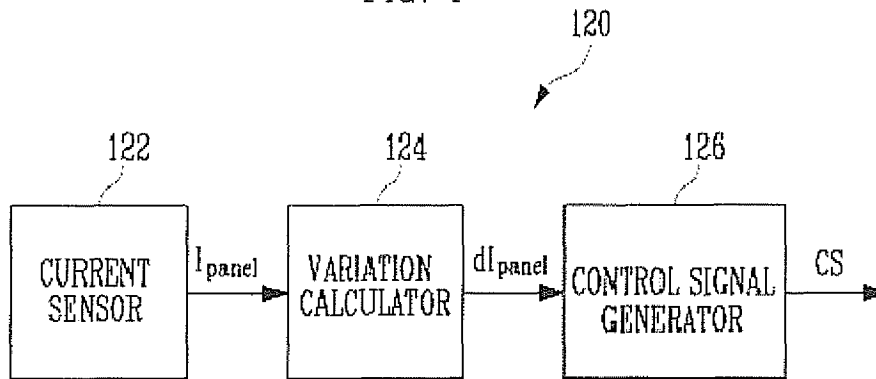

FIG. 4





EUROPEAN SEARCH REPORT

Application Number
EP 10 15 5924

DOCUMENTS CONSIDERED TO BE RELEVANT			
Category	Citation of document with indication, where appropriate, of relevant passages	Relevant to claim	CLASSIFICATION OF THE APPLICATION (IPC)
X	GB 2 430 069 A (CAMBRIDGE DISPLAY TECH [GB]) 14 March 2007 (2007-03-14) * figures 3,4 * * page 4 - page 8 * * page 10 - page 11 * -----	1-15	INV. G09G3/32
A	US 2004/263444 A1 (KIMURA HAJIME [JP]) 30 December 2004 (2004-12-30) * figures 1,5,6,8 * -----	1-15	
A	EP 0 923 067 A1 (SEIKO EPSON CORP [JP]) 16 June 1999 (1999-06-16) * figure 3 * -----	1-15	
			TECHNICAL FIELDS SEARCHED (IPC)
			G09G
The present search report has been drawn up for all claims			
Place of search		Date of completion of the search	Examiner
The Hague		28 April 2010	Husselin, Stephane
<p>CATEGORY OF CITED DOCUMENTS</p> <p>X : particularly relevant if taken alone Y : particularly relevant if combined with another document of the same category A : technological background O : non-written disclosure P : intermediate document</p> <p>T : theory or principle underlying the invention E : earlier patent document, but published on, or after the filing date D : document cited in the application L : document cited for other reasons & : member of the same patent family, corresponding document</p>			

2
EPO FORM 1503 03.02 (P04C01)

**ANNEX TO THE EUROPEAN SEARCH REPORT
ON EUROPEAN PATENT APPLICATION NO.**

EP 10 15 5924

This annex lists the patent family members relating to the patent documents cited in the above-mentioned European search report. The members are as contained in the European Patent Office EDP file on The European Patent Office is in no way liable for these particulars which are merely given for the purpose of information.

28-04-2010

Patent document cited in search report	Publication date	Patent family member(s)	Publication date
GB 2430069	A	14-03-2007	CN 101263543 A 10-09-2008
			DE 112006002427 T5 26-06-2008
			GB 2443372 A 30-04-2008
			WO 2007031704 A1 22-03-2007
			JP 2009508171 T 26-02-2009
			KR 20080045192 A 22-05-2008
			US 2009201281 A1 13-08-2009

US 2004263444	A1	30-12-2004	NONE

EP 0923067	A1	16-06-1999	DE 69825402 D1 09-09-2004
			DE 69825402 T2 04-08-2005
			WO 9840871 A1 17-09-1998
			JP 3887826 B2 28-02-2007
			KR 20000010923 A 25-02-2000
			TW 397965 B 11-07-2000
			US 2002180721 A1 05-12-2002

专利名称(译)	有机发光显示装置及其驱动电压设定方法		
公开(公告)号	EP2282307A1	公开(公告)日	2011-02-09
申请号	EP2010155924	申请日	2010-03-09
[标]申请(专利权)人(译)	三星显示有限公司		
申请(专利权)人(译)	三星移动显示器有限公司.		
当前申请(专利权)人(译)	三星DISPLAY CO. , LTD.		
[标]发明人	KAWASHIMA SHINGO		
发明人	KAWASHIMA, SHINGO		
IPC分类号	G09G3/32		
CPC分类号	G09G3/3233 G09G2300/0842 G09G2320/029 G09G2320/043 G09G2330/021		
优先权	1020090069925 2009-07-30 KR		
其他公开文献	EP2282307B1		
外部链接	Espacenet		

摘要(译)

公开了一种降低功耗的有机发光显示装置。一些实施例包括电流检测器，其测量变化的驱动电压上的电流。电流测量值用于确定驱动显示阵列的驱动电压。

