



(11) **EP 3 550 608 A1**

(12) **EUROPEAN PATENT APPLICATION**
published in accordance with Art. 153(4) EPC

(43) Date of publication:
09.10.2019 Bulletin 2019/41

(51) Int Cl.:
H01L 27/32^(2006.01) H01L 51/52^(2006.01)
H01L 51/56^(2006.01)

(21) Application number: **17829908.7**

(86) International application number:
PCT/CN2017/091189

(22) Date of filing: **30.06.2017**

(87) International publication number:
WO 2018/099072 (07.06.2018 Gazette 2018/23)

(84) Designated Contracting States:
AL AT BE BG CH CY CZ DE DK EE ES FI FR GB GR HR HU IE IS IT LI LT LU LV MC MK MT NL NO PL PT RO RS SE SI SK SM TR
Designated Extension States:
BA ME
Designated Validation States:
MA MD

(72) Inventors:
• **FAN, Xing**
Beijing 100176 (CN)
• **YAN, Guang**
Beijing 100176 (CN)

(30) Priority: **01.12.2016 CN 201611091447**

(74) Representative: **Brötz, Helmut et al**
Rieder & Partner mbB
Patentanwälte - Rechtsanwalt
Corneliusstrasse 45
42329 Wuppertal (DE)

(71) Applicant: **BOE Technology Group Co., Ltd.**
Beijing 100015 (CN)

(54) **ORGANIC ELECTROLUMINESCENT DISPLAY SUBSTRATE AND MANUFACTURING METHOD THEREFOR, DISPLAY PANEL AND DISPLAY DEVICE**

(57) An organic electroluminescence display substrate and a fabrication method thereof, a display panel and a display device are provided. The organic electroluminescence display substrate (10) includes a pixel array (100) and a light extraction layer (200). The pixel array (100) includes a plurality of pixels (110), each pixel (110) includes a first sub-pixel (120) emitting light of a first color, and each first sub-pixel (120) includes an organic electroluminescence element (150). The light extraction layer (100) covers on the pixel array (100), and at least includes a plurality of first light extraction units (211) and a plurality of second light extraction units (212) arranged in parallel

and having different optical properties. A cathode light-emission side of each first sub-pixel (120) is covered by at least one first light extraction unit (211) and at least one second light extraction unit (212), or the cathode light-emission sides of two adjacent first sub-pixels (120) are respectively covered by at least one first light extraction unit (211) and at least one second light extraction unit (212). By providing at least two light extraction units with optical properties different from each other, improvement of a luminance viewing angle characteristic and/or a chrominance viewing angle characteristic is implemented.

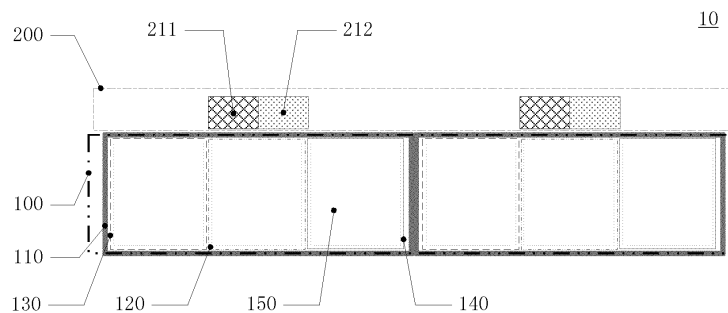

FIG. 1(a)

EP 3 550 608 A1

Description

TECHNICAL FIELD

5 **[0001]** Embodiments of the present disclosure relate to an organic electroluminescence display substrate, a display panel, a display device, and a fabrication method of the organic electroluminescence display substrate.

BACKGROUND

10 **[0002]** Due to advantages such as self-illumination, low power consumption, fast response, flexibility, high contrast, wide viewing angle, ultra-thinness, low cost and the like, an organic electroluminescence element is increasingly favored by people. For example, the organic electroluminescence element includes an anode, a cathode and an organic light emitting layer provided between the anode and the cathode, the anode is provided on a side close to a base substrate, and the cathode is provided on a side away from the base substrate.

15 **[0003]** According to a light emission direction, the organic electroluminescence element is divided into an organic electroluminescence element of a bottom-emission type, an organic electroluminescence element of a top-emission type and an organic electroluminescence element of a bilateral-emission type. The organic electroluminescence element of the bottom-emission type refers to an organic electroluminescence element whose light is emitted from the side of the base substrate (i.e., an anode emission side), the organic electroluminescence element of the top-emission type refers to an organic electroluminescence element whose light is emitted from the top of the element (i.e., a cathode emission side), and the light-emitting element of the bilateral-emission type refers to an organic electroluminescence element whose light is emitted simultaneously from the side of the base substrate and the top of the element (i.e., the anode emission side and the cathode emission side).

20 **[0004]** Due to a broad fluorescence spectra of an organic light emitting material, it is necessary to introduce an optical microcavity into the organic electroluminescence element, to narrow a full width at half maximum (FWHM) of the emission spectra by a microcavity resonance effect. However, due to a strong selective effect of the optical microcavity on a wavelength, luminance and color coordinates of the emission light of the organic electroluminescence element of the microcavity type change with a viewing angle, and thus a display effect is affected. Therefore, improving a luminance viewing angle characteristic and/or a chrominance viewing angle characteristic of the organic electroluminescence element is an urgent problem to be solved in a display field.

SUMMARY

35 **[0005]** The embodiments of the disclosure provide an organic electroluminescence display substrate. The organic electroluminescence display substrate comprises a pixel array and a light extraction layer. The pixel array includes a plurality of pixels arranged in an array, each of the pixels includes a first sub-pixel emitting light of a first color, and each of the first sub-pixels includes an organic electroluminescence element. The light extraction layer covers on the pixel array and at least includes a plurality of first light extraction units and a plurality of second light extraction units, and an optical property of the first light extraction unit and an optical property of the second light extraction unit are different from each other. Cathode light-emission sides of two adjacent first sub-pixels are covered by at least one of the first light extraction units and at least one of the second light extraction units.

40 **[0006]** The embodiments of the disclosure provide a display panel. The display panel comprises the organic electroluminescence display substrate as described above.

45 **[0007]** The embodiments of the disclosure provide a display device. The display device comprises the display substrate as described above or the display panel as described above.

50 **[0008]** The embodiments of the disclosure provide a fabrication method of an organic electroluminescence display substrate. The fabrication method comprises: forming a pixel array and forming a light extraction layer. The pixel array includes a plurality of pixels arranged in an array, each of the pixels includes a first sub-pixel emitting light of a first color, and each of the first sub-pixels includes an organic electroluminescence element. The light extraction layer covers on the pixel array and at least includes a plurality of first light extraction units and a plurality of second light extraction units, an optical property of the first light extraction unit and an optical property of the second light extraction unit are different from each other. Cathode light-emission sides of two adjacent first sub-pixels are covered by at least one of the first light extraction units and at least one of the second light extraction units.

55 BRIEF DESCRIPTION OF THE DRAWINGS

[0009] In order to clearly illustrate the technical solution of the embodiments of the disclosure, the drawings of the embodiments will be briefly described in the following; it is obvious that the described drawings are only related to some

embodiments of the disclosure and thus are not limitative of the disclosure.

FIG. 1(a) is a cross-sectional schematic diagram of a structure of an organic electroluminescence display substrate provided by embodiments of the present disclosure;

FIG. 1(b) is a cross-sectional schematic diagram of another structure of the organic electroluminescence display substrate provided by the embodiments of the present disclosure;

FIG. 1(c) is a cross-sectional schematic diagram of still another structure of the organic electroluminescence display substrate provided by the embodiments of the present disclosure;

FIG. 2(a) is a Lambertian view of influence of different refractive indexes of a light extraction unit on a change of a luminance of an organic electroluminescence element with a viewing angle variation;

FIG. 2(b) is a Lambertian view of influence of different thicknesses of the light extraction unit on a change of the luminance of the organic electroluminescence element with the viewing angle variation;

FIG. 3 is a cross-sectional schematic diagram of still another structure of the organic electroluminescence display substrate provided by the embodiments of the present disclosure;

FIG. 4 is a cross-sectional schematic diagram of still another structure of the organic electroluminescence display substrate provided by the embodiments of the present disclosure;

FIG. 5 is a cross-sectional schematic diagram of still another structure of the organic electroluminescence display substrate provided by the embodiments of the present disclosure;

FIG. 6 is a cross-sectional schematic diagram of still another structure of the organic electroluminescence display substrate provided by the embodiments of the present disclosure;

FIG. 7 is a principle diagram of calculating a minimum resolving distance of a human eye;

FIG. 8 is a cross-sectional schematic diagram of still another structure of the organic electroluminescence display substrate provided by the embodiments of the present disclosure;

FIG. 9 is a cross-sectional schematic diagram of still another structure of the organic electroluminescence display substrate provided by the embodiments of the present disclosure;

FIG. 10 is a cross-sectional schematic diagram of still another structure of the organic electroluminescence display substrate provided by the embodiments of the present disclosure;

FIG. 11 is a schematic diagram of a display device provided by the embodiments of the present disclosure; and

FIG. 12 is a flow chart of a fabrication method of an organic electroluminescence display substrate provided by the embodiments of the present disclosure.

DETAILED DESCRIPTION

[0010] In order to make objects, technical details and advantages of the embodiments of the disclosure apparent, the technical solutions of the embodiments will be described in a clearly and fully understandable way in connection with the drawings related to the embodiments of the disclosure. It is obvious that the described embodiments are just a part but not all of the embodiments of the disclosure. Based on the described embodiments herein, those skilled in the art can obtain other embodiment(s), without any inventive work, which should be within the scope of the disclosure.

[0011] Unless otherwise defined, the technical terms or scientific terms here should be of general meaning as understood by those ordinarily skilled in the art. In the descriptions and claims of the present disclosure, expressions such as "first", "second" and the like do not denote any order, quantity, or importance, but rather are used for distinguishing different components. In addition, in the embodiments of the disclosure, same or similar references represent same or similar references.

[0012] Embodiments of the present disclosure provide an organic electroluminescence display substrate, a display panel, a display device, and a fabrication method of the organic electroluminescence display substrate; the organic electroluminescence display substrate, by providing at least two light extraction units with optical properties different from each other, implements improvement of a luminance viewing angle characteristic and/or a chrominance viewing angle characteristic.

[0013] At least one embodiment of the present disclosure provides the organic electroluminescence display substrate, the organic electroluminescence display substrate comprising a pixel array and a light extraction layer. The pixel array includes a plurality of pixels arranged in an array, each pixel includes a first sub-pixel emitting light of a first color, and each first sub-pixel includes an organic electroluminescence element; the light extraction layer covers on the pixel array, and for example, at least includes a plurality of first light extraction units and a plurality of second light extraction units arranged in parallel, an optical property of the first light extraction unit and an optical property of the second light extraction unit are different from each other; cathode light-emission sides of two adjacent first sub-pixels are covered by at least one of the first light extraction units and at least one of the second light extraction units. For example, the cathode light-emission side of each first sub-pixel is covered by at least one of the first light extraction units and at least one of the second light extraction units, or the cathode light-emission sides of two adjacent first sub-pixels are respectively covered

by at least one of the first light extraction units and at least one of the second light extraction units.

[0014] For example, in the embodiments of the present disclosure, the expression of "two adjacent first sub-pixels" indicates that there is no other first sub-pixel included between the above-described two adjacent first sub-pixels, but neither limits that the above-described two adjacent first sub-pixels need to be in physical contact, nor limits that other sub-pixel other than the first sub-pixel is not provided between the above-described two adjacent first sub-pixels. For example, in the case that each pixel only includes the first sub-pixel, there is not provided any sub-pixel including the first sub-pixel between the two adjacent first sub-pixels; and for another example, in the case that each pixel includes the first sub-pixel, a second sub-pixel, and a third sub-pixel, a second sub-pixel and/or a third sub-pixel may further be provided between the two adjacent first sub-pixels.

[0015] The cathode light-emission side of the organic electroluminescence element is covered by the light extraction unit, the number of surface plasma polaritons near a cathode electrode is decreased, so energy dissipation of light near the cathode electrode is decreased, and effective transmissivity of the cathode electrode is increased. The light extraction units with different thicknesses and/or different refractive indexes allow the cathode electrode to have different effective transmissivities and reflectivities, so changes of luminance and color coordinates (chrominance) of the organic electroluminescence element with a viewing angle variation are also different. By introducing at least two light extraction units and by utilizing an average effect of the at least two light extraction units on light emission luminance and the color coordinates, it is possible to implement improvement of a luminance viewing angle characteristic and/or a chrominance viewing angle characteristic of the organic electroluminescence element and the organic electroluminescence display substrate.

[0016] For example, FIG. 1(a) is a cross-sectional schematic diagram of a structure of the organic electroluminescence display substrate 10 provided by the embodiments of the present disclosure. As shown in FIG. 1(a), the organic electroluminescence display substrate 10 comprises a pixel array 100 and a light extraction layer 200. The pixel array 100 includes a plurality of pixels 110 arranged in an array (a one-dimensional array or a two-dimensional array); each pixel 110 includes a first sub-pixel 120 emitting light of a first color, and each first sub-pixel 120 includes an organic electroluminescence element 150; the organic electroluminescence element 150 is an organic electroluminescence element of top-emission type or an organic electroluminescence element of bilateral-emission type. For example, the pixel 110 only includes the first sub-pixel 120 emitting light of the first color; and for another example, according to an actual need, the pixel 110 further includes a second sub-pixel 130 emitting light of a second color and a third sub-pixel 140 emitting light of a third color, each second sub-pixel 130 and each third sub-pixel 140 include the organic electroluminescence element 150, which will not be specifically limited in the present disclosure. For example, the light extraction layer 200 covers on the pixel array 100, and includes a plurality of first light extraction units 211 and a plurality of second light extraction units 212 arranged in parallel, for example, the first light extraction unit 211 and the second light extraction unit 212 have a same thickness but different refractive indexes. A cathode light-emission side of each first sub-pixel 120 is covered by one of the first light extraction units 211 and one of the second light extraction units 212.

[0017] FIG. 1(b) is a cross-sectional schematic diagram of another structure of the organic electroluminescence display substrate provided by the embodiments of the present disclosure. As shown in FIG. 1(b), the organic electroluminescence display substrate 10 differs from the organic electroluminescence display substrate 10 shown in FIG. 1(a) in that the first light extraction unit 211 and the second light extraction unit 212 have different thicknesses. Since the first light extraction unit 211 and the second light extraction unit 212 are made of a same material, so a preparation process of the light extraction layer 200 shown in FIG. 1(b) is simpler than a preparation process of the light extraction layer 200 shown in FIG. 1(a).

[0018] FIG. 1(c) is a cross-sectional schematic diagram of still another structure of the organic electroluminescence display substrate provided by the embodiments of the present disclosure. As shown in FIG. 1(c), the first light extraction unit 211 and the second light extraction unit 212 of the organic electroluminescence display substrate 10 have different thicknesses and coverage areas. The organic electroluminescence display substrate 10 differs from the organic electroluminescence display substrate 10 shown in FIG. 1(b) in that the light extraction layer is formed in different modes, the first light extraction unit 211 and the second light extraction unit 212 shown in FIG. 1(c) include a first unit layer 241 and the second light extraction unit 212 further includes a second unit layer 242, and the second unit layer 242 covers on the first unit layer 241.

[0019] For example, a preparation method of the first light extraction unit 211 and the second light extraction unit 212 shown in FIG. 1(c) is that: firstly, the first unit layer 241 is formed on the cathode light-emission side of the pixel array 100, and then, the second unit layer 242 is formed in a region corresponding to the second light extraction unit 212, so as to implement that the first light extraction unit 211 and the second light extraction unit 212 with different thicknesses cover on a same sub-pixel. As a result, the thicknesses of the first light extraction unit 211 and the second light extraction unit 212 are more finely controlled, and the process of fabricating the first light extraction unit 211 and the second light extraction unit 212 is further simplified.

[0020] For example, the first light extraction unit 211 and the second light extraction unit 212 shown in FIG. 1(c) are formed with fine metal masks. For example, the first light extraction unit 211 and the second light extraction unit 212

shown in FIG. 1(c) are made, for example, of an organic material such as 8-hydroxyquinoline aluminum (Alq₃), or are made, for example, of an inorganic material such as titanium dioxide (TiO₂), magnesium oxide (MgO), magnesium fluoride (MgF₂), silicon dioxide (SiO₂), or are made of other suitable materials, and the formed light extraction units are capable of extracting light and are capable of improving the luminance viewing angle characteristic and/or the chrominance viewing angle characteristic.

[0021] Hereinafter, influence of the light extraction units with different refractive indexes on the change of the luminance of the organic electroluminescence element with the viewing angle variation, and a principle of improving the luminance viewing angle characteristic of the organic electroluminescence display substrate 10 shown in FIG. 1(a) by providing at least two light extraction units with different refractive indexes will be described in conjunction with a simulation result in FIG. 2(a).

[0022] A Lambertian view shown in FIG. 2(a) shows the influence of the refractive index of the light extraction unit (denoted by cpl in the drawing) on the change of red light luminance of the organic electroluminescence element 150 with the viewing angle variation, and at this time, the thickness of the light extraction layer is 55 nm (i.e., 55 nanometres). As shown in FIG. 2(a), in the case that the refractive index of the light extraction unit is relatively small (for example, n=1.4), the luminance of the organic electroluminescence element 150 is relatively strong at a viewing angle of zero (i.e., in front), the luminance rapidly decreases as the viewing angle increases, and the luminance at a large viewing angle is relatively weak; in the case that the refractive index of the light extraction unit is relatively large (for example, n=2), the luminance of the organic electroluminescence element 150 is relatively weak at the viewing angle of zero (i.e., in front), the luminance decreases slowly as the viewing angle increases, and the luminance at the large viewing angle is relatively strong.

[0023] In the case where the organic electroluminescence element 150 are covered by two light extraction units with different refractive indexes, since the two light extraction units are provided on the same organic electroluminescence element 150, effective light emission luminance of the organic electroluminescence element 150 is (light emission luminance if only the first unit layer is provided×width of the first light extraction unit 211+light emission luminance if only the second unit layer is provided×width of the second light extraction unit 212)/(width of the first light extraction unit 211+ width of the second light extraction unit 212). For example, in a case where the width of the first light extraction unit 211 and the width of the second light extraction unit 212 are the same, the effective light emission luminance of the organic electroluminescence element 150 is half the sum of the above-described two light emission luminances. Thus, in a case where one light extraction unit having relatively high luminance at the small viewing angle and having relatively low luminance at the large viewing angle, and the other light extraction unit having relatively low luminance at the small viewing angle and having relatively high luminance at the large viewing angle are provided on the same organic electroluminescence element 150, change of the luminance of the organic electroluminescence element 150 with the viewing angle variation becomes slow, so that it is possible to improve the luminance viewing angle characteristic of the organic electroluminescence element 150, and further it is possible to improve the luminance viewing angle characteristic of the organic electroluminescence display substrate 10 shown in FIG. 1(a).

[0024] Hereinafter, influence of the light extraction units with different refractive indexes on the change of red light color coordinates of the organic electroluminescence element 150 with the viewing angle variation, and a principle of improving the chrominance viewing angle characteristic of the organic electroluminescence display substrate 10 shown in FIG. 1(a) by providing at least two light extraction units with different refractive indexes will be illustrated in conjunction with a simulation result in Table 1.

[0025] Table 1 shows the influence of the light extraction unit with different refractive indexes on the change of the color coordinates of the organic electroluminescence element 150 with the viewing angle variation, CIE_x and CIE_y represent the color coordinates of the light emitted by the organic electroluminescence element 150, and Δu'Δv' represents a color shift of the organic electroluminescence element 150 with respect to a zero-degree viewing angle.

Table 1

Refractive index	Angle	CIE _x	CIE _y	Δu'Δv'
1.4+2	0	0.6348	0.3562	0
	30	0.6231	0.3678	0.018953
	60	0.6248	0.3686	0.018374
1.4	0	0.629104	0.344556	0
	30	0.606199	0.36185	0.03284
	60	0.538779	0.411725	0.114858
1.7	0	0.631645	0.342832	0

(continued)

Refractive index	Angle	CIEx	CIEy	$\Delta u' \Delta v'$
	30	0.617112	0.356856	0.023984
	60	0.538779	0.411725	0.118496
2	0	0.627435	0.346448	0
	30	0.61708	0.358883	0.019072
	60	0.610311	0.370266	0.033674

[0026] As shown in Table 1, in a case where only one light extraction unit is covered on the organic electroluminescence element 150, the color shift at the large viewing angle (for example, 60°) is relatively large; and in a case where two light extraction units respectively having refractive indexes of 1.4 and 2 are covered on the same organic electroluminescence element 150, the color shift at the large viewing angle is relatively small. Therefore, by providing two light extraction units with different refractive indexes on the same organic electroluminescence element 150, it is possible to implement improvement of the chrominance viewing angle characteristic of the organic electroluminescence element 150, and further it is possible to improve the chrominance viewing angle characteristic of the organic electroluminescence display substrate 10 shown in FIG. 1(a).

[0027] Hereinafter, influence of light extraction units with different thicknesses on the change of the luminance of the organic electroluminescence element 150 with the viewing angle variation, and a principle of improving the luminance viewing angle characteristic of the organic electroluminescence display substrate 10 shown in FIG. 1(b) and FIG. 1(c) by providing at least two light extraction units with different thicknesses will be illustrated in conjunction with a simulation result in FIG. 2(b).

[0028] The Lambertian view shown in FIG. 2(b) shows the influence of the thickness of the light extraction unit (denoted by cpl in the diagram) on the change of green light luminance with the viewing angle variation, and at this time, the refractive index of the light extraction layer is 1.8. As shown in FIG. 2(b), in the case that the thickness of the light extraction unit is 45 nanometres, the luminance of the organic electroluminescence element 150 at the large viewing angle is relatively weak; and in the case that the thickness of the light extraction unit is 65 nanometres, the luminance of the organic electroluminescence element 150 at the large viewing angle is relatively strong. Therefore, by providing two light extraction units with different thicknesses on the same organic electroluminescence element 150, it is possible to implement improvement of the luminance viewing angle characteristic of the organic electroluminescence element 150, and further it is possible to improve the luminance viewing angle characteristic of the organic electroluminescence display substrate 10 shown in FIG. 1(b) and FIG. 1(c).

[0029] Hereinafter, influence of the light extraction units with different thicknesses on the change of green light color coordinates of the organic electroluminescence element 150 with the viewing angle variation, and a principle of improving the chrominance viewing angle characteristic of the organic electroluminescence display substrate 10 shown in FIG. 1(b) and FIG. 1(c) by providing at least two light extraction units with different thicknesses will be illustrated in conjunction with a simulation result in Table 2.

[0030] Table 2 shows the influence of the light extraction units with different thicknesses on the change of the color coordinates of the organic electroluminescence element 150 with the viewing angle variation.

Table 2

	Angle	CIEx	CIEy	$\Delta u' \Delta v'$
45nm+65nm	0	0.2412	0.7136	0
	60	0.2299	0.7084	0.004348
45nm	0	0.235791	0.703793	0
	60	0.179651	0.701432	0.021888
55nm	0	0.227508	0.706337	0
	60	0.203398	0.694228	0.009436
65nm	0	0.215614	0.713421	0
	60	0.23029	0.681098	0.009705

[0031] As shown in Table 2, in a case where only one light extraction unit is covered on the organic electroluminescence element 150, the color shift at the large viewing angle is relatively large; and in a case where two light extraction units respectively having thicknesses of 45 nanometre and 60 nanometre cover on the same organic electroluminescence element 150, the color shift at the large viewing angle is relatively small. Therefore, by providing two light extraction units with different thicknesses on the same organic electroluminescence element 150, it is possible to implement improvement of the chrominance viewing angle characteristic of the organic electroluminescence element 150, and further it is possible to improve the chrominance viewing angle characteristic of the organic electroluminescence display substrate 10 shown in FIG. 1(b) and FIG. 1(c).

[0032] For example, the organic electroluminescence display substrate 10 further comprises a second sub-pixel 130 emitting light of a second color and a third sub-pixel 140 emitting light of a third color, each second sub-pixel 130 and each third sub-pixel 140 includes the organic electroluminescence element 150.

[0033] For example, FIG. 3 is a cross-sectional schematic diagram of still another structure of the organic electroluminescence display substrate 10 provided by the embodiments of the present disclosure. As shown in FIG. 3, the organic electroluminescence display substrate 10 differs from the organic electroluminescence display substrate 10 shown in FIG. 1 in that the first light extraction unit 211 and the second light extraction unit 212 not only cover the cathode light-emission side of the first sub-pixel 120, but also at least partially covers cathode light-emission sides of the adjacent second sub-pixel 130 and the adjacent third sub-pixel 140, respectively. Since the cathode light-emission side of the first sub-pixel 120 is covered by the first light extraction unit 211 and the second light extraction unit 212 with different refractive indexes or different thicknesses, it is possible to improve the luminance viewing angle characteristics and/or the chrominance viewing angle characteristics of the light of the first color of the organic electroluminescence display substrate 10. Since the widths of the first light extraction unit 211 and the second light extraction unit 212 are increased, difficulty in fabricating the light extraction layer 200 is reduced.

[0034] For example, FIG. 4 is a cross-sectional schematic diagram of still another structure of the organic electroluminescence display substrate provided by the embodiments of the present disclosure. As shown in FIG. 4, the organic electroluminescence display substrate 10 differs from the organic electroluminescence display substrate 10 shown in FIG. 1 in that the light extraction layer 200 further includes a plurality of third light extraction units 221 and a plurality of fourth light extraction unit 222 arranged in parallel. An optical property of the third light extraction unit 221 and an optical property of the fourth light extraction unit 222 are different from each other, for example, the third light extraction unit 221 and the fourth light extraction unit 222 have different refractive indexes or different thicknesses. The cathode light-emission side of each second sub-pixel 130 is covered by one third light extraction unit 221 and one fourth light extraction unit 222. Since the cathode light-emission side of the second sub-pixel 130 is covered by one third light extraction unit 221 and one fourth light extraction unit 222, the luminance viewing angle characteristic and/or the chrominance viewing angle characteristic of the light of the second color of the organic electroluminescence display substrate 10 are also improved.

[0035] For example, as shown in FIG. 4, the organic electroluminescence display substrate 10 further comprises a plurality of fifth light extraction units 231 and a plurality of sixth light extraction units 232 arranged in parallel. An optical property of the fifth light extraction unit 231 and an optical property of the sixth light extraction unit 232 are different from each other, for example, the fifth light extraction unit 231 and the sixth light extraction unit 232 have different refractive indexes or different thicknesses. The cathode light-emission side of each third sub-pixel 140 is covered by one fifth light extraction unit 231 and one sixth light extraction unit 232. Since the cathode light-emission side of the third sub-pixel 140 is covered by one fifth light extraction unit 231 and one sixth light extraction unit 232, the luminance viewing angle characteristic and/or the chrominance viewing angle characteristic of the light of the third color of the organic electroluminescence display substrate 10 are also improved.

[0036] Since the light extraction layer 200 shown in FIG. 4 have two light extraction units with different optical properties provided respectively with respect to the first sub-pixel 120, the second sub-pixel 130 and the third sub-pixel 140, the luminance viewing angle characteristics and/or the chrominance viewing angle characteristics of the light of the first color, the light of the second color and the light of the third color are better improved.

[0037] For example, in order to reduce process complexity of the organic electroluminescence display substrate 10, thicknesses and refractive indexes of the first light extraction unit, the third light extraction unit and the fifth light extraction unit shown in FIG. 4 are set to be same; for another example, thicknesses and refractive indexes of the second light extraction unit, the fourth light extraction unit and the sixth light extraction unit shown in FIG. 4 are set to be same.

[0038] For example, in order to improve the luminance viewing angle characteristics and/or the chrominance viewing angle characteristics of the light of the first color, the light of the second color and the light of the third color to a largest extent, the thicknesses and the refractive indexes of the first light extraction unit, the third light extraction unit and the fifth light extraction unit shown in FIG. 4 are set to be different from each other; and the thicknesses and the refractive indexes of the second light extraction unit, the fourth light extraction unit and the sixth light extraction unit shown in FIG. 4 are set to be different from each other.

[0039] For example, FIG. 5 is a cross-sectional schematic diagram of still another structure of the organic electrolu-

minescence display substrate 10 provided by the embodiments of the present disclosure. As shown in FIG. 5, the organic electroluminescence display substrate 10 differs from the organic electroluminescence display substrate 10 shown in FIG. 1 in that: the organic electroluminescence display substrate 10 shown in FIG. 5 further comprises the second sub-pixel 130 emitting light of the second color and the third sub-pixel 140 emitting light of the third color, each second sub-pixel 130 and each third sub-pixel 140 include the organic electroluminescence element 150. Each second sub-pixel 130 is covered by the first light extraction unit 211 and the second light extraction unit 212, and each third sub-pixel 140 is covered by the first light extraction unit 211 and the second light extraction unit 212; and the cathode light-emission sides of any two adjacent sub-pixels among the first sub-pixels 120, the second sub-pixels 130 and the third sub-pixels 140 are at least partially covered by a same first light extraction unit 211 or a same second light extraction unit 212, so that each of the first sub-pixel 120, the second sub-pixel 130 and the third sub-pixel 140 is covered by at least two light extraction layers of different optical properties.

[0040] For example, in the organic electroluminescence display substrate 10 shown in FIG. 5, the first sub-pixel 120 and the second sub-pixel 130 adjacent to each other on the left side of FIG. 5 are partially covered by the same first light extraction unit 211, and the first sub-pixel 120 and the second sub-pixel 130 adjacent to each other on the right side of FIG. 5 are partially covered by the same second light extraction unit 212; the first sub-pixel 120 and the third sub-pixel 140 on the left side of FIG. 5 are partially covered by the same second light extraction unit 212; the first sub-pixel 120 and the third sub-pixel 140 on the right side of FIG. 5 are partially covered by the same first light extraction unit 211. Since each of the first sub-pixel 120, the second sub-pixel 130 and the third sub-pixel 140 is covered by two light extraction units with different optical properties, the luminance viewing angle characteristics and/or the chrominance viewing angle characteristics of the light of the first color, the light of the second color and the light of the third color are all be improved. Since one light extraction unit is shared by every two sub-pixels, the width of the light extraction unit is increased, so that difficulty in fabricating the light extraction layer 200 is reduced.

[0041] For example, the light extraction layer shown in FIG. 5 is not limited to have only two light extraction units (i.e. the first light extraction unit and the second light extraction unit) provided, and it may have more light extraction units with optical properties different from one another provided. For example, three light extraction units (the first light extraction unit, the second light extraction unit and a seventh light extraction unit) are provided, and in this case, the first sub-pixel and the second sub-pixel adjacent to each other are partially covered by the same first light extraction unit, the first sub-pixel and the third sub-pixel adjacent to each other are partially covered by the same second light extraction unit, and the third sub-pixel and the second sub-pixel adjacent to each other are partially covered by the same seventh light extraction unit (not shown in FIG. 5). Therefore, the number of light extraction units to be provided is not limited in the present application.

[0042] For example, FIG. 6 is a cross-sectional schematic diagram of still another structure of the organic electroluminescence display substrate provided by the embodiments of the present disclosure. As shown in FIG. 6, the organic electroluminescence display substrate 10 comprises the pixel array 100 and the light extraction layer 200. The pixel array 100 includes the plurality of pixels 110 arranged in the array, each pixel 110 includes the first sub-pixel 120 emitting light of the first color, and each first sub-pixel 120 includes the organic electroluminescence element 150; the organic electroluminescence element 150 for example is the organic electroluminescence element of top-emission type or the organic electroluminescence element of bilateral-emission type. The light extraction layer 200 covers on the pixel array 100, and includes the plurality of first light extraction units 211 and the plurality of second light extraction units 212 arranged in parallel, the first light extraction unit 211 and the second light extraction unit 212 have different thicknesses or refractive indexes. The cathode light-emission sides of two adjacent first sub-pixels 120 are respectively covered by at least one of the first light extraction units 211 and at least one of the second light extraction units 212.

[0043] Hereinafter, a principle of improving the luminance viewing angle characteristic and/or the chrominance viewing angle characteristic of the organic electroluminescence display substrate 10 shown in FIG. 6 will be illustrated in conjunction with FIG. 7. Point O represents a pupil center of an eye, θ represents a minimum angle (about $1'$) of two points that are distinguished by the eye with respect to the pupil center, D represents a distance from the eye to a display screen (such distance of a mobile phone is usually 25cm), L is a minimum distance (usually greater than 0.1mm) that is distinguished by the eye. With respect to the mobile phone with resolution of QHD, a distance between two adjacent sub-pixels of a same color is less than 0.04 mm (which is about 0.02 mm for green). Thus, the human eyes are unable to distinguish two adjacent sub-pixels of the same color of the mobile phone with resolution of QHD (quarter of resolution of full high definition of 1920×1080), and deem the two adjacent sub-pixels of the same color of the mobile phone with resolution of QHD as a same light-emitting point. Therefore, with respect to the organic electroluminescence display substrate 10 shown in FIG. 6, it is equivalent to a case where the first light extraction units 211 and the second light extraction unit 212 with different optical properties are provided at the same light emission point, so that it is possible to implement improvement of the luminance viewing angle characteristic and/or the chrominance viewing angle characteristic of the light of the first color.

[0044] For example, according to an actual application need, the light extraction layer 200 is set as below: the cathode light-emission side of one first sub-pixel 120 of the two adjacent first sub-pixels 120 is covered by one first light extraction

unit 211, and the cathode light-emission side of the other first sub-pixel 120 of the two adjacent first sub-pixels 120 is covered by one second light extraction unit 212. In this case, it is also equivalent to a case where the first light extraction units 211 and the second light extraction unit 212 with different optical properties are provided at the same light emission point, so that it is also possible to implement improvement of the luminance viewing angle characteristic and/or the chrominance viewing angle characteristic of the light of the first color to a certain extent.

5 [0045] For example, the organic electroluminescence display substrate 10 further comprises the second sub-pixel 130 emitting light of the second color and the third sub-pixel 140 emitting light of the third color, each second sub-pixel 130 and each third sub-pixel 140 include the organic electroluminescence element 150.

10 [0046] For example, FIG. 8 is a cross-sectional schematic diagram of still another structure of the organic electroluminescence display substrate 10 provided by the embodiments of the present disclosure. As shown in FIG. 8, the organic electroluminescence display substrate 10 differs from the organic electroluminescence display substrate 10 shown in FIG. 6 in that the first light extraction unit 211 and the second light extraction unit 212 not only cover the cathode light-emission side of the first sub-pixel 120, but also at least partially cover the cathode light-emission sides of the second sub-pixel 130 and the third sub-pixel 140. Since the cathode light-emission sides of the two adjacent first sub-pixels 120 are respectively covered by the first light extraction unit 211 and the second light extraction unit 212 with different refractive indexes or different thicknesses, it is possible to improve the luminance viewing angle characteristics and/or the chrominance viewing angle characteristics of the light of the first color of the organic electroluminescence display substrate 10. Since the widths of the first light extraction unit 211 and the second light extraction unit 212 are increased, the difficulty in fabricating the light extraction layer 200 is reduced.

20 [0047] For example, FIG. 9 is a cross-sectional schematic diagram of still another structure of the organic electroluminescence display substrate 10 provided by the embodiments of the present disclosure. As shown in FIG. 9, the organic electroluminescence display substrate 10 differs from the organic electroluminescence display substrate 10 shown in FIG. 6 in that the light extraction layer 200 further includes the plurality of third light extraction units 221 and the plurality of fourth light extraction unit 222 arranged in parallel. The optical property of the third light extraction unit 221 and the optical property of the fourth light extraction unit 222 are different from each other, for example, the third light extraction unit 221 and the fourth light extraction unit 222 have different refractive indexes or different thicknesses. The cathode light-emission sides of two adjacent second sub-pixels 130 are respectively covered by one third light extraction unit 221 and one fourth light extraction unit 222. As a result, it is possible to improve the luminance viewing angle characteristic and/or the chrominance viewing angle characteristic of the light of the second color of the organic electroluminescence display substrate 10.

25 [0048] For example, as shown in FIG. 9, the organic electroluminescence display substrate 10 further comprises the plurality of fifth light extraction units 231 and the plurality of sixth light extraction units 232 arranged in parallel. The optical property of the fifth light extraction unit 231 and the optical property of the sixth light extraction unit 232 are different from each other, for example, the fifth light extraction unit 231 and the sixth light extraction unit 232 have different refractive indexes or different thicknesses. The cathode light-emission sides of two adjacent third sub-pixels 140 are respectively covered by one fifth light extraction unit 231 and one sixth light extraction unit 232. As a result, it is possible to improve the luminance viewing angle characteristic and/or the chrominance viewing angle characteristic of the light of the third color of the organic electroluminescence display substrate 10.

30 [0049] For example, since the light extraction layer 200 shown in FIG. 9 have two light extraction units with different optical properties provided respectively with respect to the two adjacent first sub-pixels 120, two light extraction units with different optical properties provided respectively with respect to the two adjacent second sub-pixels 130 and two light extraction units with different optical properties provided respectively with respect to the two adjacent third sub-pixels 140, the luminance viewing angle characteristics and/or the chrominance viewing angle characteristics of the light of the first color, the light of the second color and the light of the third color are improved to a largest extent.

35 [0050] For example, FIG. 10 is a cross-sectional schematic diagram of still another structure of the organic electroluminescence display substrate 10 provided by the embodiments of the present disclosure. As shown in FIG. 10, the organic electroluminescence display substrate 10 differs from the organic electroluminescence display substrate 10 shown in FIG. 6 in that the first light extraction unit 211 and the second light extraction unit 212 not only cover the cathode light-emission side of the first sub-pixel 120, but also cover the cathode light-emission sides of the second sub-pixel 130 and the third sub-pixel 140, that is to say, the first light extraction unit 211 covers one pixel 110 (for example, the pixel on the left side of FIG. 10), and the second light extraction unit 212 covers one pixel 110 (for example, the pixel on the right side of FIG. 10) adjacent to the first light extraction unit. Since the cathode light-emission sides of two adjacent first sub-pixels 120 are respectively covered by the first light extraction unit 211 and the second light extraction unit 212 with different refractive indexes or different thicknesses, the cathode light-emission sides of two adjacent second sub-pixels 130 are respectively covered by the first light extraction unit 211 and the second light extraction unit 212 with different refractive indexes or different thicknesses and the cathode light-emission sides of two adjacent third sub-pixels 140 are respectively covered by the first light extraction unit 211 and the second light extraction unit 212 with different refractive indexes or different thicknesses, the luminance viewing angle characteristics and/or the chrominance viewing angle

characteristics of the light of the first color, the light of the second color and the light of the third color of the organic electroluminescence display substrate 10 are improved. Since the widths of the first light extraction unit 211 and the second light extraction unit 212 are further increased, the difficulty in fabricating the light extraction layer 200 is further reduced.

5 **[0051]** For example, the embodiments of the present disclosure provide a display panel, and the display panel comprises the organic electroluminescence display substrate 10 provided by any one of the embodiments of the present disclosure. For example, the embodiments of the present disclosure further provide a display device. FIG. 11 is a schematic diagram the display device 20 provided by the embodiments of the present disclosure. The display device 20 comprises the organic electroluminescence display substrate 10 provided by any one of the embodiments of the present disclosure. It should be noted that, for other parts of the display panel (for example, a glass cover-plate, and the like) and other parts of the display device, those ordinarily skilled in the art should understand that there are the same, which will not be repeated here, and should not be a limitation to the present disclosure. By providing at least two light extraction units with optical properties different from each other, improvement of the luminance viewing angle characteristic and/or the chrominance viewing angle characteristic of the organic electroluminescence display substrate, as well as of the display panel and the display device comprising the organic electroluminescence display substrate is implemented.

10 **[0052]** For example, based on a same inventive concept, the embodiments of the present disclosure further provide a fabrication method of an organic electroluminescence display substrate. The fabrication method of the organic electroluminescence display substrate comprises: forming a pixel array and forming a light extraction layer. The pixel array includes a plurality of pixels arranged in an array, each pixel includes a first sub-pixel emitting light of a first color, and each first sub-pixel includes an organic electroluminescence element. The light extraction layer covers on the pixel array, and for example, at least includes a plurality of first light extraction units and a plurality of second light extraction units arranged in parallel, an optical property of the first light extraction unit and an optical property of the second light extraction unit are different from each other. Cathode light-emission sides of two adjacent first sub-pixels are covered by at least one of the first light extraction units and at least one of the second light extraction units. For example, the cathode light-emission side of each first sub-pixel is covered by at least one of the first light extraction units and at least one of the second light extraction units, or the cathode light-emission sides of two adjacent first sub-pixels are respectively covered by at least one of the first light extraction units and at least one of the second light extraction units.

20 **[0053]** For example, FIG. 12 is a flow chart of the fabrication method of the organic electroluminescence display substrate provided by the embodiments of the present disclosure. As shown in FIG. 12, the fabrication method for example comprises steps of:

Step S10: forming the pixel array;

Step S20: forming the light extraction layer.

25 **[0054]** For arrangement modes of the pixel array and the light extraction layer, the foregoing embodiments of the organic electroluminescence display substrate may be referred to, which will not be repeated here. By forming at least two light extraction units with optical properties different from each other on the cathode light-emission side of each first sub-pixel or respectively on the cathode light-emission sides of two adjacent first sub-pixels, the improvement of the luminance viewing angle characteristic and/or the chrominance viewing angle characteristic of the organic electroluminescence display substrate is implemented.

30 **[0055]** The embodiments of the present disclosure provide the organic electroluminescence display substrate, the display device, and the fabrication method of the organic electroluminescence display substrate; and the organic electroluminescence display substrate, by providing at least two light extraction units with optical properties different from each other, implements the improvement of the luminance viewing angle characteristic and/or the chrominance viewing angle characteristic.

35 **[0056]** Although the present disclosure is described in detail hereinbefore with general illustration and specific embodiments, based on the embodiments of the present disclosure, certain variations or modifications can be made thereto, which is obvious for those skilled in the art. Therefore, all such variations or modifications without departing from the spirit of the present disclosure are within the scope of the claims of the present disclosure.

40 **[0057]** The present application claims priority of the Chinese Patent Application No. 201611091447.X filed on December 01, 2016, the disclosure of which are incorporated herein by its reference in its entirety as part of the present application.

55 **Claims**

1. An organic electroluminescence display substrate, comprising:

a pixel array, wherein, the pixel array includes a plurality of pixels arranged in an array, each of the pixels includes a first sub-pixel emitting light of a first color, and each of the first sub-pixels includes an organic electroluminescence element;

5 a light extraction layer, covering on the pixel array and at least including a plurality of first light extraction units and a plurality of second light extraction units, and an optical property of the first light extraction unit and an optical property of the second light extraction unit being different from each other;

wherein, cathode light-emission sides of two adjacent first sub-pixels are covered by at least one of the first light extraction units and at least one of the second light extraction units.

- 10 **2.** The organic electroluminescence display substrate according to claim 1, wherein, the cathode light-emission side of each of the first sub-pixels is covered by at least one of the first light extraction units and at least one of the second light extraction units, or the cathode light-emission sides of two adjacent first sub-pixels are respectively covered by at least one of the first light extraction units and at least one of the second light extraction units.
- 15 **3.** The organic electroluminescence display substrate according to claim 1, wherein, the first light extraction unit and the second light extraction unit have different thicknesses or different refractive indexes.
- 4.** The organic electroluminescence display substrate according to claim 3, wherein, the first light extraction unit and the second light extraction unit include a first unit layer, the second light extraction unit further includes a second unit layer, and the second unit layer covers on the first unit layer.
- 20 **5.** The organic electroluminescence display substrate according to any one of claims 1 to 4, wherein, each of the pixel arrays further includes a second sub-pixel emitting light of a second color and a third sub-pixel emitting light of a third color, each of the second sub-pixels and each of the third sub-pixels include the organic electroluminescence element.
- 25 **6.** The organic electroluminescence display substrate according to claim 5, wherein, each of the second sub-pixels is covered by at least one of the first light extraction units and at least one of the second light extraction units, each of the third sub-pixels is covered by at least one of the first light extraction units and at least one of the second light extraction units, and cathode light-emission sides of any two adjacent sub-pixels among the first sub-pixels, the second sub-pixels and the third sub-pixels are at least partially covered by a same first light extraction unit or a same second light extraction unit.
- 30 **7.** The organic electroluminescence display substrate according to claim 5, further comprising a plurality of third light extraction units and a plurality of fourth light extraction units arranged in parallel, an optical property of the third light extraction unit and an optical property of the fourth light extraction unit being different from each other, wherein, a cathode light-emission side of each of the second sub-pixels is covered by at least one of the third light extraction units and at least one of the fourth light extraction units, or the cathode light-emission sides of two adjacent second sub-pixels are respectively covered by at least one of the third light extraction units and at least one of the fourth light extraction units.
- 35 **8.** The organic electroluminescence display substrate according to claim 7, further comprising a plurality of fifth light extraction units and a plurality of sixth light extraction units arranged in parallel, wherein, an optical property of the fifth light extraction unit and an optical property of the sixth light extraction unit are different from each other, wherein, a cathode light-emission side of each of the third sub-pixels is covered by at least one of the fifth light extraction units and at least one of the sixth light extraction units, or the cathode light-emission sides of two adjacent third sub-pixels are respectively covered by at least one of the fifth light extraction units and at least one of the sixth light extraction units.
- 40 **9.** The organic electroluminescence display substrate according to claim 8, wherein, the optical property of the first light extraction unit, the optical property of the third light extraction unit and the optical property of the fifth light extraction unit are the same, and the optical property of the second light extraction unit, the optical property of the fourth light extraction unit, and the optical property of the sixth light extraction unit are the same.
- 45 **10.** The organic electroluminescence display substrate according to any one of claims 1 to 4, wherein, cathode light-emission sides of two adjacent pixels are respectively covered by at least one of the first light extraction units and at least one of the second light extraction units.
- 50
- 55

11. The organic electroluminescence display substrate according to any one of claims 1 to 10, wherein, the organic electroluminescence element is an organic electroluminescence element of top-emission type or an organic electroluminescence element of bilateral-emission type.

5 12. A display panel, comprising the organic electroluminescence display substrate according to any one of claims 1 to 11.

13. A display device, comprising the organic electroluminescence display substrate according to any one of claims 1 to 11 or the display panel according to claim 12.

10 14. A fabrication method of an organic electroluminescence display substrate according to any one of claims 1 to 11, comprising:

forming a pixel array, wherein, the pixel array includes a plurality of pixels arranged in an array, each of the pixels includes a first sub-pixel emitting light of a first color, and each of the first sub-pixels includes an organic electroluminescence element;

15 forming a light extraction layer, covering on the pixel array and at least including a plurality of first light extraction units and a plurality of second light extraction units, an optical property of the first light extraction unit and an optical property of the second light extraction unit being different from each other;

20 wherein, cathode light-emission sides of two adjacent first sub-pixels are covered by at least one of the first light extraction units and at least one of the second light extraction units.

15. The fabrication method of the organic electroluminescence display substrate according to claim 14, wherein, the cathode light-emission side of each of the first sub-pixels is covered by at least one of the first light extraction units and at least one of the second light extraction units, or the cathode light-emission sides of two adjacent first sub-pixels are respectively covered by at least one of the first light extraction units and at least one of the second light extraction units.

25

16. The fabrication method of the organic electroluminescence display substrate according to claim 14 or 15, wherein, the first light extraction unit and the second light extraction unit have different thicknesses or different refractive indexes.

30

17. The fabrication method of the organic electroluminescence display substrate according to claim 14 or 15, wherein, the first light extraction unit and the second light extraction unit include a first unit layer, the second light extraction unit further includes a second unit layer, and the second unit layer covers on the first unit layer.

35

18. The fabrication method of the organic electroluminescence display substrate according to any one of claims 14 to 17, wherein, each of the pixel arrays further includes a second sub-pixel emitting light of a second color and a third sub-pixel emitting light of a third color, each of the second sub-pixels and each of the third sub-pixels includes the organic electroluminescence element.

40

19. The fabrication method of the organic electroluminescence display substrate according to claim 18, wherein, each of the second sub-pixels is covered by at least one of the first light extraction units and at least one of the second light extraction units, each of the third sub-pixels is covered by at least one of the first light extraction units and at least one of the second light extraction units, and cathode light-emission sides of any two adjacent sub-pixels among the first sub-pixels, the second sub-pixels and the third sub-pixels are at least partially covered by a same first light extraction unit or a same second light extraction unit.

45

50

55

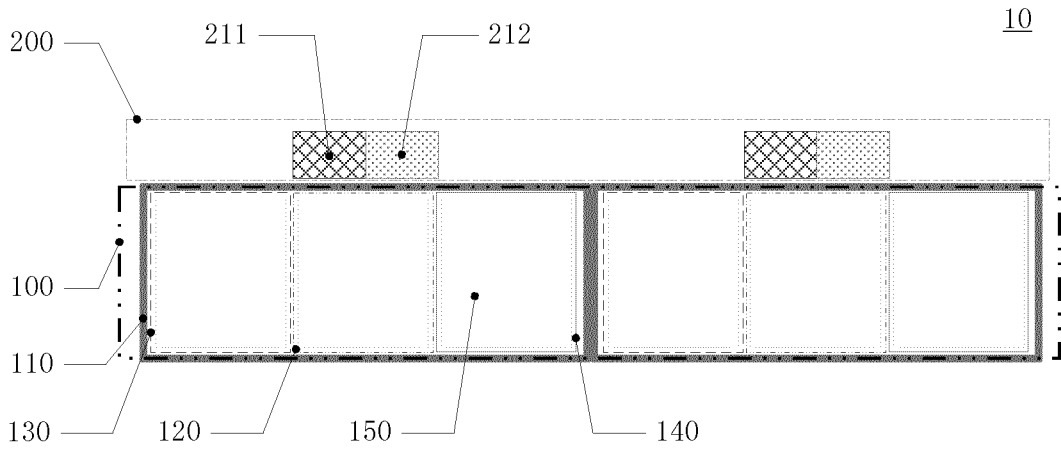

FIG. 1(a)

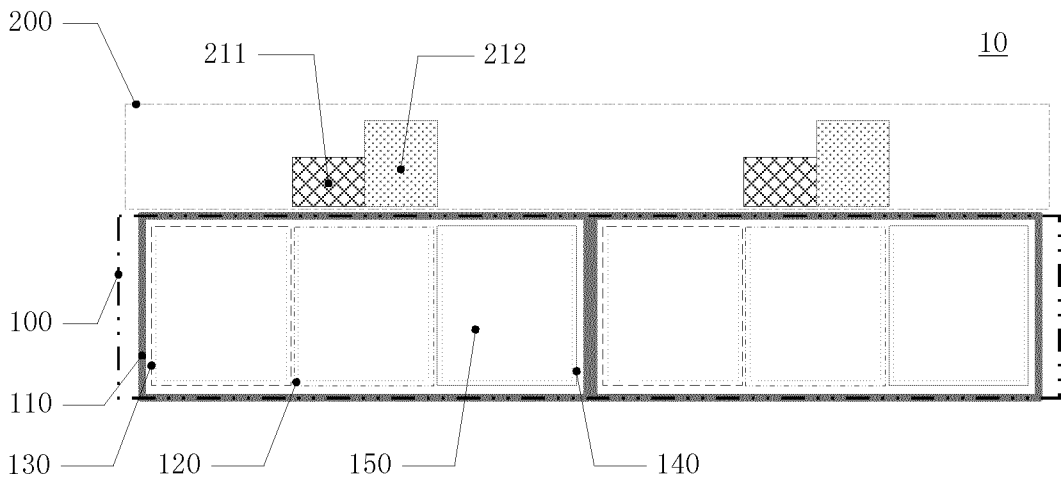

FIG. 1(b)

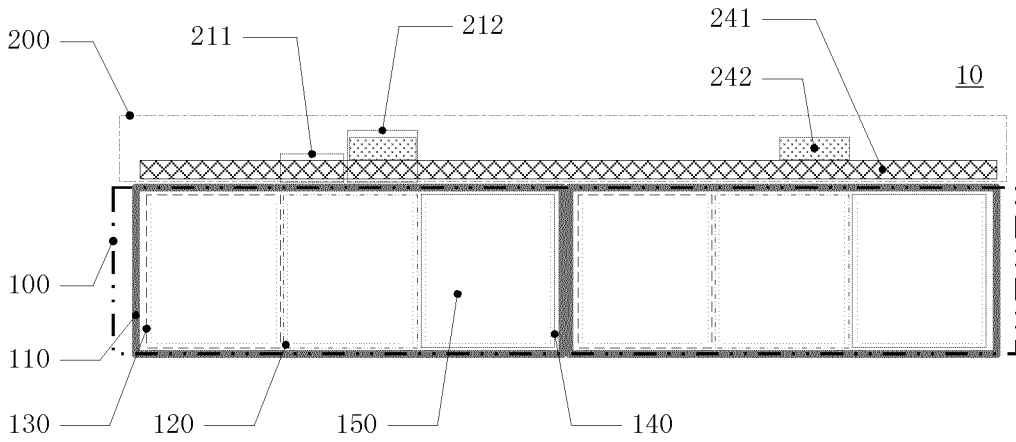

FIG. 1(c)

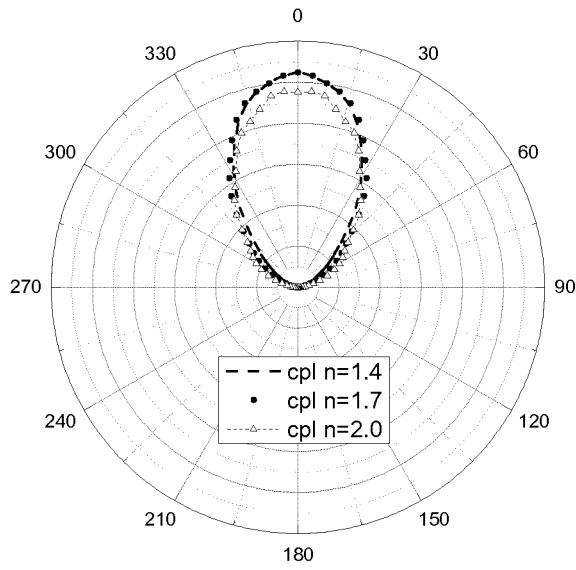

FIG. 2(a)

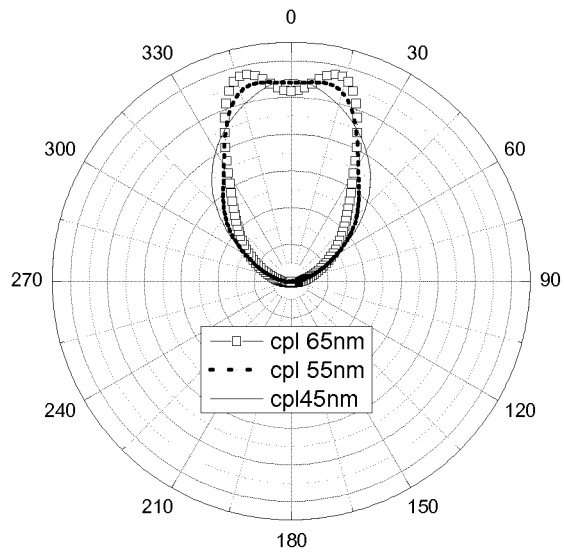

FIG. 2(b)

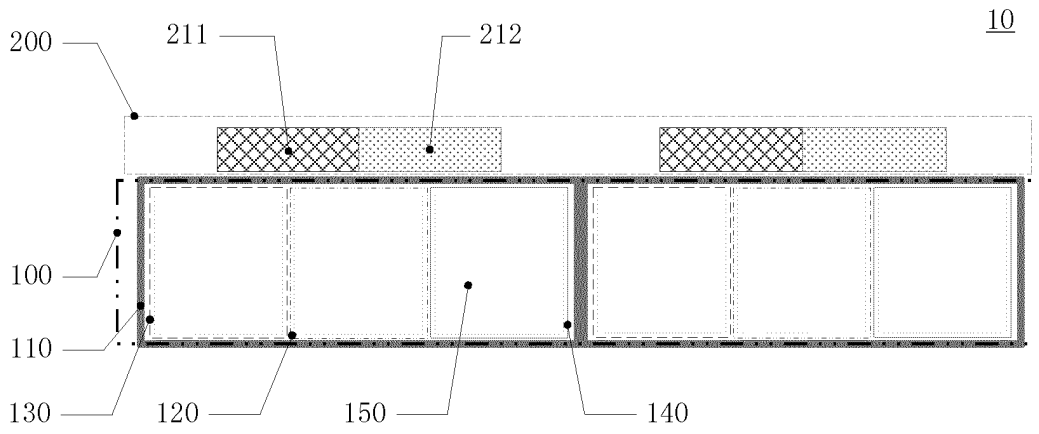

FIG. 3

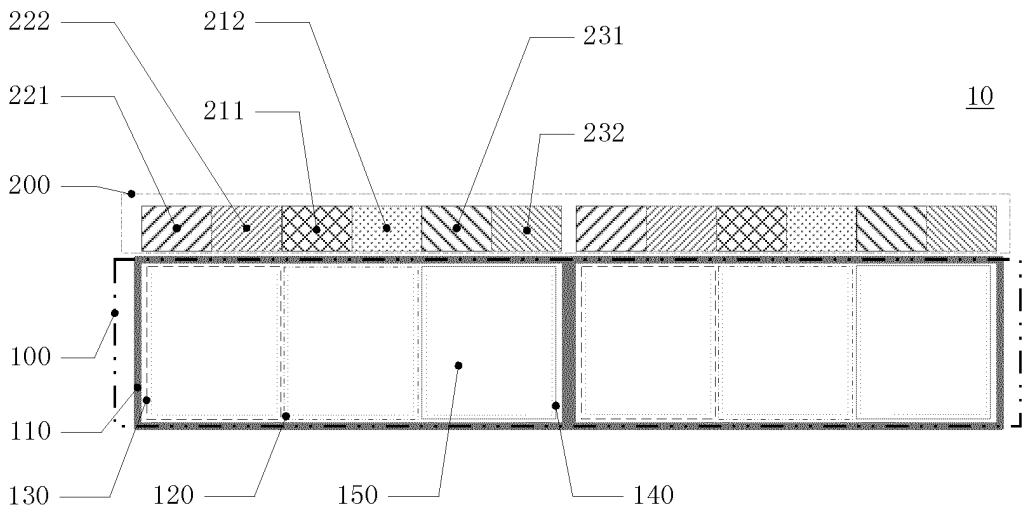

FIG. 4

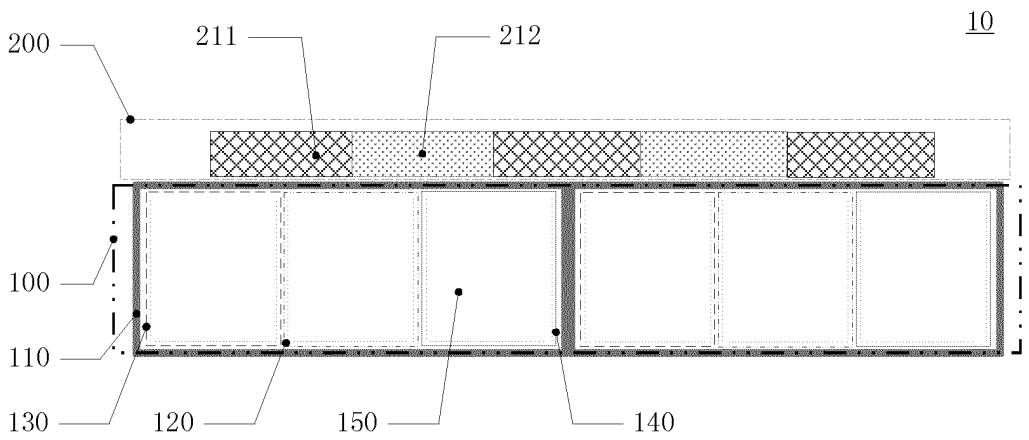

FIG. 5

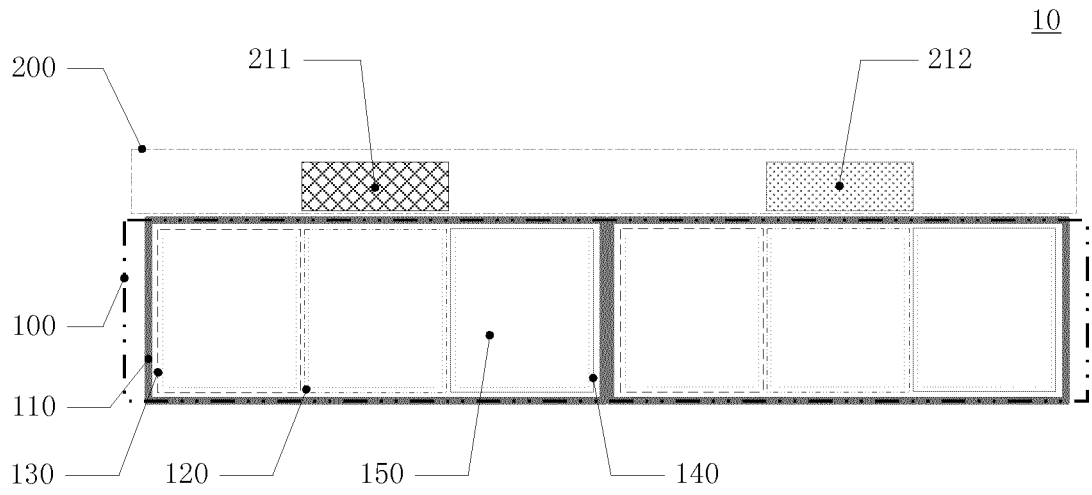

FIG. 6

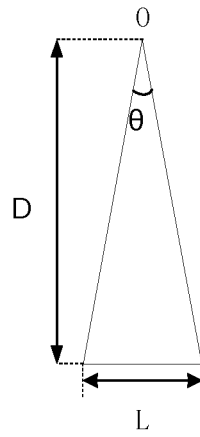

FIG. 7

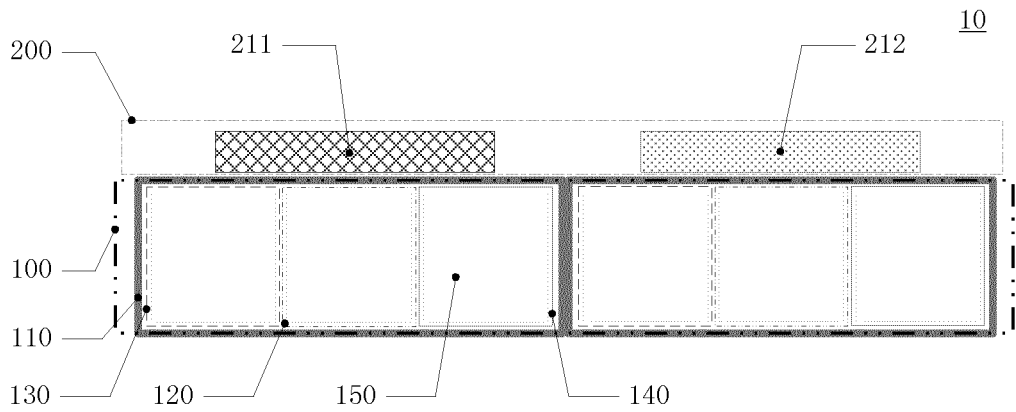

FIG. 8

INTERNATIONAL SEARCH REPORT

International application No.

PCT/CN2017/091189

A. CLASSIFICATION OF SUBJECT MATTER

H01L 27/32 (2006.01) i; H01L 51/52 (2006.01) i; H01L 51/56 (2006.01) i

According to International Patent Classification (IPC) or to both national classification and IPC

B. FIELDS SEARCHED

Minimum documentation searched (classification system followed by classification symbols)

H01L

Documentation searched other than minimum documentation to the extent that such documents are included in the fields searched

Electronic data base consulted during the international search (name of data base and, where practicable, search terms used)

CNABS; CPRSABS; SIPOABS; DWPI; CNKI: 像素, 象素, 画素, 第二, 另一, 又一, 另外, 子, 亚, 次, 额外, 附加, 不同, 不相同, 各不相同, 互不相同, 光, 取, 显示, 面板, 厚, 折射, pixel?, second, another, addition+, sub, differ+, light extract+, light pick+, display, panel, thickness, refract+

C. DOCUMENTS CONSIDERED TO BE RELEVANT

Category*	Citation of document, with indication, where appropriate, of the relevant passages	Relevant to claim No.
X	CN 106158905 A (EVERDISPLAY OPTRONICS (SHANGHAI) LIMITED), 23 November 2016 (23.11.2016), description, paragraphs [0049]-[0075], and figures 1-2	1-3, 5-6, 11-16, 18-19
PX	KR 20160141060 A (ELECTRONICS & TELECOM RES INST), 08 December 2016 (08.12.2016), description, paragraphs [0010]-[0053], and figures 1-6	1-3, 5-6, 11-16, 18-19
A	JP 2004287053 A (FUJI PHOTO FILM CO., LTD.), 14 October 2004 (14.10.2004), entire document	1-19

 Further documents are listed in the continuation of Box C. See patent family annex.

* Special categories of cited documents:

"A" document defining the general state of the art which is not considered to be of particular relevance

"E" earlier application or patent but published on or after the international filing date

"L" document which may throw doubts on priority claim(s) or which is cited to establish the publication date of another citation or other special reason (as specified)

"O" document referring to an oral disclosure, use, exhibition or other means

"P" document published prior to the international filing date but later than the priority date claimed

"T" later document published after the international filing date or priority date and not in conflict with the application but cited to understand the principle or theory underlying the invention

"X" document of particular relevance; the claimed invention cannot be considered novel or cannot be considered to involve an inventive step when the document is taken alone

"Y" document of particular relevance; the claimed invention cannot be considered to involve an inventive step when the document is combined with one or more other such documents, such combination being obvious to a person skilled in the art

"&" document member of the same patent family

Date of the actual completion of the international search

09 August 2017

Date of mailing of the international search report

31 August 2017

Name and mailing address of the ISA
State Intellectual Property Office of the P. R. China
No. 6, Xitucheng Road, Jimenqiao
Haidian District, Beijing 100088, China
Facsimile No. (86-10) 62019451

Authorized officer

TIAN, Shufeng

Telephone No. (86-10) 62089264

INTERNATIONAL SEARCH REPORT
 Information on patent family members

International application No.
 PCT/CN2017/091189

5
 10
 15
 20
 25
 30
 35
 40
 45
 50
 55

Patent Documents referred in the Report	Publication Date	Patent Family	Publication Date
CN 106158905 A	23 November 2016	US 2016315290 A1	27 October 2016
KR 20160141060 A	08 December 2016	None	
JP 2004287053 A	14 October 2004	None	

Form PCT/ISA/210 (patent family annex) (July 2009)

REFERENCES CITED IN THE DESCRIPTION

This list of references cited by the applicant is for the reader's convenience only. It does not form part of the European patent document. Even though great care has been taken in compiling the references, errors or omissions cannot be excluded and the EPO disclaims all liability in this regard.

Patent documents cited in the description

- CN 201611091447X [0057]

专利名称(译)	有机电致发光显示基板及其制造方法，显示面板和显示装置		
公开(公告)号	EP3550608A1	公开(公告)日	2019-10-09
申请号	EP2017829908	申请日	2017-06-30
[标]申请(专利权)人(译)	京东方科技集团股份有限公司		
申请(专利权)人(译)	京东方科技集团股份有限公司.		
当前申请(专利权)人(译)	京东方科技集团股份有限公司.		
[标]发明人	FAN XING YAN GUANG		
发明人	FAN, XING YAN, GUANG		
IPC分类号	H01L27/32 H01L51/52 H01L51/56		
CPC分类号	H01L27/3211 H01L51/5262 H01L51/5275 H01L51/56 H01L51/5265 H01L2251/5315 H01L27/32 H01L51/52		
优先权	201611091447.X 2016-12-01 CN		
外部链接	Espacenet		

摘要(译)

提供了一种有机电致发光显示基板及其制造方法，显示面板和显示装置。有机电致发光显示基板（10）包括像素阵列（100）和光提取层（200）。像素阵列（100）包括多个像素（110），每个像素（110）包括发射第一颜色的光的第一子像素（120），并且每个第一子像素（120）包括有机电致发光元件。（150）。光提取层（100）覆盖在像素阵列（100）上，并且至少包括平行布置并具有不同光学特性的多个第一光提取单元（211）和多个第二光提取单元（212）。每个第一子像素（120）的阴极发光侧被至少一个第一光提取单元（211）和至少一个第二光提取单元（212）覆盖，或者被两个相邻的阴极发光侧覆盖。第一子像素（120）分别被至少一个第一光提取单元（211）和至少一个第二光提取单元（212）覆盖。通过提供至少两个具有彼此不同的光学特性的光提取单元，实现了亮度视角特性和/或色度视角特性的改善。

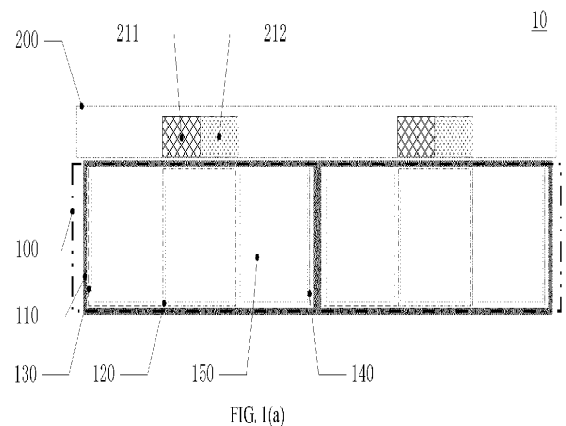

FIG. 1(a)