



(12) **EUROPEAN PATENT APPLICATION**

(88) Date of publication A3: **08.07.2015 Bulletin 2015/28** (51) Int Cl.: **G09G 3/32 (2006.01)**

(43) Date of publication A2: **10.06.2015 Bulletin 2015/24**

(21) Application number: **14193569.2**

(22) Date of filing: **18.11.2014**

(84) Designated Contracting States:
AL AT BE BG CH CY CZ DE DK EE ES FI FR GB GR HR HU IE IS IT LI LT LU LV MC MK MT NL NO PL PT RO RS SE SI SK SM TR
 Designated Extension States:
BA ME

(72) Inventors:
 • **Nam, Woojin**
411-320 Gyeonggi-do (KR)
 • **Choi, Jintaek**
411-310 Gyeonggi-do (KR)
 • **Choi, Seongmin**
506-304 Gwangju (KR)

(30) Priority: **03.12.2013 KR 20130149395**

(74) Representative: **Urner, Peter**
Ter Meer Steinmeister & Partner
Patentanwälte mbB
Mauerkircherstrasse 45
81679 München (DE)

(71) Applicant: **LG Display Co., Ltd.**
Yeongdeungpo-gu
Seoul
150-721 (KR)

(54) **Organic light emitting display and method of compensating for image quality thereof**

(57) Provided is an organic light emitting diode (OLED) display device including a plurality of pixels (P) to display images, each of the pixels (P) including an OLED, a driving transistor (DT) connected to the OLED, and a switching transistor (ST1, ST2) configured to supply data signals to the OLED, the device including: a sensing unit (30) configured to sense a change amount of a mobility of the driving transistor (DT); a compensation

value calculator (41) configured to obtain a change amount of a threshold voltage of the driving transistor (DT) based on the sensed change amount of the mobility; and a data compensator (50) configured to adjust the data signals based on the sensed change amount of mobility and the obtained change amount of the threshold voltage.

FIG. 12

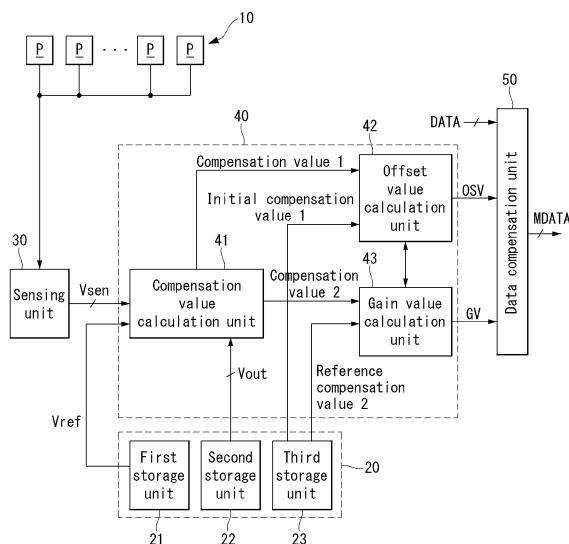



EUROPEAN SEARCH REPORT

Application Number
EP 14 19 3569

5

10

15

20

25

30

35

40

45

50

55

DOCUMENTS CONSIDERED TO BE RELEVANT				
Category	Citation of document with indication, where appropriate, of relevant passages	Relevant to claim	CLASSIFICATION OF THE APPLICATION (IPC)	
Y	US 2013/083001 A1 (JEONG UI TAEK [KR]) 4 April 2013 (2013-04-04) * paragraphs [0026] - [0030], [0035], [0048], [0057], [0060] - [0076], [0085] - [0106], [0109]; figures 1,2,3,4,6,7,8 *	1-6,9-14	INV. G09G3/32	
Y	US 2011/032264 A1 (IETOMI KUNIHICO [JP]) 10 February 2011 (2011-02-10) * paragraphs [0024] - [0026], [0041] - [0046], [0050] - [0054], [0059], [0074]; figures 3,4,5 *	1-6,9-14		
Y	US 2010/188390 A1 (MIN UNG-GYU [KR] ET AL) 29 July 2010 (2010-07-29) * paragraphs [0005] - [0008], [0080] - [0104]; figures 4,6,7 *	3		
A	WO 2009/145881 A1 (EASTMAN KODAK CO [US]; LEVEY CHARLES L [US]; WINTERS DUSTIN [US]; HAME) 3 December 2009 (2009-12-03) * page 15, lines 1-23; figures 3,4 * * page 17, line 12 - page 18, line 11 * * page 21, lines 5-8 *	7,15		TECHNICAL FIELDS SEARCHED (IPC)
A	US 2010/039422 A1 (SETO YASUHIRO [JP]) 18 February 2010 (2010-02-18) * paragraphs [0140] - [0195] *	7,15		G09G
A	WO 2009/075242 A1 (CANON KK [JP]; IWASAKI TATSUYA [JP]; ITAGAKI NAHO [JP]) 18 June 2009 (2009-06-18) * page 20, line 24 - page 21, line 8 *	8,16		
The present search report has been drawn up for all claims				
Place of search Munich		Date of completion of the search 2 June 2015	Examiner Taron, Laurent	
CATEGORY OF CITED DOCUMENTS X : particularly relevant if taken alone Y : particularly relevant if combined with another document of the same category A : technological background O : non-written disclosure P : intermediate document		T : theory or principle underlying the invention E : earlier patent document, but published on, or after the filing date D : document cited in the application L : document cited for other reasons & : member of the same patent family, corresponding document		

EPO FORM 1503 03.82 (P04C01)



Application Number

EP 14 19 3569

5

10

15

20

25

30

35

40

45

50

55

CLAIMS INCURRING FEES

The present European patent application comprised at the time of filing claims for which payment was due.

Only part of the claims have been paid within the prescribed time limit. The present European search report has been drawn up for those claims for which no payment was due and for those claims for which claims fees have been paid, namely claim(s):

No claims fees have been paid within the prescribed time limit. The present European search report has been drawn up for those claims for which no payment was due.

LACK OF UNITY OF INVENTION

The Search Division considers that the present European patent application does not comply with the requirements of unity of invention and relates to several inventions or groups of inventions, namely:

see sheet B

All further search fees have been paid within the fixed time limit. The present European search report has been drawn up for all claims.

As all searchable claims could be searched without effort justifying an additional fee, the Search Division did not invite payment of any additional fee.

Only part of the further search fees have been paid within the fixed time limit. The present European search report has been drawn up for those parts of the European patent application which relate to the inventions in respect of which search fees have been paid, namely claims:

None of the further search fees have been paid within the fixed time limit. The present European search report has been drawn up for those parts of the European patent application which relate to the invention first mentioned in the claims, namely claims:

The present supplementary European search report has been drawn up for those parts of the European patent application which relate to the invention first mentioned in the claims (Rule 164 (1) EPC).

**LACK OF UNITY OF INVENTION
SHEET B**

Application Number

EP 14 19 3569

5

The Search Division considers that the present European patent application does not comply with the requirements of unity of invention and relates to several inventions or groups of inventions, namely:

10

1. claims: 1, 2, 4-6, 9, 10, 12-14(completely); 3, 11(partially)

OLED display device wherein a change amount of a threshold voltage is determined based on a sensed change amount of mobility

15

2. claims: 3, 11(all partially)

OLED display device wherein a change amount of mobility is sensed during a vertical blank period

20

3. claims: 7, 8, 15, 16

25

OLED display device wherein a change amount of the mobility is based on the comparison between a slope of a graph and a reference slope and a change amount of threshold is based on the difference of an intercept of the graph with an x-axis and a reference intercept

30

35

40

45

50

55

ANNEX TO THE EUROPEAN SEARCH REPORT
ON EUROPEAN PATENT APPLICATION NO.

EP 14 19 3569

5

This annex lists the patent family members relating to the patent documents cited in the above-mentioned European search report. The members are as contained in the European Patent Office EDP file on The European Patent Office is in no way liable for these particulars which are merely given for the purpose of information.

02-06-2015

10

Patent document cited in search report	Publication date	Patent family member(s)	Publication date
US 2013083001 A1	04-04-2013	CN 103077662 A	01-05-2013
		KR 20130036661 A	12-04-2013
		US 2013083001 A1	04-04-2013
US 2011032264 A1	10-02-2011	CN 101996551 A	30-03-2011
		JP 2011034004 A	17-02-2011
		US 2011032264 A1	10-02-2011
		US 2011032281 A1	10-02-2011
US 2010188390 A1	29-07-2010	KR 20100086876 A	02-08-2010
		US 2010188390 A1	29-07-2010
WO 2009145881 A1	03-12-2009	CN 102047313 A	04-05-2011
		EP 2294568 A1	16-03-2011
		JP 5485986 B2	07-05-2014
		JP 2011523720 A	18-08-2011
		KR 20110023867 A	08-03-2011
		US 2009295422 A1	03-12-2009
		WO 2009145881 A1	03-12-2009
US 2010039422 A1	18-02-2010	JP 5107824 B2	26-12-2012
		JP 2010044299 A	25-02-2010
		US 2010039422 A1	18-02-2010
WO 2009075242 A1	18-06-2009	CN 101897030 A	24-11-2010
		CN 102394248 A	28-03-2012
		JP 5213429 B2	19-06-2013
		JP 2009147069 A	02-07-2009
		TW 200939483 A	16-09-2009
		US 2010224870 A1	09-09-2010
		WO 2009075242 A1	18-06-2009

15

20

25

30

35

40

45

50

55

EPO FORM P0459

For more details about this annex : see Official Journal of the European Patent Office, No. 12/82

专利名称(译)	有机发光显示器和补偿其图像质量的方法		
公开(公告)号	EP2881932A3	公开(公告)日	2015-07-08
申请号	EP2014193569	申请日	2014-11-18
[标]申请(专利权)人(译)	乐金显示有限公司		
申请(专利权)人(译)	LG DISPLAY CO. , LTD.		
当前申请(专利权)人(译)	LG DISPLAY CO. , LTD.		
[标]发明人	NAM WOJIN CHOI JINTAEK CHOI SEONGMIN		
发明人	NAM, WOJIN CHOI, JINTAEK CHOI, SEONGMIN		
IPC分类号	G09G3/32		
优先权	1020130149395 2013-12-03 KR		
其他公开文献	EP2881932B1 EP2881932A2		
外部链接	Espacenet		

摘要(译)

提供一种有机发光二极管 (OLED) 显示装置, 包括显示图像的多个像素 (P), 每个像素 (P) 包括OLED, 连接到OLED的驱动晶体管 (DT) 和开关晶体管 (ST1, ST2), 被配置为向OLED提供数据信号, 该装置包括: 感测单元 (30), 被配置为感测驱动晶体管 (DT) 的迁移率的变化量; 补偿值计算器 (41), 被配置为基于所感测的迁移率的变化量来获得驱动晶体管 (DT) 的阈值电压的变化量; 数据补偿器 (50), 被配置为基于所感测的迁移率的变化量和所获得的阈值电压的变化量来调整数据信号。

FIG. 12

