



(12) EUROPEAN PATENT APPLICATION

(88) Date of publication A3: 19.07.2006 Bulletin 2006/29  
(51) Int Cl.: G09G 3/32<sup>(2006.01)</sup>  
(43) Date of publication A2: 10.08.2005 Bulletin 2005/32  
(21) Application number: 05002000.7  
(22) Date of filing: 01.02.2005

(84) Designated Contracting States:  
AT BE BG CH CY CZ DE DK EE ES FI FR GB GR  
HU IE IS IT LI LT LU MC NL PL PT RO SE SI SK TR  
Designated Extension States:  
AL BA HR LV MK YU  
(30) Priority: 03.02.2004 KR 2004006879  
03.02.2004 KR 2004006880

- Lee, Jae Do,  
3-5, Kyoungdong Heights  
Gumi-si,  
Gyeongsangbuk-do (KR)
- Kim, Ki Heon,  
LG Electronics  
Gumi-si  
Gyeongsangbuk-do (KR)
- Seo, Jung Min  
Nam-gu  
Daegu (KR)
- Kim, Hyun Joung  
Daegu (KR)

(71) Applicant: LG ELECTRONICS INC.  
Seoul (KR)

(74) Representative: Sajda, Wolf E. et al  
Meissner, Bolte & Partner GbR,  
Postfach 10 26 05  
86016 Augsburg (DE)

(72) Inventors:  
• Ha, Won Kyu  
Yeongdeok-gun,  
Gyeongsangbuk-do (KR)  
• Kim, Hak Su  
Gangbuk-gu  
Seoul (KR)

(54) Electro-luminescence display device and driving method thereof

(57) There is disclosed an electro-luminescence display device that is adaptive for preventing picture quality deterioration by operating a thin film transistor for an electro-luminescence cell drive at a non-saturation area to compensate a threshold voltage, and a driving method thereof.

An electro-luminescence display device according to an embodiment of the present invention includes an electro-luminescence cell connected between a first supply voltage source and a ground voltage source to emit light by a current supplied from the first supply voltage source; a cell driver formed every intersection of gate lines and data lines and connected between the first supply voltage source and the electro-luminescence cell to control a current flowing in the pixel cell; and a pulse supplier supplies to the electro-luminescence cell a pulse amplitude modulation signal which is divided to have N (N is a natural number) numbers of different voltage levels from each other, and wherein the driving thin film transistor operates at the non-saturation region.

FIG. 4

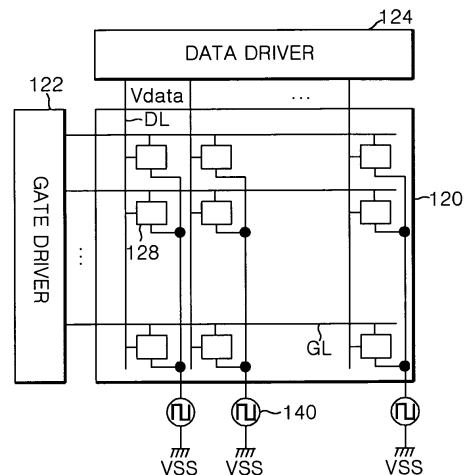



DOCUMENTS CONSIDERED TO BE RELEVANT			
Category	Citation of document with indication, where appropriate, of relevant passages	Relevant to claim	CLASSIFICATION OF THE APPLICATION (IPC)
X	US 5 990 629 A (YAMADA ET AL) 23 November 1999 (1999-11-23) * figures 1,8,14 * * column 1, line 5 - line 9 * * column 5, line 40 - line 45 * * column 6, line 18 - line 31 * * column 14, line 43 - line 57 * -----	1-45	INV. G09G3/32
			TECHNICAL FIELDS SEARCHED (IPC)
			G09G
The present search report has been drawn up for all claims			
Place of search <b>The Hague</b>		Date of completion of the search <b>29 May 2006</b>	Examiner <b>Ladiray, 0</b>
<b>CATEGORY OF CITED DOCUMENTS</b> X : particularly relevant if taken alone Y : particularly relevant if combined with another document of the same category A : technological background O : non-written disclosure P : intermediate document		T : theory or principle underlying the invention E : earlier patent document, but published on, or after the filing date D : document cited in the application L : document cited for other reasons ..... & : member of the same patent family, corresponding document	

2  
EPO FORM 1503 03.02 (P04C01)

**ANNEX TO THE EUROPEAN SEARCH REPORT  
ON EUROPEAN PATENT APPLICATION NO.**

EP 05 00 2000

This annex lists the patent family members relating to the patent documents cited in the above-mentioned European search report. The members are as contained in the European Patent Office EDP file on  
The European Patent Office is in no way liable for these particulars which are merely given for the purpose of information.

29-05-2006

Patent document cited in search report	Publication date	Patent family member(s)	Publication date
US 5990629	A	23-11-1999	CA 2249592 A1 30-07-1998
			CN 1216135 A 05-05-1999
			EP 0906609 A1 07-04-1999
			WO 9833165 A1 30-07-1998
			TW 441136 B 16-06-2001
-----			

EPO FORM P0459

For more details about this annex : see Official Journal of the European Patent Office, No. 12/82

专利名称(译)	电致发光显示装置及其驱动方法		
公开(公告)号	<a href="#">EP1562168A3</a>	公开(公告)日	2006-07-19
申请号	EP2005002000	申请日	2005-02-01
申请(专利权)人(译)	LG电子株式会社.		
当前申请(专利权)人(译)	LG电子株式会社.		
[标]发明人	HA WON KYU KIM HAK SU KIM KI HEON LG ELECTRONICS SEO JUNG MIN KIM HYUN JOUNG		
发明人	HA, WON KYU KIM, HAK SU LEE, JAE DO, 3-5, KYOUNGDONG HEIGHTS KIM, KI HEON, LG ELECTRONICS SEO, JUNG MIN KIM, HYUN JOUNG		
IPC分类号	G09G3/32 H01L51/50 G09G3/20 G09G3/30 G09G3/36 H03K17/00 H03M1/66 H05B33/08 H05B33/14		
CPC分类号	G09G3/2011 G09G3/2022 G09G3/2081 G09G3/3233 G09G3/3291 G09G3/3655 G09G2300/0842 G09G2300/0866 G09G2310/027 G09G2320/043		
优先权	1020040006880 2004-02-03 KR 1020040006879 2004-02-03 KR		
其他公开文献	EP1562168A2		
外部链接	<a href="#">Espacenet</a>		

摘要(译)

公开了一种电致发光显示装置及其驱动方法，该电致发光显示装置适于通过非饱和区域操作于电致发光单元驱动的薄膜晶体管来补偿阈值电压来防止图像质量劣化。根据本发明实施例的电致发光显示装置包括连接在第一电源电压源和接地电压源之间的电致发光单元，以通过从第一电源电压源提供的电流发光。单元驱动器形成栅极线和数据线的每个交叉点，并连接在第一电源电压源和电致发光单元之间，以控制在像素单元中流动的电流；并且脉冲供应器向电致发光单元提供脉冲幅度调制信号，该脉冲幅度调制信号被划分为具有彼此不同的电压电平的N（N是自然数）个数，并且其中驱动薄膜晶体管在非电压电平下工作。饱和区域。

FIG. 4

