



(11) **EP 3 373 356 B1**

(12) **EUROPEAN PATENT SPECIFICATION**

(45) Date of publication and mention of the grant of the patent:
08.01.2020 Bulletin 2020/02

(51) Int Cl.:
H01L 51/52^(2006.01)

(21) Application number: **18161325.8**

(22) Date of filing: **12.03.2018**

(54) **ORGANIC LIGHT-EMITTING DISPLAY APPARATUS AND METHOD OF MANUFACTURING THE SAME**

ORGANISCHE LICHEMITTIERENDE ANZEIGEVORRICHTUNG UND VERFAHREN ZUR HERSTELLUNG DAVON

APPAREIL À AFFICHAGE ÉLECTROLUMINESCENT ORGANIQUE ET SON PROCÉDÉ DE FABRICATION

(84) Designated Contracting States:
AL AT BE BG CH CY CZ DE DK EE ES FI FR GB GR HR HU IE IS IT LI LT LU LV MC MK MT NL NO PL PT RO RS SE SI SK SM TR

(30) Priority: **10.03.2017 KR 20170030811**

(43) Date of publication of application:
12.09.2018 Bulletin 2018/37

(73) Proprietor: **Samsung Display Co., Ltd. Gyeonggi-Do (KR)**

(72) Inventors:
• **CHOI, Shinil Gyeonggi-do (KR)**
• **YANG, Sunghoon Gyeonggi-do (KR)**

(74) Representative: **Mounteney, Simon James Marks & Clerk LLP 15 Fetter Lane London EC4A 1BW (GB)**

(56) References cited:
US-A1- 2015 102 305 US-A1- 2016 197 297

EP 3 373 356 B1

Note: Within nine months of the publication of the mention of the grant of the European patent in the European Patent Bulletin, any person may give notice to the European Patent Office of opposition to that patent, in accordance with the Implementing Regulations. Notice of opposition shall not be deemed to have been filed until the opposition fee has been paid. (Art. 99(1) European Patent Convention).

Description

BACKGROUND

FIELD

[0001] Embodiments of the present invention relate to an organic light-emitting display (OLED) apparatus and a method of manufacturing the same.

DISCUSSION OF THE BACKGROUND

[0002] An organic light-emitting display (OLED) apparatus is a self-emitting display apparatus that includes a hole injection electrode, an electron injection electrode, and an organic emission layer between the hole injection electrode and the electron injection electrode, and emits light when holes injected from the hole injection electrode and electrons injected from the electron injection electrode recombine in the organic emission layer. The OLED apparatus has advantages such as low power consumption, high luminance, and fast response rates, and thus has received attention as a next-generation display apparatus.

[0003] US 2016/197297 discloses an OLED apparatus and associated manufacturing method.

[0004] The above information disclosed in this Background section is only for enhancement of understanding of the background of the inventive concepts. Therefore, it may contain information that does not form the prior art that was already known to a person of ordinary skill in the art or was publically available prior to an effective filing date of subject matter disclosed herein.

SUMMARY

[0005] Embodiments of the present invention provide an organic light-emitting display (OLED) apparatus that may increase a resolution and reduce defects and manufacturing costs, and a method of manufacturing the OLED apparatus.

[0006] Additional features of the invention will be set forth in the description which follows, and in part will be apparent from the description, or may be learned by practice of the invention.

[0007] An embodiment of the present invention discloses an organic light-emitting display (OLED) apparatus as set-out in claim 1. Optional features of this aspect of the invention are set-out in claims 2 to 10.

[0008] An embodiment of the present invention also discloses an organic light-emitting display (OLED) apparatus as set-out in claim 11. Optional features of this aspect of the invention are set-out in claim 12.

[0009] An embodiment of the present invention also discloses a method of manufacturing an organic light-emitting display (OLED) apparatus as set-out in claim 13. Optional features of this aspect of the invention are set-out in claims 14 to 22.

[0010] It is to be understood that both the foregoing general description and the following detailed description are provided by way of example and are intended to provide further explanation of the invention as claimed.

BRIEF DESCRIPTION OF THE DRAWINGS

[0011] The accompanying drawings, which are included to provide a further understanding of the invention and are incorporated in and constitute a part of this specification, illustrate embodiments of the invention, and together with the description serve to explain the principles of the invention.

FIG. 1 is a schematic plan view of an organic light-emitting display (OLED) apparatus according to a first embodiment.

FIG. 2 is a plan view illustrating a portion of a display area of the OLED apparatus as illustrated in FIG. 1.

FIG. 3 is a cross-sectional view of the OLED apparatus according to the first embodiment, taken along a line III-III of FIG. 2.

FIG. 4 is a schematic cross-sectional view for explaining an operation of forming a plurality of anodes on a substrate of the OLED apparatus according to the first embodiment.

FIG. 5 is a schematic cross-sectional view for explaining an operation of forming a pixel-defining layer in the OLED apparatus according to the first embodiment.

FIGS. 6A, 6B, 6C, 6D, 6E, 6F, and 6G are schematic cross-sectional views for explaining a first unit process of forming the OLED apparatus according to the first embodiment.

FIGS. 7A, 7B, 7C, 7D, 7E, 7F, and 7G are schematic cross-sectional views for explaining a second unit process of forming the OLED apparatus according to the first embodiment.

FIGS. 8A, 8B, 8C, 8D, 8E, 8F, and 8G are schematic cross-sectional views for explaining a third unit process of forming the OLED apparatus according to the first embodiment.

FIGS. 9A, 9B, 9C, 9D, and 9E are schematic cross-sectional views for explaining a first unit process of forming an organic light-emitting display (OLED) apparatus according to a comparative example.

FIGS. 10A, 10B, 10C, 10D, and 10E are schematic cross-sectional views for explaining a second unit process of forming the OLED apparatus according to the comparative example.

FIGS. 11A, 11B, 11C, 11D, and 11E are schematic cross-sectional views for explaining a third unit process of forming the OLED apparatus according to the comparative example.

FIG. 12 is a schematic cross-sectional view of an organic light-emitting display (OLED) apparatus according to a second embodiment.

DETAILED DESCRIPTION

[0012] In the following description, for the purposes of explanation, numerous specific details are set forth in order to provide a thorough understanding of various embodiments. It is apparent, however, that various embodiments may be practiced without these specific details or with one or more equivalent arrangements. In other instances, well-known structures and devices are shown in block diagram form in order to avoid unnecessarily obscuring various embodiments.

[0013] Unless otherwise specified, the illustrated embodiments are to be understood as providing example features of varying detail. Therefore, unless otherwise specified, the features, components, modules, layers, films, panels, regions, and/or aspects of the various illustrations may be otherwise combined, separated, interchanged, and/or rearranged without departing from the disclosed invention. Further, in the accompanying figures, the size and relative sizes of layers, films, panels, regions, etc., may be exaggerated for clarity and descriptive purposes. When an embodiment may be implemented differently, a specific process order may be performed differently from the described order. For example, two consecutively described processes may be performed substantially at the same time or performed in an order opposite to the described order. Also, like reference numerals denote like elements.

[0014] When an element or layer is referred to as being "on," "connected to," or "coupled to" another element or layer, it may be directly on, connected to, or coupled to the other element or layer or intervening elements or layers may be present. When, however, an element or layer is referred to as being "directly on," "directly connected to," or "directly coupled to" another element or layer, there are no intervening elements or layers present. Further, the x-axis, the y-axis, and the z-axis are not limited to three axes of a rectangular coordinate system, and may be interpreted in a broader sense. For example, the x-axis, the y-axis, and the z-axis may be perpendicular to one another, or may represent different directions that are not perpendicular to one another. For the purposes of this disclosure, "at least one of X, Y, and Z" and "at least one selected from the group consisting of X, Y, and Z" may be construed as X only, Y only, Z only, or any combination of two or more of X, Y, and Z, such as, for instance, XYZ, XYY, YZ, and ZZ. As used herein, the term "and/or" includes any and all combinations of one or more of the associated listed items.

[0015] Although the terms "first," "second," etc. may be used herein to describe various elements, components, regions, layers, and/or sections, these elements, components, regions, layers, and/or sections should not be limited by these terms. These terms are used to distinguish one element, component, region, layer, and/or section from another element, component, region, layer, and/or section. Thus, a first element, component, region, layer, and/or section discussed below could be termed

a second element, component, region, layer, and/or section without departing from the teachings of the present disclosure.

[0016] Spatially relative terms, such as "beneath," "below," "lower," "above," "upper," and the like, may be used herein for descriptive purposes, and, thereby, to describe one element or feature's relationship to another element(s) or feature(s) as illustrated in the drawings. Spatially relative terms are intended to encompass different orientations of an apparatus in use, operation, and/or manufacture in addition to the orientation depicted in the drawings. For example, if the apparatus in the drawings is turned over, elements described as "below" or "beneath" other elements or features would then be oriented "above" the other elements or features. Thus, the term "below" can encompass both an orientation of above and below. Furthermore, the apparatus may be otherwise oriented (e.g., rotated 90 degrees or at other orientations), and, as such, the spatially relative descriptors used herein interpreted accordingly.

[0017] The terminology used herein is for the purpose of describing particular embodiments and is not intended to be limiting. As used herein, the singular forms, "a," "an," and "the" are intended to include the plural forms as well, unless the context clearly indicates otherwise. Moreover, the terms "comprises," "comprising," "includes," and/or "including," when used in this specification, specify the presence of stated features, integers, steps, operations, elements, components, and/or groups thereof, but do not preclude the presence or addition of one or more other features, integers, steps, operations, elements, components, and/or groups thereof.

[0018] Various embodiments are described herein with reference to sectional illustrations that are schematic illustrations of idealized embodiments and/or intermediate structures. As such, variations from the shapes of the illustrations as a result, for example, of manufacturing techniques and/or tolerances, are to be expected. Thus, embodiments disclosed herein should not be construed as limited to the particular illustrated shapes of regions, but are to include deviations in shapes that result from, for instance, manufacturing. For example, an implanted region illustrated as a rectangle will, typically, have rounded or curved features and/or a gradient of implant concentration at its edges rather than a binary change from implanted to non-implanted region. Likewise, a buried region formed by implantation may result in some implantation in the region between the buried region and the surface through which the implantation takes place. Thus, the regions illustrated in the drawings are schematic in nature and their shapes are not intended to illustrate the actual shape of a region of a device and are not intended to be limiting.

[0019] Unless otherwise defined, all terms (including technical and scientific terms) used herein have the same meaning as commonly understood by one of ordinary skill in the art to which this disclosure is a part. Terms, such as those defined in commonly used dictionaries,

should be interpreted as having a meaning that is consistent with their meaning in the context of the relevant art and will not be interpreted in an idealized or overly formal sense, unless expressly so defined herein

[0020] FIG. 1 is a schematic plan view of an organic light-emitting display (OLED) apparatus 1 according to a first embodiment. FIG. 2 is a plan view illustrating a portion of a display area DA of the OLED apparatus as illustrated in FIG. 1. FIG. 3 is a cross-sectional view of the OLED apparatus 1 of FIG. 1, taken along a line III-III of FIG. 2.

[0021] Referring to FIG. 1, the OLED apparatus 1 includes a substrate 100. The substrate 100 includes a display area DA and a peripheral area PA outside the display area DA.

[0022] In the display area DA of the substrate 100, pixels P including organic light-emitting devices (OLED) may be arranged. The peripheral area PA of the substrate 100 is an area where an image is not implemented and various wires for transmitting electrical signals to the display area DA are located in the peripheral area PA.

[0023] Referring to FIGS. 2 and 3, the display area DA includes pixels P1, P2, and P3 emitting light of different colors. Hereinafter, for convenience, the pixels P1, P2, and P3 emitting light of different colors are referred to as a first pixel P1, a second pixel P2, and a third pixel P3.

[0024] According to an embodiment, the first pixel P1 emits red light, the second pixel P2 emits green light, and the third pixel P3 emits blue light. In the present embodiment, three pixels, that is, the first, second, and third pixels P1, P2, and P3, are arranged in the display area DA. However, the embodiments are not limited thereto. In an embodiment, the display area DA may further include a fourth pixel (not shown) emitting white light in addition to the first, second, and third pixels P1, P2, and P3.

[0025] A first anode (or a first electrode) 101, a second anode (or a second electrode) 102, and a third anode (or a third electrode) 103 are respectively disposed in the first, second, and third pixels P1, P2, and P3 on the substrate 100 and are spaced apart from each other.

[0026] A pixel-defining layer 110 covers end portions of the first, second, and third anodes 101, 102, and 103.

[0027] A first organic functional layer 141 including a first emission layer, a second organic functional layer 142 including a second emission layer, and a third organic functional layer 143 including a third emission layer are respectively disposed on the first, second, and third anodes 101, 102, and 103. A first auxiliary cathode (or a first opposing electrode) 150, a second auxiliary cathode 160 (or a second opposing electrode), and a third auxiliary cathode 170 (or a third opposing electrode) are respectively disposed on the first, second, and third organic functional layers 141, 142, and 143.

[0028] The first auxiliary cathode 150 includes a first conductive layer 181 disposed on the first organic functional layer 141, a second conductive layer 182 covering side surfaces of the first organic functional layer 141, a

fourth conductive layer 184 covering side surfaces of the second conductive layer 182, and a sixth conductive layer 186 covering side surfaces of the fourth conductive layer 184. Thus, an area S(150) of the first auxiliary cathode 150 is greater than an area S(101) of the first anode 101 in the plan view.

[0029] The second auxiliary cathode 160 includes a third conductive layer 183 disposed on the second organic functional layer 142, the fourth conductive layer 184 covering side surfaces of the second organic functional layer 142, and the sixth conductive layer 186 covering side surfaces of the fourth conductive layer 184. Thus, an area S(160) of the second auxiliary cathode 160 is greater than an area S(102) of the second anode 102 in the plan view.

[0030] The third auxiliary cathode 170 includes a fifth conductive layer 185 disposed on the third organic functional layer 143, and the sixth conductive layer 186 covering side surfaces of the third organic functional layer 143. Thus, an area S(170) of the third auxiliary cathode 170 is greater than an area S(103) of the third anode 103 in the plan view.

[0031] First, second, third, fourth, fifth, and sixth conductive layers 181, 182, 183, 184, 185, and 186 may include metallic materials.

[0032] A sum of a lateral thickness T2 of the second conductive layer 182, a lateral thickness T4 of the fourth conductive layer 184, and a lateral thickness T6 of the sixth conductive layer 186 is a lateral thickness L1 of the first auxiliary cathode 150. A sum of the lateral thickness T4 of the fourth conductive layer 184 and the lateral thickness T6 of the sixth conductive layer 186 is a lateral thickness L2 of the second auxiliary cathode 160. The lateral thickness T6 of the sixth conductive layer 186 is equal to a lateral thickness L3 of the third auxiliary cathode 170. That is, the lateral thickness L1 of a portion of the first auxiliary cathode 150 disposed on a side surface of the first organic functional layer 141 is greater than the lateral thickness L2 of a portion of the second auxiliary cathode 160 disposed on a side surface of the second organic functional layer 142. The lateral thickness L2 of a portion of the second auxiliary cathode 160 disposed on the side surface of the second organic functional layer 142 is greater than the lateral thickness L3 of a portion of the third auxiliary cathode 170 disposed on a side surface of the third organic functional layer 143.

[0033] With reference to FIGS. 4, 5, 6A, 6B, 6C, 6D, 6E, 6F, 6G, 7A, 7B, 7C, 7D, 7E, 7F, 7G, 8A, 8B, 8C, 8D, 8E, 8F, and 8G, a method of manufacturing the OLED apparatus 1 according to the present exemplary embodiment and the OLED apparatus 1 manufactured by the above method are described in more detail.

[0034] FIG. 4 is a schematic cross-sectional view for explaining an operation of forming the first, second, and third anodes 101, 102, and 103 on the substrate 100 of the OLED apparatus 1 according to the first embodiment. FIG. 5 is a schematic cross-sectional view for explaining an operation of forming a pixel-defining layer 110 in the

OLED apparatus 1 according to the first embodiment. FIGS. 6A to 6G are schematic cross-sectional views for explaining a first unit process of the OLED apparatus 1 according to the first embodiment. FIGS. 7A to 7G are schematic cross-sectional views for explaining a second unit process of the OLED apparatus 1 according to the first embodiment. FIGS. 8A to 8G are schematic cross-sectional views for explaining a third unit process of the OLED apparatus 1 according to the first embodiment.

[0035] Referring to FIG. 4, the first anode 101, the second anode 102, and the third anode 103 are formed on the substrate 100.

[0036] The substrate 100 may include various materials. For example, the substrate 100 may include glass or plastic. Examples of the plastic may include materials having excellent heat resistance and excellent durability such as polyimide, polyethylene naphthalate, polyethylene terephthalate, polyarylate, polycarbonate, polyetherimide, and polyethersulfone.

[0037] Additionally, a buffer layer for planarizing a top surface of the substrate 100 and preventing or reducing penetration of impurities may be further formed over the substrate 100. For example, the buffer layer may be a layer or layers including silicon nitride, silicon oxide, and/or the like.

[0038] The first, second, and third anodes 101, 102, and 103 may be hole injection electrodes and include materials having a high work function. The first, second, and third anodes 101, 102, and 103 may each include a transparent conductive oxide component. For example, the first, second, and third anodes 101, 102, and 103 may include at least one of indium tin oxide, indium zinc oxide, zinc oxide, indium oxide, indium gallium oxide, and aluminum zinc oxide. Also, the first, second, and third anodes 101, 102, and 103 may each be a layer or layers including a metal such as silver (Ag), aluminum (Al), magnesium (Mg), lithium (Li), or calcium (Ca) and/or an alloy.

[0039] The first, second, and third anodes 101, 102, and 103 electrically contact first, second, and third thin-film transistors, respectively, wherein the first, second, and third thin-film transistors are disposed between the substrate 100 and the first, second, and third anodes 101, 102, and 103, respectively.

[0040] Referring to FIG. 5, the pixel-defining layer 110 surrounding edges of the first anode 101, the second anode 102, and the third anode 103 is formed on the substrate 100.

[0041] Since edges of the first, second, and third anodes 101, 102, and 103 are sharp, when a current is applied after the first, second, and third auxiliary cathodes 150, 160, and 170 are formed, an electric field may be concentrated in the edges of the first, second, and third anodes 101, 102 and 103, and thus an electrical short circuit may occur during operation. However, in the present embodiment, the end portions of the first, second, and third anodes 101, 102, and 103 are covered by the pixel-defining layer 110, and thus an electric field may be prevented or reduced from concentrating in the end

portions of the first, second, and third anodes 101, 102, and 103.

[0042] The pixel-defining layer 110 may be an organic insulating layer including, for example, a general-purpose polymer such as poly(methyl methacrylate) (PMMA) or polystyrene (PS), a polymer derivative having a phenol group, an acryl-based polymer, an imide-based polymer, an aryl ether-based polymer, an amide-based polymer, a fluorine-based polymer, a p-xylene-based polymer, a vinyl alcohol-based polymer, or a combination thereof.

[0043] Referring to FIG. 6A, the first organic functional layer 141 and the first conductive layer 181 are sequentially deposited on the substrate 100 on which the first, second, and third anodes 101, 102, and 103 are formed.

[0044] The first organic functional layer 141 includes a first emission layer. Also, the first organic functional layer 141 may further include at least one functional layer including a hole injection layer, a hole transport layer, an electron transport layer, and an electron injection layer.

[0045] The first organic functional layer 141 may be formed by a vacuum deposition method. During a deposition process, the first organic functional layer 141 is formed on top surfaces of the first, second, and third anodes 101, 102, and 103 and on the pixel-defining layer 110.

[0046] The first conductive layer 181 may be formed on the first organic functional layer 141 by a vacuum deposition method. The first conductive layer 181 may include Ag, Mg, Al, platinum (Pt), palladium (Pd), gold (Au), nickel (Ni), neodymium (Nd), iridium (Ir), chromium (Cr), Li, Ca, or an alloy thereof. The first conductive layer 181 may also include a transparent conductive material.

[0047] Referring to FIG. 6B, a first photoresist 131 is disposed on the first conductive layer 181. The first photoresist 131 is exposed to light using a first photomask M1 including an area M11 through which light L passes and an area M12 where light L is blocked.

[0048] Referring to FIG. 6C, the first photoresist 131 is developed. The first photoresist 131 may be either a positive type or a negative type. In the present embodiment, the first photoresist 131 is a positive type. A first portion 131-1 of the developed first photoresist 131, which corresponds to the first anode 101, is formed as a pattern, and the rest of the first photoresist 131 is removed.

[0049] Referring to FIG. 6D, the first portion 131-1 of the first photoresist 131 of FIG. 6C is used as an etch mask, and the first organic functional layer 141 and the first conductive layer 181 are etched and patterned.

[0050] The first organic functional layer 141 and the first conductive layer 181 may be etched by a dry etching process. The dry etching process may be respectively performed on the first organic functional layer 141 and the first conductive layer 181. For example, the first conductive layer 181 may be dry-etched by using a gas including fluorine F or chlorine Cl, and then the first organic functional layer 141 may be dry-etched by using oxygen

gas.

[0051] Referring to FIG. 6E, the first portion 131-1 (see FIG. 6D) of the first photoresist 131 is removed. The first portion 131-1 of the first photoresist 131 may be removed by a dry process such as ashing or stripping.

[0052] As the first portion 131-1 of the first photoresist 131 is removed, the first organic functional layer 141 and the first conductive layer 181 are formed as patterns over the first anode 101.

[0053] Referring to FIG. 6F, the second conductive layer 182 is deposited on the structure illustrated in FIG. 6E.

[0054] The second conductive layer 182 may include the same material as or a different material from the above-described first conductive layer 181. The second conductive layer 182 covers a top surface 181-T of the first conductive layer 181 as well as side surfaces 141-S of the first organic functional layer 141 and side surfaces 181-S of the first conductive layer 181.

[0055] Referring to FIG. 6G, the second conductive layer 182 is patterned such that portions of the second conductive layer 182, which cover the side surfaces 141-S of the first organic functional layer 141 and the side surfaces 181-S of the first conductive layer 181, is formed at a location corresponding to the first anode 101, and the rest of the second conductive layer 182 is removed.

[0056] The second conductive layer 182 may be patterned by a dry etching method. The second conductive layer 182 may be dry-etched by using a gas including F or Cl. By performing the dry etching method which does not use a solvent, damage to the first organic functional layer 141 due to the solvent may be prevented or reduced, and by performing anisotropic etching, the second conductive layer 182 may only be disposed along the side surfaces 181-S of the first conductive layer 181, without increasing a thickness of the first conductive layer 181 from the top surface 181-T thereof.

[0057] Also, the top surface 141-T of the first organic functional layer 141 is covered by the first conductive layer 181, and the side surfaces 141-S thereof are surrounded by the second conductive layer 182, thereby preventing or reducing deterioration of the first organic functional layer 141 which may be caused by a subsequent process.

[0058] After the first unit process is performed, the second unit process for forming the second organic functional layer 142 is performed at a location where the second anode 102 is disposed, the second organic functional layer 142 emitting light of a different color from the first organic functional layer 141. Hereinafter, the second unit process is described with reference to FIGS. 7A, 7B, 7C, 7D, 7E, 7F, and 7G.

[0059] Referring to FIG. 7A, the second organic functional layer 142 and the third conductive layer 183 are sequentially deposited on the structure illustrated in FIG. 6G.

[0060] The second organic functional layer 142 may include a second emission layer that emits light of a different color from the first emission layer. Also, the second

organic functional layer 142 may further include at least one functional layer including a hole injection layer, a hole transport layer, an electron transport layer, and an electron injection layer. The second organic functional layer 142 may be formed by a vacuum deposition method.

[0061] The third conductive layer 183 may be formed on the second organic functional layer 142 by a vacuum deposition method. The third conductive layer 183 may include the same material as or a different material from the first conductive layer 181. The third conductive layer 183 may also include the same material as or a different material from the second conductive layer 182.

[0062] Referring to FIG. 7B, a second photoresist 132 is disposed on the third conductive layer 183. The second photoresist 132 is exposed to light using a second photomask M2 including an area M21 through which light L passes and an area M22 where light L is blocked.

[0063] Referring to FIG. 7C, the second photoresist 132 is developed. The second photoresist 132 may be either a positive type or a negative type. In the present embodiment, the second photoresist 132 is a positive type. A first portion 132-1 of the developed second photoresist 132 is formed as a pattern and corresponds to the second anode 102. The rest of the second photoresist 132 is removed.

[0064] Referring to FIG. 7D, the second organic functional layer 142 and the third conductive layer 183 are etched and patterned by using the first portion 132-1 of the second photoresist 132 of FIG. 7C as an etch mask.

[0065] The second organic functional layer 142 and the third conductive layer 183 may be etched by a dry etching process. The dry etching process may be respectively performed on the second organic functional layer 142 and the third conductive layer 183. For example, the third conductive layer 183 may be dry-etched by using a gas including F or Cl, and then the second organic functional layer 142 may be dry-etched by using oxygen gas.

[0066] Referring to FIG. 7E, the first portion 132-1 (see FIG. 7D) of the second photoresist 132 is removed. The first portion 132-1 of the second photoresist 132 may be removed by a dry process such as ashing or stripping.

[0067] As the first portion 132-1 of the second photoresist 132 is removed, the second organic functional layer 142 and the third conductive layer 183 are formed as patterns over the second anode 102.

[0068] Referring to FIG. 7F, the fourth conductive layer 184 is deposited on the structure illustrated in FIG. 7E.

[0069] The fourth conductive layer 184 may include the same material as or a different material from the above-described third conductive layer 183. The fourth conductive layer 184 covers a top surface 183-T of the third conductive layer 183 over the second anode 102 as well as side surfaces 142-S of the second organic functional layer 142 and side surfaces 183-S of the third conductive layer 183.

[0070] The fourth conductive layer 184 covers the top surface 181-T of the first conductive layer 181 over the

first anode 101 as well as the side surfaces 182-S of the second conductive layer 182.

[0071] Referring to FIG. 7G, the fourth conductive layer 184 is patterned such that portions of the fourth conductive layer 184, which cover the side surfaces 182-S of the second conductive layer 182, are formed at a location corresponding to the first anode 101, portions of the fourth conductive layer 184, which cover the side surfaces 142-S of the second organic functional layer 142 and the side surfaces 183-S of the third conductive layer 183, are formed at a location corresponding to the second anode 102, and the rest of the fourth conductive layer 184 is removed.

[0072] The fourth conductive layer 184 is patterned by a dry etching method. The fourth conductive layer 184 may be dry-etched by using a gas including F or Cl. By performing the dry etching method which does not use a solvent, damage to the second organic functional layer 142 due to the solvent may be prevented or reduced, and by performing anisotropic etching, the fourth conductive layer 184 may only be disposed along the side surfaces 182-S of the second conductive layer 182 and the side surfaces 183-S of the third conductive layer 183, without increasing respective thicknesses of the first conductive layer 181 and the third conductive layer 183 from the top surfaces 181-T and 183-T thereof.

[0073] Also, a top surface of the second organic functional layer 142 is covered by the third conductive layer 183, and the side surfaces 142-S of the second organic functional layer 142 are surrounded by the fourth conductive layer 184, thereby preventing or reducing deterioration of the second organic functional layer 142 which may be caused by a subsequent process.

[0074] After the above-described second unit process is performed, a third unit process of forming the third organic functional layer 143 is performed at a location where the third anode 103 is disposed, wherein the third organic functional layer 143 emits light of a different color from the first organic functional layer 141 and the second organic functional layer 142. The third unit process is described with reference to FIGS. 8A to 8G.

[0075] Referring to FIG. 8A, the third organic functional layer 143 and the fifth conductive layer 185 are sequentially deposited on the structure illustrated in FIG. 7G.

[0076] The third organic functional layer 143 may include a third emission layer that emits light of a different color from the first emission layer (not shown) and the second emission layer. The third organic functional layer 143 may further include at least one functional layer including a hole injection layer, a hole transport layer, an electron transport layer, and an electron injection layer. The third organic functional layer 143 may be formed by a vacuum deposition method.

[0077] The fifth conductive layer 185 may be formed on the third organic functional layer 143 by a vacuum deposition method. The fifth conductive layer 185 may include the same material as or a different material from the third conductive layer 183. Also, the fifth conductive

layer 185 may include the same material as or a different material from the fourth conductive layer 184.

[0078] Referring to FIG. 8B, a third photoresist 133 is disposed on the fifth conductive layer 185. The third photoresist 133 is exposed to light using a third photomask M3 including an area M31 through which light L passes and an area M32 where light L is blocked.

[0079] Referring to FIG. 8C, the third photoresist 133 is developed. The third photoresist 133 may be of either a positive type or a negative type. In the present embodiment, the third photoresist 133 is of a positive type. A first portion 133-1 of the developed third photoresist 133 is formed as a pattern at a location corresponding to the third anode 103, and the rest thereof is removed.

[0080] Referring to FIG. 8D, the third organic functional layer 143 and the fifth conductive layer 185 are etched and then patterned using the first portion 133-1 of the third photoresist 133 of FIG. 8C as an etch mask.

[0081] The third organic functional layer 143 and the fifth conductive layer 185 may be etched by a dry etching process. The dry etching process may be respectively performed on the third organic functional layer 143 and the fifth conductive layer 185. For example, after the fifth conductive layer 185 is dry-etched by using a gas including F or Cl, the third organic functional layer 143 may be dry-etched by using oxygen gas.

[0082] Referring to FIG. 8E, the first portion 133-1 (see FIG. 8D) of the third photoresist 133 is removed. The first portion 133-1 of the third photoresist 133 may be removed by dry process such as ashing or stripping.

[0083] As the first portion 133-1 of the third photoresist 133 is removed, the third organic functional layer 143 and the fifth conductive layer 185 are formed as patterns over the third anode 103.

[0084] Referring to FIG. 8F, the sixth conductive layer 186 is deposited on the structure illustrated in FIG. 8E.

[0085] The sixth conductive layer 186 may include the same material as or a different material from the above-described fifth conductive layer 185.

[0086] The sixth conductive layer 186 covers a top surface 185-T of the fifth conductive layer 185 as well as side surfaces 143-S of the third organic functional layer 143 and side surfaces 185-S of the fifth conductive layer 185 over the third anode 103. The sixth conductive layer 186 covers the top surface 181-T of the first conductive layer 181 as well as the side surfaces 184-S of the fourth conductive layer 184 over the first anode 101. In addition, the sixth conductive layer 186 covers the top surface 183-T of the third conductive layer 183 as well as the side surfaces 184-S of the fourth conductive layer 184 over the second anode 102.

[0087] Referring to FIG. 8G, the sixth conductive layer 186 is patterned such that portions of the sixth conductive layer 186, which cover the side surfaces 184-S of the fourth conductive layer 184, are formed at a location corresponding to the first anode 101, portions of the sixth conductive layer 186, which cover the side surfaces 184-S of the fourth conductive layer 184, are formed at a

location corresponding to the second anode 102, portions of the sixth conductive layer 186, which cover the side surfaces 143-S of the third organic functional layer 143 and the side surfaces 185-S of the fifth conductive layer 185, are formed at a location corresponding to the third anode 103, and the rest of the sixth conductive layer 186 is removed.

[0088] The sixth conductive layer 186 is patterned by a dry etching method. The sixth conductive layer 186 may be dry-etched by using a gas including F or Cl. By performing the dry etching method which does not use a solvent, damage to of the third organic functional layer 143 due to the solvent may be prevented or reduced, and by performing anisotropic etching, the sixth conductive layer 186 may only disposed along the side surfaces 184-S of the fourth conductive layer 184 and the side surfaces 185-S of the fifth conductive layer 185, without increasing respective thicknesses of the first, third, and fifth conductive layers 181, 183, and 185 from the top surfaces 181-T, 183-T, and 185-T thereof.

[0089] According to the first, second, and third unit processes, in the first auxiliary cathode 150 (see FIG. 3), the second conductive layer 182, the fourth conductive layer 184, and the sixth conductive layer 186 are formed adjacent to outer portions or edges of the first conductive layer 181. In the second auxiliary cathode 160 (see FIG. 3), the fourth conductive layer 184 and the sixth conductive layer 186 are formed adjacent to outer portions or edges of the third conductive layer 183, and in the third auxiliary cathode 170 (see FIG. 3), the sixth conductive layer 186 is formed on outer portions or edges of the fifth conductive layer 185. Thus, an area of the first auxiliary cathode 150 in plan view is greater than an area of the second auxiliary cathode 160 in plan view, and the area of the second auxiliary cathode 160 in plan view is greater than an area of the third auxiliary cathode 170 in plan view.

[0090] The top surface of the third organic functional layer 143 is covered by the fifth conductive layer 185, and the side surfaces 143-S of the third organic functional layer 143 are surrounded by the sixth conductive layer 186, thereby preventing or reducing deterioration of the third organic functional layer 143 that may be caused by a subsequent process.

[0091] FIG. 12 is a schematic cross-sectional view of an organic light-emitting display (OLED) apparatus 2 according to a second embodiment.

[0092] Referring to FIG. 12, unlike the OLED apparatus 1 of FIG. 1, the OLED apparatus 2 further includes a cathode 180. The cathode 180 is integrally formed as a common electrode on the top surfaces and the side surfaces of the first, second, and third auxiliary cathodes 150, 160, and 170.

[0093] The cathode 180 may include the same material as or a different material from the first, second, and third auxiliary cathodes 150, 160, and 170. As described above, the first, second, and third auxiliary cathodes 150, 160, and 170 surround the side surfaces of the first, sec-

ond, and third organic functional layers 141, 142, and 143 and function as barriers preventing or reducing penetration of external oxygen and moisture into the first, second, and third organic functional layers 141, 142, and 143, during the first, second, and third unit processes. The cathode 180, which is a common electrode, is deposited again on the first, second, and third organic functional layers 141, 142, and 143 so as to protect the first, second, and third organic functional layers 141, 142, and 143 and decrease a voltage drop resulting from cathode resistance.

[0094] In the present embodiment, the first, second, and third anodes 101, 102, and 103 are described as hole injection electrodes, and the first, second, and third auxiliary cathodes 150, 160, and 170 are described as electron injection electrodes. However, these descriptions are merely examples, and the embodiments are not limited thereto. Electron injection electrodes may be formed respectively at locations where the first, second, and third anodes 101, 102, and 103 are disposed, and hole injection electrodes may be formed respectively at locations where the first, second, and third auxiliary cathodes 150, 160, and 170 and the cathode 180 are disposed.

[0095] During a process of depositing an organic functional layer using a metal mask in which an opening is formed, it is difficult to apply the metal mask to an ultra-high-definition display panel because it is difficult to precisely process the metal mask due to a thickness and alignment tolerance thereof, and also it is difficult to increase the size of the metal mask due to deflection caused by a weight of the metal mask. However, according to the present embodiment, patterns of the first, second, and third organic functional layers 141, 142, and 143 are formed by a dry process and a photolithography process, not by a deposition process using a metal mask, and thus problems that may be caused by using a metal mask may be solved.

[0096] In the present embodiment, an organic functional layer and an auxiliary cathode are formed by a photolithography process and a dry process instead of a process of using an expensive fluorine-based resin or solvent, and thus manufacturing costs may be reduced by reducing costs of an expensive fluorine-based resin coating.

[0097] Hereinafter, a method of manufacturing an organic light-emitting display (OLED) apparatus according to a comparative example is described with reference to FIGS. 9A to 9E.

[0098] FIGS. 9A, 9B, 9C, 9D, and 9E are schematic cross-sectional views for explaining a first unit process of forming an OLED apparatus according to a comparative example. FIGS. 10A, 10B, 10C, 10D, and 10E are schematic cross-sectional views for explaining a second unit process of forming the OLED apparatus according to the comparative example. FIGS. 11A, 11B, 11C, 11D, and 11E are schematic cross-sectional views for explaining a third unit process of forming the OLED apparatus according to the comparative example.

[0099] Referring to FIG. 9A, a first lift-off layer 121 including a fluoropolymer is formed over the substrate 100 on which the first, second, and third anodes 101, 102, and 103 and the pixel-defining layer 110 covering end portions or edges of the first, second, and third anodes 101, 102, and 103 are formed. Then, the first photoresist 131 is formed on the first lift-off layer 121.

[0100] Referring to FIG. 9B, the first photoresist 131 is patterned. The first photoresist 131 is exposed and developed and then the first portion 131-1 corresponding to the first anode 101 is removed therefrom, and a second portion 131-2 other than the first portion 131-1 is formed.

[0101] Referring to FIG. 9C, the first lift-off layer 121 is etched by using a pattern of the first photoresist 131 of FIG. 9B as an etch mask and using a first solvent including fluorine (F). During the etching process, a portion of the first lift-off layer 121 disposed on the first anode 101 at a location corresponding to the first portion 131-1 is etched. The first lift-off layer 121 is etched to form a first undercut profile UC1 under a surface of a boundary of the first portion 131-1 of the first photoresist 131.

[0102] Referring to FIG. 9D, the first organic functional layer 141 and the first conductive layer 181 are sequentially formed over the structure illustrated in FIG. 9C.

[0103] Referring to FIG. 9E, a first lift-off process is performed to entirely remove all remaining portions of the first lift-off layer 121, and accordingly, the first organic functional layer 141 and the first conductive layer 181 are formed as patterns over the first anode 101. In this case, the side surfaces 141-S of the first organic functional layer 141 and the side surfaces 181-S of the first conductive layer 181 are exposed.

[0104] After the first unit process is completed, the second unit process is performed.

[0105] Referring to FIG. 10A, a second lift-off layer 122 and the second photoresist 132 are sequentially formed over the structure illustrated in FIG. 9E.

[0106] The second lift-off layer 122 includes a fluoropolymer. The fluoropolymer is electrochemically stable due to its low interaction with other materials, but when the second lift-off layer 122 contacts the side surfaces 141-S of the first organic functional layer 141, the first organic functional layer 141 may be deteriorated.

[0107] Referring to FIG. 10B, the second photoresist 132 is exposed and developed. The second photoresist 132 is patterned such that the first portion 132-1 corresponding to the second anode 102 is removed and a second portion 132-2 other than the first portion 132-1 is formed.

[0108] Referring to FIG. 10C, the second lift-off layer 122 is etched by using a pattern of the second photoresist 132 of FIG. 10B as an etch mask and using the first solvent including fluorine (F). During the etching process, a portion of the second lift-off layer 122 disposed on the second anode 102 at a location corresponding to the first portion 132-1 is etched. The second lift-off layer 122 is etched to form a second undercut profile UC2 under a surface of a boundary of the first portion 132-1 of the

second photoresist 132.

[0109] During a wet etching process using the first solvent, the first solvent is absorbed by the second lift-off layer 122, and thus delivered to the first organic functional layer 141 through the side surfaces 141-S of the first organic functional layer 141.

[0110] Referring to FIG. 10D, the second organic functional layer 142 and the third conductive layer 183 are sequentially formed over the structure illustrated in FIG. 10C.

[0111] Referring to FIG. 10E, the second lift-off process is performed to entirely remove all remaining portions of the second lift-off layer 122, and accordingly the first organic functional layer 141 and the first conductive layer 181 are formed as patterns over the first anode 101, and the second organic functional layer 142 and the third conductive layer 183 are formed as patterns over the second anode 102.

[0112] In this case, the side surfaces 141-S of the first organic functional layer 141 and the side surfaces 181-S of the first conductive layer 181 are exposed. In addition, the side surfaces 142-S of the second organic functional layer 142 and the side surface 183-S of the third conductive layer 183 are exposed.

[0113] After the second unit process is completed, the third unit process is performed.

[0114] Referring to FIG. 11A, a third lift-off layer 123 and a third photoresist 133 are sequentially formed over the structure illustrated in FIG. 10E.

[0115] The third lift-off layer 123 includes a fluoropolymer. The fluoropolymer is electrochemically stable due to its low interaction with other materials, but when the third lift-off layer 123 contacts the side surfaces 141-S of the first organic functional layer 141 and the side surfaces 142-S of the second organic functional layer 142, the first organic functional layer 141 and the second organic functional layer 142 may be deteriorated.

[0116] Referring to FIG. 11B, the third photoresist 133 is exposed and developed. The third photoresist 133 is patterned such that the first portion 133-1 corresponding to the third anode 103 is removed therefrom and a second portion 133-2 other than the first portion 133-1 is formed.

[0117] Referring to FIG. 11C, the third lift-off layer 123 is etched by using a pattern of the third photoresist 133 of FIG. 11B as an etch mask and using the first solvent including fluorine (F). The third lift-off layer 123 is etched to form a third undercut profile UC3 under a surface of a boundary of the first portion 133-1 of the third photoresist 133. During the wet etching process using the first solvent, the first solvent may be absorbed by the third lift-off layer 123, and thus may be delivered to the first organic functional layer 141 and the second organic functional layer 142 through the side surfaces 141-S of the first organic functional layer 141 and the side surfaces 142-S of the second organic functional layer 142.

[0118] Referring to FIG. 11D, the third organic functional layer 143 and the fifth conductive layer 185 are sequentially formed over the structure illustrated in FIG.

11C.

[0119] Referring to FIG. 11E, the third lift-off process is performed to entirely remove all remaining portions of the third lift-off layer 123, and accordingly, the first organic functional layer 141 and the first conductive layer 181 over the first anode 101, the second organic functional layer 142 and the third conductive layer 183 over the second anode 102, and the third organic functional layer 143 and the fifth conductive layer 185 over the third anode 103 are formed as patterns.

[0120] In this case, the side surfaces 141-S of the first organic functional layer 141 and the side surfaces 181-S of the first conductive layer 181 are exposed. In addition, the side surfaces 142-S of the second organic functional layer 142 and the side surfaces 183-S of the third conductive layer 183 are exposed. Moreover, the side surfaces 143-S of the third organic functional layer 143 and the side surfaces 185-S of the fifth conductive layer 185 are exposed.

[0121] That is, according to the method of manufacturing the OLED apparatus according to the comparative example of FIGS. 9A-11E, the side surfaces 141-S, 142-S, and 143-S of the first, second, and third organic functional layers 141, 142, and 143 are exposed during the first, second, and third unit processes such that the first, second, and third organic functional layers 141, 142, and 143 may be damaged due to a lift-off layer and a solvent, and as the first, second, and third lift-off processes are repeated, manufacturing costs may increase due to an increase in the use of expensive fluorine-based resin.

[0122] Although not illustrated in the drawings, the above-described OLED apparatuses may further include an encapsulation member that encapsulates an organic emission layer. The encapsulation member may include a glass substrate, a metal foil, and a thin-film encapsulation layer in which an inorganic layer and an organic layer are combined.

[0123] According to the above embodiments, since an emission layer is formed without using a fine metal mask (FMM), a high-resolution display panel may be formed.

[0124] Also, according to an embodiment, dry etching is performed instead of lift-off processing in which fluorine-based resin and a fluorine-based solvent are used, and thus damage to an organic functional layer due to the fluorine-based resin and the fluorine-based solvent may decrease such that a yield may be improved.

[0125] In addition, according to an embodiment, manufacturing costs may be reduced without using expensive fluorine-based resin.

[0126] It should be understood that embodiments described herein should be considered in a descriptive sense only and not for purposes of limitation. Descriptions of features or aspects within each embodiment should typically be considered as available for other similar features or aspects in other embodiments.

[0127] While one or more embodiments have been described with reference to the figures, it will be understood by those of ordinary skill in the art that various changes

in form and details may be made therein without departing from the scope of the invention as defined by the following claims.

Claims

1. An organic light-emitting display (OLED) apparatus (1) comprising a first pixel (P1) and a second pixel (P2), wherein the first pixel (P1) comprises:

a first electrode (101);
a first organic functional layer (141) disposed on the first electrode (101), the first organic functional layer (141) comprising a first emission layer; and
a first opposing electrode (150) covering a top surface and side surfaces of the first organic functional layer (141);
and wherein the second pixel (P2) comprises:

a second electrode (102) disposed separate from the first electrode (101);
a second organic functional layer (142) disposed on the second electrode (102), the second organic functional layer (142) comprising a second emission layer; and
a second opposing electrode (160) covering a top surface and side surfaces of the second organic functional layer (142);
wherein, in a lateral direction of the OLED apparatus (1), a thickness of a portion of the first opposing electrode (150) disposed on a side surface of the first organic functional layer (141) is greater than a thickness of a portion of the second opposing electrode (160) disposed on a side surface of the second organic functional layer (142).

2. An OLED apparatus according to claim 1, wherein a first color of light emitted from the first emission layer is different from a second color of light emitted from the second emission layer.

3. An OLED apparatus according to claim 1 or 2, wherein each of the first organic functional layer and the second organic functional layer comprises at least one layer selected from the group consisting of a hole injection layer, a hole transport layer, an electron injection layer, and an electron transport layer.

4. An OLED apparatus according to claim 1, 2 or 3, wherein a thickness of a portion of the first opposing electrode covering the top surface of the first organic functional layer is the same as a thickness of a portion of the second opposing electrode covering the top surface of the second organic functional layer.

5. An OLED apparatus according to any preceding claim, further comprising a pixel-defining layer comprising an insulating layer, the pixel-defining layer covering an edge of the first electrode and an edge of the second electrode. 5
6. An OLED apparatus according to claim 5, wherein an edge of the first organic functional layer and an edge of the second organic functional layer are disposed on an inclined surface of the pixel-defining layer. 10
7. An OLED apparatus according to any preceding claim, further comprising a common electrode that is commonly and integrally disposed on the first opposing electrode and the second opposing electrode. 15
8. An OLED apparatus according to claim 7, wherein the common electrode covers side surfaces of the first opposing electrode and side surfaces of the second opposing electrode. 20
9. An OLED apparatus according to any preceding claim, further comprising a third pixel, wherein the third pixel comprises: 25
- a third electrode disposed separate from the first electrode and the second electrode;
 - a third organic functional layer disposed on the third electrode, the third organic functional layer comprising a third emission layer; and
 - a third opposing electrode covering a top surface and side surfaces of the third organic functional layer;
- wherein, in a lateral direction of the OLED apparatus, the said thickness of the portion of the second opposing electrode that is disposed on the side surface of the second organic functional layer is greater than a thickness of a portion of the third opposing electrode disposed on a side surface of the third organic functional layer. 30
10. An OLED apparatus according to claim 9, wherein a first color of light emitted from the first emission layer, a second color of light emitted from the second emission layer, and a third color of light emitted from the third emission layer are different from one another. 35
11. An organic light-emitting display (OLED) apparatus comprising first (P1) and second pixels (P2), wherein the first pixel (P1) comprises: 40
- a first electrode (101);
 - a first organic functional layer (141) disposed on the first electrode (101), the first organic functional layer (141) comprising a first emission layer;
- and
- a first opposing electrode (150) covering a top surface and side surfaces of the first organic functional layer (141);
- and wherein the second pixel (p2) comprises: 45
- a second electrode (102) disposed separate from the first electrode (101);
 - a second organic functional layer (142) disposed on the second electrode (102), the second organic functional layer (142) comprising a second emission layer; and
 - a second opposing electrode (160) covering a top surface and side surfaces of the second organic functional layer;
- wherein an area of the first opposing electrode (150) in plan view is greater than an area of the second opposing electrode (160) in plan view. 50
12. An OLED apparatus according to claim 11, wherein the first opposing electrode comprises a first conductive layer covering the top surface of the first organic functional layer, a second conductive layer surrounding the side surfaces of the first organic functional layer, a fourth conductive layer surrounding side surfaces of the second conductive layer, and a sixth conductive layer surrounding side surfaces of the fourth conductive layer, and 55
- wherein the second opposing electrode comprises a third conductive layer covering the top surface of the second organic functional layer, the fourth conductive layer surrounding the side surfaces of the second organic functional layer, and the sixth conductive layer surrounding the side surfaces of the fourth conductive layer.
13. A method of manufacturing an organic light-emitting display (OLED) apparatus that comprises a first pixel (P1) that includes a first electrode (101) and a first organic functional layer (141), and comprises a second pixel (P2) that includes a second electrode (102) and a second organic functional layer (142), the method comprising: 60
- disposing the first electrode (101) and the second electrode (102) separate from each other on a substrate;
 - sequentially disposing the first organic functional layer (141) and a first conductive layer (181) over the first electrode (101);
 - patterning the first organic functional layer (141) and the first conductive layer (181) such that side surfaces of the first organic functional layer and side surfaces of the first conductive layer (181) are exposed;
 - disposing a second conductive layer (182);
 - patterning the second conductive layer (182)

- such that the second conductive layer (182) covers the side surfaces of the first organic functional layer (141) and the side surfaces of the first conductive layer (181);
 sequentially disposing the second organic functional layer (142) and a third conductive layer (183) over the first conductive layer (181), the second conductive layer (182), and the second electrode (102);
 patterning the second organic functional layer (142) and the third conductive layer (143) such that side surfaces of the second organic functional layer (142) and side surfaces of the third conductive layer (183) are exposed;
 disposing a fourth conductive layer (184); and
 patterning the fourth conductive layer (184) such that the fourth conductive layer (184) covers the side surfaces of the second organic functional layer (142), side surfaces of the second conductive layer (182), and the side surfaces of the third conductive layer (183).
14. A method according to claim 13, wherein the patterning the second conductive layer and the patterning the fourth conductive layer comprise a dry etching method.
15. A method of claim 13 or 14, wherein the patterning of the first organic functional layer and the first conductive layer comprises:
- disposing a first photoresist on the first conductive layer;
 removing a second portion of the first photoresist such that a first portion of the first photoresist is formed at a location corresponding to the first electrode;
 removing the first organic functional layer and the first conductive layer at a location corresponding to the second portion; and
 removing the first portion of the first photoresist.
16. A method according to claim 15, wherein removing the first organic functional layer and the first conductive layer comprises a dry etching method.
17. A method according to claim 16, wherein the dry etching method comprises:
- a first process of dry-etching the first conductive layer; and
 a second process of dry-etching the first organic functional layer.
18. A method according to one of claims 13 to 17, wherein the sequentially disposing the first organic functional layer and the first conductive layer, the disposing the second conductive layer, the sequentially disposing the second organic functional layer and the third conductive layer, and the disposing the fourth conductive layer comprise a deposition process.
19. A method according to one of claims 13 to 18, wherein, the disposing the first electrode and the second electrode comprises:
 disposing an insulating layer to cover an edge of the first electrode and an edge of the second electrode.
20. A method according to one of claims 13 to 19, further comprising: disposing a common electrode on the first conductive layer, the second conductive layer, the third conductive layer, and the fourth conductive layer, wherein the common electrode is commonly and integrally formed.
21. A method according to one of claims 13 to 20, wherein the first organic functional layer and the second organic functional layer respectively comprise a first emission layer and a second emission layer which emit light of different colors.
22. A method according to one of claims 13 to 21, wherein the OLED apparatus comprises a third pixel that includes a third electrode and a third organic functional layer, and the method further comprises:
 disposing, on the substrate, the third electrode separate from the first electrode and the second electrode;
 sequentially disposing the third organic functional layer and a fifth conductive layer on the first conductive layer, the second conductive layer, the third conductive layer, the fourth conductive layer, and the third electrode;
 patterning the third organic functional layer and the fifth conductive layer such that side surfaces of the third organic functional layer and side surfaces of the fifth conductive layer are exposed;
 disposing a sixth conductive layer; and
 patterning the sixth conductive layer such that the sixth conductive layer covers the side surfaces of the third organic functional layer, side surfaces of the fourth conductive layer, and the side surfaces of the fifth conductive layer.

Patentansprüche

1. Organische lichtemittierende Anzeigevorrichtung (OLED) (1), beinhaltend einen ersten Pixel (P1) und einen zweiten Pixel (P2), wobei der erste Pixel (P1) Folgendes beinhaltet: eine erste Elektrode (101); eine erste organische Funktionsschicht (141), welche an der ersten Elektrode (101) angeordnet ist, wobei die erste organische Funktionsschicht (141) eine erste Emissionsschicht beinhaltet; und eine erste

- gegenüberliegende Elektrode (150), welche eine Oberseite und Seitenflächen der ersten organischen Funktionsschicht (141) bedeckt; und wobei der zweite Pixel (P2) Folgendes beinhaltet: ein zweite Elektrode (102), welche separat von der ersten Elektrode (101) angeordnet ist; eine zweite organische Funktionsschicht (142), welche an der zweiten Elektrode (102) angeordnet ist, wobei die zweite organische Funktionsschicht (142) eine zweite Emissionsschicht beinhaltet; und eine zweite gegenüberliegende Elektrode (160), welche eine Oberseite und Seitenflächen der zweiten organischen Funktionsschicht (142) bedeckt; **dadurch gekennzeichnet, dass** in einer seitlichen Richtung des OLED-Gerätes (1) eine Dicke (L1) eines Abschnittes der ersten gegenüberliegenden Elektrode (150), welche an einer Seitenfläche der ersten organischen Funktionsschicht (141) angeordnet ist, größer ist als eine Dicke (L2) eines Abschnittes der zweiten gegenüberliegenden Elektrode (160), welche an einer Seitenfläche der zweiten organischen Funktionsschicht (142) angeordnet ist.
2. OLED-Gerät nach Anspruch 1, bei welchem eine erste Lichtfarbe von durch die erste Emissionsschicht emittiertem Licht sich von einer zweiten Lichtfarbe von durch die zweite Emissionsschicht emittiertem Licht unterscheidet.
 3. OLED-Gerät nach Anspruch 1 oder 2, bei welchem jede der ersten organischen Funktionsschicht und der zweiten organischen Funktionsschicht mindestens eine Schicht der Gruppe beinhaltet, bestehend aus einer Lochinjektionsschicht, einer Lochtransportschicht, einer Elektroneninjectionsschicht und einer Elektronentransportschicht.
 4. OLED-Gerät nach Anspruch 1, 2 oder 3, bei welchem eine Dicke eines Abschnittes der ersten gegenüberliegenden Elektrode, welche die Oberseite der ersten organischen Funktionsschicht bedeckt, dieselbe ist wie eine Dicke eines Abschnittes der zweiten gegenüberliegenden Elektrode, welche die Oberseite der zweiten organischen Funktionsschicht bedeckt.
 5. OLED-Gerät nach einem der vorhergehenden Ansprüche, zudem beinhaltend eine Pixel definierende Schicht, welche eine isolierende Schicht beinhaltet, wobei die Pixel definierende Schicht eine Kante der ersten Elektrode und eine Kante der zweiten Elektrode bedeckt.
 6. OLED-Gerät (1) nach Anspruch 5, bei welchem eine Kante der ersten organischen Funktionsschicht und ein Kante der zweiten organischen Funktionsschicht an einer geneigten Oberfläche der Pixel definierenden Schicht liegen.
 7. OLED-Gerät nach einem der vorhergehenden Ansprüche, zudem beinhaltend eine gemeinsame Elektrode, welche gemeinsam und einstückig an der ersten gegenüberliegenden Elektrode und der zweiten gegenüberliegenden Elektrode angeordnet ist.
 8. OLED-Gerät (1) nach Anspruch 7, bei welchem die gemeinsame Elektrode Seitenflächen der ersten gegenüberliegenden Elektrode und Seitenflächen der zweiten gegenüberliegenden Elektrode bedeckt.
 9. OLED-Gerät nach einem der vorhergehenden Ansprüche, zudem beinhaltend einen dritten Pixel, wobei der dritte Pixel Folgendes beinhaltet:
 - eine dritte Elektrode, welche separat von der ersten Elektrode und der zweiten Elektrode angeordnet ist;
 - eine dritte organische Funktionsschicht, welche an der dritten Elektrode angeordnet ist, wobei die dritte organische Funktionsschicht eine dritte Emissionsschicht beinhaltet; und
 - eine dritte gegenüberliegende Elektrode, welche eine Oberseite und Seitenflächen der dritten organischen Funktionsschicht bedeckt; wobei, in einer seitlichen Richtung des OLED-Gerätes, die Dicke des Abschnittes der zweiten gegenüberliegenden Elektrode, welche an der Seitenfläche der zweiten organischen Funktionsschicht angeordnet ist, größer ist als eine Dicke eines Abschnittes der dritten gegenüberliegenden Elektrode, welche an einer Seitenfläche der dritten organischen Funktionsschicht angeordnet ist.
 10. OLED-Gerät nach Anspruch 9, bei welchem eine erste Lichtfarbe von durch die erste Emissionsschicht emittiertem Licht, eine zweite Lichtfarbe von durch die zweite Emissionsschicht emittiertem Licht und eine dritte Lichtfarbe von durch die dritte Emissionsschicht emittiertem Licht sich voneinander unterscheiden.
 11. Organische lichtemittierende Anzeigevorrichtung (OLED), beinhaltend einen ersten Pixel (P1) und einen zweiten Pixel (P2), wobei der erste Pixel (P1) Folgendes beinhaltet: eine erste Elektrode (101); eine erste organische Funktionsschicht (141), welche an der ersten Elektrode (101) angeordnet ist, wobei die erste organische Funktionsschicht (141) eine erste Emissionsschicht beinhaltet; und eine erste gegenüberliegende Elektrode (150), welche eine Oberseite und Seitenflächen der ersten organischen Funktionsschicht (141) bedeckt; und wobei der zweite Pixel (P2) Folgendes beinhaltet: ein zweite Elektrode (102), welche separat von der ersten Elektrode (101) angeordnet ist; eine zweite organische Funktionsschicht (142), welche an der zweiten Elektrode

- (102) angeordnet ist, wobei die zweite organische Funktionsschicht (142) eine zweite Emissionsschicht beinhaltet; und eine zweite gegenüberliegende Elektrode (160), welche eine Oberseite und Seitenflächen der zweiten organischen Funktionsschicht (142) bedeckt; **dadurch gekennzeichnet, dass** ein Bereich der ersten gegenüberliegenden Elektrode (150) in Draufsicht größer als ein Bereich der zweiten gegenüberliegenden Elektrode (160) in Draufsicht ist.
- 5
- 10
12. OLED-Gerät nach Anspruch 11, bei welchem die erste gegenüberliegende Elektrode eine erste leitfähige Schicht beinhaltet, welche die Oberseite der ersten organischen Funktionsschicht bedeckt, wobei eine zweite leitfähige Schicht die Seitenflächen der ersten organischen Funktionsschicht umgreift, eine vierte leitfähige Schicht, welche Seitenflächen der zweiten leitfähigen Schicht umgreift, und eine sechste leitfähige Schicht, welche Seitenflächen der vierten leitfähigen Schicht umgreift, und wobei die zweite gegenüberliegende Elektrode eine dritte leitfähige Schicht beinhaltet, welche die Oberseite der zweiten organischen Funktionsschicht bedeckt, wobei die vierte leitfähige Schicht die Seitenflächen der zweiten organischen Funktionsschicht umgreift, und wobei die sechste leitfähige Schicht die Seitenflächen der vierten leitfähigen Schicht umgreift.
- 15
- 20
- 25
- 30
- 35
- 40
- 45
- 50
- 55
13. Verfahren zum Herstellen eines organischen lichtemittierenden Anzeigeegerätes (OLED) nach Anspruch 1, welches einen ersten Pixel (P1) beinhaltet, welcher eine erste Elektrode (101) und eine erste organische Funktionsschicht (141) umfasst, und welches einen zweiten Pixel (P2) beinhaltet, welcher eine zweite Elektrode (102) und eine zweite organische Funktionsschicht (142) umfasst, wobei das Verfahren Folgendes beinhaltet:
- Anordnen der ersten Elektrode (101) und der zweiten Elektrode (102) separat voneinander an einem Substrat; sequenzielles Anordnen der ersten organischen Funktionsschicht (141) und einer ersten leitfähigen Schicht (181) über der ersten Elektrode (101); Mustern der ersten organischen Funktionsschicht (141) und der ersten leitfähigen Schicht (181) in einer Weise, dass Seitenflächen der ersten organischen Funktionsschicht und Seitenflächen der ersten leitfähigen Schicht (181) exponiert sind; Anordnen einer zweiten leitfähigen Schicht (182); Mustern der zweiten leitfähigen Schicht (182) in einer Weise, dass die zweite leitfähige Schicht (182) die Seitenflächen der ersten organischen Funktionsschicht (141) und die Seitenflächen der ersten organischen Funktionsschicht (181) bedeckt; sequenzielles Anordnen
- der zweiten organischen Funktionsschicht (142) und einer dritten leitfähigen Schicht (183) über der ersten leitfähigen Schicht (181), der zweiten leitfähigen Schicht (182) und der zweiten Elektrode (102); Mustern der zweiten organischen Funktionsschicht (142) und der dritten leitfähigen Schicht (143) in einer Weise, dass Seitenflächen der zweiten organischen Funktionsschicht (142) und Seitenflächen der dritten leitfähigen Schicht (183) exponiert sind; Anordnen einer vierten leitfähigen Schicht (184); und Mustern der vierten leitfähigen Schicht (184) in einer Weise, dass die vierte leitfähige Schicht (184) die Seitenflächen der zweiten organischen Funktionsschicht (142), Seitenflächen der zweiten leitfähigen Schicht (182) und die Seitenflächen der dritten leitfähigen Schicht (183) bedeckt.
14. Verfahren nach Anspruch 13, bei welchem das Mustern der zweiten leitfähigen Schicht und das Mustern der vierten leitfähigen Schicht ein Trockenätzverfahren beinhaltet.
15. Verfahren nach Anspruch 13 oder 14, bei welchem das Mustern der ersten organischen Funktionsschicht und der ersten leitfähigen Schicht Folgendes beinhaltet:
- Anordnen eines ersten Fotoresists an der ersten leitfähigen Schicht; Entfernen eines zweiten Abschnitts des ersten Fotoresists in einer Weise, dass ein erster Abschnitt des ersten Fotoresists an einer Position gebildet wird, welche der ersten Elektrode entspricht; Entfernen der ersten organischen Funktionsschicht und der ersten leitfähigen Schicht an einer Position, welche dem zweiten Abschnitt entspricht; und Entfernen des ersten Abschnitts des ersten Fotoresists.
16. Verfahren nach Anspruch 15, bei welchem Entfernen der ersten Funktionsschicht und der ersten leitfähigen Schicht ein Trockenätzverfahren beinhaltet.
17. Verfahren nach Anspruch 16, bei welchem das Trockenätzverfahren Folgendes beinhaltet:
- einen ersten Prozess des Trockenätzens der ersten leitfähigen Schicht; und einen zweiten Prozess des Trockenätzens der ersten organischen Funktionsschicht.
18. Verfahren nach einem der Ansprüche 13 bis 17, bei welchem das sequenzielle Anordnen der ersten organischen Funktionsschicht und der ersten leitfähigen

gen Schicht, das Anordnen der zweiten leitfähigen Schicht, das sequenzielle Anordnen der zweiten organischen Funktionsschicht und der dritten leitfähigen Schicht und das Anordnen der vierten leitfähigen Schicht einen Ablagerungsprozess beinhalten.

19. Verfahren nach einem der Ansprüche 13 bis 18, bei welchem Anordnen der ersten Elektrode und der zweiten Elektrode Folgendes beinhaltet:
Anordnen einer isolierenden Schicht zum Bedecken einer Kante der ersten Elektrode und einer Kante der zweiten Elektrode.

20. Verfahren nach einem der Ansprüche 13 bis 19, zu dem Folgendes beinhaltend: Anordnen einer gemeinsamen Elektrode an der ersten leitfähigen Schicht, der zweiten leitfähigen Schicht, der dritten leitfähigen Schicht und der vierten leitfähigen Schicht, wobei die gemeinsame Elektrode gemeinsam und einstückig gebildet ist.

21. Verfahren nach einem der Ansprüche 13 bis 20, bei welchem die erste organische Funktionsschicht und die zweite organische Funktionsschicht jeweils eine erste Emissionsschicht und eine zweite Emissionsschicht beinhalten, welche Licht unterschiedlicher Farben emittieren.

22. Verfahren nach einem der Ansprüche 13 bis 21, bei welchem das OLED-Gerät einen dritten Pixel beinhaltet, welcher eine dritte Elektrode und eine dritte organische Funktionsschicht umfasst, und wobei das Verfahren zudem Folgendes beinhaltet:

Anordnen der dritten Elektrode separat von der ersten Elektrode und der zweiten Elektrode an dem Substrat;

sequenzielles Anordnen der dritten organischen Funktionsschicht und einer fünften leitfähigen Schicht an der ersten leitfähigen Schicht, der zweiten leitfähigen Schicht, der dritten leitfähigen Schicht, der vierten leitfähigen Schicht und der dritten Elektrode;

Mustern der dritten organischen Funktionsschicht und der fünften leitfähigen Schicht in einer Weise, dass Seitenflächen der dritten organischen Funktionsschicht und Seitenflächen der fünften leitfähigen Schicht exponiert sind;

Anordnen einer sechsten leitfähigen Schicht; und

Mustern der sechsten leitfähigen Schicht in einer Weise, dass die sechste leitfähige Schicht die Seitenflächen der dritten organischen Funktionsschicht, Seitenflächen der vierten leitfähigen Schicht und die Seitenflächen der fünften leitfähigen Schicht bedeckt.

Revendications

1. Appareil d'affichage électroluminescent organique (OLED) (1) comprenant un premier pixel (P1) et un deuxième pixel (P2), dans lequel le premier pixel (P1) comprend : une première électrode (101) ; une première couche fonctionnelle organique (141) disposée sur la première électrode (101), la première couche fonctionnelle organique (141) comprenant une première couche d'émission ; et une première électrode opposée (150) recouvrant une surface supérieure et les surfaces latérales de la première couche fonctionnelle organique (141) ; et dans lequel le deuxième pixel (P2) comprend :

une deuxième électrode (102) disposée séparément de la première électrode (101) ; une deuxième couche fonctionnelle organique (142) disposée sur la deuxième électrode (102), la deuxième couche fonctionnelle organique (142) comprenant une deuxième couche d'émission ; et une deuxième électrode opposée (160) recouvrant une surface supérieure et les surfaces latérales de la deuxième couche fonctionnelle organique (142) ; **caractérisé en ce que**, dans une direction latérale de l'appareil OLED (1), une épaisseur (L1) d'une partie de la première électrode opposée (150) disposée sur une surface latérale de la première couche fonctionnelle organique (141) est plus grande qu'une épaisseur (L2) d'une partie de la deuxième électrode opposée (160) disposée sur une surface latérale de la deuxième couche fonctionnelle organique (142).

2. Appareil OLED selon la revendication 1, dans lequel une première couleur de la lumière émise à partir de la première couche d'émission est différente d'une deuxième couleur de la lumière émise à partir de la deuxième couche d'émission.

3. Appareil OLED selon la revendication 1 ou 2, dans lequel chacune de la première couche fonctionnelle organique et de la deuxième couche fonctionnelle organique comprend au moins une couche sélectionnée dans le groupe consistant en une couche d'injection de trous, une couche de transport de trous, une couche d'injection d'électrons, et une couche de transport d'électrons.

4. Appareil OLED selon la revendication 1, 2 ou 3, dans lequel une épaisseur d'une partie de la première électrode opposée recouvrant la surface supérieure de la première couche fonctionnelle organique est identique à une épaisseur d'une partie de la deuxième électrode opposée recouvrant la surface supérieure de la deuxième couche fonctionnelle organique.

5. Appareil OLED selon l'une quelconque des revendications précédentes, comprenant en outre une couche de définition de pixel comprenant une couche isolante, la couche de définition de pixel recouvrant un bord de la première électrode et un bord de la deuxième électrode. 5
6. Appareil OLED selon la revendication 5, dans lequel un bord de la première couche fonctionnelle organique et un bord de la deuxième couche fonctionnelle organique sont disposés sur une surface inclinée de la couche de définition de pixel. 10
7. Appareil OLED selon l'une quelconque des revendications précédentes, comprenant en outre une électrode commune qui est disposée communément et intégralement sur la première électrode opposée et la deuxième électrode opposée. 15
8. Appareil OLED selon la revendication 7, dans lequel l'électrode commune recouvre les surfaces latérales de la première électrode opposée et les surfaces latérales de la deuxième électrode opposée. 20
9. Appareil OLED selon l'une quelconque des revendications précédentes, comprenant en outre un troisième pixel, dans lequel le troisième pixel comprend : 25
- une troisième électrode disposée séparément de la première électrode et de la deuxième électrode ; 30
 - une troisième couche fonctionnelle organique disposée sur la troisième électrode, la troisième couche fonctionnelle organique comprenant une troisième couche d'émission ; et 35
 - une troisième électrode opposée recouvrant une surface supérieure et les surfaces latérales de la troisième couche fonctionnelle organique ; dans lequel, dans une direction latérale de l'appareil OLED, ladite épaisseur de la partie de la deuxième électrode opposée qui est disposée sur la surface latérale de la deuxième couche fonctionnelle organique est plus grande qu'une épaisseur d'une partie de la troisième électrode opposée disposée sur une surface latérale de la troisième couche fonctionnelle organique. 40 45
10. Appareil OLED selon la revendication 9, dans lequel une première couleur de la lumière émise à partir de la première couche d'émission, une deuxième couleur de la lumière émise à partir de la deuxième couche d'émission, et une troisième couleur de la lumière émise à partir de la troisième couche d'émission sont différentes les unes des autres. 50 55
11. Appareil d'affichage électroluminescent organique (OLED) comprenant un premier pixel (P1) et un deuxième pixel (P2), dans lequel le premier pixel (P1) comprend : une première électrode (101) ; une première couche fonctionnelle organique (141) disposée sur la première électrode (101), la première couche fonctionnelle organique (141) comprenant une première couche d'émission ; et une première électrode opposée (150) recouvrant une surface supérieure et les surfaces latérales de la première couche fonctionnelle organique (141) ; et dans lequel le deuxième pixel (P2) comprend :
- une deuxième électrode (102) disposée séparément de la première électrode (101) ; une deuxième couche fonctionnelle organique (142) disposée sur la deuxième électrode (102), la deuxième couche fonctionnelle organique (142) comprenant une deuxième couche d'émission ; et une deuxième électrode opposée (160) recouvrant une surface supérieure et les surfaces latérales de la deuxième couche fonctionnelle organique (142); **caractérisé en ce qu'une aire de la première électrode opposée (150) en vue plane est plus grande qu'une aire de la deuxième électrode opposée (160) en vue plane.**
12. Appareil OLED selon la revendication 11, dans lequel la première électrode opposée comprend une première couche conductrice recouvrant la surface supérieure de la première couche fonctionnelle organique, une deuxième couche conductrice entourant les surfaces latérales de la première couche fonctionnelle organique, une quatrième couche conductrice entourant les surfaces latérales de la deuxième couche conductrice, et une sixième couche conductrice entourant les surfaces latérales de la quatrième couche conductrice, et dans lequel la deuxième électrode opposée comprend une troisième couche conductrice recouvrant la surface supérieure de la deuxième couche fonctionnelle organique, la quatrième couche conductrice entourant les surfaces latérales de la deuxième couche fonctionnelle organique, et la sixième couche conductrice entourant les surfaces latérales de la quatrième couche conductrice.
13. Procédé de fabrication d'un appareil d'affichage électroluminescent organique (OLED) selon la revendication 1 qui comprend un premier pixel (P1) qui comprend une première électrode (101) et une première couche fonctionnelle organique (141), et qui comprend un deuxième pixel (P2) qui comprend une deuxième électrode (102) et une deuxième couche fonctionnelle organique (142), le procédé comprenant : la disposition de la première électrode (101) et de la deuxième électrode (102) séparément l'une de l'autre sur un substrat ; la disposition séquentielle de la première couche fonctionnelle orga-

- nique (141) et d'une première couche conductrice (181) sur la première électrode (101) ; la structuration de la première couche fonctionnelle organique (141) et de la première couche conductrice (181) de sorte que les surfaces latérales de la première couche fonctionnelle organique et les surfaces latérales de la première couche conductrice (181) soient exposées ; la disposition d'une deuxième couche conductrice (182) ; la structuration de la deuxième couche conductrice (182) de sorte que la deuxième couche conductrice (182) recouvre les surfaces latérales de la première couche fonctionnelle organique (141) et les surfaces latérales de la première couche conductrice (181) ; la disposition séquentielle de la deuxième couche fonctionnelle organique (142) et d'une troisième couche conductrice (183) sur la première couche conductrice (181), la deuxième couche conductrice (182), et la deuxième électrode (102) ; la structuration de la deuxième couche fonctionnelle organique (142) et de la troisième couche conductrice (143) de sorte que les surfaces latérales de la deuxième couche fonctionnelle organique (142) et les surfaces latérales de la troisième couche conductrice (183) soient exposées ; la disposition d'une quatrième couche conductrice (184) ; et la structuration de la quatrième couche conductrice (184) de sorte que la quatrième couche conductrice (184) recouvre les surfaces latérales de la deuxième couche fonctionnelle organique (142), les surfaces latérales de la deuxième couche conductrice (182), et les surfaces latérales de la troisième couche conductrice (183).
- 14.** Procédé selon la revendication 13, dans lequel la structuration de la deuxième couche conductrice et la structuration de la quatrième couche conductrice comprennent un procédé de gravure à sec.
- 15.** Procédé selon la revendication 13 ou 14, dans lequel la structuration de la première couche fonctionnelle organique et de la première couche conductrice comprend :
- la disposition d'une première résine photosensible sur la première couche conductrice ;
 - le retrait d'une deuxième partie de la première résine photosensible de sorte qu'une première partie de la première résine photosensible soit formée à un emplacement correspondant à la première électrode ;
 - le retrait de la première couche fonctionnelle organique et de la première couche conductrice à un emplacement correspondant à la deuxième partie ; et
 - le retrait de la première partie de la première résine photosensible.
- 16.** Procédé selon la revendication 15, dans lequel le
- retrait de la première couche fonctionnelle organique et de la première couche conductrice comprend un procédé de gravure à sec.
- 17.** Procédé selon la revendication 16, dans lequel le procédé de gravure à sec comprend :
- un premier processus de gravure à sec de la première couche conductrice ; et
 - un deuxième processus de gravure à sec de la première couche fonctionnelle organique.
- 18.** Procédé selon l'une des revendications 13 à 17, dans lequel la disposition séquentielle de la première couche fonctionnelle organique et de la première couche conductrice, la disposition de la deuxième couche conductrice, la disposition séquentielle de la deuxième couche fonctionnelle organique et de la troisième couche conductrice, et la disposition de la quatrième couche conductrice comprennent un processus de dépôt.
- 19.** Procédé selon l'une des revendications 13 à 18, dans lequel la disposition de la première électrode et de la deuxième électrode comprend :
- la disposition d'une couche isolante de manière à recouvrir un bord de la première électrode et un bord de la deuxième électrode.
- 20.** Procédé selon l'une des revendications 13 à 19, comprenant en outre : la disposition d'une électrode commune sur la première couche conductrice, la deuxième couche conductrice, la troisième couche conductrice, et la quatrième couche conductrice, dans lequel l'électrode commune est formée communément et intégralement.
- 21.** Procédé selon l'une des revendications 13 à 20, dans lequel la première couche fonctionnelle organique et la deuxième couche fonctionnelle organique comprennent respectivement une première couche d'émission et une deuxième couche d'émission qui émettent des lumières de différentes couleurs.
- 22.** Procédé selon l'une des revendications 13 à 21, dans lequel l'appareil OLED comprend un troisième pixel qui comprend une troisième électrode et une troisième couche fonctionnelle organique, et le procédé comprend en outre :
- la disposition, sur le substrat, de la troisième électrode séparément de la première électrode et de la deuxième électrode ;
 - la disposition séquentielle de la troisième couche fonctionnelle organique et d'une cinquième couche conductrice sur la première couche conductrice, la deuxième couche conductrice, la troisième couche conductrice, la quatrième cou-

che conductrice, et la troisième électrode ;
la structuration de la troisième couche fonctionnelle organique et de la cinquième couche conductrice de sorte que les surfaces latérales de la troisième couche fonctionnelle organique et les surfaces latérales de la cinquième couche conductrice soient exposées ;
la disposition d'une sixième couche conductrice ; et
la structuration de la sixième couche conductrice de sorte que la sixième couche conductrice recouvre les surfaces latérales de la troisième couche fonctionnelle organique, les surfaces latérales de la quatrième couche conductrice, et les surfaces latérales de la cinquième couche conductrice.

5

10

15

20

25

30

35

40

45

50

55

FIG. 1

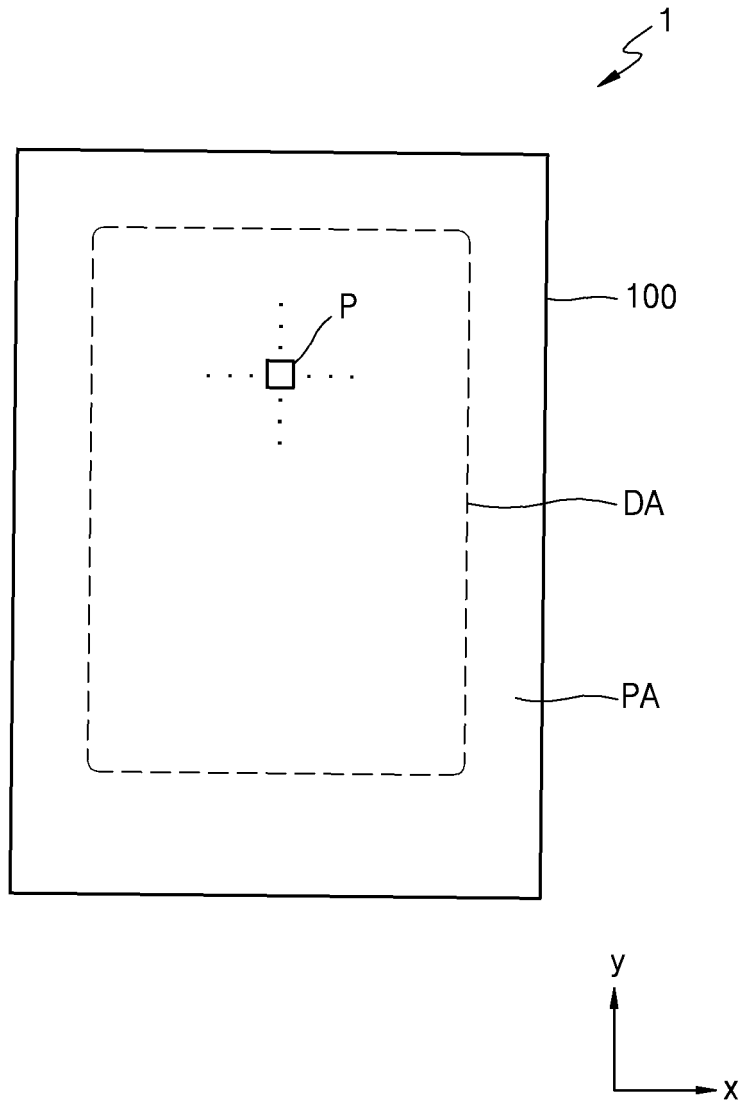

FIG. 2

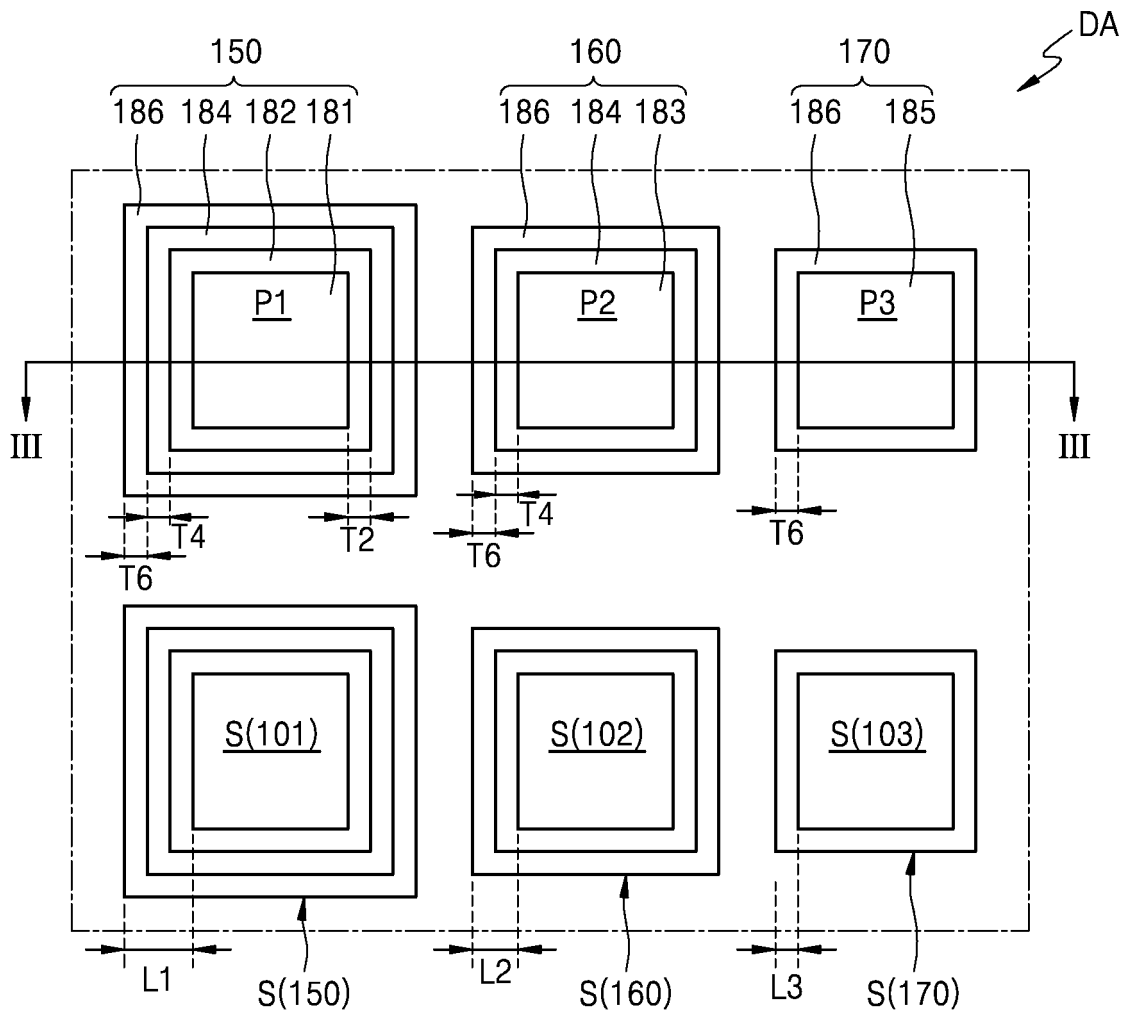

FIG. 3

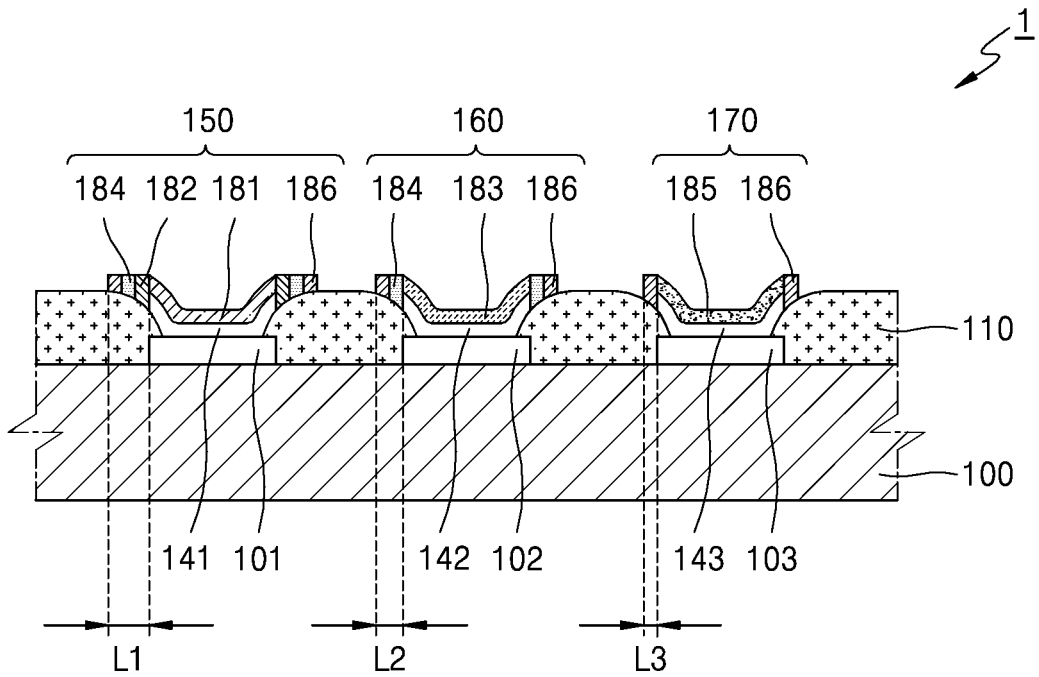

FIG. 4

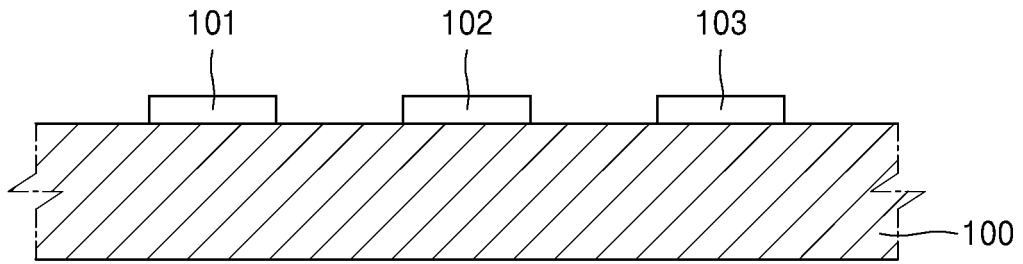

FIG. 5

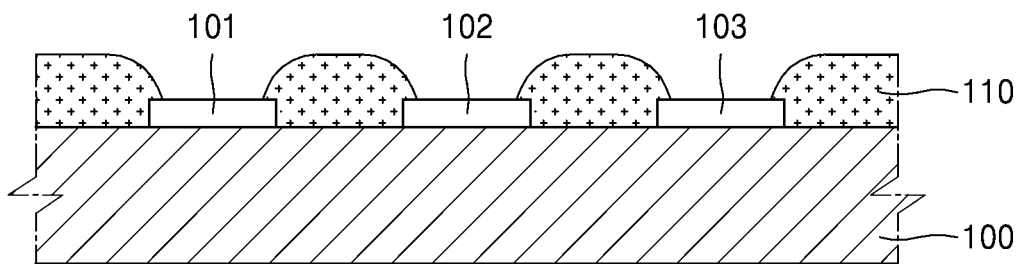

FIG. 6A

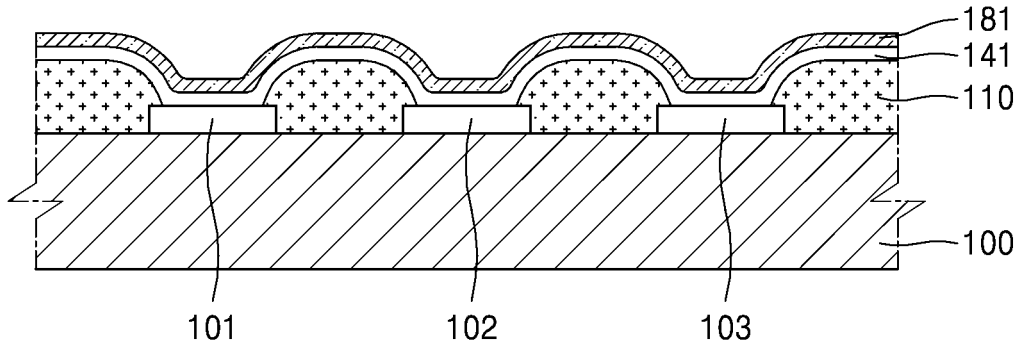

FIG. 6B

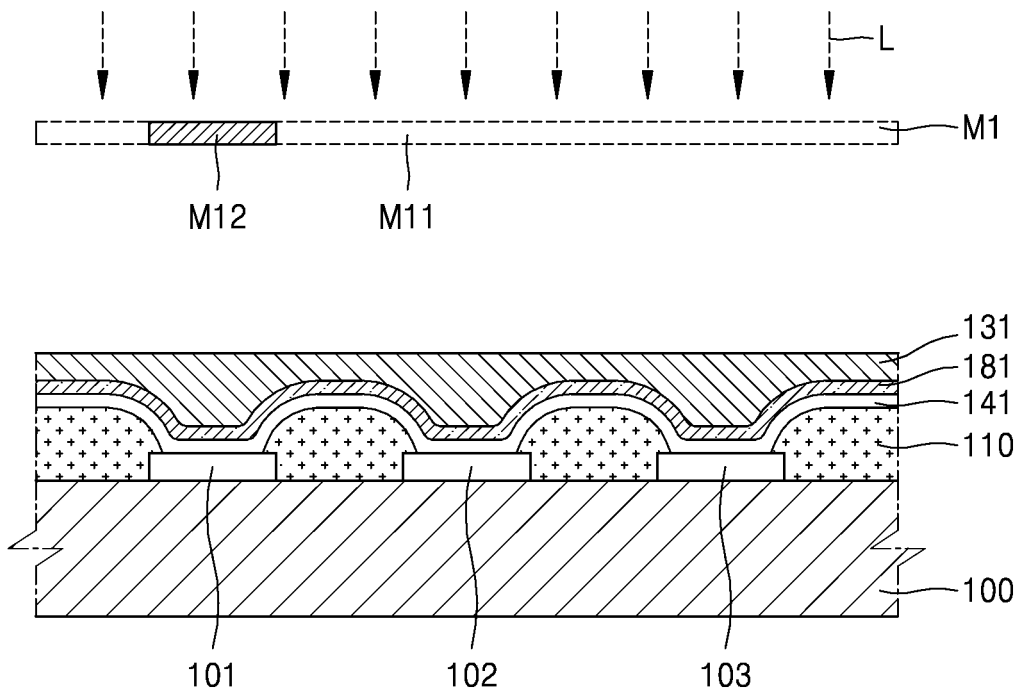

FIG. 6C

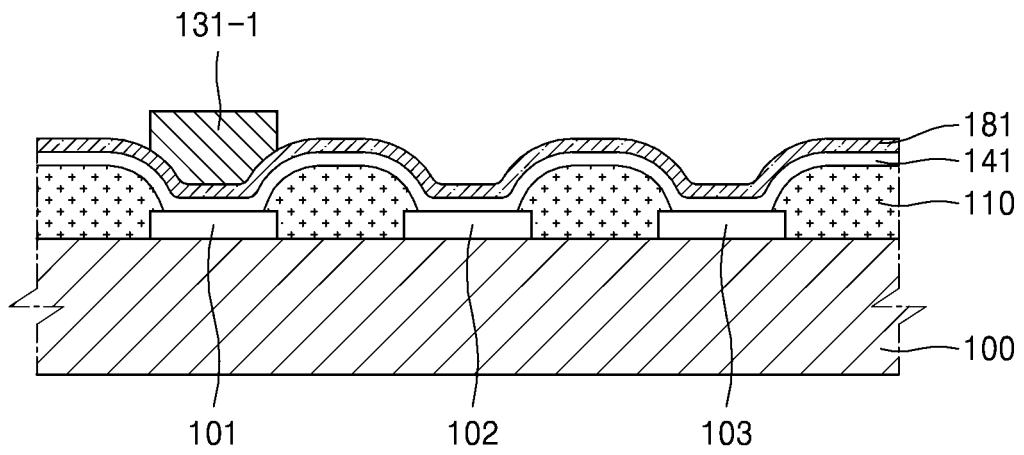

FIG. 6D

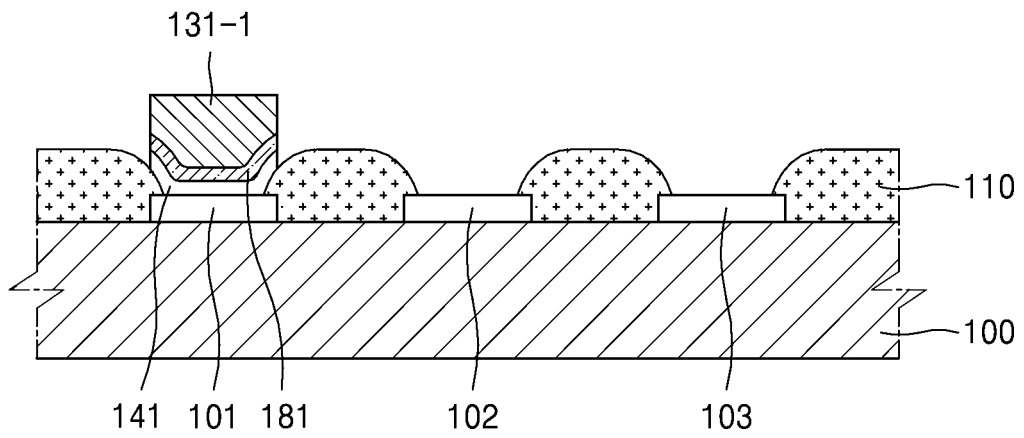

FIG. 6E

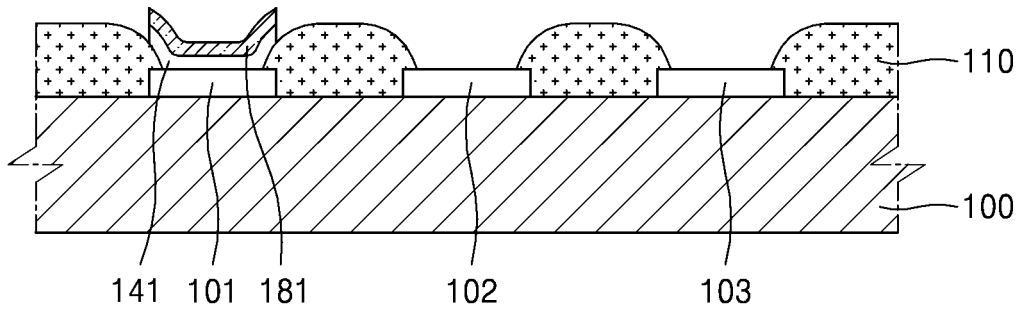

FIG. 6F

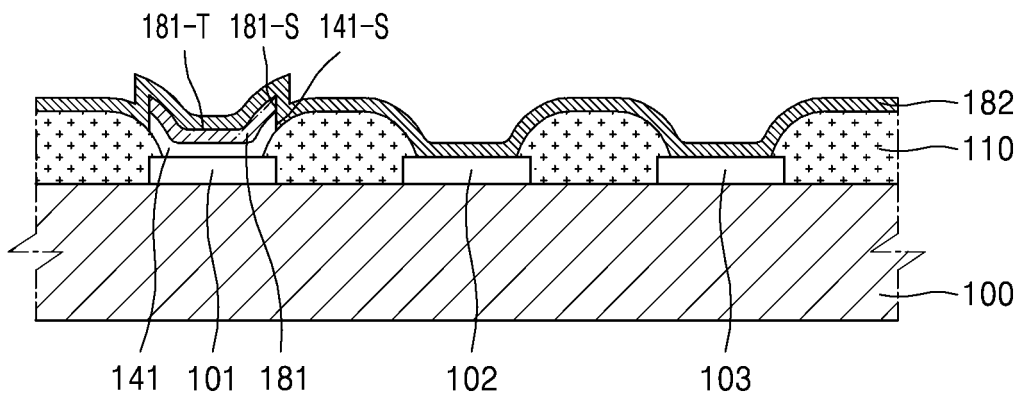

FIG. 6G

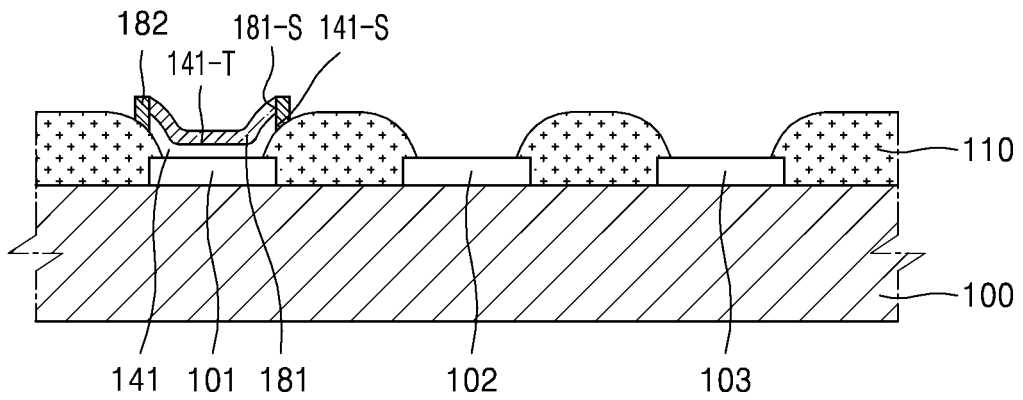

FIG. 7A

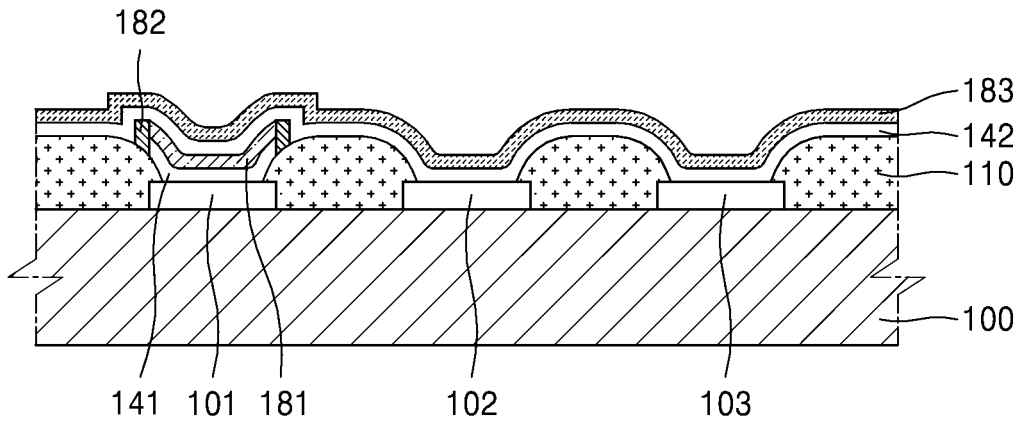

FIG. 7B

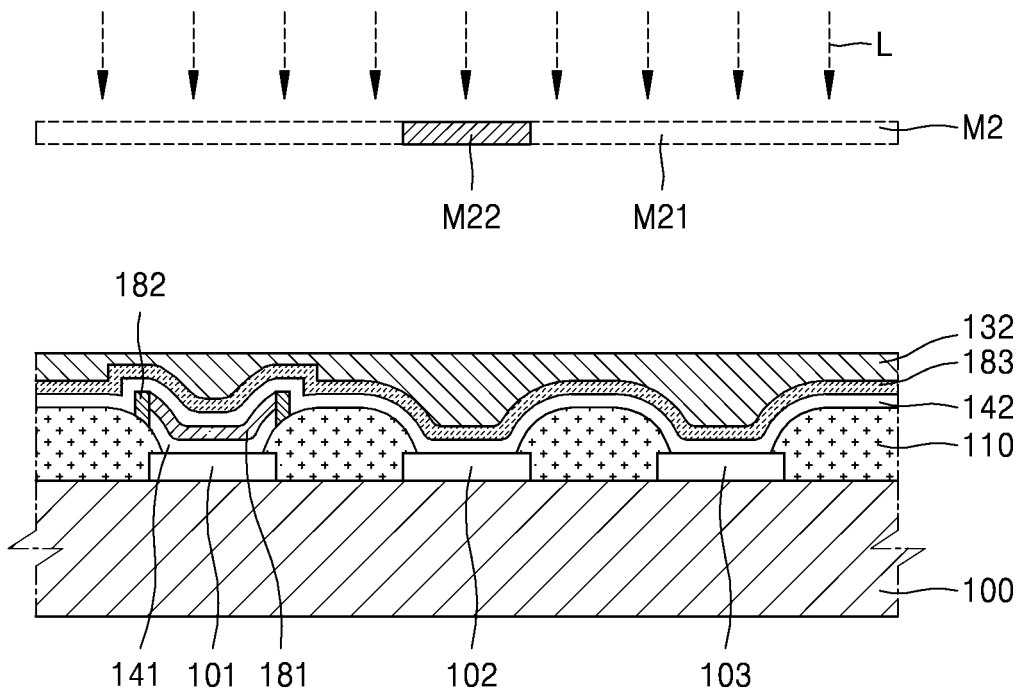

FIG. 7C

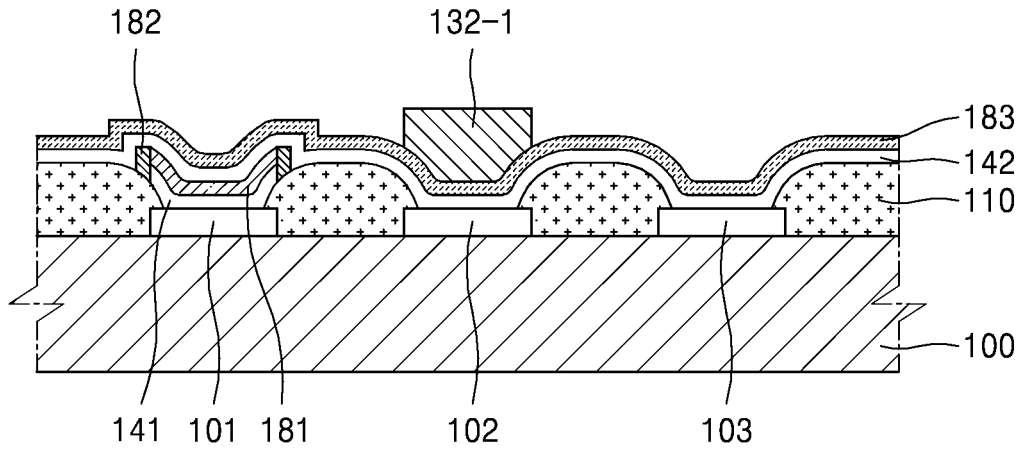

FIG. 7D

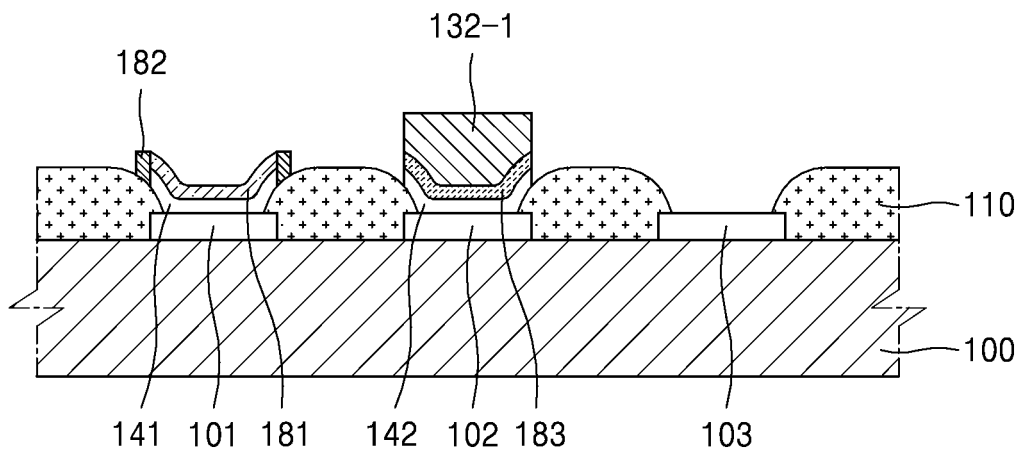

FIG. 7E

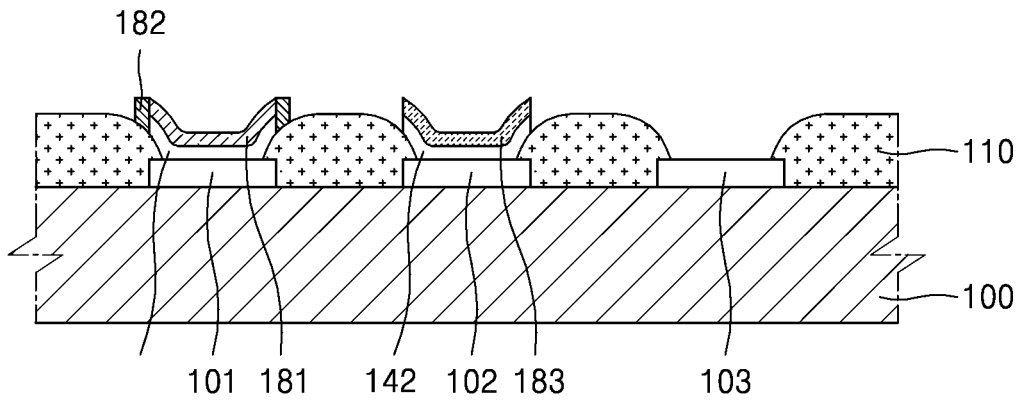

FIG. 7F

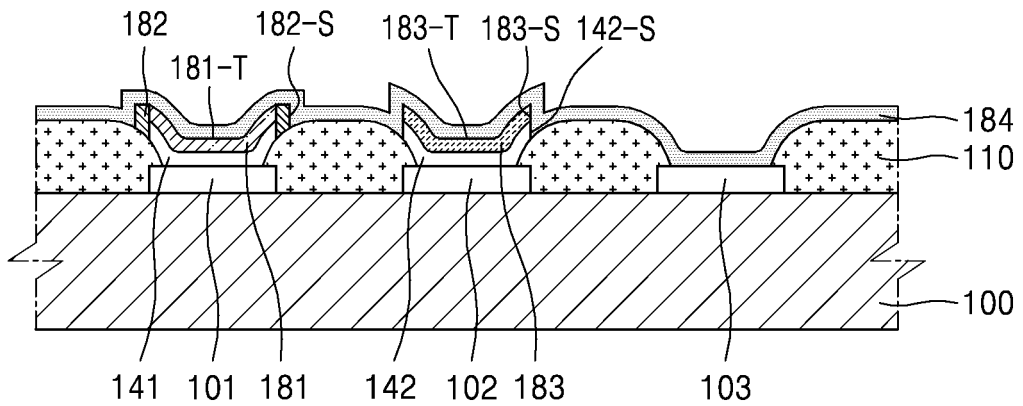

FIG. 7G

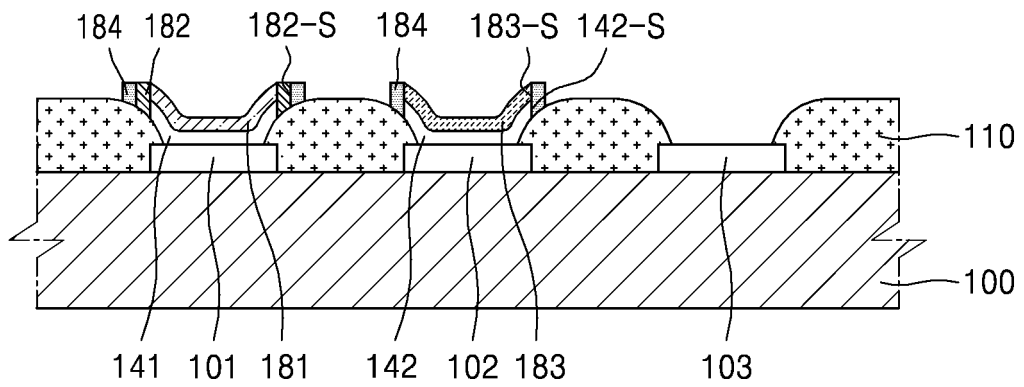

FIG. 8A

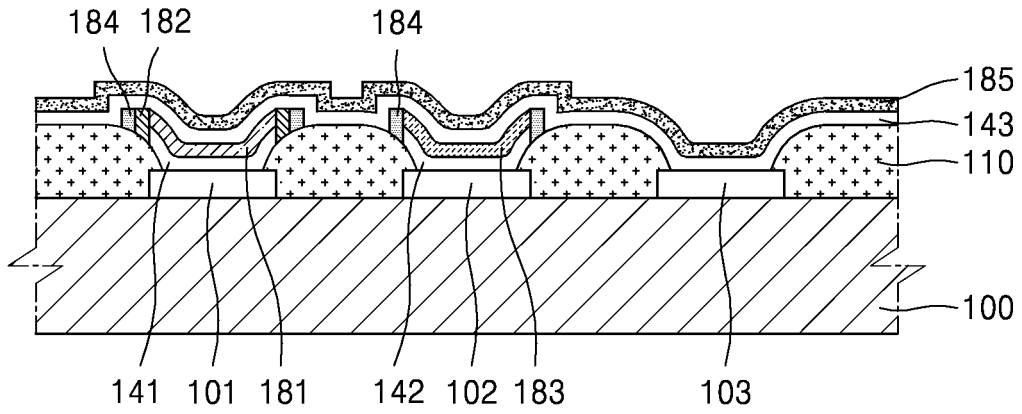

FIG. 8B

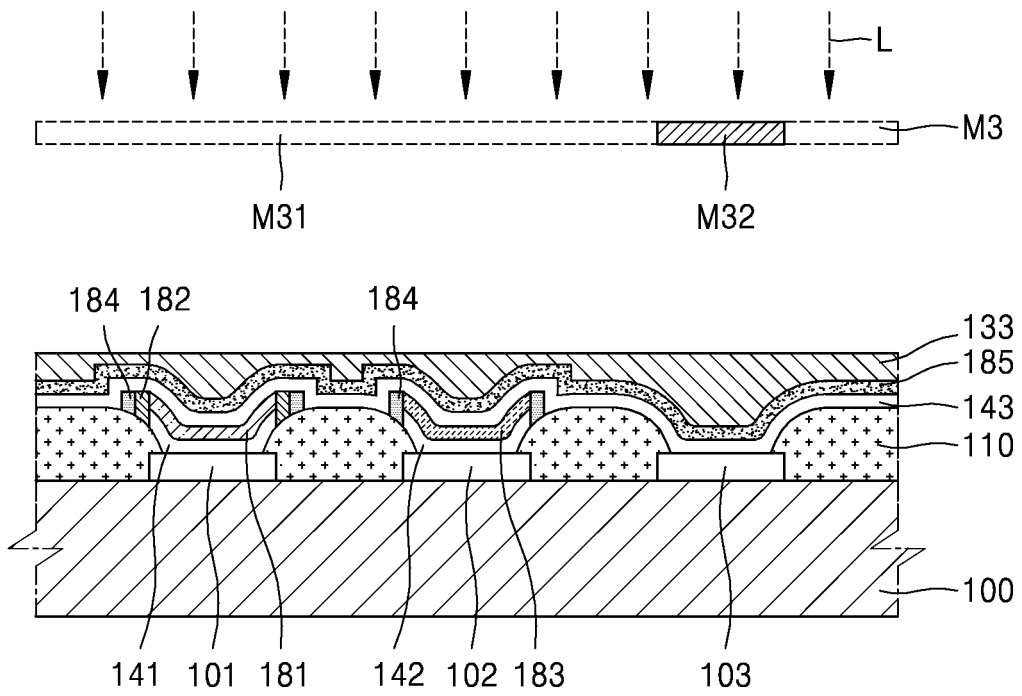

FIG. 8C

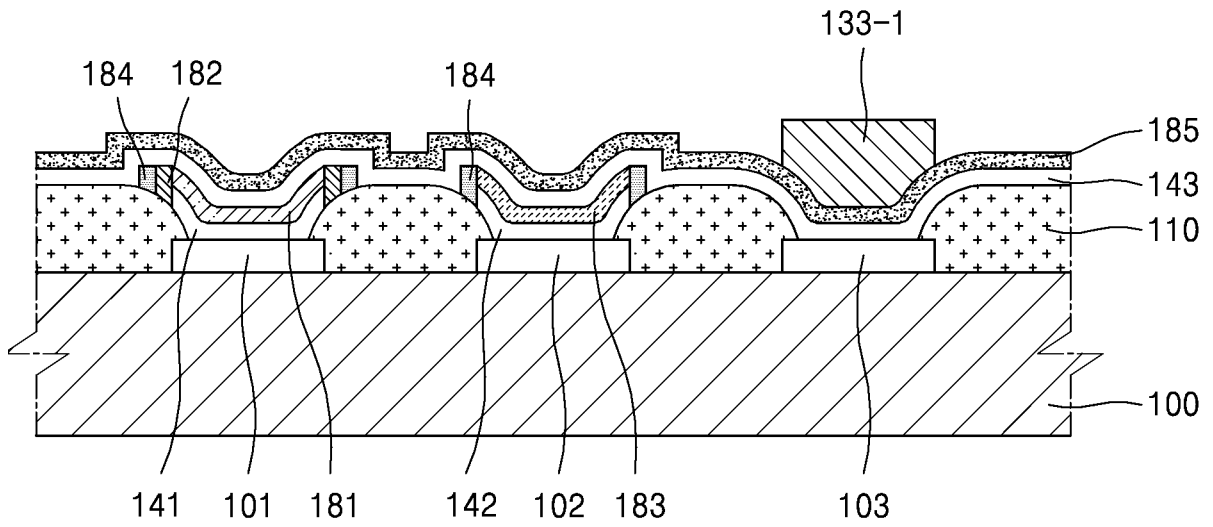

FIG. 8D

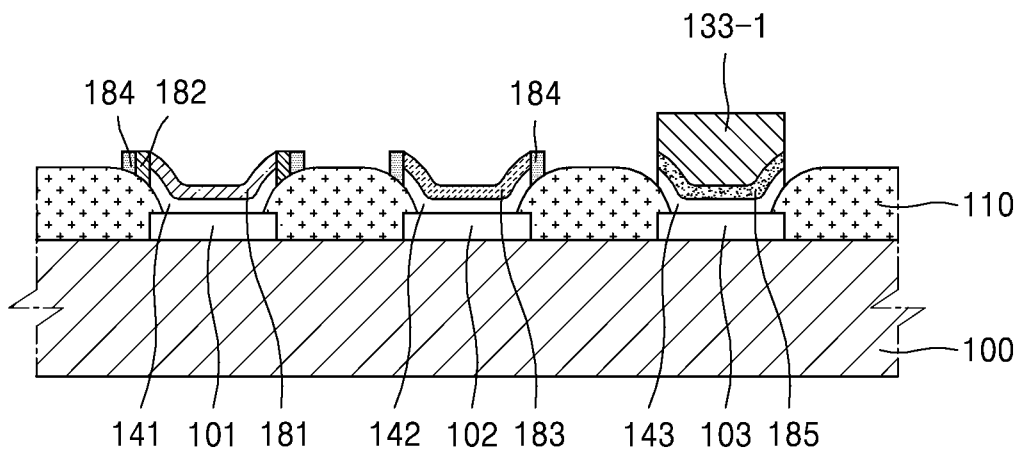

FIG. 8E

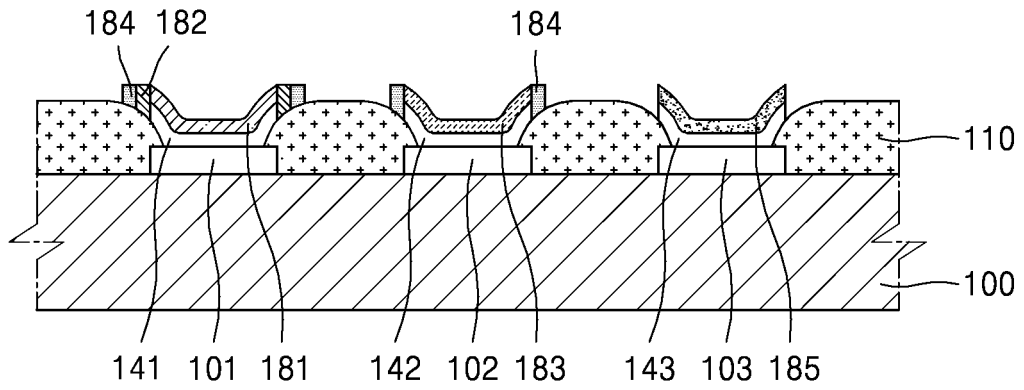

FIG. 8F

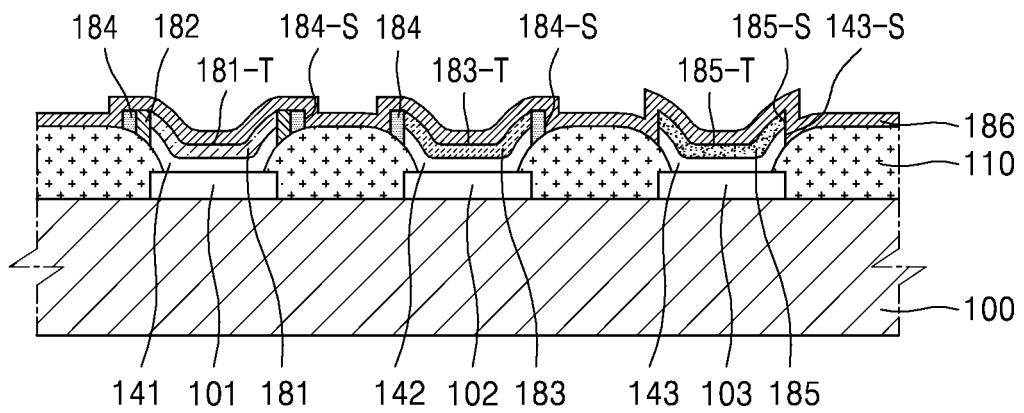

FIG. 8G

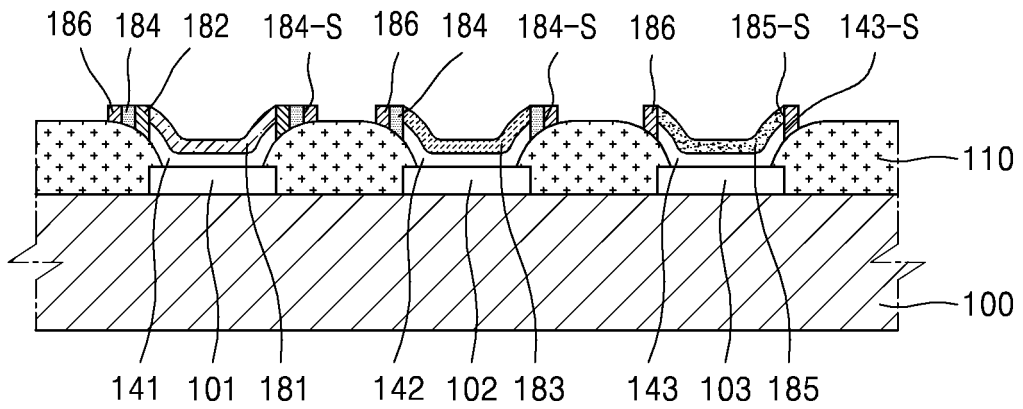

FIG. 9A

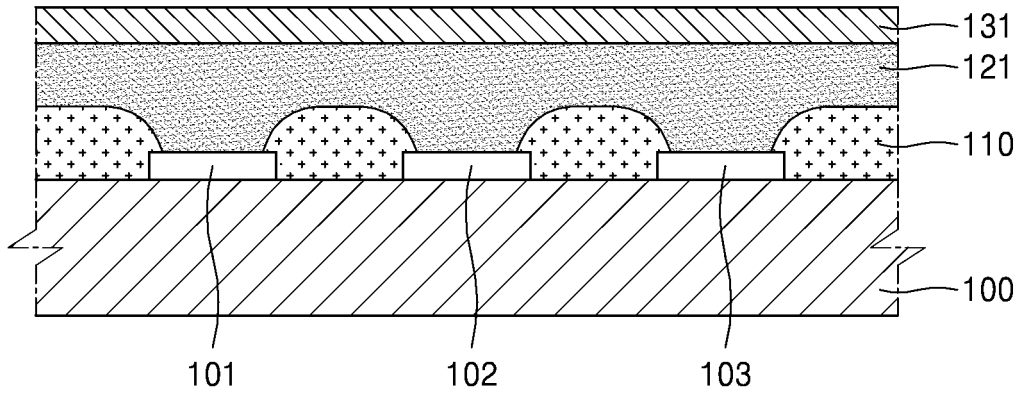

FIG. 9B

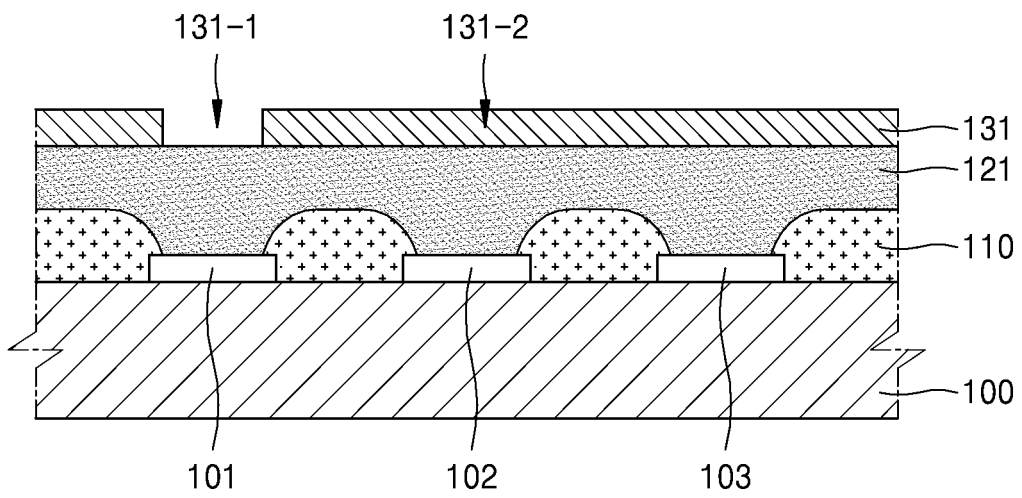

FIG. 9C

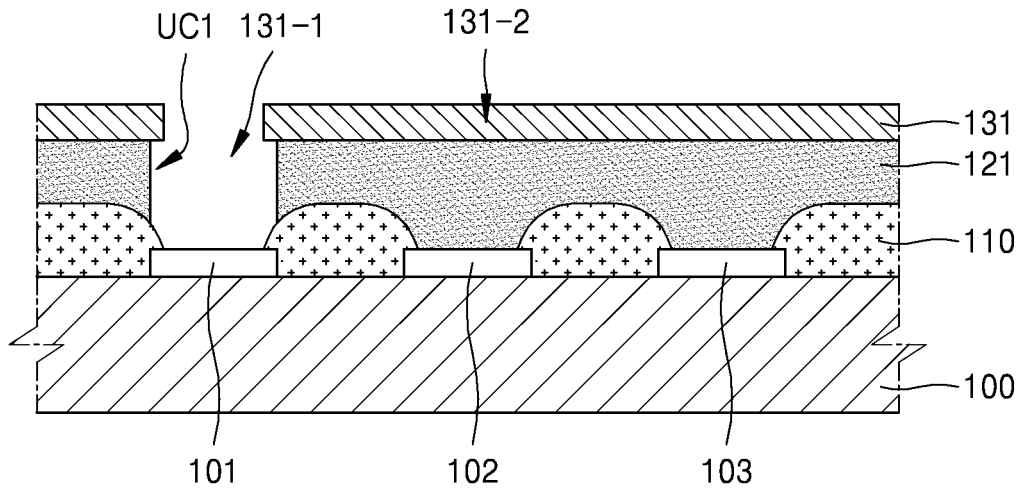

FIG. 9D

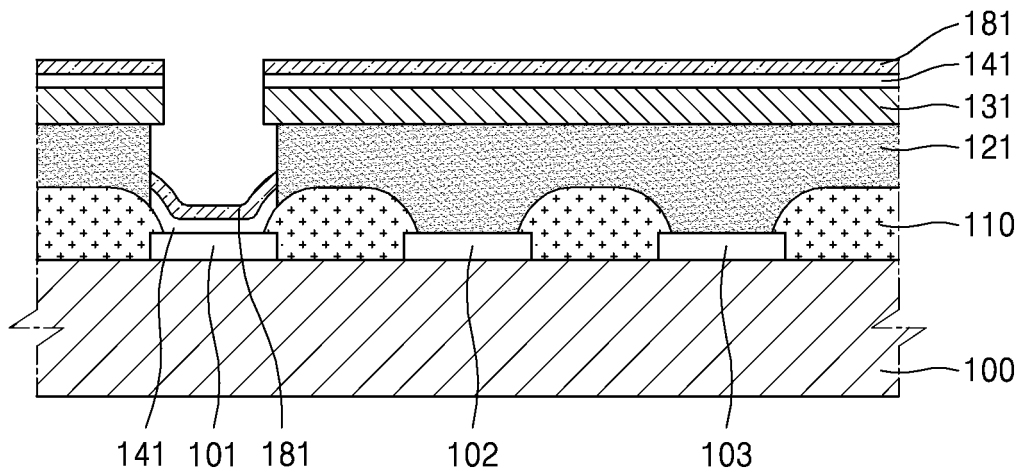

FIG. 9E

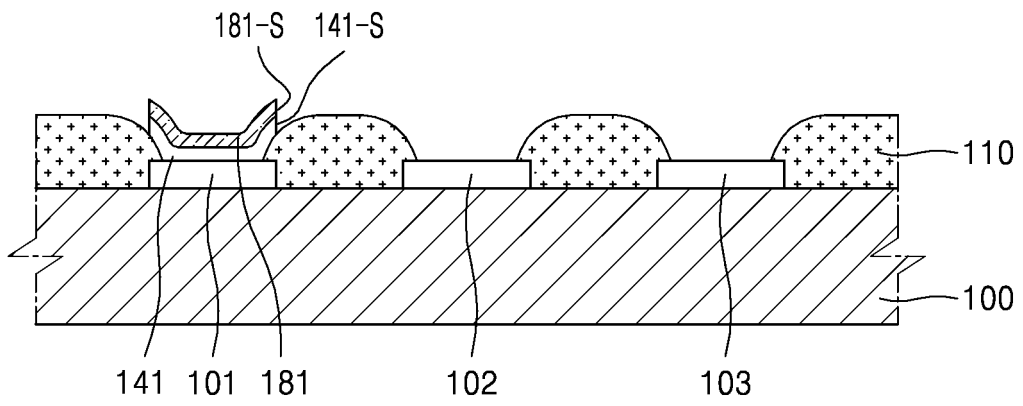

FIG. 10A

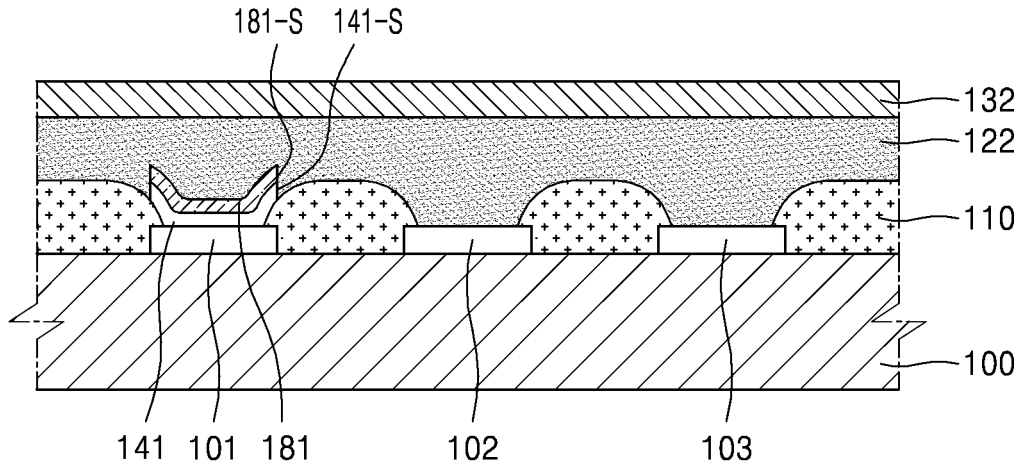

FIG. 10B

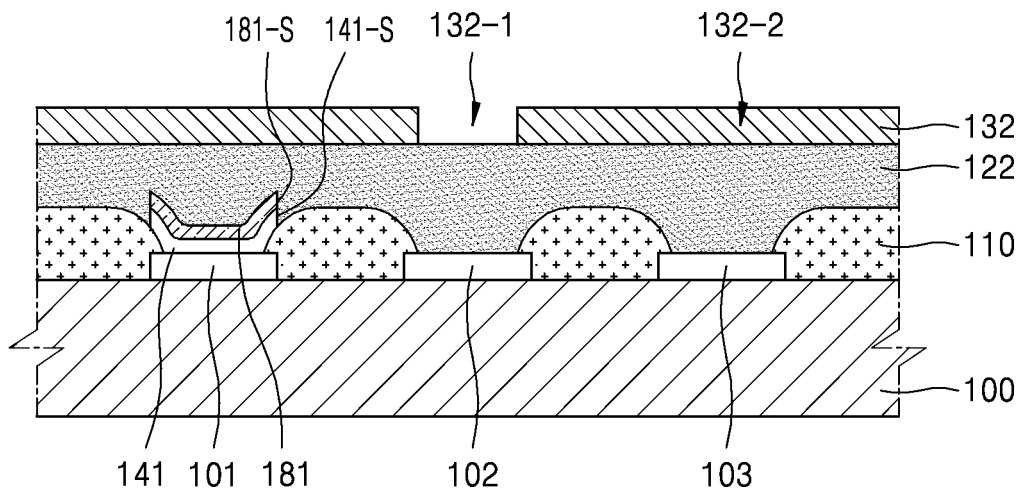

FIG. 10C

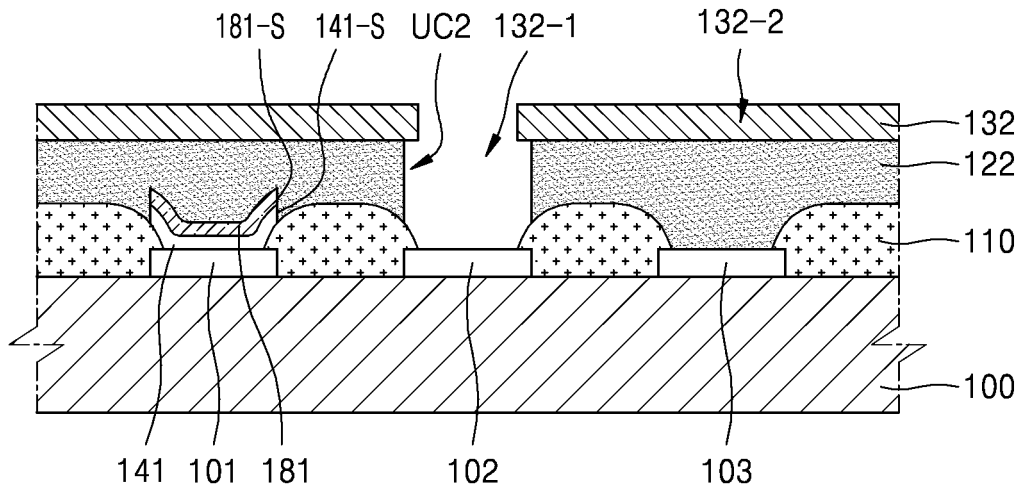

FIG. 10D

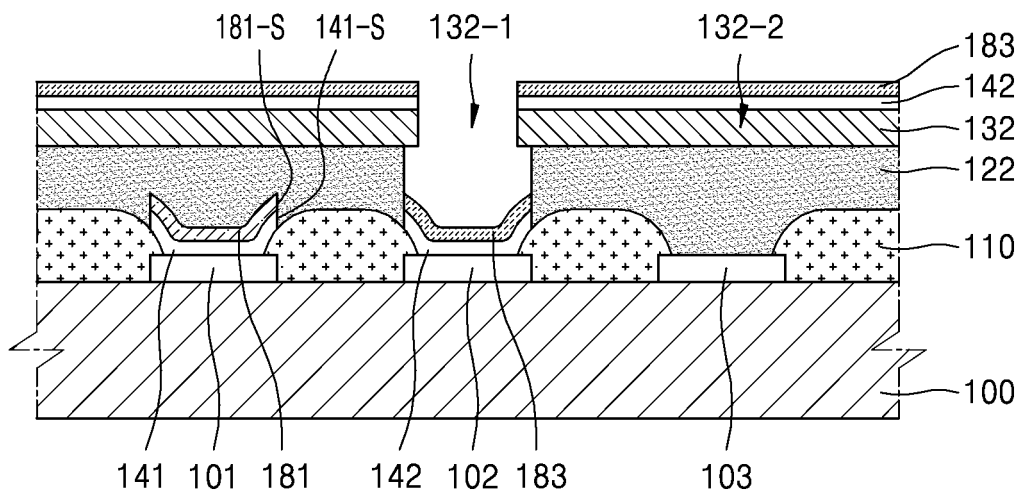

FIG. 10E

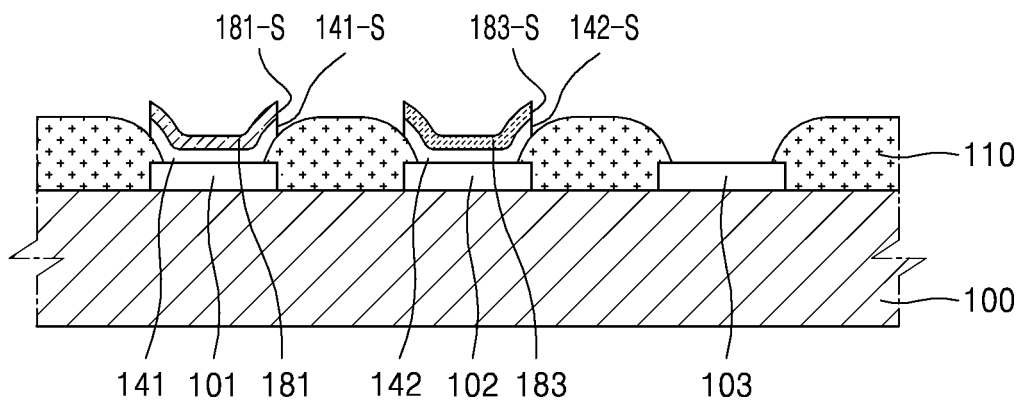

FIG. 11A

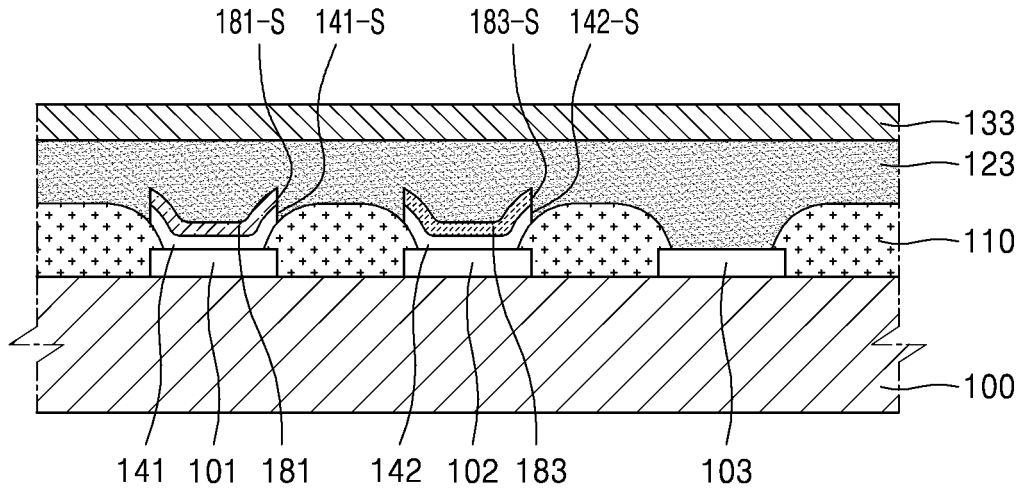

FIG. 11B

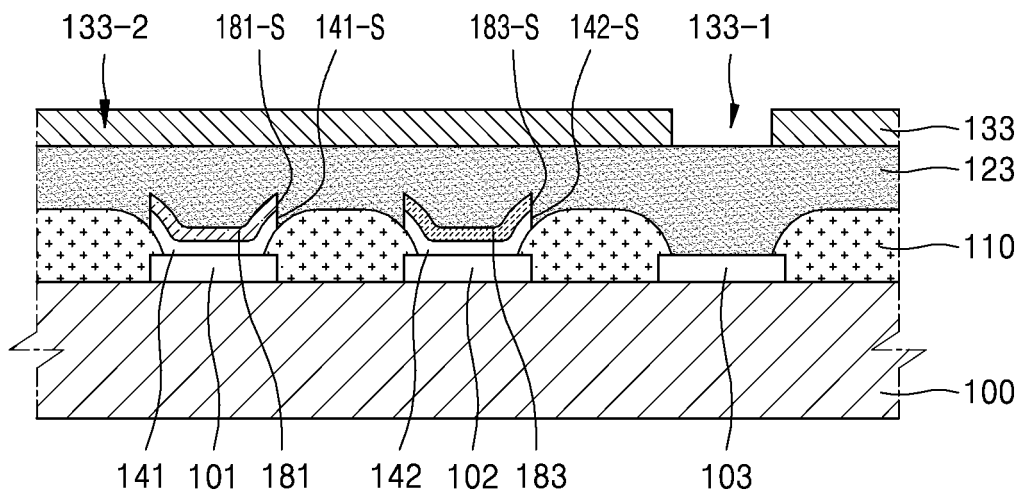

FIG. 11C

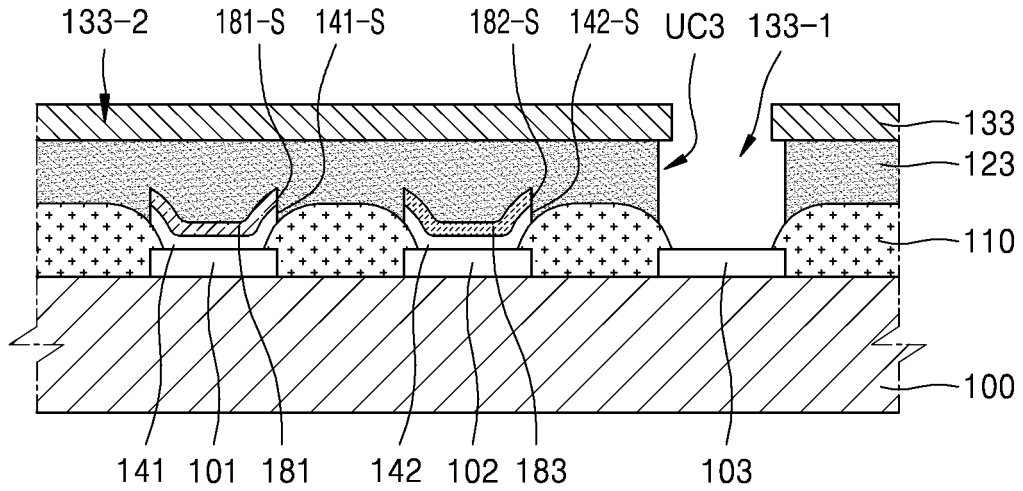

FIG. 11D

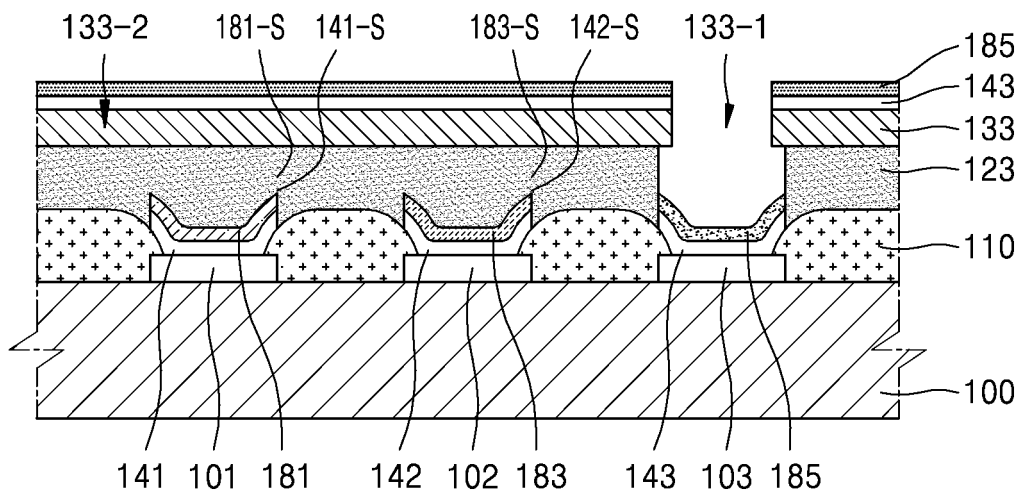

FIG. 11E

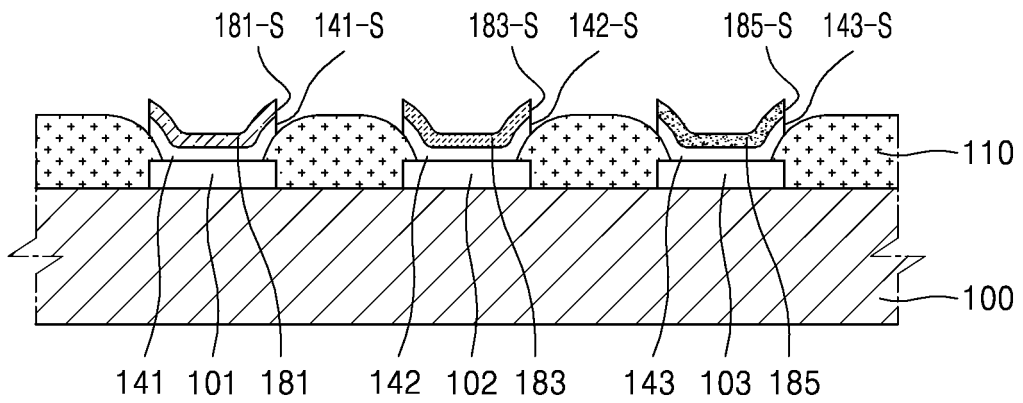
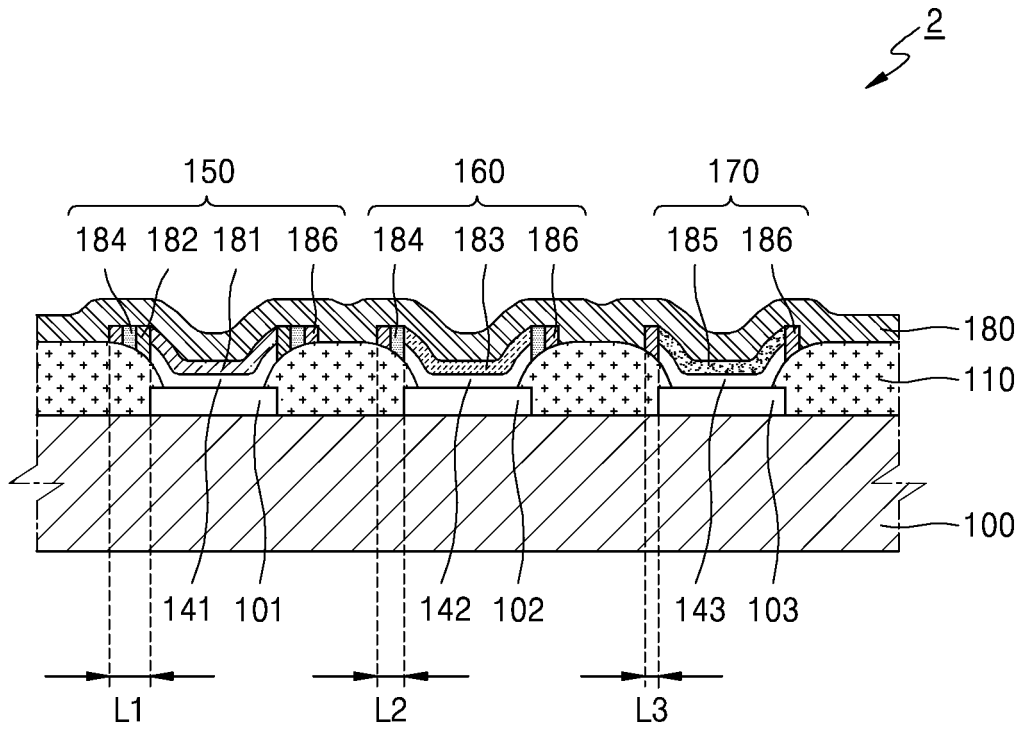

FIG. 12



REFERENCES CITED IN THE DESCRIPTION

This list of references cited by the applicant is for the reader's convenience only. It does not form part of the European patent document. Even though great care has been taken in compiling the references, errors or omissions cannot be excluded and the EPO disclaims all liability in this regard.

Patent documents cited in the description

- US 2016197297 A [0003]

专利名称(译)	有机发光显示装置及其制造方法		
公开(公告)号	EP3373356B1	公开(公告)日	2020-01-08
申请号	EP2018161325	申请日	2018-03-12
[标]申请(专利权)人(译)	三星显示有限公司		
申请(专利权)人(译)	三星DISPLAY CO. , LTD.		
当前申请(专利权)人(译)	三星DISPLAY CO. , LTD.		
[标]发明人	CHOI SHINIL YANG SUNGHOON		
发明人	CHOI, SHINIL YANG, SUNGHOON		
IPC分类号	H01L51/52		
CPC分类号	H01L27/3244 H01L51/5228 H01L2227/323 H01L27/3211 H01L51/5225 H01L51/0023 H01L51/56		
优先权	1020170030811 2017-03-10 KR		
其他公开文献	EP3373356A1		
外部链接	Espacenet		

摘要(译)

一种有机发光显示 (OLED) 装置，包括：第一电极；以及第二电极。设置在第一电极上的第一有机功能层，第一有机功能层包括第一发射层；第一相对电极，其覆盖第一有机功能层的顶表面和侧表面；与第一电极分开设置的第二电极；设置在第二电极上的第二有机功能层，第二有机功能层包括第二发射层；覆盖第二有机功能层的上表面和侧面的第二相对电极，其中覆盖第一有机功能层的侧面的第一相对电极的侧向厚度大于覆盖第二有机功能层的侧面的侧向厚度 第二有机功能层的侧面。

FIG. 1

