



(11) **EP 2 698 821 B1**

(12) **EUROPEAN PATENT SPECIFICATION**

(45) Date of publication and mention of the grant of the patent:  
**08.08.2018 Bulletin 2018/32**

(51) Int Cl.:  
**H01L 27/32** <sup>(2006.01)</sup> **G06F 3/041** <sup>(2006.01)</sup>  
**H01L 51/52** <sup>(2006.01)</sup>

(21) Application number: **12199325.7**

(22) Date of filing: **24.12.2012**

(54) **Organic light emitting display and method for manufacturing the same**

Organische lichtemittierende Anzeige und Verfahren zu ihrer Herstellung

Affichage électroluminescent organique et son procédé de fabrication

(84) Designated Contracting States:  
**AL AT BE BG CH CY CZ DE DK EE ES FI FR GB GR HR HU IE IS IT LI LT LU LV MC MK MT NL NO PL PT RO RS SE SI SK SM TR**

(30) Priority: **13.08.2012 KR 20120088540**

(43) Date of publication of application:  
**19.02.2014 Bulletin 2014/08**

(73) Proprietor: **LG Display Co., Ltd.**  
**Seoul 150-721 (KR)**

(72) Inventors:  
• **Choi, Ho-won**  
**Dalseo-gu (KR)**

• **Kim, Jin-Yeol**  
**Gyeongbuk (KR)**

(74) Representative: **Viering, Jentschura & Partner mbB**  
**Patent- und Rechtsanwälte**  
**Am Brauhaus 8**  
**01099 Dresden (DE)**

(56) References cited:  
**EP-A2- 2 423 792 US-A1- 2010 060 603**  
**US-A1- 2012 105 434**

**EP 2 698 821 B1**

Note: Within nine months of the publication of the mention of the grant of the European patent in the European Patent Bulletin, any person may give notice to the European Patent Office of opposition to that patent, in accordance with the Implementing Regulations. Notice of opposition shall not be deemed to have been filed until the opposition fee has been paid. (Art. 99(1) European Patent Convention).

**Description****FIELD**

5 **[0001]** The present invention relates to an organic light emitting display, and more particularly, to an organic light emitting display that enables realization of a thin film shape and flexibility, and exhibits superior contact properties in touch pads based on an improved structure, and a method for manufacturing the same.

**BACKGROUND**

10 **[0002]** Examples of flat panel displays include liquid crystal displays (LCDs), organic light emitting displays (OLEDs), plasma display panels (PDPs), quantum dot panels (PDPs), field emission displays (FEDs), electrophoretic displays (EPDs) and the like. These displays include a flat display panel realizing an image in common as an essential component. Such a flat display panel has a configuration in which a pair of transparent insulating substrates are joined together such that they face each other via a layer containing an inherently luminescent or polarizing material or other optical material interposed therebetween.

15 **[0003]** In accordance with the recent trend toward large-size displays, demand for flat panel displays taking a smaller space gradually increases. Of these flat panel displays, organic light emitting display technologies are being rapidly developed.

20 **[0004]** Organic light emitting displays do not require any separate light source and include an organic light emitting diode that spontaneously emits light in each pixel, to realize display. The organic light emitting displays attract much attention as next-generation displays since they advantageously do not require light sources as well as structures for assembling the light sources with a display panel, thus having advantages of decrease in thickness and weight.

25 **[0005]** When electric charges are injected into an organic film formed between an electron injection electrode (cathode) and a hole injection electrode (anode), electrons pair with holes and the pairs then decay. At this time, an organic light emitting diode emits light.

**[0006]** Meanwhile, there is an increasing demand for incorporating a touchscreen into an organic light emitting display, where a site touched by the hand or separate input element is sensed and information is transferred in response thereto. Such a touchscreen is being applied by adhesion to the outer surface of the display.

30 **[0007]** Depending on touch sense methods, a touchscreen may be of resistive, capacitive and infrared sensing types. In consideration of ease of manufacture, sensing force and the like, capacitive type touchscreens attract much attention in small models.

**[0008]** Hereinafter, a touchscreen-integrated organic light emitting display of related art will be described with reference to the annexed drawings.

35 **[0009]** FIG. 1 is a sectional view illustrating a touchscreen organic light emitting display of related art.

**[0010]** As shown in FIG. 1, the touchscreen-integrated organic light emitting display includes an organic light emitting display panel 1, a touchscreen 2 and a cover window 3 laminated in this order from the bottom and includes first and second adhesive layers 15 and 25 disposed between the respect layers.

40 **[0011]** Here, the organic light emitting display panel 1 includes a substrate, a thin film transistor array having a matrix form disposed on the substrate, and an organic light emitting diode connected to each thin film transistor of the thin film transistor array, and includes a protective film and a polarizing layer that cover the top of the organic light emitting diode. In this case, the first adhesive layer 15 corresponds to the polarizing layer of the organic light emitting display panel 1.

**[0012]** The touchscreen-integrated organic light emitting display of related art has the following disadvantages.

45 **[0013]** First, when an organic light emitting display panel and a touchscreen are independently formed, and the touchscreen is then attached to the organic light emitting display panel, the organic light emitting display panel and the touchscreen require separate glasses, thus resulting in increased hardness and thickness, and making realization of thin and flexible organic light emitting displays impossible.

**[0014]** Second, the organic light emitting display panel and the touchscreen have different panel shapes, thus making processes for forming these components complicated and thus decreasing yield and price competitiveness.

50 **[0015]** Third, if the touchscreen is configured as an in-cell type, a pad portion of the touchscreen faces an inside, that is, a side of a pad portion of an organic light emitting display panel. In this case, a bonding process is performed using a sealant including conductive balls. Herein, relatively small conductive balls may have contact defects due to difference in diameter between the normal conductive balls. Also, a compression level of conductive balls is changed depending on a pressure applied during bonding and contact defects may thus occur during the bonding process.

55 **[0016]** United States Patent Application US 2012/105434 A1 discloses a switchable three-dimensional display including a display panel and a switchable parallax barrier. The switchable parallax barrier is configured over the display panel and includes a first substrate, a second substrate, an insulating layer, a common electrode, and a light-valve layer. The first substrate has a touch-sensing circuit. The second substrate has a plurality of control electrodes and is configured

between the first substrate and the display panel. The touch-sensing circuit and the control electrodes are located between the first substrate and the second substrate. The insulating layer is configured over the first substrate and covers the touch-sensing circuit. The common electrode is configured on the insulating layer. The light-valve layer is configured between the common electrode and the control electrodes.

5 [0017] United States Patent Application US 2010/060603 A1 discloses a touch panel including: a first substrate; a second substrate disposed to face the first substrate; an annular seal material that adheres peripheries of the first substrate and the second substrate to each other so as to set a gap between the first substrate and the second substrate; first seal portions that adhere corner portions of the first substrate and the second substrate through the seal material; and second seal portions that are in connection with the first seal portions and adhere side portions of the first substrate and the second substrate through the seal material. Each of the first seal portions has a thickness which is smaller than 10 each of the second seal portions so that the substrate gap is set to be small.

[0018] European Patent Application EP 2 423 792 A2 discloses an on-cell Touch Screen Panel (TSP) Active Matrix Organic Light Emitting Diode (AMOLED) structure. The on-cell TSP AMOLED structure includes an AMOLED, a display driver for driving the AMOLED, a display driver reinforcing material positioned at an upper part of the display driver, and a window positioned at an upper part of the display driver reinforcing material, wherein a resin or Optical Clear Adhesive (OCA) is applied between an upper surface of the display driver reinforcing material and a lower surface of the window. 15

## SUMMARY

20 [0019] Accordingly, the present disclosure is directed to an organic light emitting display and a method for manufacturing the same that substantially obviate one or more problems due to limitations and disadvantages of the related art.

[0020] An object of the present disclosure is to provide an organic light emitting display that enables realization of a thin film shape and flexibility, and exhibits superior contact properties in touch pads based on an improved structure, and a method for manufacturing the same.

25 [0021] Additional advantages, objects, and features of the present disclosure will be set forth in part in the description which follows and in part will become apparent to those having ordinary skill in the art upon examination of the following or may be learned from practice of the invention. The objectives and other advantages of the present disclosure may be realized and attained by the structure particularly pointed out in the written description and claims hereof as well as the appended drawings.

30 [0022] To achieve these objects and other advantages and in accordance with the purpose of the present disclosure, as embodied and broadly described herein, provided is an organic light emitting display including the features of claim 1.

[0023] Also, the touch pad portion may include a plurality of touch pad electrodes spaced from one another, the dummy pad portion may comprise a plurality of dummy electrodes corresponding to the touch pad electrodes.

35 [0024] The conductive balls are compressed to a predetermined thickness between the touch pad portion and the dummy pad portion.

[0025] The dead region of the neighboring portion may be spaced from the sealant by a predetermined distance.

[0026] Meanwhile, the touch pad electrode may have a laminate structure including: a metal pattern; a transparent electrode pattern overlapping the metal pattern; and at least one interlayer insulating film disposed between the metal pattern and the transparent electrode pattern.

40 [0027] Here, at least one interlayer insulating film may be an organic film.

[0028] Also, the touch electrode array may include: a metal bridge formed in the same layer as the metal pattern on the second buffer layer; a plurality of first transparent channel electrodes electrically connected to the metal bridge while overlapping the metal bridge in the same layer as the transparent electrode pattern, the first transparent channel electrodes being spaced in a first direction; and a second transparent channel electrode formed in a second direction while traversing the metal bridge in the same layer as the first transparent channel electrode. 45

[0029] Also, the touch pad electrode may further include a common transparent electrode pattern that is connected to the transparent electrode pattern and overlaps the same.

[0030] In this case, the organic light emitting display may further include a common transparent electrode in the same layer as the common transparent electrode pattern such that the common transparent electrode covers the first transparent channel electrode and the second transparent channel electrode. 50

[0031] Also, the organic light emitting display may further include a first interlayer insulating film between the metal bridge and a layer of the first transparent channel electrode and the second transparent channel electrode; and a second interlayer insulating film formed between the common transparent electrode and the layer of the first transparent channel electrode and the second transparent channel electrode.

55 [0032] At least one interlayer insulating film may be removed from the dead region of the neighboring portion.

[0033] Also, the first interlayer insulating film may be removed from a region excluding the metal bridge intersecting the second transparent electrode channel and the touch pad electrode.

[0034] Meanwhile, the dummy electrode may include a gate insulating film, a gate electrode layer, an intermediate

insulating film and a source metal layer laminated on the first buffer layer.

[0035] Also, the organic light emitting display may further include a first etching stopper and a second etching stopper film formed on the back surfaces of the first buffer layer and the second buffer layer, respectively. In this case, the organic light emitting display may further include a film substrate formed on the back surface of the first etching stopper film.

[0036] Also, the organic light emitting display may further include a cover glass formed on a back surface of the second etching stopper film.

[0037] Meanwhile, the first buffer layer and the second buffer layer may have a laminate structure including a plurality of inorganic films.

[0038] Also, the film substrate may be a plastic insulating film.

[0039] Also, the first etching stopper film and the second etching stopper film may include polyimide or photoacryl.

[0040] In accordance with another aspect of the present invention, provided is a method for manufacturing an organic light emitting display in accordance with claim 13.

[0041] After the joining process, the conductive balls may be compressed to a predetermined thickness between the touch pad portion and the dummy pad portion.

[0042] After the joining process, the dead region of the touch pad portion neighboring portion may be spaced from the sealant by a predetermined distance.

[0043] The method may further include: removing the first substrate and the second substrate; and attaching a film substrate to an exposed surface of the first etching stopper film.

[0044] The removing the first substrate and the second substrate may be carried out by etching or laser-irradiating the first substrate and the second substrate.

[0045] It is to be understood that both the foregoing general description and the following detailed description of the present disclosure are exemplary and explanatory and are intended to provide further explanation of the invention as claimed.

## BRIEF DESCRIPTION OF THE DRAWINGS

[0046] The accompanying drawings, which are included to provide a further understanding of the present disclosure and are incorporated in and constitute a part of this application, illustrate embodiment(s) of the invention and simultaneously with the description serve to explain the principle of the invention. In the drawings:

FIG. 1 is a sectional view illustrating a touchscreen-integrated organic light emitting display of related art.

FIG. 2 is a plan view illustrating an organic light emitting display according to the present disclosure.

FIG. 3 is a cross-sectional view taken along the line I-I' of FIG. 2.

FIG. 4 is a graph showing distribution of conductive balls according to diameter.

FIG. 5 is a graph showing a ratio of conductive balls contacting a substrate.

FIG. 6 is a graph showing a ratio of conductive balls contacting a substrate before and after compression when conductive balls have different diameters.

FIG. 7 is a cross-sectional view illustrating a bonding process in the pad and a pad neighboring portion of FIG. 2.

FIG. 8 is a cross-sectional view illustrating a pad, a pad neighboring portion and an active region of an organic light emitting display according to a first embodiment of the present disclosure.

FIG. 9 is a cross-sectional view illustrating a pad, a pad neighboring portion and an active region of an organic light emitting display according to a second embodiment of the present disclosure.

FIG. 10 is a plan view illustrating a region "A" of FIG. 2 according to a modified embodiment of the second embodiment.

FIGs. 11A and 11B are an enlarged plan view and a sectional view illustrating a region "B" of FIG. 10, respectively.

FIG. 12 is a plan view illustrating a region "A" according to the second embodiment of the present disclosure.

FIGs. 13A and 13B are an enlarged plan view and a sectional view of a region "C" of FIG. 12, respectively.

## DETAILED DESCRIPTION

[0047] Reference will now be made in detail to the preferred embodiments of the present disclosure, examples of which are illustrated in the accompanying drawings. Wherever possible, the same reference numbers will be used throughout the drawings to refer to the same or like parts.

[0048] Hereinafter, an organic light emitting display and a method for manufacturing the same will be described in detail with reference to the annexed drawings.

[0049] An organic light emitting display according to the present disclosure has a touch sensing function and has a reduced thickness and increased flexibility. According to the present disclosure, a thin film transistor and an organic light emitting array are formed on a first substrate, whereas a touch electrode array is formed on a second substrate. The first and second substrates are joined together, followed by removing the hard and thick first and second substrates by

laser irradiation or etching to reduce thickness and to increase flexibility. In the organic light emitting display according to the present disclosure, a pad portion of the touch electrode array faces a pad portion of the organic light emitting array, and these pad portions are connected to each other via a conductive ball to allow for transfer of signals to the touch electrode array and detection of signals from the touch electrode array.

5 [0050] Hereinafter, an in-cell organic light emitting display in which a touch electrode array is provided inside a cover glass will be described.

[0051] FIG. 2 is a plan view illustrating an organic light emitting display according to the present disclosure. FIG. 3 is a cross-sectional view taken along the line I-I' of FIG. 2.

10 [0052] As shown in FIGs. 2 and 3, the organic light emitting display according to the present disclosure includes an organic light emitting array 150 and a touch electrode array 230 that are joined to each other via an adhesive layer 400. The organic light emitting array 150 and the touch electrode array 230 have different sizes, and are formed at an inside of a film substrate 1000 and at an inside of a cover glass 3000, respectively.

15 [0053] The organic light emitting array 150 and the touch electrode array 230 are not directly formed on the film substrate 1000 or the cover glass 3000. Instead, these arrays are formed by separately preparing first and second substrates (both not shown) made of glass, followed by joining the substrates via an adhesive layer disposed between the organic light emitting array 150 and the touch electrode array 230. The joining of the substrates is performed while keeping the first and second substrates. Thereafter, the first and second substrates are removed by laser irradiation or etching to achieve thin film and flexibility. In this case, as shown in FIG. 2, the first and second substrates formed of glass materials are removed and the film substrate 1000 and the cover glass 3000 are adhered to the bottom of the exposed arrays, respectively, in order to protect these arrays.

20 [0054] Here, a film adhesive layer 1100, a first etching stopper layer 120, a first buffer layer 130 and a thin film transistor array 140 and an organic light emitting array 150 are formed on the film substrate 1000 in this order. A protective layer 160 is formed to cover the organic light emitting array 150. A second etching stopper layer 210, a second buffer layer 220 and a touch electrode array 230 are disposed on the cover glass 3000. Here, the touch electrode array 230 is disposed to face the organic light emitting array 150. As shown in the illustrative embodiment, the protective layer 160 directly contacts a bottom surface of the adhesive layer 400 and the touch electrode array 230 directly contacts a top surface of the adhesive layer 400.

25 [0055] An active region and a dead region are defined in each of the first buffer layer 130 and the second buffer layer 220. The touch electrode array 230, the organic light emitting array 150 and thin film transistors present in the thin film transistor array 140 excluding a pad portion are formed in the active region. The touch electrode pad portion 2350 and the pad portion of the thin film transistor array are defined in part of the dead region.

30 [0056] The first etching stopper layer 120 and the second etching stopper layer 210 function to prevent damage to an internal array, in addition to the first and second substrates made of glass materials during laser irradiation or etching.

35 [0057] Also, the first buffer layer 130 and the second buffer layer 220 may be formed by sequentially laminating the same type of inorganic film such as an oxide film ( $\text{SiO}_2$ ) or nitride film ( $\text{SiNx}$ ), or alternatively laminating different types of inorganic films. The first and second buffer layers 130 and 220 serve as barriers to prevent permeation of moisture or exterior air into the organic light emitting array 150 after the second substrate is joined to the first substrate.

[0058] Also, both the touch pad portion 2350 and the touch electrode array 230 are formed on the same surface of the second buffer layer 220.

40 [0059] The touch pad portion 2350 is connected to the pad portion of the thin film transistor array 140 via a sealant 450 including a conductive ball 455, when the upper and lower substrates are joined to each other via the adhesive layer 400. The adhesive layer 400 functions to prevent permeation of moisture and directly contacts the protective layer 160 that covers the organic light emitting array 150, thus preventing permeation of exterior air into the organic light emitting array 150 and more certainly prevents permeation of moisture, in addition to the functions of the protective layer 160.

45 [0060] Here, the thin film transistor array 140 including the pad portion has a side that protrudes from the touch electrode array 230. This configuration aims at providing, at the protrusion, an IC 500 (not shown) that transfers a signal to simultaneously drive the touch electrode array and the thin film transistor array, and the organic light emitting array. Although not shown, the IC 500 is connected through lines (not shown) formed on the IC 500 and the first buffer layer 130 to driving pads and dummy pads of the thin film transistor array. Also, the IC 500 is bonded and connected to a flexible printed circuit board (FPCB, not shown) and may be controlled by a controller (not shown) provided in the FPCB. The dummy pad is formed in the same layer as a metal constituting a gate or data line in a region corresponding to the touch pad portion among the dead region disposed out of the active region.

50 [0061] The touch pad portion 2350 is formed on the second buffer layer 220 and is formed at both edges of the side adjacent to a portion where the first buffer layer 130 protrudes more than the second buffer layer 220. Also, the touch pad portion 2350 formed at one edge is divided into a plurality of pad electrodes to enable voltage application or detection of first electrodes arrayed in an X-axis direction in the touch electrode array, and the touch pad portion 2350 formed at the other edge is divided into a plurality of pad electrodes to enable voltage application or detection of second electrodes arrayed in an Y-axis direction.

[0062] The conductive ball 455 connected to the touch pad portion 2350 is electrically connected to a dummy electrode (not shown) formed out of the thin film transistor array 140.

[0063] Meanwhile, as shown in FIG. 3, the organic light emitting display according to the present disclosure includes a film substrate 1000, a first etching stopper film 120 and a first buffer layer 130 formed in this order on the film substrate 1000, a thin film transistor array 140 having a thin film transistor in each pixel defined in a matrix form on the first buffer layer 130, an organic light emitting array 150 connected to the thin film transistor of each pixel, a protective layer 160 that covers the thin film transistor array 140 excluding the pad portion and the organic light emitting array 150, a touch electrode array 230 adhered to the protective layer via an adhesive layer 400 interposed between the protective layer 160 and the touch electrode array 230, and a second buffer layer 220 and a second etching stopper film 210 formed in this order on the touch electrode array 230, and includes a cover glass 3000 disposed on the second etching stopper film 210.

[0064] Here, the cover glass 3000 may be adhered to the second etching stopper film 210 via an adhesive layer therebetween, or may be disposed on the second etching stopper film 210 by a mechanical method or another method. The cover glass 3000 protects internal arrays from damage caused by direct touch of a user.

[0065] The organic light emitting display according to the present disclosure can have reduced thickness by omitting a glass substrate, which has a thickness of about 0.7 mm, which is the thickest among components in the display, and which would otherwise increase the overall thickness of the organic light emitting display. Moreover, the organic light emitting can realize a bendable or flexible display by using a plastic insulating film as the film substrate 1000 to support the thin film transistor array 140, the organic light emitting array 150 and the touch electrode array 230.

[0066] In addition, in the process of forming arrays such as the thin film transistor array 140, the organic light emitting array 150 and the touch electrode array 230 on the film substrate, the film substrate may be thermally expanded by heat applied to apparatuses for depositing or patterning the arrays, thus making normal processing impossible. In order to prevent this phenomenon, formation of arrays is carried out by forming etching stopper films 120 and 210 and buffer layers 130 and 220 under the thin film transistor array 140 and the touch electrode array 230, respectively, on the glass substrate, before formation of the thin film transistor array 140 and formation of the touch electrode array 230, and then loading the glass substrate in an apparatus for deposition or patterning.

[0067] Meanwhile, the thin film transistor array 140 includes a plurality of gate lines and a plurality of data lines that intersect each other to define pixels. The thin film transistors are formed at the respective intersections between the gate lines and the data lines. A pad portion of the thin film transistor array 140 is obtained by forming a pad portion metal in the process of forming the gate and data lines.

[0068] Also, the organic light emitting array 150 includes a first electrode formed at least in the pixel, a second electrode formed in an upper layer spaced from the first electrode, and an organic light emitting layer formed between the first and second electrodes. Here, the first electrode may be connected to a drain electrode of the thin film transistor.

[0069] In addition, the first etching stopper film 120 and the second etching stopper film 210 may be for example formed of polyimide or photo-acryl.

[0070] The first and second etching stopper films 120 and 210 have a thickness of about 1  $\mu\text{m}$  to about 20  $\mu\text{m}$ .

[0071] Also, the first buffer layer 130 and the second buffer layer 220 function to prevent permeation of oxygen or moisture into organic films provided in the organic light emitting array and serve as barriers to prevent permeation of exterior air or moisture injected from a lower part.

[0072] The first buffer layer 130 and the second buffer layer 220 include a plurality of inorganic films. For example, the inorganic films may be formed by continuously or alternatively laminating  $\text{SiN}_x$  or  $\text{SiO}_2$ . It can be seen from experimentation that, when two or more layers are laminated to a thickness of about 5,000Å to 6,500Å as the first and second buffer layers 130 and 220, permeation of exterior air or moisture can be prevented. A total thickness of the first and second buffer layers 130 and 220 is 1  $\mu\text{m}$  or less, which does not increase the thickness of the touchscreen-integrated display device.

[0073] The touch electrode array 230 includes a first transparent channel electrode (not shown) and a second transparent channel electrode (not shown) that intersect each other, and a touch pad (provided in a touch pad portion) to transfer a signal to the first and second transparent channel electrodes. A thin film transistor array including the dummy metal is shown in FIG. 3 and a touch electrode layer is shown in the form of a single layer including the touch pad, and the first and second transparent channel electrodes, but these layers are patterned according to respective electrodes.

[0074] Here, the first and second transparent channel electrodes are formed of a transparent electrode, the touch pad includes a metal pad layer that has high conductivity and superior light-shielding properties (the same layer as the metal bridge), and a transparent electrode pattern which is the same layer as the transparent electrode constituting the first and second transparent channel electrodes. Also, the first and second transparent channel electrodes may be disposed in the same layer or different layers. For example, when the first and second transparent channel electrodes are present in the same layer, a separate metal bridge that contacts the first transparent channel electrodes or the second transparent channel electrodes adjacent to other layers is provided at the intersection between the first and second transparent channel electrodes, to prevent short-circuit between the first and second transparent channel electrodes.

[0075] In the in-cell organic light emitting display described above, contact between the touch pad portion and the dummy pad portion formed in the thin film transistor array via conductive balls may be difficult or defective due to difference in diameter between conductive balls 455 or pressure applied during a bonding process, thus undesirably increasing resistance.

5 [0076] FIG. 4 is a graph showing distribution of conductive balls according to diameter.

[0077] For example, conductive balls (particles) having a mean diameter of 7  $\mu\text{m}$ , as shown in FIG. 4, may have a diameter distribution in the range of about 6  $\mu\text{m}$  to 8  $\mu\text{m}$ , due to manufacturing tolerance during the formation of conductive balls.

10 [0078] FIG. 5 is a graph showing a ratio of conductive balls contacting a substrate. FIG. 6 is a graph showing a ratio of conductive balls contacting a substrate before and after compression when there is a difference in diameter between conductive balls.

[0079] As can be seen from FIG. 6, the conductive balls are elastic and a contact area between the conductive balls and the substrate is thus varied depending on applied pressure. As the applied pressure increases, the contact area between the conductive balls and the substrate increases.

15 [0080] As can be seen from FIG. 6, in particular, when a plurality of conductive balls 55 having different diameters are formed on the substrate 10, if no pressure is applied to the substrate 10 or a counter substrate 20 disposed opposite to the substrate 10, only conductive balls having a large diameter contact the counter substrate 20. However, when a compressive force of 10% or more is applied thereto, conductive balls having a small diameter also contact the counter substrate 20.

20 [0081] This means that a predetermined pressure or more is required so that all conductive balls contact an opposite pad portion during the bonding process due to difference in diameter between the conductive balls. However, there is a limitation on arbitrary increase in applied pressure, since the pressure applied during bonding is predetermined and pattern stability in the active region should be considered.

25 [0082] Hereinafter, how to avoid contact defects through structural change in the organic light emitting display of the present disclosure will be described.

[0083] FIG. 7 is a cross-sectional view illustrating a bonding process in the pad and a pad neighboring portion of FIG. 2. FIG. 7 illustrates an organic light emitting display including an in-cell type touch electrode array according to one embodiment of the present invention. Considering the pad electrode and the pad electrode neighboring portion, a step between upper and lower parts occurs in a region corresponding to a sealant 450.

30 [0084] FIG. 7 illustrates a bonding process. The first and second substrates 100 and 300 made of a glass component remain un-removed on the rear surface of the first etching stopper film 120 and the second etching stopper film 210, respectively. That is, the bonding process is performed under the condition that the glass substrate is not removed. After the touch pad electrode is bonded to the dummy electrode of the thin film transistor array, the first and second substrates 100 and 300 are removed.

35 [0085] Regarding a substantial lamination order, an amorphous semiconductor layer 110, a first etching stopper film 120, a first buffer layer 130, a thin film transistor array 140 and an organic light emitting device array 150 are sequentially formed on the first substrate 100. In the drawing, excluding an active region, only the pad electrode portion and the pad electrode neighboring portion are present and the organic light emitting device array 150 is omitted.

40 [0086] As shown in FIG. 7, the touch pad electrode 2351a includes a metal pattern 231a in the same process as the metal bridge of the touch electrode array 230, and a transparent electrode pattern 233a and a common transparent electrode pattern 235a formed in the same process as the first and second transparent channel electrodes. That is, the touch pad electrode 2351a is formed by laminating a metal formed during three different processes and at least one transparent electrode pattern.

45 [0087] In this case, the pad electrode neighboring portion is not provided with an electrode and includes the second interlayer insulating film 234 in the active region. Also, the second interlayer insulating film 234 is an organic film.

[0088] In this regard, the metal pattern 231a has a thickness of about 1,000 to about 3,000Å, and the transparent electrode pattern 233a and the common transparent electrode pattern 235a have a considerably small thickness of about 300 to about 800Å and about 75 to about 250Å, respectively. The thickness of the common transparent electrode pattern 2351a having a laminate structure including three layers is smaller than the thickness (2 to 3  $\mu\text{m}$ ) of the second interlayer insulating film 234 formed of an organic film 234. As a result, a distance "b" is present between the outermost surface of the touch pad electrode 2351a and the conductive ball 455 present in the sealant 450. This distance between the conductive ball 455 and the touch pad electrode 2351a may make electric contact between the pad electrode 2351a and the dummy electrode 1400 impossible.

50 [0089] Meanwhile, the dummy electrode 1400 includes a gate insulating film 141, a gate electrode layer 142, an intermediate insulating film 143 and a source metal layer 144 which are laminated on a first buffer layer 130.

55 [0090] The source metal layer 144 is removed from the neighboring portion of the dummy electrode 1400 to expose the intermediate insulating film 143. As a result, a distance "a" is present between the exposed intermediate insulating film 143 and the sealant 450.

**[0091]** However, as shown in FIG. 7, since the distance "b" between the afore-mentioned pad electrode 2351a and the sealant 450 is larger than the distance "a" due to the thickness of the second interlayer insulating film 234, the conductive balls 455 may be spaced from the pad electrode 2351a by applying a predetermined pressure, making the distance "a" zero. In this case, a contact defect occurs.

**[0092]** In the test of the present disclosure, when the second interlayer insulating film 234 has a thickness of about  $2.1\ \mu\text{m}$ , the metal pattern 231a, the transparent electrode pattern 233a and the common transparent electrode pattern 235a have thicknesses of 2000A, 500A and 125A, respectively, the distance "b" is an about  $1.8\ \mu\text{m}$ , and the distance "a" between the thin film transistor array 140 corresponding to the pad electrode neighboring portion and the sealant 450 is 3,000A, as a result of removal of the source metal layer 144. In this case, a pressure should be applied so that the conductive ball 445 is compressed to a thickness of  $1.5\ \mu\text{m}$  or more and thus contacts the dummy electrode 1400 and the touch pad electrode 2351a. Also, in consideration of difference between the conductive balls 445, a pressure should be applied so that each conductive ball is compressed to a thickness of  $1.5\ \mu\text{m}$  or more. When the pressure is insufficient, contact defects may occur in the structure shown in FIG. 7.

**[0093]** In this regard, there is a limitation on the amount of pressure applied during the bonding process. Accordingly, the organic light emitting display of the present disclosure improves electric contact between the conductive ball, and the pad electrode and the dummy electrode, and this configuration will be described in detail.

**[0094]** In the following drawings, the layers constituting the touch electrode array are not drawn to scale and are shown to have similar thicknesses. Generally, the interlayer insulating film has the largest thickness of about  $1.5\ \mu\text{m}$  to about  $4\ \mu\text{m}$  among the layers constituting the array and the metal layer has a thickness of about 2,000A to about 4,000A. The transparent electrode layer has a thickness of about 300 to about 800A, and the common transparent electrode layer has a thickness of about 75 to 250A. That is, the layers have different thickness. However, as shown in the drawings, the layers formed in common in the pad electrode, the pad electrode neighboring portion and the active region cause no step between regions and the respective layers are shown to have similar thickness.

**[0095]** FIG. 8 is a cross-sectional view illustrating a pad, a pad neighboring portion and an active region of an organic light emitting display according to a first embodiment of the present invention.

**[0096]** A state immediately after bonding is shown in the cross-sectional views of FIGs. 8 and 9. The second substrate 300 and the first substrate 100 disposed in upper and lower parts still remain unremoved.

**[0097]** As shown in FIG. 8, the organic light emitting display according to the first embodiment of the present invention includes a first buffer layer 130 and a second buffer layer 220 which include an active region and a dead region and face each other, a thin film transistor array 140 including a thin film transistor in each of pixels defined in a matrix form in the active region of the first buffer layer 130, an organic light emitting array 150 including an organic light emitting diode connected to the thin film transistor of each pixel, a protective layer 160 formed on the first buffer layer 130 such that it covers the thin film transistor array 140 and the organic light emitting array 150, a touch electrode array 230 formed in the active region of the second buffer layer 220, an adhesive layer 400, the top and bottom of which contact the protective layer 160 and the touch electrode array 230, respectively, a touch pad portion (represented by "2350" in FIG. 2) formed in a predetermined part of the dead region of the second buffer layer 220, a dummy pad portion formed in the dead region of the first buffer layer 130 such that it faces the touch pad portion, and a sealant 450 including a plurality of conductive balls 455 positioned between the touch pad portion and the dummy pad portion.

**[0098]** Also, the touch pad portion includes a plurality of touch pads 2351b, and the dummy pad portion includes dummy electrodes 1400 corresponding to the touch pads 2351b.

**[0099]** Here, a distance between the uppermost surface of the touch pad electrode 2351b and the uppermost surface of the dummy electrode 1400 in the pad portion is smaller than the distance in the neighboring portion. In the drawing, the distance of the pad electrode is "a+c" smaller than that of the pad electrode neighboring portion.

**[0100]** In this case, the first distance "a" represents a distance between the sealant 450 and the thin film transistor array 140. The first distance "a" is formed as a result of removal of the source metal layer 144 from the pad electrode neighboring portion of the thin film transistor array 140. The second distance "c" represents a distance between the second interlayer insulating film 234 and the sealant 450 in the pad electrode neighboring portion.

**[0101]** In the first embodiment, a first interlayer insulating film 232 corresponding to the touch pad electrode is further provided, although the second interlayer insulating film 234 included in the pad electrode neighboring portion adjacent thereto is thicker than the metal layer or the transparent electrode layers. The first interlayer insulating film 232 having a similar thickness to the second interlayer insulating film 232 is also provided in the touch pad electrode 2351b. The touch pad electrode 2351b is thus formed to have a step higher than the neighboring portion.

**[0102]** That is, the touch pad portion includes a plurality of touch pad electrode 2351bs two-dimensionally spaced from one another. Each touch pad electrode 2351b further includes the first interlayer insulating film 232 interposed between the metal pattern 231a and the transparent electrode pattern 233a, in addition to the metal pattern 231a, the transparent electrode pattern 233a and the common transparent electrode pattern 235a, along a vertical direction, in order to increase the height of the step. In FIG. 7, only one first interlayer insulating film 232 is interposed between the electrode layer and the transparent electrode pattern, but the present disclosure is not limited to this structure. That is,

two or more interlayer insulating films can be further provided to maximize a step between the pad electrode and the pad electrode neighboring portion. Here, the interlayer insulating film included in the touch pad electrode 2351a may be formed during formation of the touch electrode array 230, which is a component that may be formed without an additional process.

5 [0103] Here, only a part of the touch pad electrode 2351b is shown. A contact hole is provided in a part of the first interlayer insulating film 232 between the metal pattern 231a and the transparent electrode pattern 233a, thus enabling electric contact.

[0104] Meanwhile, the dummy electrode 1400 has a configuration in which a gate insulating film 141, a gate electrode layer 142, an intermediate insulating film 143 and a source metal layer 144 are laminated in this order on the first buffer layer 130.

10 [0105] The conductive ball 455 in the sealant 450 is connected to the upper and lower touch pads 2351b and the dummy electrode 1400 even upon application of low pressure during the bonding process, since the touch pad neighboring portion has an "a+c" greater distance than the touch pad, thus improving contact characteristics. As a result, after the bonding process, the conductive ball 455 is pressed to a predetermined thickness between the touch pad portion and the dummy pad portion. This structure causes a decrease in contact resistance, improvement in contact characteristics and thus improvement in touch signal sensitivity.

[0106] In this case, a second distance "c" is present between the second interlayer insulating film 234 and the sealant 450 in the dead region of the touch pad neighboring portion, and a first distance "a" is present between the intermediate insulating film 143 and the sealant 450 in the dummy electrode neighboring portion.

20 [0107] Meanwhile, one or more interlayer insulating films 234 and 232 are preferably organic films. This aims at providing interlayer insulation between the electrode layer and the transparent electrode pattern in the touch electrode array 230 and securing a predetermined thickness between the metal layer and the transparent electrode pattern which are different layers.

[0108] A flat layer 145 may be further provided on the outermost surface of the thin film transistor array 140 in the active region.

25 [0109] Also, the touch electrode array 230 of the active region includes the metal bridge 231 formed in the same layer as the metal pad layer 231a on the second buffer layer, a plurality of first transparent channel electrodes (represented by "2331" in FIG. 10) which are electrically connected to the metal bridge 231 while overlapping the metal bridge 231 and are spaced from one another in a first direction in the same layer as the transparent electrode pattern 233a, and a transparent metal layer 233 that includes a second transparent channel electrode 2332 that traverses the metal bridge and is formed in a second direction in the same layer as the first transparent channel electrode.

30 [0110] In the illustrated drawing, a common transparent electrode 235 overlaps the transparent metal layer 233 and the second interlayer insulating film 234 constituting the first and second transparent channel electrodes. If desired, the common transparent electrode 235 may be omitted. The common transparent electrode 235 is a floating state which functions to shield effects of driving signals of the thin film transistor array or the organic light emitting array that faces the same on the touch electrode array 230.

35 [0111] In this case, the touch pad 2351a of the touch pad portion may also further include a common transparent electrode pattern 235a that overlaps the transparent electrode pattern 233a and is connected to the transparent electrode pattern 233a.

40 [0112] Here, in the dead region of the touch pad neighboring portion, at least one interlayer insulating film (in the drawing, first interlayer insulating film) may be removed.

[0113] Meanwhile, reference numeral "145" represents a passivation layer 145 formed on the outermost surface of the thin film transistor array 140 in the active region.

45 [0114] Also, the organic light emitting array 150 includes an anode 151, an organic light emitting layer 152 and a cathode 153. This configuration is a minimal unit. A bank (not shown) may be included between pixels in order to isolate the organic light emitting layer 152 into pixel units, and an organic layer may be added or changed in order to improve luminous efficacy between the anode 151 and the cathode 153.

[0115] Also, first and second etching stopper films 120 and 210 may be formed on the bottom of the first buffer layer 130 and the second buffer layer 220, respectively. The first etching stopper film 120 and the second etching stopper film 210 may be polyimide or photoacryl.

50 [0116] In this case, after the bonding process, a film substrate (represented by "1000" in FIG. 2) may be further formed on the bottom of the first etching stopper film 120. Here, the film substrate 1000 may be formed of a plastic insulating film for realization of thinness and flexibility.

[0117] Also, after removal of the substrate (glass), a cover glass (represented by "3000" in FIG. 2) may be further formed on the second etching stopper film 210.

55 [0118] Meanwhile, the first buffer layer 130 and the second buffer layer 220 may have a laminate structure including a plurality of inorganic films.

[0119] Also, the protective layer 160 includes an inorganic film 161, an organic film 162 and an inorganic film 163

which are laminated in this order. Based on the structure including organic and inorganic films which are alternately laminated, the protective layer 160 primarily functions to prevent permeation of moisture into the organic light emitting array 150.

**[0120]** Also, reference numerals "205" and "110" represent a nitride layer and an amorphous semiconductor layer, respectively, to protect arrays. These layers may be removed together with the adjacent substrate during removal of the glass after the bonding process.

**[0121]** Hereinafter, a second embodiment of the present invention will be described.

**[0122]** FIG. 9 is a cross-sectional view illustrating a pad, a pad neighboring portion and an active region of an organic light emitting display according to a second embodiment of the present invention.

**[0123]** In comparison with the first embodiment, the organic light emitting display according to the second embodiment is characterized in that the pad electrode further includes a second interlayer insulating film 234 between the transparent electrode pattern 233a and the common transparent electrode pattern 235a overlapping the transparent electrode pattern 233a.

**[0124]** In this case, in comparison with the pad electrode neighboring portion, the pad electrode further includes the metal pattern 231a, the second interlayer insulating film 232, the transparent electrode pattern 233a and the common transparent electrode pattern 235a. The total thickness of these layers in the pad electrode corresponds to a third distance "d" and thus is higher than the pad electrode neighboring portion. Accordingly, as compared to the first embodiment, the second embodiment exhibits superior contact properties between the touch pad electrode 2351a of the conductive ball 455 and the dummy electrode 1400 after bonding.

**[0125]** Also, the first interlayer insulating film 232 is omitted in the active region and a step of the uppermost surface of the active region can thus be decreased. In this case, when the protective layer 160 covering the organic light emitting array 150 contacts the dummy pad electrode 1400 through the sealant 450 including the adhesive layer 400 and the conductive balls 455, the touch pad electrode 2351a having a higher step can easily contact the sealant 455, as compared to other regions and thus exhibits improved contact properties.

**[0126]** Regardless of whether the first interlayer insulating film 232 is removed from the active region, the touch pad electrode neighboring portion has a lower step than the touch pad electrode and thus exhibits improved contact properties.

**[0127]** When the first interlayer insulating film 232 is removed from the active region, the first metal bridge 231 provided with the thin film transistor array 140 directly contacts the first transparent channel electrode of the transparent electrode layer 233. In this case, in order to prevent short-circuit between the first metal bridge 231 and the first transparent channel electrode, the first interlayer insulating film 232 may be provided on the first metal bridge 231 excluding a contact site between first transparent channel electrodes disposed at both sides of the first metal bridge 231.

**[0128]** Hereinafter, a modified embodiment of the second embodiment and a detailed description thereof will be described.

**[0129]** FIG. 10 is a plan view illustrating a region "A" of FIG. 2 according to a modified embodiment of the second embodiment. FIGs. 11A and 11B are an enlarged plan view and a cross-sectional view illustrating a region "B" of FIG. 10, respectively.

**[0130]** The modified embodiment of the second embodiment according to the present disclosure illustrates a configuration in which the first interlayer insulating film 232 is omitted in the neighboring portion of the touch pad portion 2350. That is, the first interlayer insulating film 232 is formed in the active region and the touch pad portion 2350.

**[0131]** Specifically, referring to FIG. 11A which is an enlarged view of a region "B" of FIG. 10, the metal bridge 231 of the active region is shown. Also as shown in FIG. 11B, first transparent channel electrodes 2331 are spaced from one another in an island form. A second transparent channel electrode connection portion 2332c between first transparent channel electrodes 2331 is disposed in a vertical direction. A second transparent channel electrode 2332 has a diamond shape integrated therewith.

**[0132]** Here, the first transparent channel electrode 2331, the second transparent channel electrode 2332 and the second transparent channel electrode connection portion 2332c are formed by patterning the transparent electrode layer disposed in the same layer. The first transparent channel electrode 2331 is connected to the metal bridge 231 through a contact hole 232a interposed between the first interlayer insulating film 232 and the metal bridge 231.

**[0133]** Also, the second interlayer insulating film 234 that covers the first transparent channel electrode 2331, the second transparent channel electrode connection portion 2332c and the second transparent channel electrode 2332 is formed. A common transparent electrode 2335 having a width larger than the first transparent channel electrode 2331 and the second transparent channel electrode 2332 and the second transparent channel electrode connection portion 2332c integrated with each other is formed on the second interlayer insulating film 234.

**[0134]** Here, the common transparent electrode 2335 is not connected to the pad electrode and is provided as a floating state which functions to shield effects of driving of the organic light emitting array disposed thereunder, when the touch electrode array and the organic light emitting array are joined to each other using an adhesive layer 400. If desired, the common transparent electrode 2335 may be omitted.

**[0135]** As shown in FIG. 10, reference numeral "231b" represents a routing line formed together with the metal bridge

231 and is a line to transfer a signal between the first transparent channel electrode 2331 and the touch pad electrode 2351b of each line. Reference numeral "231c" also represents a line formed in the same layer as the metal bridge 231 and the second substrate (removed after bonding), the second transparent channel electrode 2332 of each row and the touch pad electrode (2351b, provided in a touch pad portion formed at one side of the substrate, based on FIG. 2).

5 **[0136]** FIG. 12 is a plan view illustrating a region "A" according to the second embodiment of the present invention. FIGs. 13A and 13B are an enlarged plan view and a cross-sectional view of a region "C" of FIG. 12, respectively.

**[0137]** As shown in FIGs. 12 to 13B, according to the second embodiment of the present invention, the first interlayer insulating film 232 is removed from the active region, excluding a region where the second transparent channel electrode connection portion 2332c overlaps the metal bridge 231. In this case, the contact hole is not provided in the first interlayer

10 **[0138]** Also, the first interlayer insulating film 2232 is selectively formed only in regions where the touch pad portion 2350 overlaps the metal bridge 231.

**[0139]** Accordingly, as shown in FIG. 13B, due to selective omission of the first interlayer insulating film 2332, the top of the first transparent channel electrode 2331 (the top of the second transparent channel electrode 2332 has a lower step) has a lower step than the central region of the metal bridge 231.

15 **[0140]** Also, the first interlayer insulating film 2232 is omitted from the active region and the step of the outermost surface of the active region can thus be lowered. In this case, when a protective layer 160 covering the organic light emitting array 150 contacts the dummy pad electrode 1400 through the sealant 450 including the adhesive layer 400 and the conductive ball 455, the touch pad electrode 2351c in the touch pad portion 2350 having a relatively high step

20 **[0141]** Hereinafter, with reference to FIGs. 2, 3, 8, 10, 11A and 11B, a method for fabricating the organic light emitting display of the present disclosure will be described.

**[0142]** First, an amorphous semiconductor layer 110, a first etching stopper film 120 and a first buffer layer 130 are formed on a first substrate 100, a thin film transistor array 140 including a thin film transistor in each of pixels defined as a matrix form, an organic light emitting array 150 including an organic light emitting diode connected to the thin film transistor of each pixel, and a protective layer 160 formed on the first buffer layer 130 such that it covers the thin film transistor array 140 and the organic light emitting array 150 are formed in the active region of the first buffer layer 130. A dummy pad portion including a plurality of dummy pads 1400 spaced from one another is formed in a part of the dead region of the first buffer layer 130.

25 **[0143]** Subsequently, a nitride film 205, a second etching stopper film 210 and a second buffer layer 220 are formed on a second substrate 300, the touch electrode array 230 is formed in the active region of the second buffer layer 220, and a touch pad portion 2350 including a plurality of touch pad electrodes (2351b or 2351c) spaced from one another are formed in a region corresponding to the dummy pad portion. In this process, the configuration is designed such that the distance between the outermost surface of the touch pad portion 2350 and the outermost surface of the dummy pad portion is smaller than that of the neighboring portion.

30 **[0144]** Subsequently, a sealant 450 including conductive balls 455 is applied to the touch pad portion 2350 or dummy pad portion and an adhesive layer 400 is applied to the touch electrode array 230 or the protective layer 160 and a joining process is performed. During the joining process, the distance between the outmost surface of the touch pad portion 2350 and the dummy pad portion of the pad electrode portion is smaller than that of the neighboring portion, making connection between upper and lower pad portions through conductive balls sufficient.

35 **[0145]** In this case, after joining, the conductive balls may be pressed to a predetermined thickness between the touch pad portion and the dummy pad portion.

**[0146]** Also, after the joining process, the dead region of the touch pad portion neighboring portion may be spaced from the sealant by a predetermined distance.

40 **[0147]** Also, after the joining process, the method may further include removing the first substrate 100 and the second substrate 300 and adhering a film substrate 1000 via a film adhesion layer 1100 to the exposed surface of the first etching stopper film 120.

**[0148]** Here, the first substrate 100 and the second substrate 300 may be removed by etching or laser-irradiating the first substrate 100 and the second substrate 300.

45 **[0149]** Hereinafter, Tables 1 to 4 show pressing levels of conductive balls of the configurations of FIGs. 7, 8 and 9 and a modified embodiment of the second embodiment, a configuration shown in FIGs. 10 to 11B.

**[0150]** Total numbers of conductive balls (AuB) used for structures of respective embodiments are different. A share of a pressing level with respect to a total number of conductive balls for respective embodiments is important. As shown in FIGs. 3 to 5, contact properties are improved depending on pressing level. That is, when a thickness, to which

50 **[0151]** In the following test, the diameter of the conductive balls is about 50  $\mu\text{m}$ .

TABLE 1

Conditions	AuB pressing range (um)	The number of AuB (EA)	Share (%)	Total number of AuB (EA)
Structure of FIG. 7	10 or less	887	70	1263
	10 to 15	128	10	
	16 to 20	204	16	
	20 or more	44	3	

[0152] As can be seen from Table 1 above, in the configuration shown in FIG. 7, a diameter range of conductive balls having the highest share of 70% among conductive balls is 10  $\mu\text{m}$  or less.

TABLE 2

Conditions	AuB pressing range (um)	The number of AuB (EA)	Share (%)	Total number of AuB (EA)
First embodiment	10 or less	188	31	609
	10 to 15	131	22	
	16 to 20	207	34	
	20 or more	83	14	

[0153] As compared to the structure of FIG. 7 shown in Table 1 above, the first embodiment shown in FIG. 8 has a decreased share at 10  $\mu\text{m}$  or less of 31%, and increased pressing levels at 10 to 15  $\mu\text{m}$ , 16 to 20  $\mu\text{m}$ , and 20  $\mu\text{m}$  or more. This means considerable improvement in pressing properties in all cases. Here, a share at 10  $\mu\text{m}$  or less of 31% is caused by difference in diameter between the conductive balls. When taking into consideration the fact that a plurality of conductive balls correspond to each pad electrode, contact defects can be prevented and contact resistance can be improved.

TABLE 3

Conditions	AuB pressing range (um)	The number of AuB (EA)	Share (%)	Total number of AuB (EA)
Second embodiment	10 or less	98	25	397
	10 to 15	25	6	
	16 to 20	89	22	
	20 or more	185	47	

[0154] As can be seen from FIG. 9, the second embodiment exhibits better pressing properties than the first embodiment. A pressing range having the highest share is 0  $\mu\text{m}$  or more and has a share of about 47%. Also, a pressing level of 10  $\mu\text{m}$  or less is 25% or less, the conductive balls of the second embodiment exhibit better contact properties than those of the afore-mentioned first embodiment.

TABLE 4

Conditions	AuB pressing range (um)	The number of AuB (EA)	Share (%)	Total number of AuB (EA)
Modified embodiment of second embodiment	10 or less	248	26	956
	10 to 15	202	21	
	16 to 20	334	35	
	20 or more	172	18	

[0155] As shown in Table 4, the modified embodiment of the second embodiment exhibits a pressing level of 10  $\mu\text{m}$  or less of 26% or less which is similar to the second embodiment and conductive balls of the modified embodiment

exhibit better than those of the first embodiment.

[0156] That is, as can be seen from these tests, according to the embodiments of the present invention, when the touch pad electrode has a higher step or the active region and the neighboring portion of touch pad electrode has a lower step, a pressing level of conductive balls increases, contact properties between upper and lower pad portions are improved and contact resistance is reduced.

[0157] This structure in which the touch pad electrode has a higher step than the neighboring portion improves contact properties and thus in-cell performance.

[0158] The organic light emitting display of the present disclosure and the method for manufacturing the same have the following advantages.

[0159] First, by changing a vertical configuration of the touch pad portion or the neighboring portion in an in-cell structure having a touch electrode array inside a cover glass, a distance between the touch pad portion and the thin film transistor array pad portion is decreased, as compared to a distance between other region and the thin film transistor array pad portion, and conductive balls thus contact upper and lower pad portions within a sufficiently decreased distance although there is a difference in diameter between conductive balls.

[0160] Second, a vertical distance between the touch pad portion and the thin film transistor array pad portion is decreased and compression properties of conductive balls during the bonding process can thus be improved. Accordingly, contact resistance is reduced and an in-cell structure with excellent touch sensitivity can thus be realized.

[0161] Third, since the touch pad portion is provided on an inner surface of the cover glass, the touch pad portion is connected to the thin film transistor pad portion through conductive balls. All of the touch electrode array, the thin film transistor array, and the organic light emitting array can transfer signals through one chip included in the thin film transistor pad portion. One chip is connected to one flexible printed board, thus simplifying a pad portion and circuit configurations of the organic light emitting display. As a result, slimness and cost reduction can be realized.

[0162] Fourth, the organic light emitting display according to the present disclosure has an in-cell structure in which the touch electrode array is directly formed on an inner surface of the cover glass, thus requiring no additional process for attaching a touch screen, enabling slimness and realizing displays manufactured in a simple process.

[0163] Fifth, a thin film transistor array and an organic light emitting array are formed on a first glass substrate, a touch electrode array is formed on a second glass substrate and the organic light emitting display array is joined to the touch electrode array such that these arrays face each other. Then, hard glass substrates at both sides are removed, and a plastic film is attached to one side of an exposed surface, thus resulting in thinness and flexibility of displays. Displays can have a reduced thickness and increased flexibility by omitting the glass substrate having the highest thickness.

[0164] It will be apparent to those skilled in the art that various modifications and variations can be made in the present invention without departing from the scope of the inventions. Thus, it is intended that the present invention covers the modifications and variations of this invention provided they come within the scope of the appended claims.

## Claims

### 1. An organic light emitting display comprising:

a first moisture or air prevention buffer layer (130) and a second moisture or air prevention buffer layer (220), each having a front surface and a back surface, and an active region and a dead region, wherein the front surface of the first buffer layer (130) faces the front surface of the second buffer layer (220);

a thin film transistor array (140) including a thin film transistor in each of a plurality of pixels defined in a matrix form at the active region on the front surface of the first buffer layer (130);

a touch electrode array (230) formed at the active region on the front surface of the second buffer layer (220); an organic light emitting diode (150) connected to each thin film transistor at each pixel and disposed between the touch electrode array (230) and the active region of the first buffer layer (130);

a touch pad portion (2350) formed on a part of the dead region of the second buffer layer (220), wherein the touch pad portion (2350) is formed on the front surface of the second buffer layer (220);

a dummy pad portion facing the touch pad portion (2350) at the dead region on the front surface of the first buffer layer (130); and

a sealant (450) including a plurality of conductive balls (455) between the touch pad portion (2350) and the dummy pad portion,

wherein the conductive balls (455) are compressed to a predetermined thickness between the touch pad portion (2350) and the dummy pad portion, wherein the conductive balls connect the touch pad portion (2350) and the dummy pad portion to each other, and

wherein the vertical distance between the outermost surface of the touch pad portion (2350) and the outermost surface of the dummy pad portion is smaller than the vertical distance between the outermost surface of a

neighboring portion adjacent to the touch pad portion in the dead region and the outermost surface of a neighboring portion adjacent to the dummy pad portion in the dead region.

2. The organic light emitting display according to claim 1,  
 5 wherein the touch pad portion (230) comprises a plurality of touch pad electrodes (2351a, 2351b, 2351c) spaced from one another, and  
 wherein the dummy pad portion comprises a plurality of dummy electrodes (1400) corresponding to the touch pad electrodes (2351a, 2351b, 2351c), wherein preferably each dummy electrode (1400) comprises a gate insulating film (141), a gate electrode layer (142), an intermediate insulating film (143) and a source metal layer (144) laminated  
 10 on the first buffer layer (130).
3. The organic light emitting display according to claim 1 or 2,  
 wherein preferably the neighboring portions oppose each other and at least one of the neighboring portions is spaced  
 15 from the sealant (450) in the dead region by a predetermined distance.
4. The organic light emitting display according to claim 2,  
 wherein the touch pad electrode (2351a, 2351b, 2351c) has a laminate structure comprising: a metal pattern (231a);  
 a transparent electrode pattern (233a) overlapping the metal pattern (231a); and at least one interlayer insulating  
 20 film (232) disposed between the metal pattern (231a) and the transparent electrode pattern (233a),  
 wherein preferably the at least one interlayer insulating film (232) is an organic film, wherein further preferably the  
 at least one interlayer insulating film (232) is removed from the dead region of at least one of the neighboring portions.
5. The organic light emitting display according to claim 4, wherein the touch electrode array (230) comprises:  
 25 a metal bridge (231) formed in the same layer as the metal pattern (231a) on the second buffer layer (220);  
 a plurality of first transparent channel electrodes (2331) electrically connected to the metal bridge (231) while  
 overlapping the metal bridge (231) in the same layer as the transparent electrode pattern (233a), the first  
 transparent channel electrodes (2331) being spaced in a first direction; and  
 30 a second transparent channel electrode (2332) formed in a second direction while traversing the metal bridge  
 (231) in the same layer as the first transparent channel electrode (2331).
6. The organic light emitting display according to claim 5, wherein the touch pad electrode (2351a, 2351b, 2351c)  
 further comprises a common transparent electrode pattern (235a) that is connected to the transparent electrode  
 35 pattern (233a) and overlaps the same.
7. The organic light emitting display according to claim 6, further comprising a common transparent electrode (235) in  
 the same layer as the common transparent electrode pattern (25a) such that the common transparent electrode  
 (235) covers the first transparent channel electrode (2331) and the second transparent channel electrode (2332).
8. The organic light emitting display according to claim 7, further comprising:  
 40 a first interlayer insulating film (232) between the metal bridge (231) and a layer of the first transparent channel  
 electrode (2331) and the second transparent channel electrode (2332); and  
 a second interlayer insulating film (234) formed between the common transparent electrode (235) and the layer  
 45 of the first transparent channel electrode (2331) and the second transparent channel electrode (2332),  
 wherein preferably the first interlayer insulating film (232) is not provided in a region excluding the metal bridge  
 (231) intersecting the second transparent electrode channel (2332), and the touch pad electrode (2351a, 2351b,  
 2351c).
9. The organic light emitting display according to any one of claims 1 to 8, further comprising a first etching stopper  
 50 (120) and a second etching stopper film (210) formed on back surfaces of the first buffer layer (130) and the second  
 buffer layer (120), respectively,  
 wherein preferably the first etching stopper film (120) and the second etching stopper film (210) comprise polyimide  
 or photoacryl.
10. The organic light emitting display according to claim 9, further comprising a film substrate (1000) formed on a back  
 55 surface of the first etching stopper film (120),  
 wherein preferably the film substrate(1000) is a plastic insulating film.

11. The organic light emitting display according to claim 9 or 10, further comprising a cover glass (3000) formed on a back surface of the second etching stopper film (210).

5 12. The organic light emitting display according to any one of claims 1 to 11, wherein the first buffer layer (130) and the second buffer layer (220) have a laminate structure including a plurality of inorganic films.

13. A method for manufacturing an organic light emitting display comprising:

10 forming a first etching stopper film (120) and a first moisture or air prevention buffer layer (130) on a first substrate (100), forming on the first buffer layer (130) a thin film transistor array (140) including a thin film transistor in each of a plurality of pixels defined in a matrix form, an organic light emitting diode (150) connected to each thin film transistor at each pixel, and a protective layer (160) formed on the first buffer layer (130) such that the protective layer (160) covers the thin film transistor array (140) and the organic light emitting diode (150), in an active region of the first buffer layer (130), and forming a dummy pad portion on a dead region of the first buffer layer; (130)

15 forming a second etching stopper film and a second moisture or air prevention buffer layer (200) on a second substrate (300), forming a touch electrode array (230) in an active region of the second buffer layer (220), forming a touch pad portion (2350) in a region corresponding to the dummy pad portion; and applying a sealant (450) including conductive balls (455) to the touch pad portion (2350) or the dummy pad portion;

20 joining the touch electrode array (230) to the protective layer (160), wherein after the joining, the conductive balls (455) are compressed to a predetermined thickness between the touch pad portion (2350) and the dummy pad portion, wherein the conductive balls connect said touch pad portion (2350) and dummy pad portion,

25 wherein after the joining the organic light emitting diode (150) is disposed between the touch electrode array (230) and the active region of the first buffer layer (130),

30 wherein the vertical distance between the outermost surface of the touch pad portion (2350) and the outermost surface of the dummy pad portion in the touch pad portion (2350) is smaller than the vertical distance between outermost surface of a neighboring portion adjacent to the touch pad portion in the dead region and outermost surface of neighboring portion adjacent to dummy pad portion in the dead region.

14. The method according to claim 13,

wherein, preferably, after the joining, a portion of the dead region that corresponds to the neighboring portion is spaced from the sealant (450) by a predetermined distance.

35

15. The method according to claim 13 or 14, further comprising:

removing the first substrate (100) and the second substrate (300); and

attaching a film substrate (1000) to an exposed surface of the first etching stopper film (120),

40 wherein preferably the removing the first substrate (100) and the second substrate (300) is carried out by etching or laser-irradiating the first substrate (100) and the second substrate (300).

## Patentansprüche

45

1. Eine organische lichtemittierende Anzeige, aufweisend:

eine erste Pufferschicht zum Schutz vor Feuchtigkeit oder Luft (130) und eine zweite Pufferschicht zum Schutz vor Feuchtigkeit oder Luft (220), die jeweils eine Vorderseite und eine Rückseite, und einen aktiven Bereich und einen Totbereich haben, wobei die Vorderseite der ersten Pufferschicht (130) zur Vorderseite der zweiten Pufferschicht (220) zeigt;

50

ein Dünnschicht-Transistor-Array (140), das einen Dünnschicht-Transistor in jedem von einer Vielzahl von Pixeln enthält, welche in Matrixform im aktiven Bereich auf der Vorderseite der Pufferschicht (130) angeordnet sind;

55

ein Berührungselektroden-Array (230), das in dem aktiven Bereich auf der Vorderseite der zweiten Pufferschicht (220) ausgebildet ist;

eine organische Leuchtdiode (150), die mit jedem Dünnschicht-Transistor in jedem Pixel verbunden ist und sich zwischen dem Berührungselektroden-Array (230) und dem aktiven Bereich der ersten Pufferschicht (130) be-

findet;

einen Touchpad-Teilbereich (2350), der auf einem Teil des Totbereichs der zweiten Pufferschicht (220) ausgebildet ist, wobei der Touchpad-Teilbereich (2350) auf der Vorderseite der zweiten Pufferschicht (220) ausgebildet ist;

5 einen Dummyspad-Teilbereich, der dem Touchpad-Teilbereich (2350) zugewandt ist, in dem Totbereich auf der Vorderseite der ersten Pufferschicht (130); und

ein Dichtungsmittel (450) zwischen dem Touchpad-Teilbereich (2350) und dem Dummyspad-Teilbereich, das eine Vielzahl von leitenden Kugeln (455) enthält,

10 wobei die leitenden Kugeln (455) auf eine vorgegebene Dicke zwischen dem Touchpad-Teilbereich (2350) und dem Dummyspad-Teilbereich komprimiert sind, wobei die leitenden Kugeln den Touchpad-Teilbereich (2350) und den Dummyspad-Teilbereich miteinander verbinden, und

wobei die vertikale Distanz zwischen der äußersten Fläche des Touchpad-Teilbereichs (2350) und der äußersten Fläche des Dummyspad-Teilbereichs kleiner ist als die vertikale Distanz zwischen der äußersten Fläche eines benachbarten Teilbereichs, der an den Touchpad-Teilbereich im Totbereich angrenzt, und der äußersten Fläche eines benachbarten Teilbereichs, der an den Dummyspad-Teilbereich im Totbereich angrenzt.

2. Die organische lichtemittierende Anzeige gemäß Anspruch 1, wobei der Touchpad-Teilbereich (230) eine Vielzahl von Touchpad-Elektroden (2351a, 2351b, 2351c) aufweist, die in einem Abstand voneinander angeordnet sind, und

20 wobei der Dummyspad-Teilbereich eine Vielzahl von Dummy-Elektroden (1400) aufweist, korrespondierend zu den Touchpad-Elektroden (2351a, 2351b, 2351c),

wobei vorzugsweise jede Dummy-Elektrode (1400) einen Gate-Isolations-Film (141), eine Gate-Elektroden-Schicht (142), einen Zwischenisolations-Film (143) und eine Source-Metallschicht (144) aufweist, die auf die erste Pufferschicht (130) geschichtet sind.

3. Die organische lichtemittierende Anzeige gemäß Anspruch 1 oder 2, wobei vorzugsweise sich die benachbarten Teilbereiche gegenüber liegen und mindestens einer der benachbarten Teilbereiche von dem Dichtungsmittel (450) im Totbereich um eine vorgegebene Distanz beabstandet ist.

4. Die organische lichtemittierende Anzeige gemäß Anspruch 2, wobei die Touchpad-Elektrode (2351a, 2351b, 2351c) eine Schichtstruktur aufweist, aufweisend: eine Metallstruktur (231a), eine die Metallstruktur (231a) überlappende transparente Elektrodenstruktur (233a), und mindestens einen Zwischenschichtisolationsfilm (232), der zwischen der Metallstruktur (231a) und der transparenten Elektrodenstruktur (233a) angeordnet ist,

35 wobei vorzugsweise der mindestens eine Zwischenschichtisolationsfilm (232) ein organischer Film ist, wobei weiter vorzugsweise der mindestens eine Zwischenschichtisolationsfilm (232) von dem Totbereich von mindestens einem der benachbarten Teilbereiche entfernt ist.

5. Die organische lichtemittierende Anzeige gemäß Anspruch 4, wobei das Berührungselektroden-Array (230) aufweist:

40 eine Metallbrücke (231), die in derselben Schicht wie die Metallstruktur (231a) auf der zweiten Pufferschicht (220) ausgebildet ist;

eine Vielzahl von ersten transparenten Kanal-Elektroden (2331) in derselben Schicht wie die transparente Elektrodenstruktur (233a), die elektrisch

45 mit der Metallbrücke (231) verbunden sind und die Metallbrücke (231) dabei überlappen, die ersten transparenten Kanal-Elektroden (2331) in einer ersten Richtung beabstandet; und

eine in einer zweiten Richtung ausgebildete und dabei die Metallbrücke (231) überquerende zweite transparente Kanal-Elektrode (2332) in derselben Schicht wie die erste transparente Kanal-Elektrode (2331).

6. Die organische lichtemittierende Anzeige gemäß Anspruch 5, wobei die Touchpad-Elektrode (2351a, 2351b, 2351c) ferner eine gemeinsame transparente Elektrodenstruktur (235a) aufweist, die mit der transparenten Elektrodenstruktur (233a) verbunden ist und ebendiese überlappt.

7. Die organische lichtemittierende Anzeige gemäß Anspruch 6, ferner aufweisend:  
55 eine gemeinsame transparente Elektrode (235) in derselben Schicht wie die gemeinsame transparente Elektrodenstruktur (25a), derart, dass die gemeinsame transparente Elektrode (235) die erste transparente Kanal-Elektrode (2331) und die zweite transparente Kanal-Elektrode (2332) überdeckt.

8. Die organische lichtemittierende Anzeige gemäß Anspruch 7, ferner aufweisend:

einen ersten Zwischenschichtisolationfilm (232) zwischen der Metallbrücke (231) und einer Schicht der ersten transparenten Kanal-Elektrode (2331) und der zweiten transparenten Kanal-Elektrode (2332); und  
einen zweiten Zwischenschichtisolationfilm (234), der zwischen der gemeinsamen transparenten Elektrode (235) und der Schicht der ersten transparenten Kanal-Elektrode (2331) und der zweiten transparenten Kanal-elektrode (2332) ausgebildet ist,  
wobei vorzugsweise der erste Zwischenschichtisolationfilm (232) nicht in einem Bereich bereitgestellt ist, außer dort, wo die Metallbrücke (231) den zweiten transparenten Elektroden-Kanal (2332) und die Touchpad-Elektrode (2351a, 2351b, 2351c) schneidet.

9. Die organische lichtemittierende Anzeige gemäß einem der Ansprüche 1 bis 8, ferner aufweisend:

einen ersten Ätzstopper- (120) und einen zweiten Ätzstopperfilm (210), die auf der Rückseite der ersten Pufferschicht (130) bzw. der zweiten Pufferschicht (120) ausgebildet sind,  
wobei vorzugsweise der erste Ätzstopperfilm (120) und der zweite Ätzstopperfilm (210) Polyimid oder Photoacryl aufweisen.

10. Die organische lichtemittierende Anzeige gemäß Anspruch 9, ferner aufweisend:

ein Filmsubstrat (1000), das auf einer Rückseite des ersten Ätzstopperfilms (120) ausgebildet ist,  
wobei vorzugsweise das Filmsubstrat (1000) ein Kunststoffisolationfilm ist.

11. Die organische lichtemittierende Anzeige gemäß Anspruch 9 oder 10, ferner aufweisend:

ein Deckglas, das (3000) auf einer Rückseite des zweiten Ätzstopperfilms (210) ausgebildet ist.

12. Die organische lichtemittierende Anzeige gemäß einem der Ansprüche 1 bis 11, wobei die erste Pufferschicht (130) und die zweite Pufferschicht (220) eine Schichtstruktur aufweisen, die eine Vielzahl von anorganischen Filmen enthält.

13. Ein Verfahren zur Herstellung einer organischen lichtemittierenden Anzeige, aufweisend:

Bilden eines ersten Ätzstopperfilms (120) und einer ersten Pufferschicht zum Schutz vor Feuchtigkeit oder Luft (130) auf einem ersten Substrat (100), Bilden, auf der ersten Pufferschicht (130), eines Dünnschicht-Transistor-Arrays (140), das einen Dünnschicht-Transistor in jedem von einer Vielzahl von Pixeln, die in einer Matrixform angeordnet sind, enthält, einer organischen Leuchtdiode (150), die mit jedem Dünnschicht-Transistor in jedem Pixel verbunden ist, und einer Schutzschicht (160), die auf der ersten Pufferschicht (130) gebildet sind, derart, dass die Schutzschicht (160) das Dünnschicht-Transistor-Array (140) und die organische Leuchtdiode (150) in einem aktiven Bereich der ersten Pufferschicht (130) überdeckt, und Bilden eines Dummypad-Teilbereichs auf einem Totbereich der ersten Pufferschicht (130);

Bilden eines zweiten Ätzstopperfilms und einer zweiten Pufferschicht zum Schutz vor Feuchtigkeit oder Luft (200) auf einem zweiten Substrat (300), Bilden eines Berührungselektroden-Arrays (230) in einem aktiven Bereich der zweiten Pufferschicht (220), Bilden eines Touchpad-Teilbereichs (2350) in einem Bereich, der zu dem Dummypad-Teilbereich korrespondiert; und

Auftragen eines Dichtungsmittels (450), das eine Vielzahl von leitenden Kugeln (455) enthält, auf den Touchpad-Teilbereich

(2350) oder den Dummypad-Teilbereich;

Anfügen des Berührungselektroden-Arrays (230) an die Schutzschicht (160),

wobei nach dem Anfügen die leitenden Kugeln (455) auf eine vorgegebene Dicke zwischen dem Touchpad-Teilbereich (2350) und dem Dummypad-Teilbereich komprimiert sind, wobei die leitenden Kugeln besagten Touchpad-Teilbereich (2350) und Dummypad-Teilbereich verbinden;

wobei sich nach dem Anfügen die organische Leuchtdiode (150) zwischen dem Berührungselektroden-Array (230) und dem aktiven Bereich der ersten Pufferschicht (130) befindet,

wobei die vertikale Distanz zwischen der äußersten Fläche des Touchpad-Teilbereichs (2350) und der äußersten Fläche des Dummypad-Teilbereichs in dem Touchpad-Teilbereich (2350) kleiner ist als die vertikale Distanz zwischen der äußersten Fläche eines benachbarten Teilbereichs, der an den Touchpad-Teilbereich in dem Totbereich angrenzt, und der äußersten Fläche eines benachbarten Teilbereichs, der an den Dummypad-Teilbereich in dem Totbereich angrenzt.

14. Das Verfahren gemäß Anspruch 13,  
wobei vorzugsweise nach dem Anfügen ein Teilbereich des Totbereichs, der zu dem benachbarten Teilbereich korrespondiert, um eine vorgegebene Distanz von dem Dichtungsmittel (450) beabstandet ist.

5 15. Das Verfahren gemäß Anspruch 13 oder 14, ferner aufweisend:

Entfernen des ersten Substrats (100) und des zweiten Substrats (300); und  
Anbringen eines Filmsubstrats (1000) an einer freiliegenden Oberfläche des ersten Ätzstopperfilms (120),  
wobei vorzugsweise das Entfernen des ersten Substrats (100) und des zweiten Substrats (300) durch Ätzen  
10 oder Laser-Bestrahlung des ersten Substrats (100) und des zweiten Substrats (300) durchgeführt wird.

## Revendications

15 1. Affichage organique luminescent comprenant :

une première couche tampon de protection contre l'humidité ou contre l'air (130) et une deuxième couche tampon de protection contre l'humidité ou contre l'air (220), chacune comprenant une surface frontale et une surface arrière, et une région active et une région morte, la surface frontale de la première couche tampon (130) faisant face à la surface frontale de la deuxième couche tampon (220) ;

20 une matrice de transistor à film mince (140) comprenant un transistor à film mince dans chacun de la pluralité de pixels définis dans une forme matricielle au niveau de la région active sur la surface frontale de la première couche tampon (130) ;

25 une matrice d'électrode tactile (230) formée au niveau de la région active sur la surface frontale de la deuxième couche tampon (220) ;

une diode organique luminescente (150) connectée à chaque transistor à film mince au niveau de chaque pixel et disposé entre la matrice d'électrode tactile (230) et la région active de la première couche tampon (130) ;

une portion de pavé tactile (2350) formée sur une partie de la région morte de la deuxième couche tampon (220), la portion de pavé tactile (2350) étant formée sur la surface frontale de la deuxième couche tampon (220) ;

30 une portion de pavé factice qui fait face à la portion de pavé tactile (2350) au niveau de la région morte sur la surface frontale de la première couche tampon (130) ; et

un enduit (450) comprenant une pluralité de billes conductrices (455) entre la portion de pavé tactile (2350) et la portion de pavé factice,

35 les billes conductrices (455) étant comprimées jusqu'à une épaisseur prédéterminée entre la portion de pavé tactile (2350) et la portion de pavé factice, les billes conductrices connectant la portion de pavé tactile (2350) et la portion de pavé factice entre elles et

40 la distance verticale entre la surface la plus à l'extérieur de la portion de pavé tactile (2350) et la surface la plus à l'extérieur de la portion de pavé factice étant inférieure à la distance verticale entre la surface la plus à l'extérieur d'une portion voisine adjacente à la portion de pavé tactile dans la région morte et la surface la plus à l'extérieur d'une portion voisine adjacente à la portion de pavé factice dans la région morte.

2. Affichage organique luminescent selon la revendication 1,

la portion de pavé tactile (230) comprenant une pluralité d'électrodes de pavé tactile (2351a, 2351b, 2351c) espacées les unes des autres et

45 la portion de pavé factice comprenant une pluralité d'électrodes factices (1400) correspondant aux électrodes du pavé tactile (2351a, 2351b, 2351c), de préférence chaque électrode factice (1400) comprenant un film d'isolation de grille (141), une couche d'électrode de grille (142), un film d'isolation intermédiaire (143) et une couche métallique de source (144) laminée sur la première couche tampon (130).

50 3. Affichage organique luminescent selon la revendication 1 ou 2,

dans lequel, de préférence, les portions voisines se font face et au moins une des portions voisines est espacée de l'enduit (450) dans la région morte d'une distance prédéterminée.

4. Affichage organique luminescent selon la revendication 2,

55 dans lequel l'électrode de pavé tactile (2351a, 2351b, 2351c) présente une structure stratifiée comprenant: un motif métallique (231a) ; un motif d'électrode transparent (233a) se superposant avec le motif métallique (231a), et au moins un film d'isolation inter-couche (232) disposé entre le motif métallique (231a) et le motif d'électrode transparent (233a),

de préférence l'au moins un film d'isolation inter-couche (232) étant un film organique,  
de préférence l'au moins un film d'isolation inter-couche (232) étant éliminé de la région morte d'au moins une des portions voisines.

- 5 **5.** Affichage organique luminescent selon la revendication 4, dans lequel la matrice d'électrode tactile (230) comprend :
- un pont métallique (231) formé dans la même couche que le motif métallique (231a) sur la deuxième couche tampon (220) ;  
une pluralité de premières électrodes à canaux transparents (2331) connectées électriquement au pont métallique (231) tout en étant superposées avec le pont métallique (231) dans la même couche que le motif d'électrode transparent (233a), les premières électrodes à canaux transparents (2331) étant espacées dans une première direction ; et  
une deuxième électrode à canal transparent (2332) formée dans une deuxième direction tout en traversant le pont métallique (231) dans la même couche que la première électrode à canal transparent (2331).
- 10
- 15 **6.** Affichage organique luminescent selon la revendication 5, dans lequel l'électrode de pavé tactile (2351a, 2351b, 2351c) comprend en outre un motif d'électrode transparent commun (235a) qui est connecté au motif d'électrode transparent (233a) et se superpose à celui-ci.
- 20 **7.** Affichage organique luminescent selon la revendication 6, comprenant en outre une électrode transparente commune (235) dans la même couche que le motif d'électrode transparent commun (25a) de façon à ce que l'électrode transparente commune (235) recouvre la première électrode à canal transparent (2331) et la deuxième électrode à canal transparent (2332).
- 25 **8.** Affichage organique luminescent selon la revendication 7, comprenant en outre :
- un premier film d'isolation inter-couche (232) entre le pont métallique (231) et une couche de la première électrode à canal transparent (2331) et la deuxième électrode à canal transparent (2332) ;  
un deuxième film d'isolation inter-couche (234) formé entre l'électrode transparente commune (235) et la couche de la première électrode à canal transparent (2331) et la deuxième électrode à canal transparent (2332),  
de préférence le premier film d'isolation inter-couche (232) n'étant pas prévu dans une région excluant le pont métallique (231) se croisant avec la deuxième électrode à canal transparent (2332) et l'électrode de pavé tactile (2351a, 2351b, 2351c).
- 30
- 35 **9.** Affichage organique luminescent selon l'une des revendications 1 à 8, comprenant en outre un premier film d'arrêt de gravure (120) et un deuxième film d'arrêt de gravure (210) formés sur des surfaces arrière de la première couche tampon (130) et de la deuxième couche tampon (120) respectivement,  
de préférence le premier film d'arrêt de gravure (120) et le deuxième film d'arrêt de gravure (210) contiennent du polyimide ou du photoacryle.
- 40 **10.** Affichage organique luminescent selon la revendication 9, comprenant en outre un substrat de film (1000) formé sur une surface arrière du premier film d'arrêt de gravure (120),  
de préférence le substrat de film (1000) étant un film isolant en matière plastique.
- 45 **11.** Affichage organique luminescent selon la revendication 9 ou 10, comprenant en outre un verre de recouvrement (3000) formé sur une surface arrière du deuxième film d'arrêt de gravure (210).
- 12.** Affichage organique luminescent selon l'une des revendications 1 à 11, dans lequel la première couche tampon (130) et la deuxième couche tampon (220) présentent une structure laminée comprenant une pluralité de films inorganiques.
- 50 **13.** Procédé de fabrication d'un affichage organique luminescent comprenant :
- la formation d'un premier film d'arrêt de gravure (120) et d'une première couche tampon de protection contre l'humidité ou l'air (130) sur un premier substrat (100), la formation sur la première couche tampon (130) d'une matrice de transistor à film mince (140) comprenant un transistor à film mince dans chacun d'une pluralité de pixels définis dans une forme matricielle, une diode organique luminescente (150) connectée à chaque transistor à film mince au niveau de chaque pixel, et une couche protectrice (160) formée sur la première couche tampon
- 55

(130) de façon à ce que la couche protectrice (160) recouvre la matrice de transistor à film mince (140) et la diode organique luminescente (150), dans une région active de la première couche tampon (130) et la formation d'une portion de pavé factice sur une région morte de la première couche tampon (130) ;  
la formation d'un deuxième film d'arrêt de gravure et d'une deuxième couche tampon de protection contre l'humidité ou l'air (200) sur un deuxième substrat (300), la formation d'une matrice d'électrode tactile (230) dans une région active de la deuxième couche tampons (220), la formation d'une portion de pavé tactile (2350) dans une région correspondant à la portion de pavé factice ; et  
l'application d'un enduit (450) comprenant des billes conductrices (455) sur la portion de pavé tactile (2350) ou à la portion de pavé factice ;  
la jonction de la matrice d'électrode tactile (230) avec la couche protectrice (160),  
après la jonction, les billes conductrices (455) étant comprimées jusqu'à une épaisseur prédéterminée entre la portion de pavé tactile (2350) et la portion de pavé factice, les billes conductrices connectant lesdites portion de pavé tactile (2350) et portion de pavé factice,  
après la jonction, la diode organique luminescente (150) étant disposée entre la matrice d'électrode tactile (230) et la région active de la première couche tampon (130),  
la distance verticale entre la surface la plus à l'extérieur de la portion de pavé tactile (2350) et la surface la plus à l'extérieur de la portion de pavé factice dans la portion de pavé tactile (2350) étant inférieure à la distance verticale entre la surface la plus à l'extérieur d'une portion voisine adjacente à la portion de pavé tactile dans la région morte et la surface la plus à l'extérieur de la portion voisine adjacente à la portion de pavé factice dans la région morte.

**14.** Procédé selon la revendication 13, dans lequel, de préférence, après la jonction, une portion de la région morte qui correspond à la portion voisine est espacée de l'enduit (450) d'une distance prédéterminée.

**15.** Procédé selon la revendication 13 ou 14, comprenant en outre :

l'élimination du premier substrat (100) et du deuxième substrat (300) ; et  
la fixation d'un substrat de film (1000) à une surface exposée du premier film d'arrêt de gravure (120), de préférence l'élimination du premier substrat (100) et du deuxième substrat (300) étant effectuée par la gravure ou l'irradiation au laser du premier substrat (100) et du deuxième substrat (300).

# FIG. 1 RELATED ART

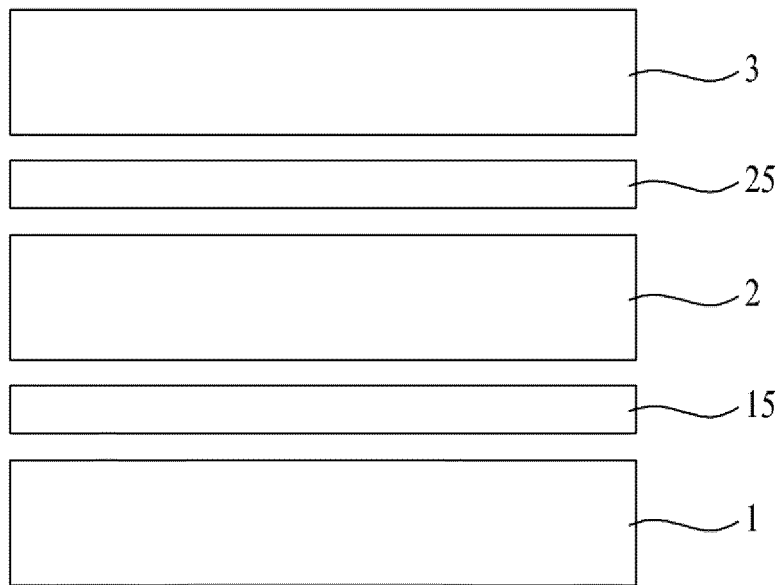

**FIG. 2**

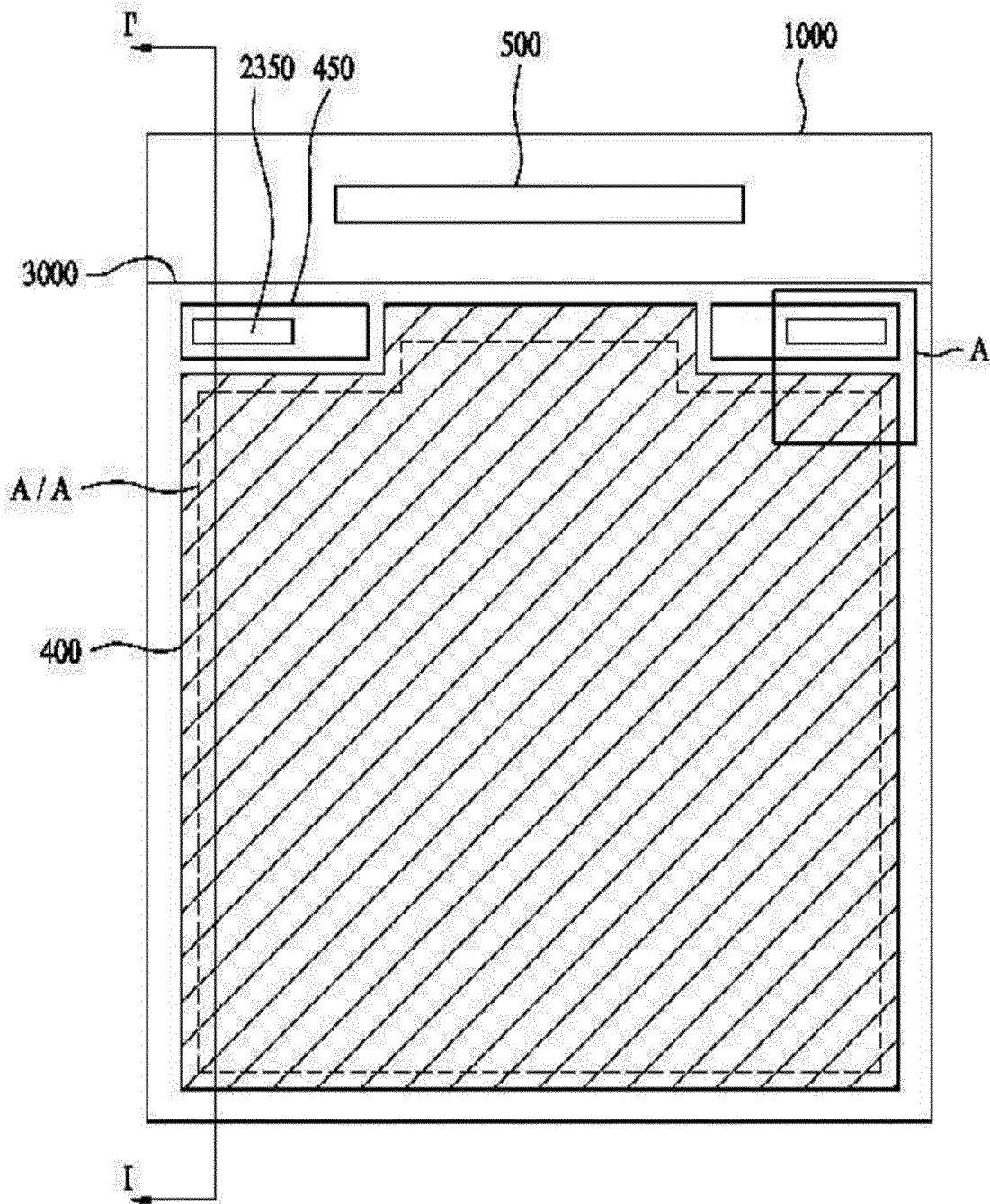
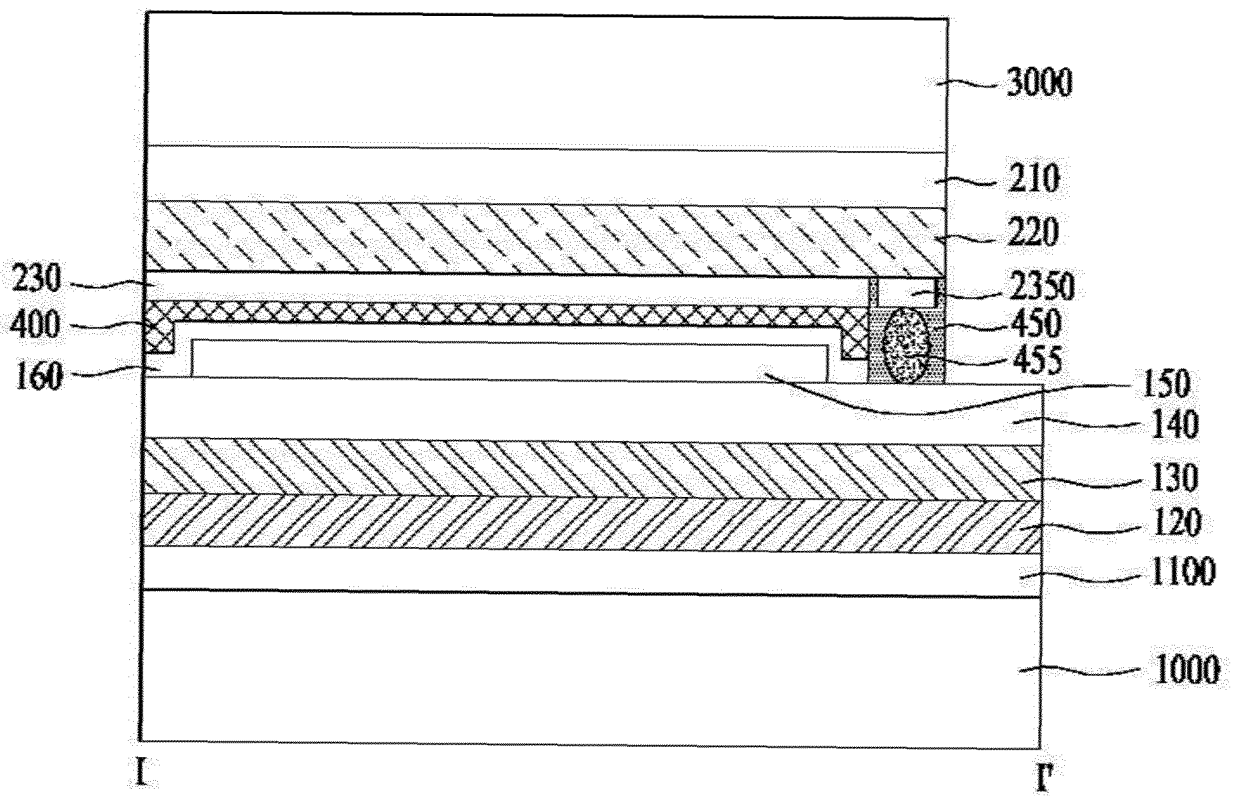
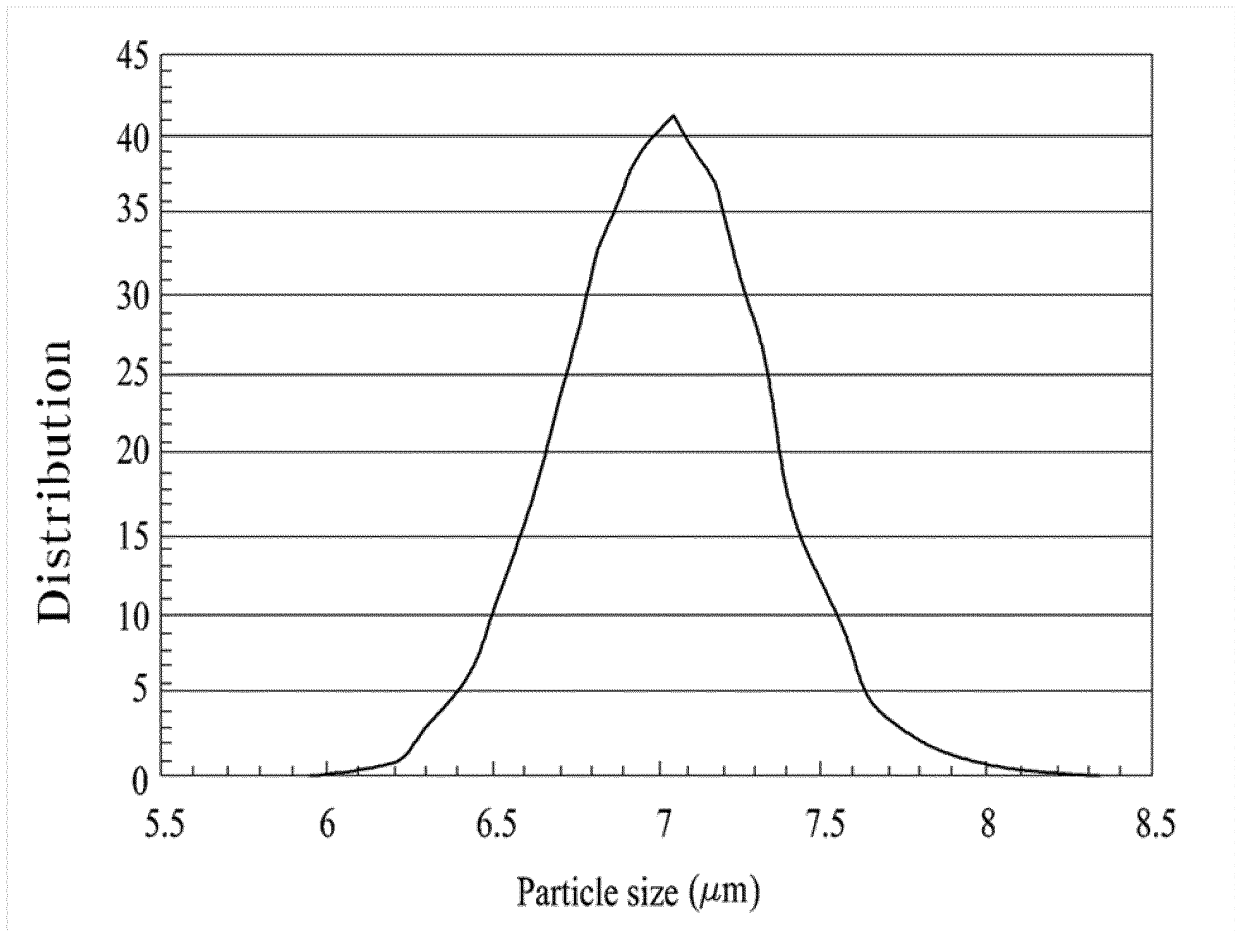

FIG. 3



**FIG. 4**



**FIG. 5**

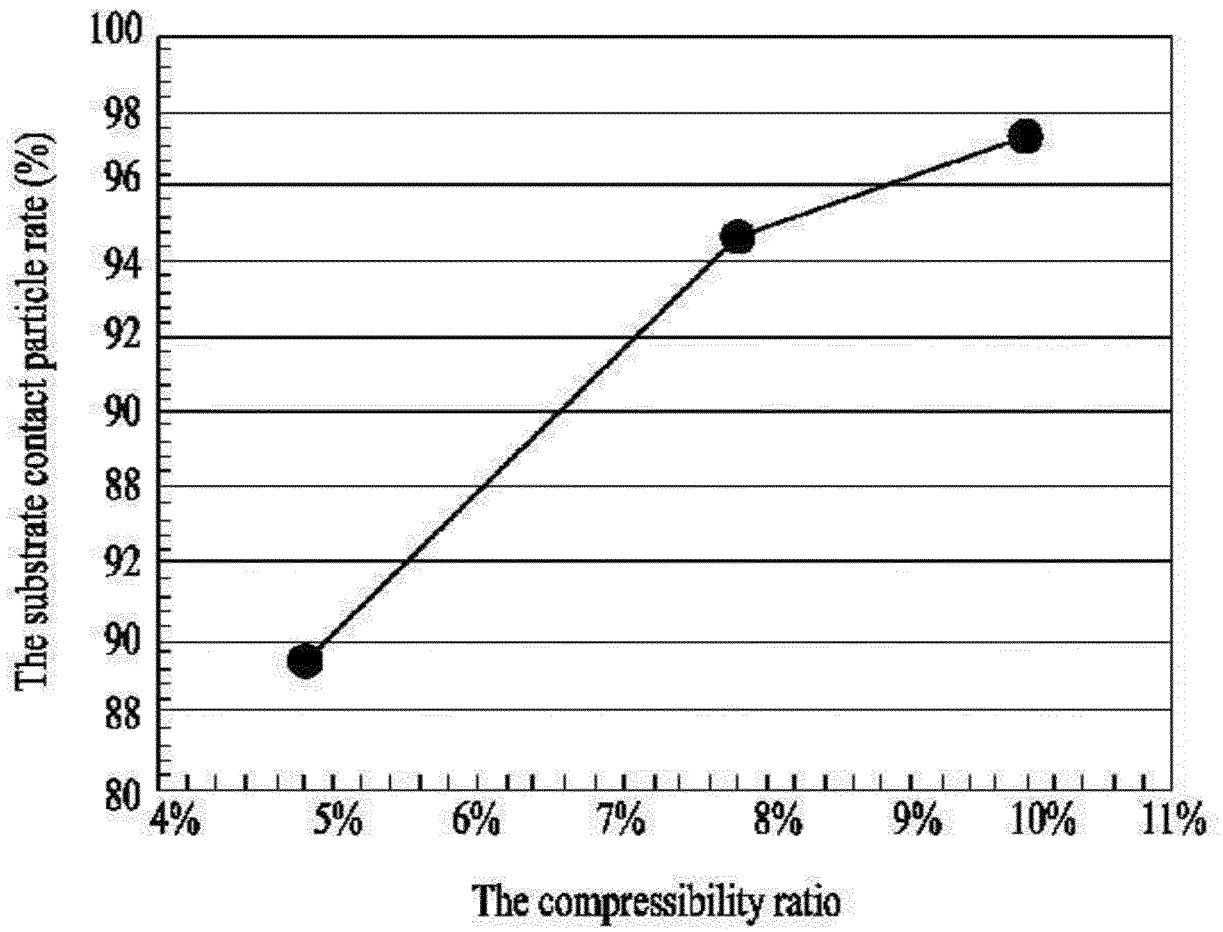

**FIG. 6**

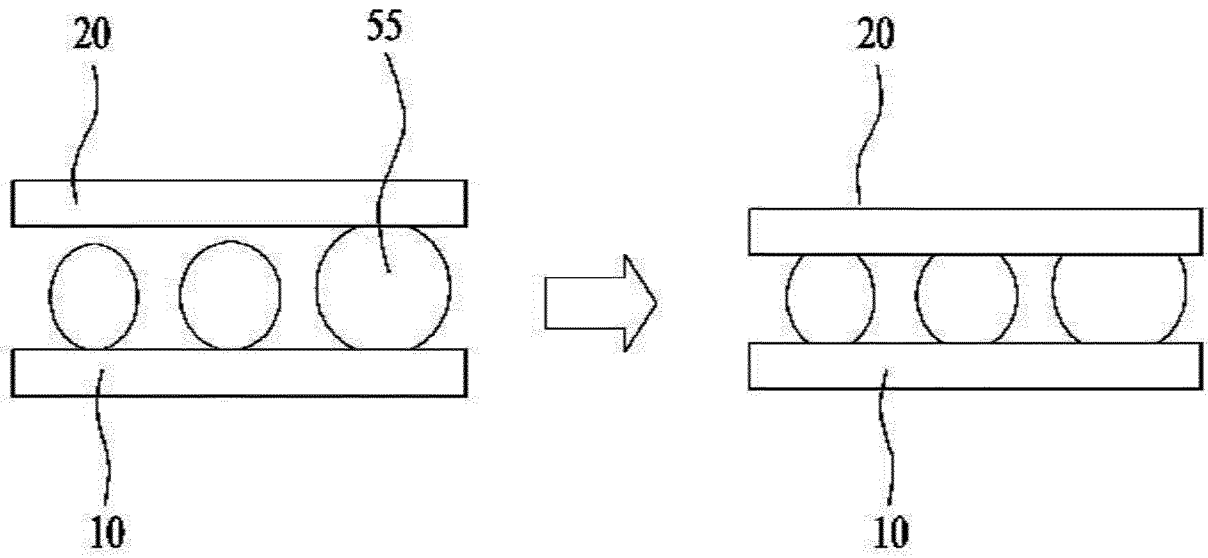

FIG. 7

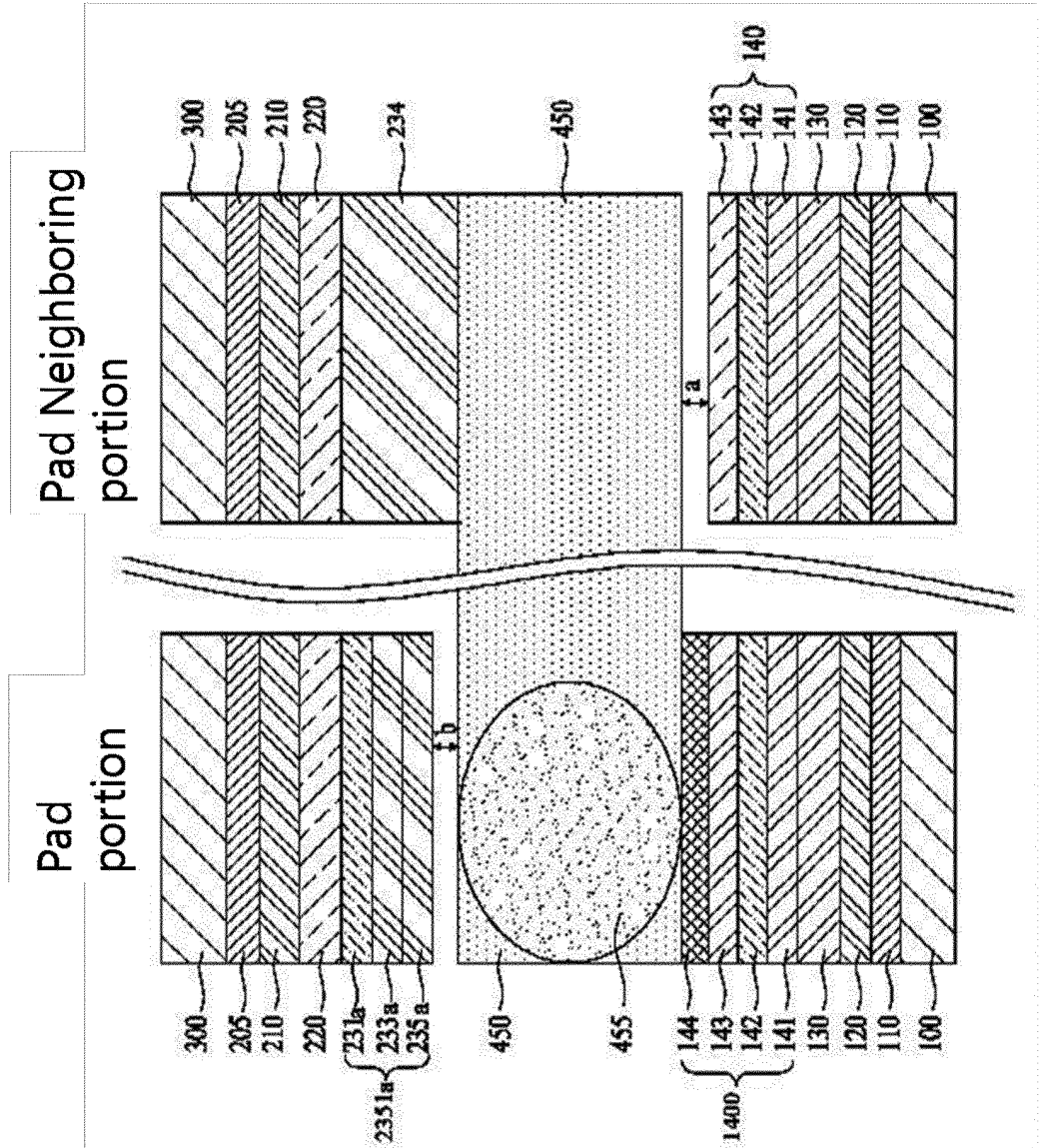

FIG. 8

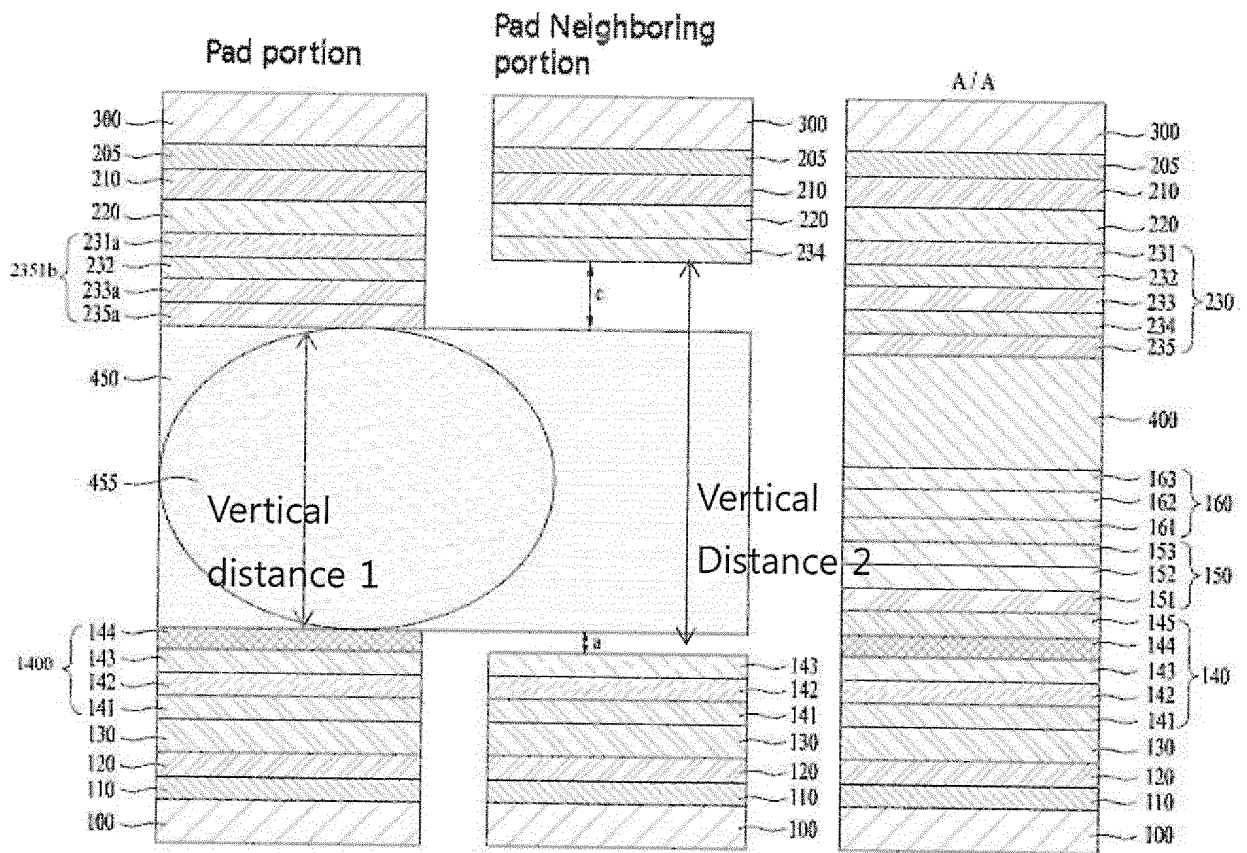

FIG. 9

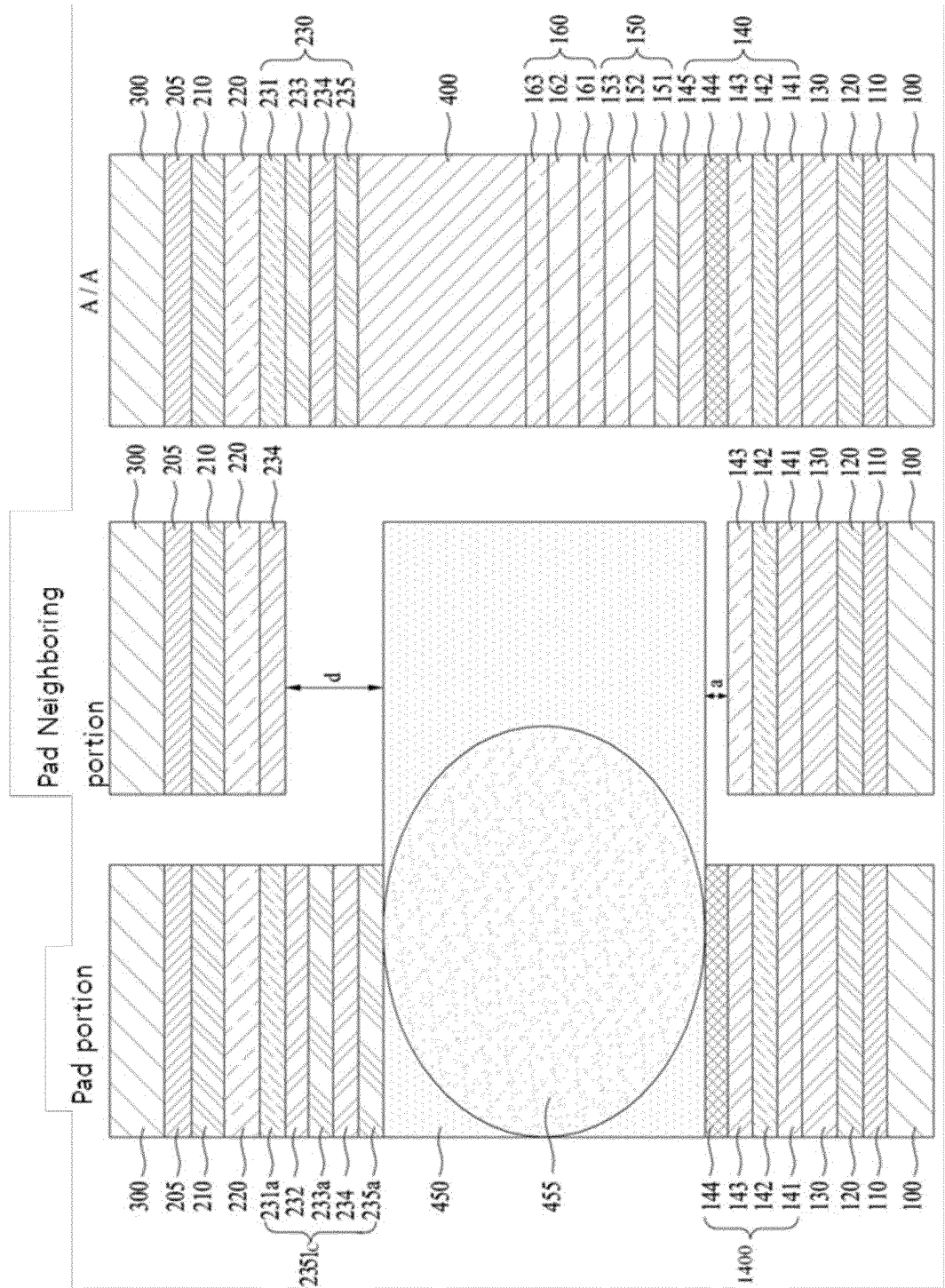

FIG. 10

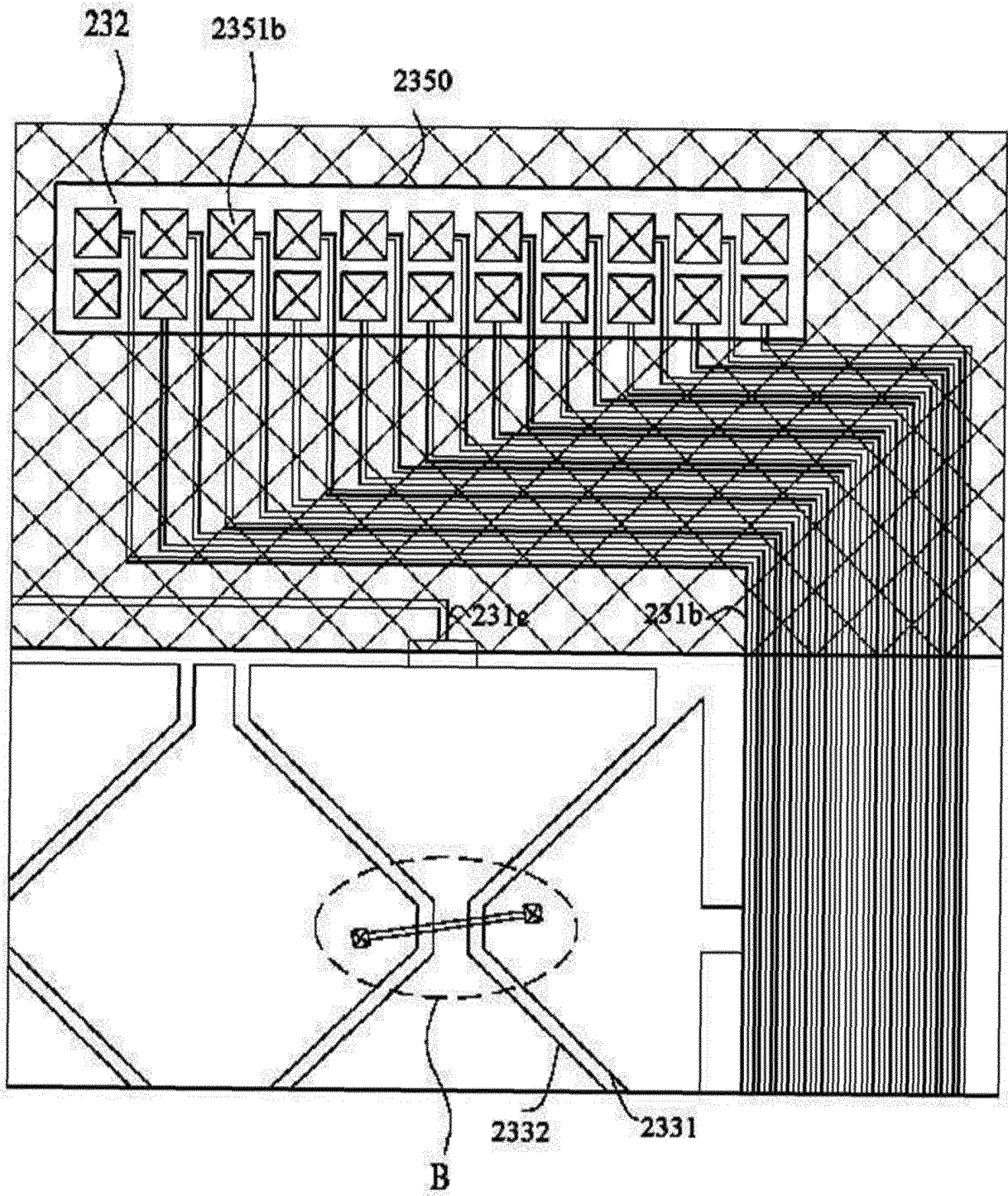

FIG. 11A

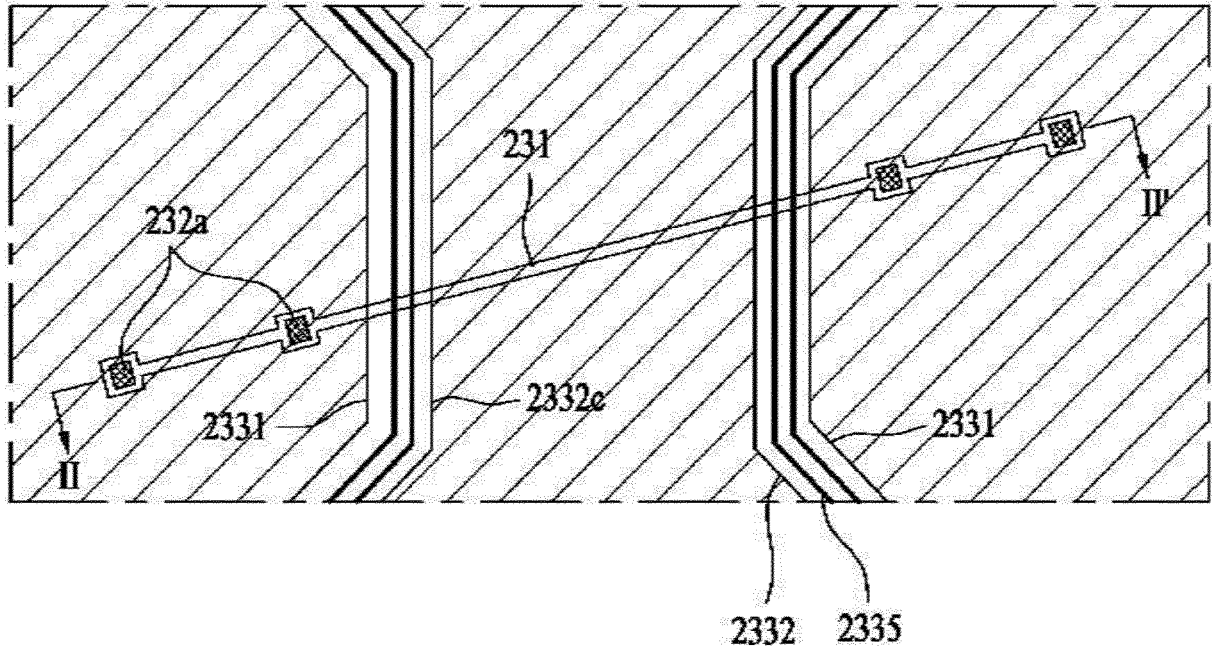

FIG. 11B

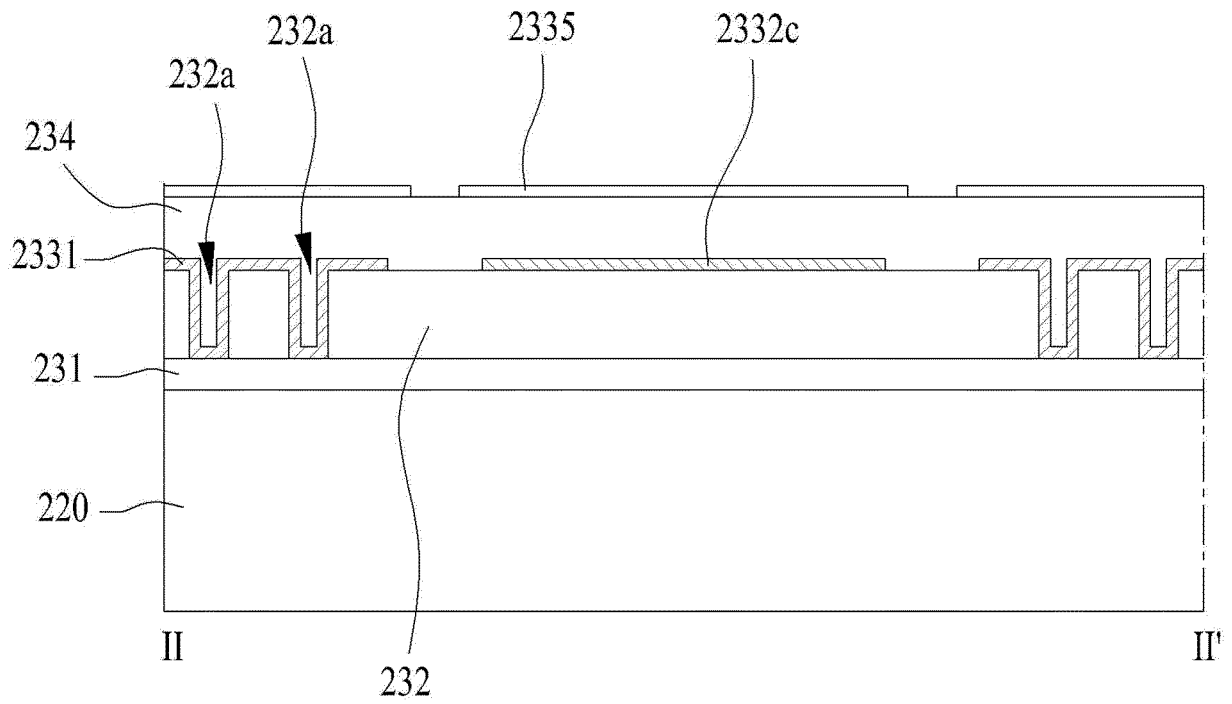

FIG. 12

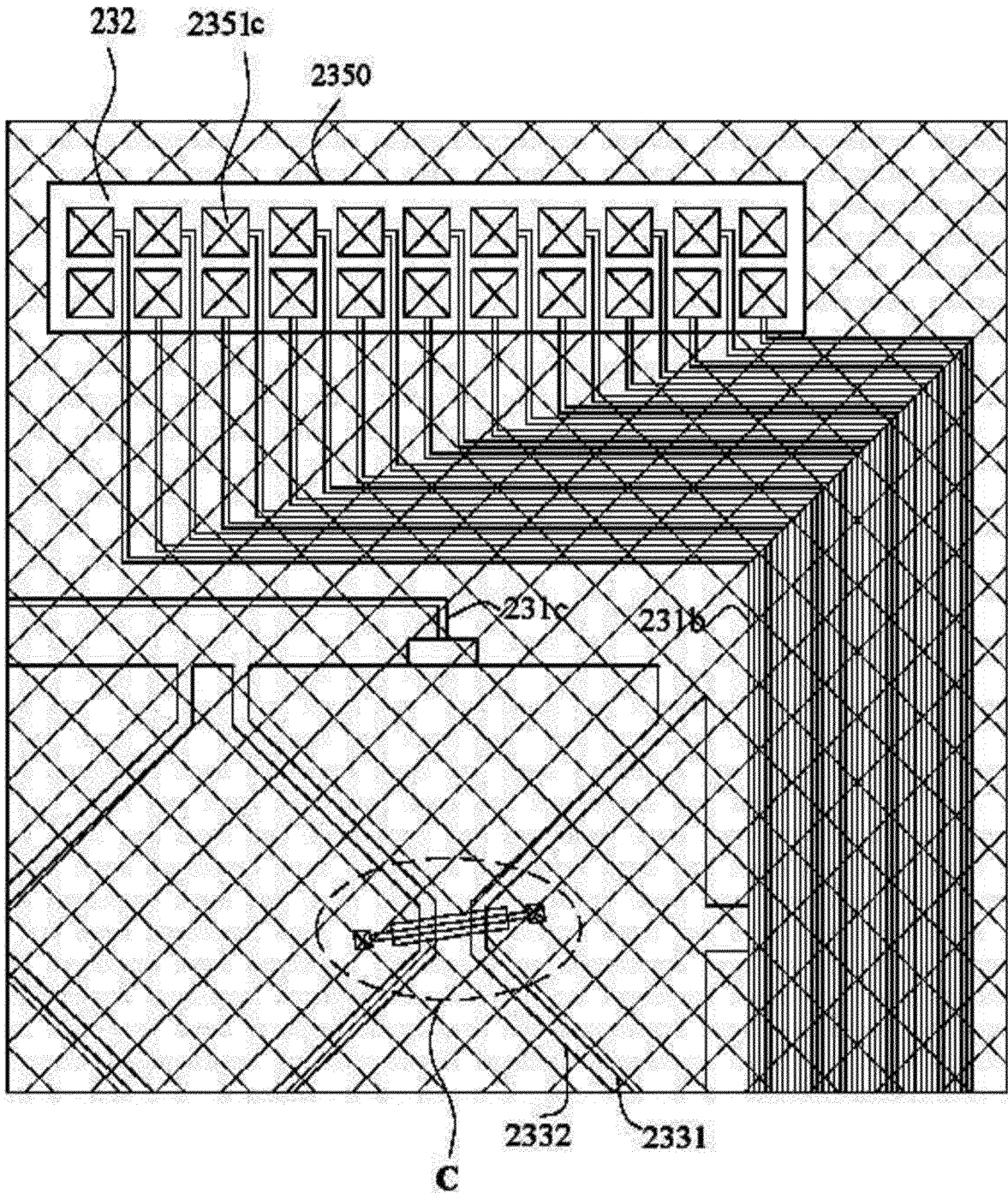

FIG. 13A

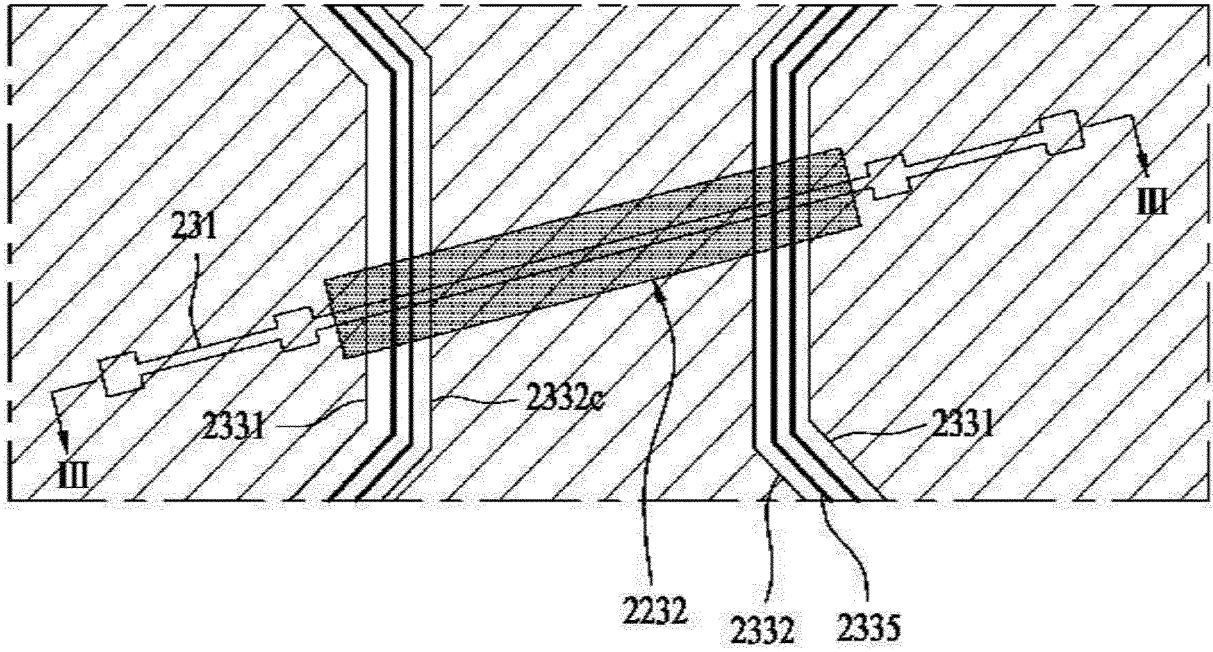
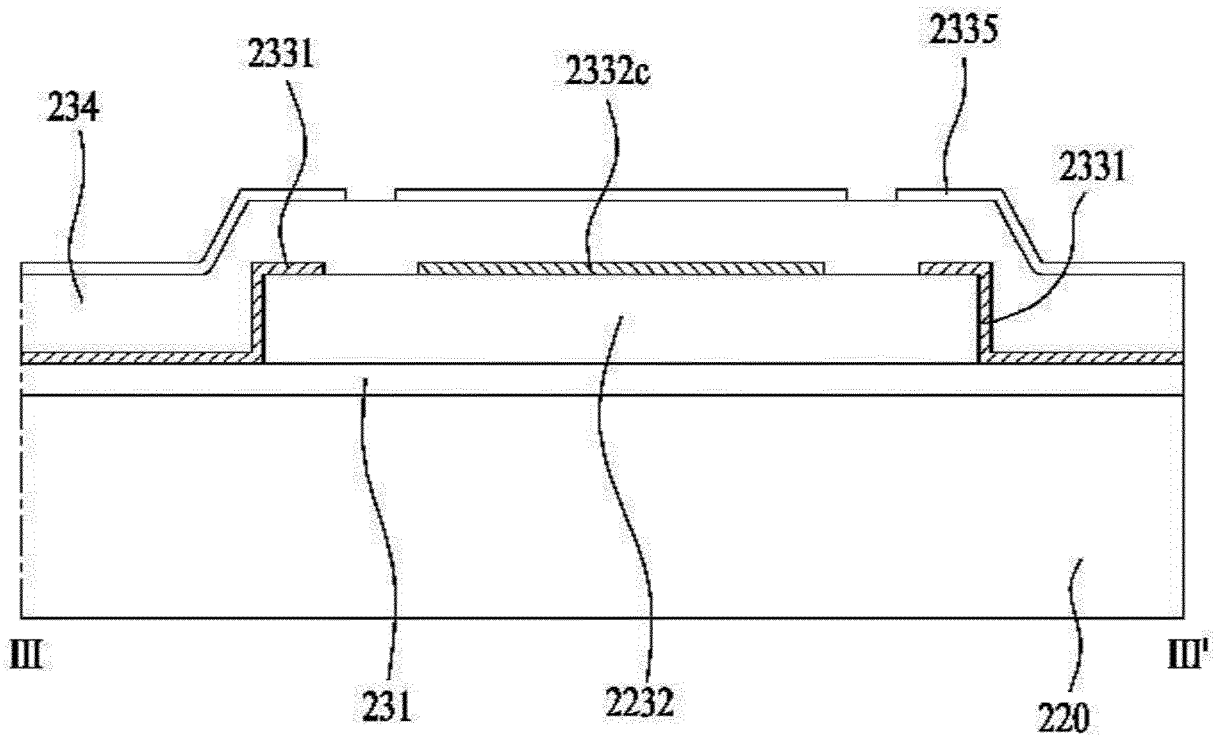

FIG. 13B



**REFERENCES CITED IN THE DESCRIPTION**

*This list of references cited by the applicant is for the reader's convenience only. It does not form part of the European patent document. Even though great care has been taken in compiling the references, errors or omissions cannot be excluded and the EPO disclaims all liability in this regard.*

**Patent documents cited in the description**

- US 2012105434 A1 [0016]
- US 2010060603 A1 [0017]
- EP 2423792 A2 [0018]

专利名称(译)	有机发光显示器及其制造方法		
公开(公告)号	<a href="#">EP2698821B1</a>	公开(公告)日	2018-08-08
申请号	EP2012199325	申请日	2012-12-24
[标]申请(专利权)人(译)	乐金显示有限公司		
申请(专利权)人(译)	LG DISPLAY CO. , LTD.		
当前申请(专利权)人(译)	LG DISPLAY CO. , LTD.		
[标]发明人	CHOI HO WON KIM JIN YEOL		
发明人	CHOI, HO-WON KIM, JIN-YEOL		
IPC分类号	H01L27/32 G06F3/041 H01L51/52		
CPC分类号	G06F3/0412 G06F3/0445 G06F3/0446 G06F3/0447 H01L27/323 H01L27/3244 H01L51/5243 H01L51/5246 H01L33/08 H01L51/50 H01L51/5203 H01L51/524 H01L51/56 H01L21/02304 H01L23/145 H01L51/442 H01L2924/13069 G06F3/044 H01L51/5237		
优先权	1020120088540 2012-08-13 KR		
其他公开文献	EP2698821A3 EP2698821A2		
外部链接	<a href="#">Espacenet</a>		

摘要(译)

公开了一种有机发光显示器，其能够实现薄膜形状和柔性，并且基于改进的结构在触摸板中显示出优异的接触性能，以及制造该有机发光显示器的方法，其中触摸的最外表面之间的距离触摸板部分中的焊盘部分和虚设焊盘部分的最外表面小于与触摸板部分相邻的相邻部分中的距离。

**FIG. 1  
RELATED ART**

