



(11) **EP 2 530 669 A1**

(12) **EUROPEAN PATENT APPLICATION**

(43) Date of publication: **05.12.2012 Bulletin 2012/49** (51) Int Cl.: **G09G 3/32<sup>(2006.01)</sup>**

(21) Application number: **12170421.7**

(22) Date of filing: **01.06.2012**

(84) Designated Contracting States:  
**AL AT BE BG CH CY CZ DE DK EE ES FI FR GB GR HR HU IE IS IT LI LT LU LV MC MK MT NL NO PL PT RO RS SE SI SK SM TR**  
Designated Extension States:  
**BA ME**

- **Long, Chunping**  
**100176 Beijing (CN)**
- **Cheng, Jun**  
**100176 Beijing (CN)**
- **Shi, Lei**  
**100176 Beijing (CN)**
- **Wang, Dongfang**  
**100176 Beijing (CN)**
- **Jiang, Chunsheng**  
**100176 Beijing (CN)**
- **Liu, Zheng**  
**100176 Beijing (CN)**

(30) Priority: **02.06.2011 CN 201110147548**

(71) Applicant: **Boe Technology Group Co. Ltd.**  
**Beijing 100015 (CN)**

- (72) Inventors:
- **Liang, Yanan**  
**100176 Beijing (CN)**
  - **Ma, Zhanjie**  
**100176 Beijing (CN)**

(74) Representative: **Brötz, Helmut et al**  
**Rieder & Partner**  
**Corneliusstraße 45**  
**42329 Wuppertal (DE)**

(54) **Driving apparatus, oled panel and method for driving oled panel**

(57) The present disclosure relates to a driving apparatus, an OLED (Organic Light-Emitting Diode) panel, and a method for driving the OLED panel. The driving apparatus can be integrated on a substrate of pixel circuits and is capable of providing fast and stable current driving. The driving apparatus includes a switching module for selecting a voltage signal according to a received

clock signal; a conversion module for converting the voltage signal into a current signal; and an output module for outputting the voltage signal or the converted current signal to drive a pixel circuit array, wherein the switching module is connected to the conversion module and the output module, and the conversion module is connected to the switching module and the output module.

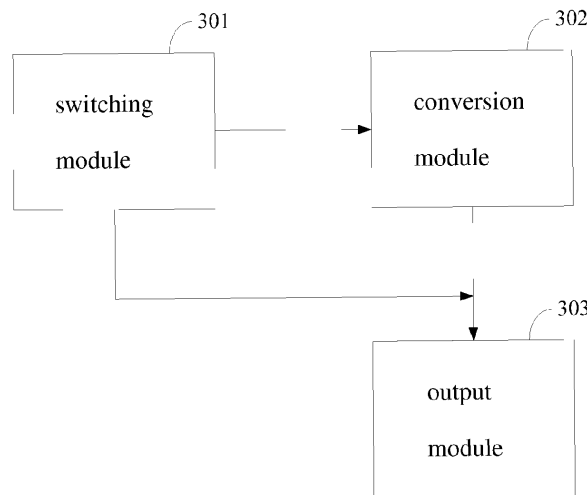

Fig.3

**EP 2 530 669 A1**

**Description**

## TECHNICAL FIELD OF THE DISCLOSURE

5 **[0001]** The present disclosure relates to a driving apparatus, an OLED(Organic Light-Emitting Diode) panel, and a method for driving OLED panel.

## BACKGROUND

10 **[0002]** A display adopting OLED (Organic Light-Emitting Diode) is a newly developing flat panel display device. Due to the advantages of the display adopting OLED, such as simple preparation process, low cost, fast response speed, easy to achieve color display and a large display screen, low power consumption, easy to match a integrated circuit driver, high luminance, wide range of operating temperature, thin and light structure, easy to achieve flexible display, and the like, so the display adopting OLED has a wide range of applications.

15 **[0003]** According to the driving manners, OLED can be divided into two different types: Passive Matrix Organic Light Emission Display (PMOLED) and Active Matrix Organic Light Emission Display (AMOLED). The Passive Matrix Organic Light Emission Display has a simple preparation process and a low cost, but has the disadvantages of crosstalk, high power consumption, and short life-span, etc., and thus does not meet the requirements of display with high resolution and large size. On the contrary, Active Matrix Organic Light Emission Display allows a pixel unit to emit light during the period of a frame by incorporating Thin Film Transistors (TFT) in the panel, and thus has the advantages of low driving current being required, low power consumption and long life-span and is capable of satisfying the requirements of display with high resolution, multiple grey levels and large size.

20 **[0004]** However, TFT has a threshold voltage, and the drift of the threshold voltage will cause non-uniformity of the luminance of OLED. Various pixel compensation circuits are proposed to solve the above problem, and can be divided, according to driving signals, into two different types: Voltage Programmed Pixel Circuit (VPPC) and Current Programmed Pixel Circuit (CPPC). CPPC is capable of compensating the effects of threshold voltage of TFT, carrier mobility and temperature. Meanwhile, the luminance of OLED can be controlled more accurately by adopting CCPC, since OLED is a current-driving device, the luminance of which is proportion to the current flowing through OLED.

25 **[0005]** The configuration of a current driving pixel unit of current mirror type in the prior art is shown in Fig. 1, and the timing sequence for controlling the pixel unit shown in Fig. 1 is illustrated in Fig.2. In Figure 1, A2 and A4 are controlled to be tuned on alternatively, and OLED is driven by A1. Such a configuration is capable of compensating the variation of the output current caused by such factors as the parameters of devices in a pixel current array and the temperature. Nevertheless, the main defect of the pixel circuit shown in Fig.1 lies in the parasitic capacitances generated by the switching transistors A2 and A3 and the overlap capacitances between signal lines, wherein the overlap capacitances causes the Current Programmed Pixel Circuit to take a long time to achieve a stable current in the condition of low grey level and low current, which in turn severely constrains the application of the pixel unit of current driving type in a display of large dimension and high resolution.

## SUMMARY

40 **[0006]** In view of the above, the present disclosure provides a driving apparatus, an OLED panel and a method for driving the OLED panel, for providing fast and stable data current and thus achieving the driving of pixel circuit of current driving type and compensation for the threshold voltage of TFT.

45 **[0007]** In an embodiment of the present disclosure, there is provided a driving apparatus including a switching module for selecting a voltage signal according to a received clock signal; a conversion module for converting the voltage signal into a current signal; and an output module for outputting the voltage signal or the converted current signal to drive a pixel circuit array, wherein an output terminal of the switching module is connected to an input terminal of the conversion module and an input terminal of the output module, and an output terminal of the conversion module is connected to an input terminal of the output module.

50 **[0008]** In an embodiment of the present disclosure, there is provided an OLED panel including substrate and a pixel circuit array formed on the substrate, as well as the driving apparatus.

55 **[0009]** In an embodiment of the present disclosure, there is provided a method for driving an OLED panel including the steps of: inputting a first level signal from a clock signal generating module to a switching module; transmitting a received data voltage signal from an output module to a pixel circuit array; inputting a second level signal from the clock signal generating module to the switching module; converting by a conversion module the received data voltage signal into a data current signal; transmitting the data current signal from the output module to the pixel circuit array to drive OLED.

**[0010]** In an embodiment of the present disclosure, there is provided a driving apparatus including a switching module for selecting a voltage signal according to a received clock signal; a conversion module for converting the voltage signal

into a current signal; and an output module for outputting the voltage signal or the converted current signal to drive a pixel circuit array, wherein the switching module is connected to the conversion module and the output module, and the conversion module is connected to the switching module and the output module. The driving apparatus according to the embodiment of the present disclosure selects the voltage signal by the switching module, and thus can firstly output the voltage signal, quickly charge/discharge parasitic capacitance on a data line by the voltage signal, and then output a current signal. So, the effect of the parasitic capacitance on the current signal is reduced and the output current can achieve a stable state quickly, which thus is helpful for the stable driving of the pixel circuit array. Meanwhile, the circuit of driving current type can effectively compensate the effects of such factors as threshold voltage of TFT, carrier mobility, temperature, and the like.

#### BRIEF DESCRIPTION OF THE DRAWINGS

**[0011]** The present disclosure will become more fully understood from the detailed description given hereinafter and the accompanying drawings which are given by way of illustration only, and thus are not limitative of the present disclosure and wherein:

**[0012]** FIG.1 is a schematic diagram showing a driving pixel unit apparatus in the prior art;

**[0013]** FIG.2 is a timing sequence diagram of the driving pixel unit apparatus shown in Fig.1;

**[0014]** FIG.3 is a main block diagram of a driving apparatus according to an embodiment of the present disclosure;

**[0015]** FIG.4 is a detail block diagram of the driving apparatus according to the embodiment of the present disclosure;

**[0016]** FIG.5A is a specific configuration diagram of the driving apparatus according to the embodiment of the present disclosure;

**[0017]** FIG.5B is a detail block diagram of the conversion module and a connection diagram of the conversion module and other modules in the embodiment of the present disclosure;

**[0018]** FIG.6A is a detail configuration diagram of the driving apparatus with a conversion module being implemented in another manner in an embodiment of the present disclosure;

**[0019]** FIG.6B is a schematic diagram of the operational amplifier in the embodiment of the present disclosure;

**[0020]** FIG.6C is a detail block diagram of the conversion module and a connection diagram of the conversion module and other modules in another embodiment of the present disclosure;

**[0021]** FIG.7 is a main flowchart of a method for driving OLED panel according to an embodiment of the present disclosure; and

**[0022]** FIG.8 is detail flowchart of the method for driving OLED panel according to an embodiment of the present disclosure.

#### DETAILED DESCRIPTION

**[0023]** In summary, a driving apparatus according to an embodiment of the present disclosure includes a switching module for selecting a voltage signal according to a received clock signal; a conversion module for converting the voltage signal into a current signal; and an output module for outputting the voltage signal or the converted current signal to drive a pixel circuit array, wherein the switching module is connected to the conversion module and the output module, and the conversion module is connected to the switching module and the output module. The driving apparatus according to the embodiment of the present disclosure can firstly output the voltage signal by selecting the voltage signal with the switching module, and quickly charge/discharge parasitic capacitance across data lines by the voltage signal, then output a current signal so as to reduce the effect of the parasitic capacitance on the current signal, so that the current signal can reach a stable state quickly, decreasing the non-uniformity of the output current and facilitating the stable driving of the pixel circuit array. Meanwhile, Current Programmed Pixel Circuit can effectively compensate the effects of such factors as threshold voltage of TFT, carrier mobility, temperature, and the like.

**[0024]** OLED panel according to an embodiment of the present disclosure includes a substrate, a pixel circuit array formed on the substrate, and a driving apparatus. An input terminal of the pixel circuit array is connected to an output terminal of the driving apparatus. That is, a data line of the pixel circuit array is connected to the output terminal of the driving apparatus.

**[0025]** Referring to Fig.3, the driving apparatus according to an embodiment of the present disclosure includes a switching module 301, a conversion module 302 and an output module 303. A first output terminal of the switching module 301 is connected to an input terminal of the conversion module 302, a second output terminal of the switching module 301 is connected to an input terminal of the output module 303, and an output terminal of the conversion module 302 is connected to an input terminal of the output module 303. All of the transistors used in the embodiment of the present disclosure may be TFT (Thin Film Field Effect Transistor).

**[0026]** Referring to Fig.4, the driving apparatus can further include a voltage generating module 304 and a clock signal generating module 305. An output terminal of the clock signal generating module 305 is connected to a first input terminal

of the switching module 301, and an output terminal of the voltage generating module 304 is connected to a second input terminal of the switching module 301.

[0027] Referring to Fig.5A, a specific configuration diagram of the driving apparatus according to the embodiment of the present disclosure is shown. The switching module 301 in the embodiment of the present disclosure may be a switching circuit. The switching module 301 is used to select and output a voltage signal according to a received clock signal. The switching module 301 can include a first switching transistor (hereinafter, referred to as T1) and a second switching transistor (hereinafter, referred to as T2). A gate of T1 is connected to a gate of T2, and is connected to the clock signal generating module 305; a source of T1 is connected to a drain of T2, and is connected to the voltage generating module 304; a drain of T1 is connected to the conversion module 302, and a source of T2 is connected to the output module 303, that is, to a data line of the pixel circuit array via the output module 303. The switching module 301 has two input terminals and two output terminals, wherein a first input terminal is the terminal at which the gate of T1 and the gate of T2 are connected, a second input terminal is the terminal at which the source of T1 and the drain of T2 are connected, a first output terminal is the terminal connected with the drain of T1, and a second output terminal is the terminal connected with the source of T2. T1 and T2 in the embodiment of the present disclosure are TFTs with opposite polarity, for example, T1 is a P type TFT and T2 is a N type TFT so that T1 and T2 are complementary, and only one control signal is required for controlling T1 and T2 to be on or off. Alternatively, T1 and T2 may also be TFTs with the same polarity, for example, both T1 and T2 are P type TFTs or N type TFTs, and two control signals are required at this time to control T1 and T2 respectively. Or, T1 and T2 may be triodes instead of TFTs, nevertheless the field effect transistor is a voltage-controlled device and the triode is a current-controlled device, and thus the switching module 301 adopting the field effect transistor has a better effect than that adopting the triode. Or, the switching module 301 may also adopts other circuits having a switching and selecting function. When T1 is a P type TFT and T2 is a N type TFT, the clock signal generating module 305 first outputs a high level signal, and thus T1 turns off and T2 turns on, so that a data voltage signal generated by the voltage generating module 304 arrives at a data line via T2 and the output module 303. The data voltage signal can charge the parasitic capacitance on the data line quickly. After that, the signal generated by the clock signal generating module 305 changes from the high level to a low level, and thus T1 turns on and T2 turns off, so the data voltage signal generated by the voltage generating module 304 does not flow directly into the output module 303, but enters into the conversion module 302 via T1.

[0028] The conversion module 302 is used to convert a received voltage signal into a current signal and output the same. The conversion module 302 includes a first transistor M1, a second transistor M2, a third transistor M3, a fourth transistor M4, a fifth transistor M5, a sixth transistor M6, a seventh transistor M7, an eighth transistor M8, a ninth transistor M9 and a tenth transistor M10. A gate of M1 is connected to the drain of T1 in the switching module 301; a drain of M1 is connected to a drain and a gate of M3 and a gate of M4; a source of M1 is connected to a source of M6, a gate and a drain of M9, and a source of M10, and is grounded; a gate and a drain of M2 is connected to a gate of M5, a drain of M4 and a gate of M10; a source of M2 is connected to a source of M9, a source of M5 and a gate of M6; a source of M3 is connected to a source of M4, a source of M7 and a source of M8 and to a first power supply VDD with a certain potential, and VDD may be an output terminal of a power supply line for supplying power in the embodiment of the present disclosure; a drain of M5 is connected to a drain and a gate of M7, and a gate of M8; a drain of M6 is connected to a drain of M8; a drain of M10 is connected to the source of T2 in the switching module 301, and both are connected to the output module 303 together, that is, both are connected to the data line of the pixel circuit array together via the output module 303. In the embodiment of the present disclosure, M1, M2, M5, M6 and M10 are all N type TFTs, and M3, M4, M7, M8 and M9 are all P type TFTs. The polarities of M1~M10 can be changed, but M1, M2, M5, M6 and M10 should be of the same polarity, and M3, M4, M7, M8 and M9 should be of the same polarity. Under such a circumstance, connections among the respective elements in the circuit can be changed respectively according to the polarities of TFTs, and those skilled in the art can easily make the corresponding variations according to the prior art and the concept of the present invention, so no more descriptions and diagrams are detailed here.

[0029] M1, M2, M3 and M4 constitute a cascode mirror current source configuration for implementing the conversion from a data voltage signal to a data current signal. The configuration may also be substituted by other configuration units having the function of voltage conversion.

[0030] Referring to Fig.5B, a detailed block diagram of the conversion module 302 in the embodiment of the present disclosure is shown. The conversion module 302 includes a data voltage input unit 30211, a threshold voltage compensating unit 30221, and a data current output unit 30231. An input terminal of the data voltage input unit 30211 is connected to the first output terminal of the switching module 301, an output terminal of the data voltage input unit 30211 is connected to an input terminal of the threshold voltage compensating unit 30221, an output terminal of the threshold voltage compensating unit 30221 is connected to an input terminal of the data current output unit 30231, and an output terminal of the data current output unit 30231 is connected to the input terminal of the output module 303.

[0031] M1, M2, M3, M4 and M9 constitute the data voltage input unit 30211 for converting the received data voltage signal into the data current signal. The data voltage input unit 30211 may also be substituted by other configurations having the function of converting a data voltage into a data current. M5, M6, M7 and M8 constitute the threshold voltage

compensating unit 30221, which implements the compensation for threshold voltage of TFT by designing TFT with different width/length ratio of channel. That is, the threshold voltage compensating unit 30221 is used to compensate the threshold voltage of the transistor. Such a configuration may also be substituted by other configuration units having the function of compensating the threshold voltage of TFT. M10 constitutes the data current output unit 30231 for outputting the converted data current signal, and is connected to the pixel circuit array via the output module 303 for inputting the data current signal to the pixel circuit array. The data voltage input unit 30211 can be also referred as a first data voltage input unit.

**[0032]** When T1 turns on and T2 turns off in the switching module 301, the data voltage signal  $V_{Data}$  enters into the conversion module 302 through the gate of M1. The gate and drain of M3 are connected together, and thus M3 operates always in the saturation region after it turns on. At the same time, the source voltage of M3 is the same as that of M4, and the gate voltage of M3 is the same as that of M4. It can be seen from Fig.5A that the current of M1 is the same as that of M3, and the current of M2 is the same as that of M4. The following equations can be obtained according to the formulae for calculating the current of TFT in the saturation region.

**[0033]**

$$I_{M1} = I_{M3} = 1/2(W/L)_{M1} C_{OX} \mu_n (V_{Data} - V_{Th})^2 \quad (1)$$

**[0034]**

$$I_{M2} = I_{M4} = 1/2(W/L)_{M2} C_{OX} \mu_n (V_{Out} - V_A - V_{Th})^2 \quad (2)$$

**[0035]**

$$I_{M1} * I_{M2} = I_{M3} * I_{M4} \quad (3)$$

**[0036]** wherein W represents the length of channel of TFT, L represents the width of channel of TFT,  $C_{ox}$  represents the capacitance of the insulating layer of TFT,  $\mu_n$  represents the carrier mobility, and  $V_{Th}$  represents the threshold voltage of TFT.  $V_A$  represents the source voltage of M5 in Fig.5A, and  $V_{out}$  represents the drain voltage of M2 in Fig.5A.

**[0037]** TFT can be designed as  $(W/L)_{M2} * (W/L)_{M4} = 4(W/L)_{M1} * (W/L)_{M3}$  so as to obtain:

**[0038]**

$$V_{Out} = 1/2 V_{Data} + V_A + 1/2 V_{Th} \quad (4)$$

**[0039]** Meanwhile, the length/width ration of channel of M5 and that of M6 can be designed to be the same, that is,  $(W/L)_{M5} = (W/L)_{M6}$ , and M7 and M8 are in a cascode connection, so the current flowing through M7 is the same as that flowing through M8, that is,  $I_{M7} = I_{M8}$ , and we can obtain:

**[0040]**

$$I_{M7} = I_{M5} = 1/2(W/L)_{M5} C_{OX} \mu_n (V_{OUT} - V_A - V_{Th})^2 \quad (5)$$

**[0041]**

$$I_{M8} = I_{M6} = 1/2(W/L)_{M6} C_{OX} \mu_n (V_A - V_{Th})^2 \quad (6)$$

[0042]

$$V_{Out}=2V_A \quad (7)$$

[0043] Then we can obtain:

[0044]

$$V_{out}=V_{Data}+V_{Th} \quad (8)$$

[0045] Then, the data current output from M10 can be:

[0046]

$$I_{Data} = 1/2(W/L)_{M10} C_{OX} \mu_n (V_{Out} - V_{Th})^2 = 1/2(W/L)_{M10} C_{OX} \mu_n V_{Data}^2 \quad (9)$$

[0047] It can be seen that the data current output from M10 is independent of the threshold voltage of TFT in the driving apparatus, that is to say, the drift of the threshold voltage of TFT will not affect the output current of the driving apparatus, and thus the compensation for the threshold voltage of TFT can be achieved.

[0048] With the conversion module 302, the conversion from the data voltage signal to the data current signal can be implemented, and thus the pixel circuit array of current driving type can be driven by a chip for providing voltage driving. As a result, the technical problem of the pixel circuit array of current driving type lacking corresponding source driving Integrated Circuit Chips can be solved, while maintaining the advantages of high stability and high accuracy of the pixel circuit array of current driving type. At the same time, the conversion module 302 is capable of compensating the threshold voltage of TFT, and thus a stable output of the data current is achieved.

[0049] Under the control of the clock signal generating module 305, the pixel circuit array is driven by a constant data voltage signal in a first stage and by a constant data current signal in a second stage. As compared with the conventional driving manner, the effects of the driving manner according to the embodiment of the present disclosure and the conventional driving manner are the same in the stage of OLED emitting light; however in the stage of driving, the driving apparatus proposed in the embodiment of the present disclosure can make the driving current achieve a stable state quickly and thus has a better effect on the driving for the pixel circuit array.

[0050] The output module 303 is used to output the voltage signal or the converted current signal to drive the pixel circuit array. More specifically, the output module 303 may be a lead wire which is connected to the input terminal of the data line. The output terminal of the data line is connected to the pixel circuit array.

[0051] The voltage generating module 304 is used to generate the data voltage signal.

[0052] The clock signal generating module 305 is used to generate a clock signal. More specifically, the clock signal generating module 305 can generate a changing clock signal. For example, the clock signal generating module 305 in the embodiment of the present disclosure first generates a first level signal, that is, a high level signal in the embodiment of the present disclosure, and then generates a second level signal, that is, a low level signal in the embodiment of the present disclosure. The signal generated by clock signal generating module 305 can change correspondingly according to the polarity of TFT in the driving apparatus.

[0053] Referring to Fig.6A, a specific configuration diagram of the driving apparatus with a conversion module 302 being implemented in another manner according to an embodiment of the present disclosure is shown.

[0054] The conversion module 302 is used to convert a received voltage signal into a current signal. The conversion module 302 includes a first amplifier A1, a second amplifier A2, a first resistor R1, a second resistor R2, a third resistor R3, a fourth resistor R4, and a fifth resistor R5. A terminal of R3 is connected to the drain of T1 in the switching module 301; another terminal of R3 is connected to a terminal of R5 and to a first input terminal of A1 (terminal D in Fig.6A); a terminal of R1 is grounded, and another terminal of R1 is connected to a terminal of R2 and to a second input terminal of A1 (that is, terminal C in Fig.6A); another terminal of R2 is connected to a terminal of R4 and to an output terminal of A1 (that is, terminal A in Fig.6A); another terminal of R4 is connected to a first input terminal of A2 (that is, terminal Vout in Fig.6A); another terminal of R5 is connected to an output terminal of A2 (that is, terminal B in Fig.6A); a second input terminal of A2 (that is, terminal E in Fig.6A) is connected to the output terminal of A2; and the terminal Vout is connected to the output module 303. A1 and A2 are cascode operational amplifiers, the schematic diagram of which is shown in Fig.6B. The cascode operational amplifier includes four TFTs (M11, M12, M13 and M14), which is similar to a differential

circuit and can suppress zero drift. In the embodiment of the present disclosure, R1, R2, R3, R4 and R5 have the same resistance.

**[0055]** Referring to Fig.6C, a detail block diagram of another conversion module 302 according to an embodiment of the present disclosure is shown. The conversion module 302 includes a data voltage input unit 30212 and a negative feedback unit 30222. A1, R1, R2, R3 and R4 constitute the data voltage input unit 30212 for converting the received data voltage signal into the data current signal. The data voltage input unit 30212 can also be substituted by other configuration units having the function of voltage converting. A2 and R5 constitute the negative feedback unit 30222 for compensating the threshold voltage of transistor. With the negative feedback circuit, the constancy of gain can be effectively increased, the non-linear distortion can be effectively reduced, the noise in the feedback loop can be effectively suppressed, and the frequency band can be effectively extended. The negative feedback unit 30222 can also be substituted by other configuration units having the effect of feedback. An input terminal of the data voltage input unit 30212 is connected to the first output terminal of the switching module 301, an output terminal of the data voltage input unit 30212 is connected to an input terminal of the negative feedback unit 30222 and the input terminal of the output module 303, and an output terminal of the negative feedback unit 30222 is connected to an input terminal of the data voltage input unit 30212. The data voltage input unit 30212 can also be referred to as a second data voltage input unit.

**[0056]** When T1 turns on and T2 turns off in the switching module 301, the data voltage signal enters the conversion module 302 via R3. The data voltage signal  $V_{Data}$  generated by the voltage generating module 304 is applied to the first input terminal of A1 via R3. According to the principle of the operational amplifier, the voltage at the terminal C and the voltage at the terminal D in Fig.6A satisfy the following equation:

**[0057]**

$$V_C = V_D \quad (10)$$

**[0058]** For the same reasons,

**[0059]**

$$V_E = V_B = V_{OUT} \quad (11)$$

**[0060]** According to the Law of Current Conservation,

**[0061]**

$$(V_{DATA} - V_D) / R_3 = (V_D - V_B) / R_5 \quad (12)$$

**[0062]**

$$(V_A - V_{OUT}) / R_4 = (V_C - V_A) / R_2 = (0 - V_C) / R_1 \quad (13)$$

**[0063]** Since  $R_1 = R_2 = R_3 = R_4 = R_5 = R$ , so we can obtain:

**[0064]**

$$V_A = 2V_C = 2V_D \quad (14)$$

**[0065]**

$$V_{DATA} + V_{OUT} = 2V_D \quad (15)$$

[0066] Then, we can obtain:

[0067]

$$I_{\text{Data}}=(V_{\text{A}}-V_{\text{OUT}})/R=V_{\text{DATA}}/R \quad (16)$$

[0068] Consequently, the conversion from the data voltage signal to the data current signal can be implemented. Also it can be seen from the equation (16) that the output data current signal is independent of the threshold voltage of TFT, and thus the compensation for the threshold voltage of TFT can be achieved.

[0069] A method for driving a pixel circuit array will be described below by means of a specific flow.

[0070] Referring to Fig.7, the main flow of the method for driving OLED panel according to the embodiment of the present disclosure is as follows:

[0071] At step 701, the clock signal generating module 305 inputs a first level signal to the switching module 301. The first level signal is a high level signal in the embodiment of the present disclosure.

[0072] At step 702, the output module 303 transmits a received data voltage signal to a pixel circuit array. In combination with Fig.6, T1 turns off and T2 turns on in the switching module 301, so the switching module 301 transmits the received data voltage signal to the output module 303, and the output module 303 then transmits the received data voltage signal to the pixel circuit array.

[0073] At step 703, the clock signal generating module 305 inputs a second level signal to the switching module 301. The second level signal is a low level signal in the embodiment of the present disclosure.

[0074] At step 704, the conversion module 302 converts the received data voltage signal into a data current signal. Combining Fig.6, T2 turns off and T1 turns on in the switching module 301, so the switching module 301 transmits the received data voltage signal to the conversion module 302, and the conversion module 302 then converts the received data voltage signal into the data current signal.

[0075] At step 705, the output module 303 transmits the data current signal to the pixel circuit array for driving OLED. After the conversion module 302 converts the received data voltage signal into the data current signal, the conversion module 302 transmits the data current signal obtained to the output module 303, and then the output module 303 transmits the data current signal to the pixel circuit array for driving OLED.

[0076] Referring Fig.8, the detailed flow of the method for driving OLED panel according to the embodiment of the present disclosure is as follows:

[0077] At step 801, the clock signal generating module 305 inputs a high level signal to the switching module 301. The embodiment of the present disclosure will be described in detail in conjunction with Fig.6.

[0078] At step 802, T2 in the switching module 301 transmits a received data voltage signal to the output module 303, at this time, T1 in the switching module 301 turns off.

[0079] At step 803, the output module 303 transmits the received data voltage signal to the pixel circuit array.

[0080] At step 804, the input signal from the clock signal generating module 305 changes from a high level to a low level.

[0081] At step 805, T1 in the switching module 301 transmits the received data voltage signal to the conversion module 302, at this time, T2 in the switching module 301 turns off.

[0082] At step 806, the conversion module 302 converts the received data voltage signal into a data current signal.

[0083] At step 807, the conversion module 302 transmits the data current signal obtained by the conversion to the output module 303.

[0084] At step 808, the output module 303 transmits the data current signal to the pixel circuit array.

[0085] The driving apparatus according to the embodiment of the present disclosure includes a switching module 301 for selecting a voltage signal according to a received clock signal; a conversion module 302 for converting the voltage signal into a current signal; and an output module 303 for outputting the voltage signal or the converted current signal to drive a pixel circuit array, wherein the switching module 301 is connected to the conversion module 302 and the output module 303, and the conversion module 302 is connected to the switching module 301 and the output module 303. The driving apparatus according to the embodiment of the present disclosure selects the voltage signal by the switching module 301, and thus can firstly output the voltage signal, quickly charge/discharge parasitic capacitance across data lines by the voltage signal; and then output a current signal. Consequently, the effect of the parasitic capacitance on the current signal is reduced, so that the output current can achieve a stable state quickly, which thus is helpful for the stable driving of the pixel circuit array. Meanwhile, the pixel circuit of current driving type can effectively compensate the effects of such factors as threshold voltage of TFT, carrier mobility, temperature, and the like, and thus the stability of the circuit can be increased.

[0086] The benefits of the embodiments of the present disclosure lie in that, by controlling the switching module 301, a data voltage signal can firstly be output to quickly charge/discharge the parasitic capacitance on a data line, so that the electrical potential on the data line can be adjusted to close to a predetermined value in a short time while reducing

the effect of the parasitic capacitance on the current signal. After that, the data voltage signal enters into the conversion module 302 under the control of the switching module 301 and is then converted to a data current signal corresponding to the data voltage signal, so as to directly drive a pixel circuit array by the data current signal, which expedites the driving process of the pixel circuit array of current driving type. As a result, the embodiment of the present disclosure may have the advantages of high accuracy and good stability. The data voltage signal in the embodiment of the present disclosure can be supplied directly by the existing data voltage generating IC (Integrated Circuit) for TFT-LCD (Thin Film Transistor-Liquid Crystal Display), so that the problem of the existing pixel circuit array of current driving type lacking a dedicated driving IC can be solved.

**[0087]** The above descriptions are only for illustrating the preferred embodiments of the present disclosure, and in no way limit the scope of the present disclosure. The embodiments of the disclosure being thus described, it will be obvious that the same may be varied in many ways. Such variations are not to be regarded as a departure from the spirit and scope of the disclosure, and all such modifications as would be obvious to those skilled in the art are intended to be included within the scope of the following claims.

## Claims

1. A driving apparatus including:

a switching module for selecting and outputting a voltage signal according to a received clock signal; a conversion module for converting the voltage signal into a current signal and outputting the current signal; and an output module for outputting the voltage signal or the converted current signal to drive a pixel circuit array, wherein a first output terminal of the switching module is connected to an input terminal of the conversion module, a second output terminal of the switching module is connected to an input terminal of the output module, and an output terminal of the conversion module is connected to an input terminal of the output module.

2. The driving apparatus of claim 1, further includes a clock signal generating module and a voltage generating module, wherein the clock signal generating module has an output terminal connected to a first input terminal of the switching module and is used for generating the clock signal; and the voltage generating module has an output terminal connected to a second input terminal of the switching module and is used for generating a data voltage signal.

3. The driving apparatus of claim 2, wherein the switching module includes a first switching transistor and a second switching transistor, wherein a gate of the first switching transistor is connected to a gate of the second switching transistor and the output terminal of the clock signal generating module; a source of the first switching transistor is connected to a drain of the second switching transistor and the output terminal of the voltage generating module; a drain of the first switching transistor is connected to the input terminal of the conversion module; and a source of the second switching transistor is connected to the input terminal of the output module.

4. The driving apparatus of claim 3, wherein the first switching transistor and the second switching transistor are of opposite polarities.

5. The driving apparatus of one of claims 3-4, wherein the conversion module includes a first data voltage input unit for converting the data voltage signal into the data current signal, a threshold voltage compensating unit for compensating the threshold voltage of transistor, and a first data current output unit for outputting the data current signal converted, wherein an input terminal of the first data voltage input unit is connected to the first output terminal of the switching module, an output terminal of the first data voltage input unit is connected to an input terminal of the threshold voltage compensating unit, an output terminal of the threshold voltage compensating unit is connected to an input terminal of the first data current output unit, and an output terminal of the first data current output unit is connected to the input terminal of the output module.

6. The driving apparatus of claim 5, wherein the first data voltage input unit includes a first transistor, a second transistor, a third transistor, a fourth transistor, and a ninth transistor; the threshold voltage compensating unit includes a fifth transistor, a sixth transistor, a seventh transistor, and a

eighth transistor; and

the first data current output unit includes a tenth transistor,

wherein a gate of the first transistor is connected to the drain of the first switching transistor; a drain of the first transistor is connected to a drain and a gate of the third transistor and a gate of the fourth transistor; a source of the first transistor is connected to a source of the sixth transistor, a gate and a drain of the ninth transistor, and a source of the tenth transistor, and is grounded; a gate and a drain of the second transistor are connected to a gate of the fifth transistor, a drain of the fourth transistor and a gate of the tenth transistor; a source of the second transistor is connected to a source of the ninth transistor, a source of the fifth transistor and a gate of the sixth transistor; a source of the third transistor is connected to a source of the fourth transistor, a source of the seventh transistor and a source of the eighth transistor and a first power supply terminal VDD; a drain of the fifth transistor is connected to a drain and a gate of the seventh transistor, and a gate of the eighth transistor; a drain of the sixth transistor is connected to a drain of the eighth transistor; and a drain of the tenth transistor is connected to the source of the second switching transistor and the output module.

7. The driving apparatus of claim 6, wherein the first transistor, the second transistor, the fifth transistor, the sixth transistor and the tenth transistor are of the same polarity, and the third transistor, the fourth transistor, the seventh transistor, the eighth transistor and the ninth transistor are of the same polarity.

8. The driving apparatus of one of claims 3-4, wherein the conversion module includes a second data voltage input unit for converting the data voltage signal into the data current signal, and a negative feedback unit for compensating the threshold voltage of transistor, wherein an input terminal of the second data voltage input unit is connected to the first output terminal of the switching module, an output terminal of the second data voltage input unit is connected to an input terminal of the negative feedback unit and the input terminal of the output module, and an output terminal of the negative feedback unit is connected to the input terminal of the second data voltage input unit.

9. The driving apparatus of claim 8, wherein the second data voltage input unit includes a first amplifier, a first resistor, a second resistor, a third resistor and a fourth resistor; the negative feedback unit includes a second amplifier and a fifth resistor, wherein a terminal of the third resistor is connected to the drain of the first switching transistor; another terminal of the third resistor is connected to a terminal of the fifth resistor and a first input terminal of the first amplifier; a terminal of the first resistor is grounded, and another terminal of the first resistor is connected to a terminal of the second resistor and a second input terminal of the first amplifier; another terminal of the second resistor is connected to a terminal of the fourth resistor and an output terminal of the first amplifier; another terminal of the fourth resistor is connected to a first input terminal of the second amplifier; another terminal of the fifth resistor is connected to an output terminal of the second amplifier; a second input terminal of the second amplifier is connected to the output terminal of the second amplifier; and the first input terminal of the second amplifier is connected to the output module.

10. The driving apparatus of claim 1, wherein the output module is a lead wire, the output terminal of which is connected to the input terminal of the data line in the pixel circuit array.

11. The driving apparatus of claim 6 or 7, wherein the first switching transistor and the second switching transistor are Thin Film Field Effect Transistors, and the first transistor, the second transistor, the third transistor, the fourth transistor, the fifth transistor, the sixth transistor, the seventh transistor, the eighth transistor, the ninth transistor and the tenth transistor are Thin Film Transistors.

12. An OLED panel including a substrate, a pixel circuit array formed on the substrate, and the driving apparatus of one of claims 1-11.

13. A method for driving OLED panel, including the steps of:

inputting a first level signal from a clock signal generating module to a switching module;  
transmitting a received data voltage signal from an output module to a pixel circuit array;  
inputting a second level signal from the clock signal generating module to the switching module;  
converting by a conversion module the received data voltage signal into a data current signal; and  
transmitting the data current signal from the output module to the pixel circuit array to drive OLED.

14. The method of claim 13, wherein

after inputting the first level signal from the clock signal generating module, the method further includes the step of transmitting the received data voltage signal by the switching module to the output module; and  
after inputting the second level signal from the clock signal generating module to the switching module, the method further includes the step of transmitting the received data voltage signal by the switching module to the conversion  
5 module.

15. The method of claim 14, wherein the first level signal is a high level signal, and the second level signal is a low level  
10 signal.

10

15

20

25

30

35

40

45

50

55

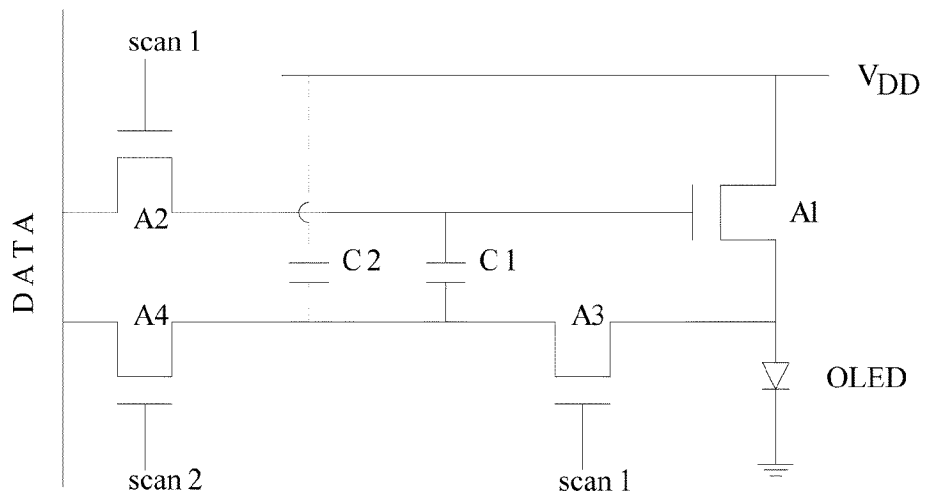

Fig.1

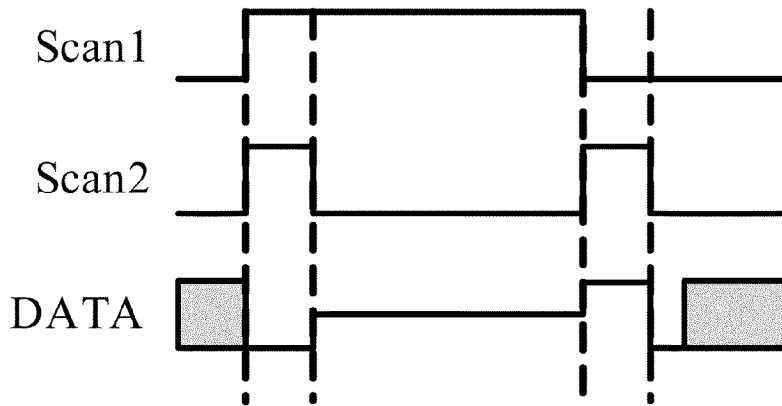

Fig.2

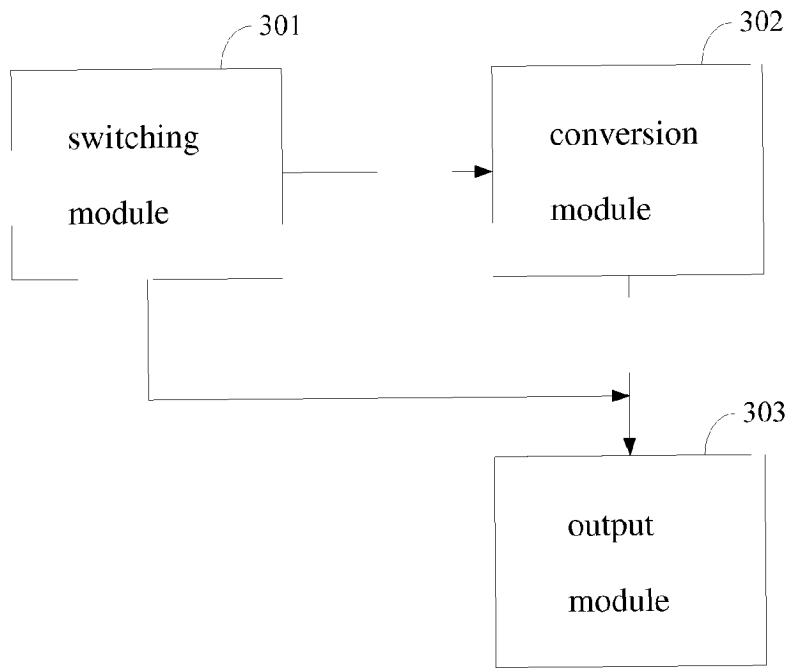

Fig.3

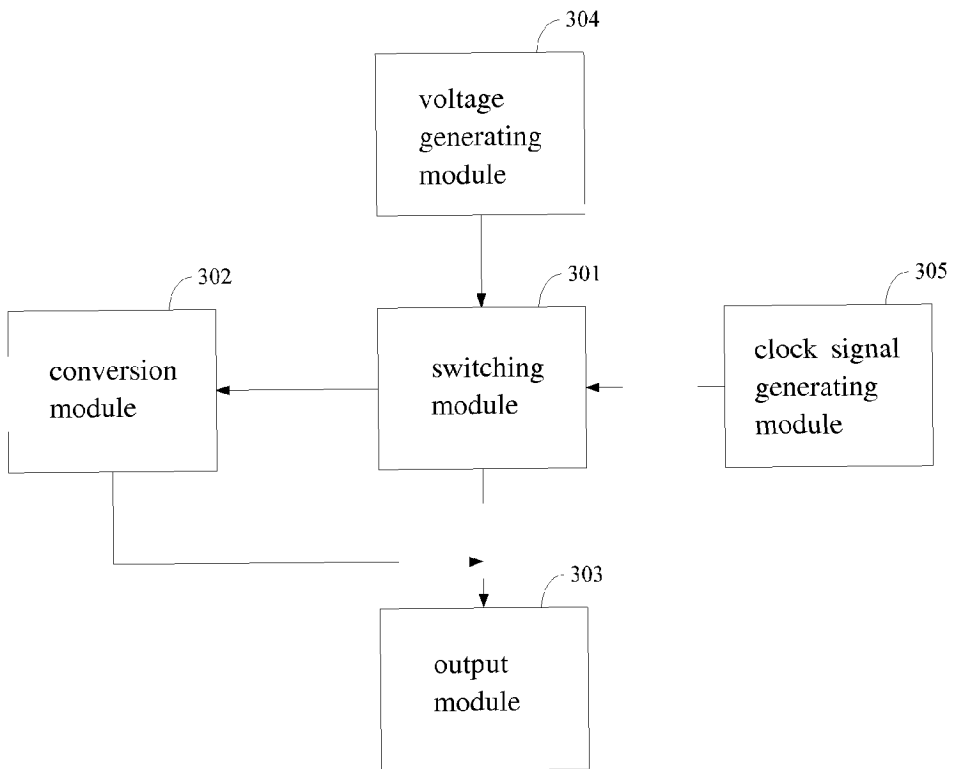

Fig.4



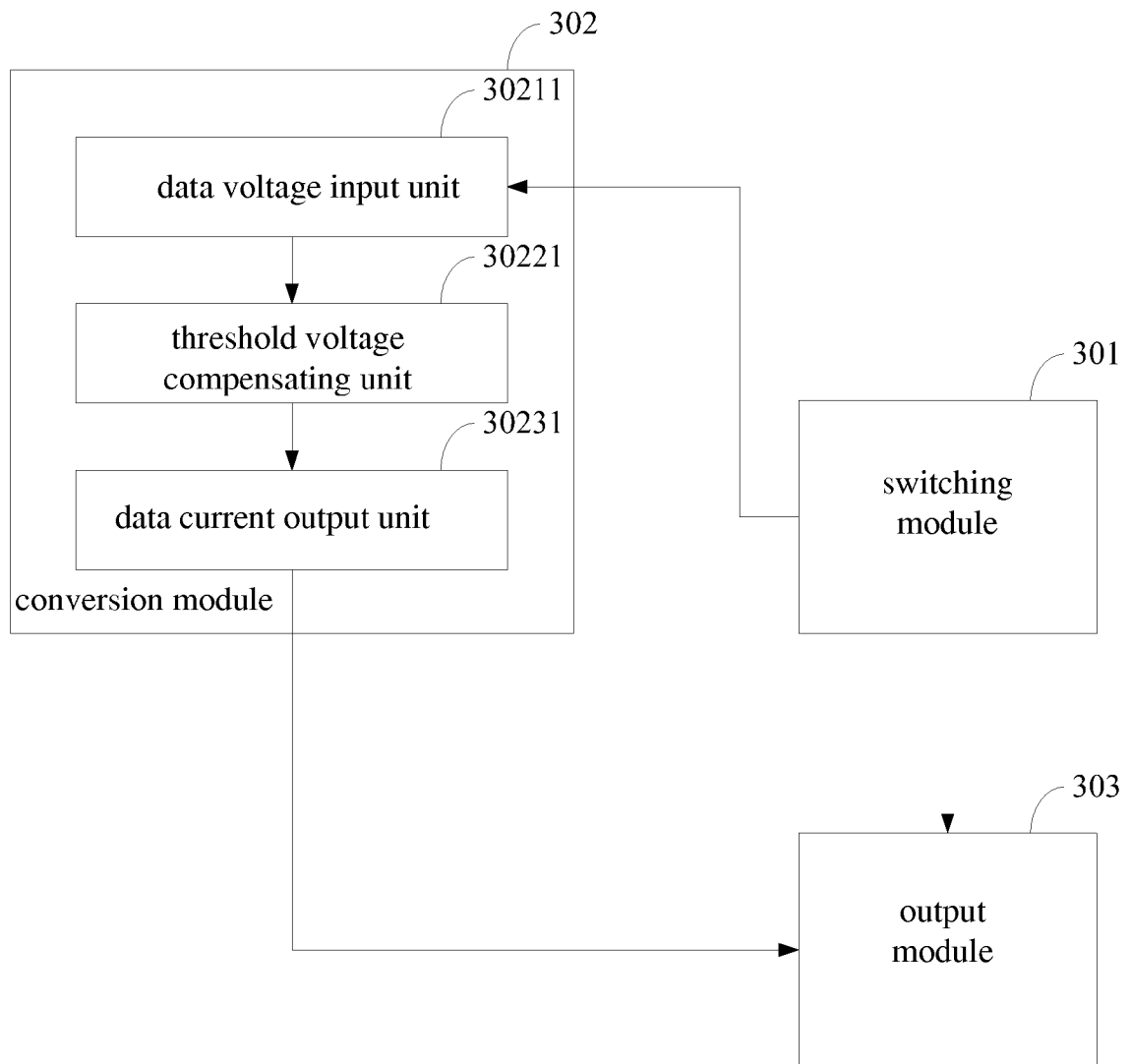

Fig.5B

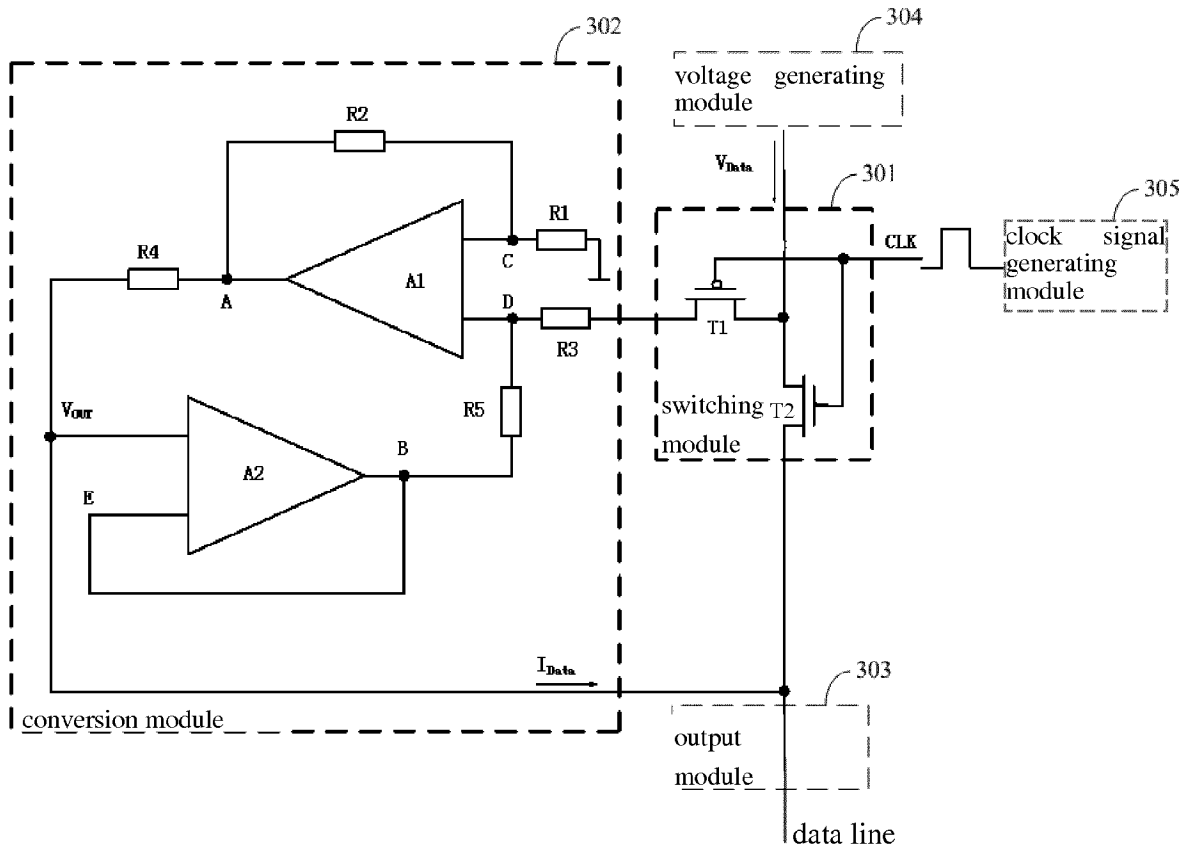

Fig.6A

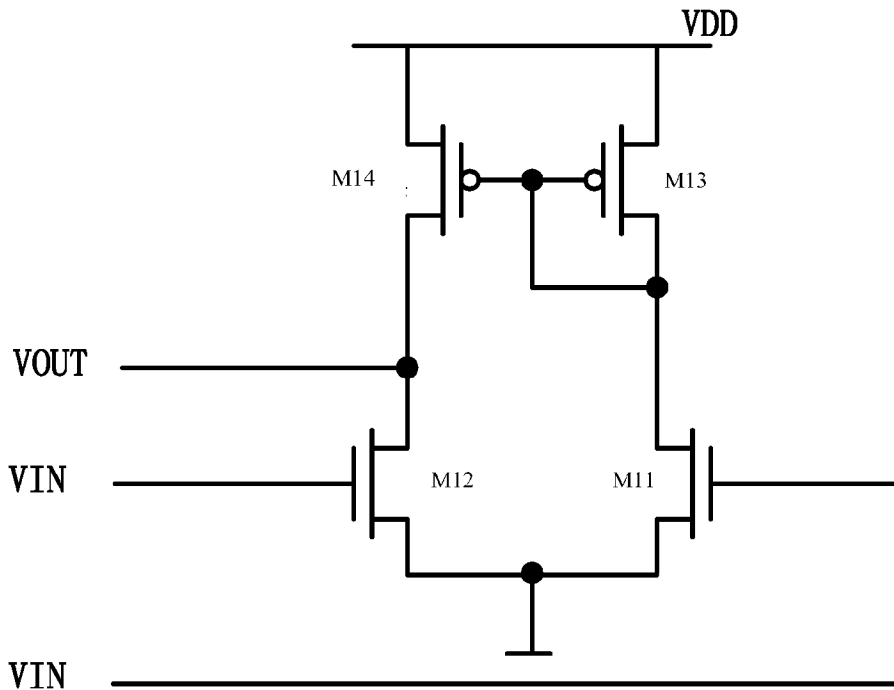

Fig.6B

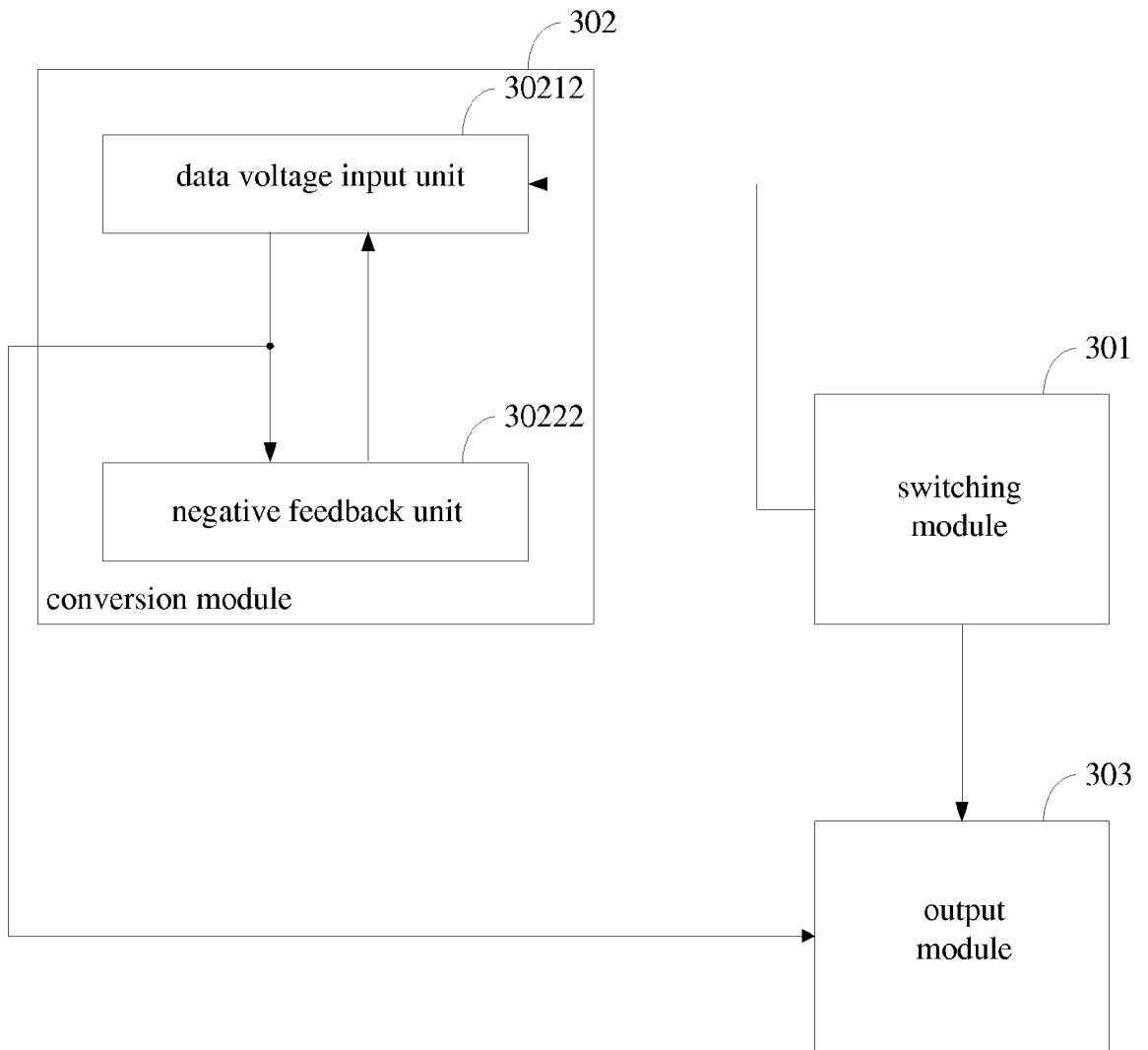

Fig.6C

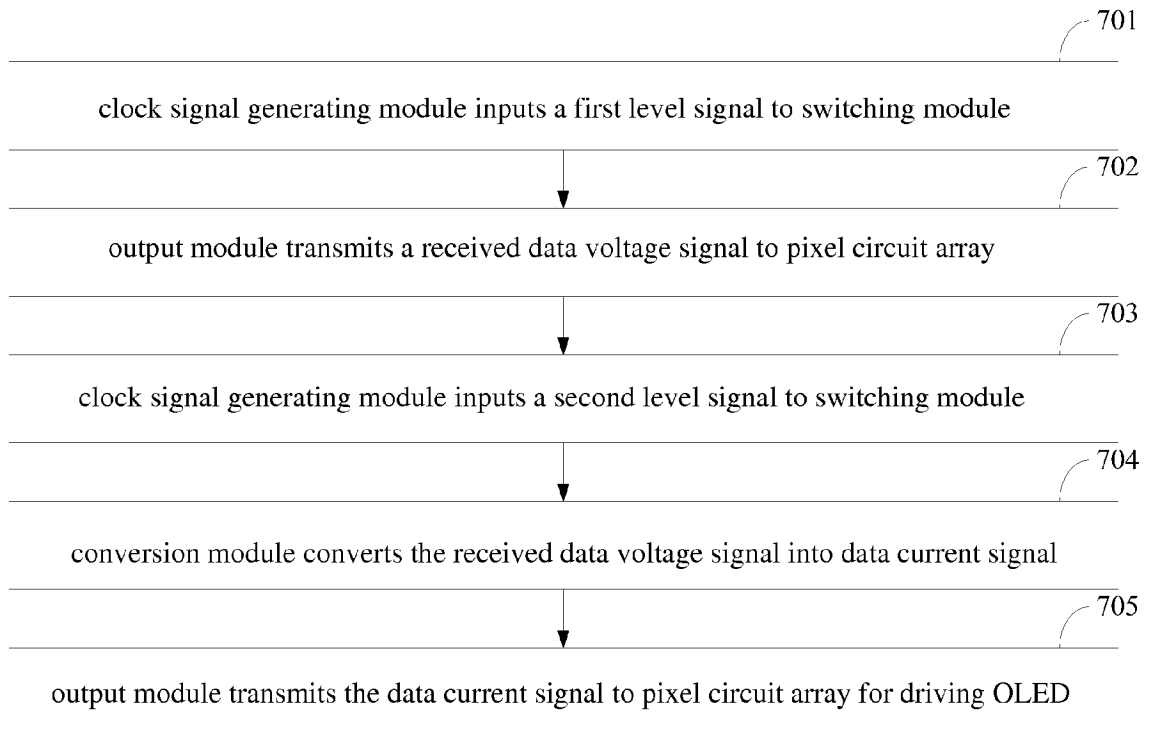

Fig.7

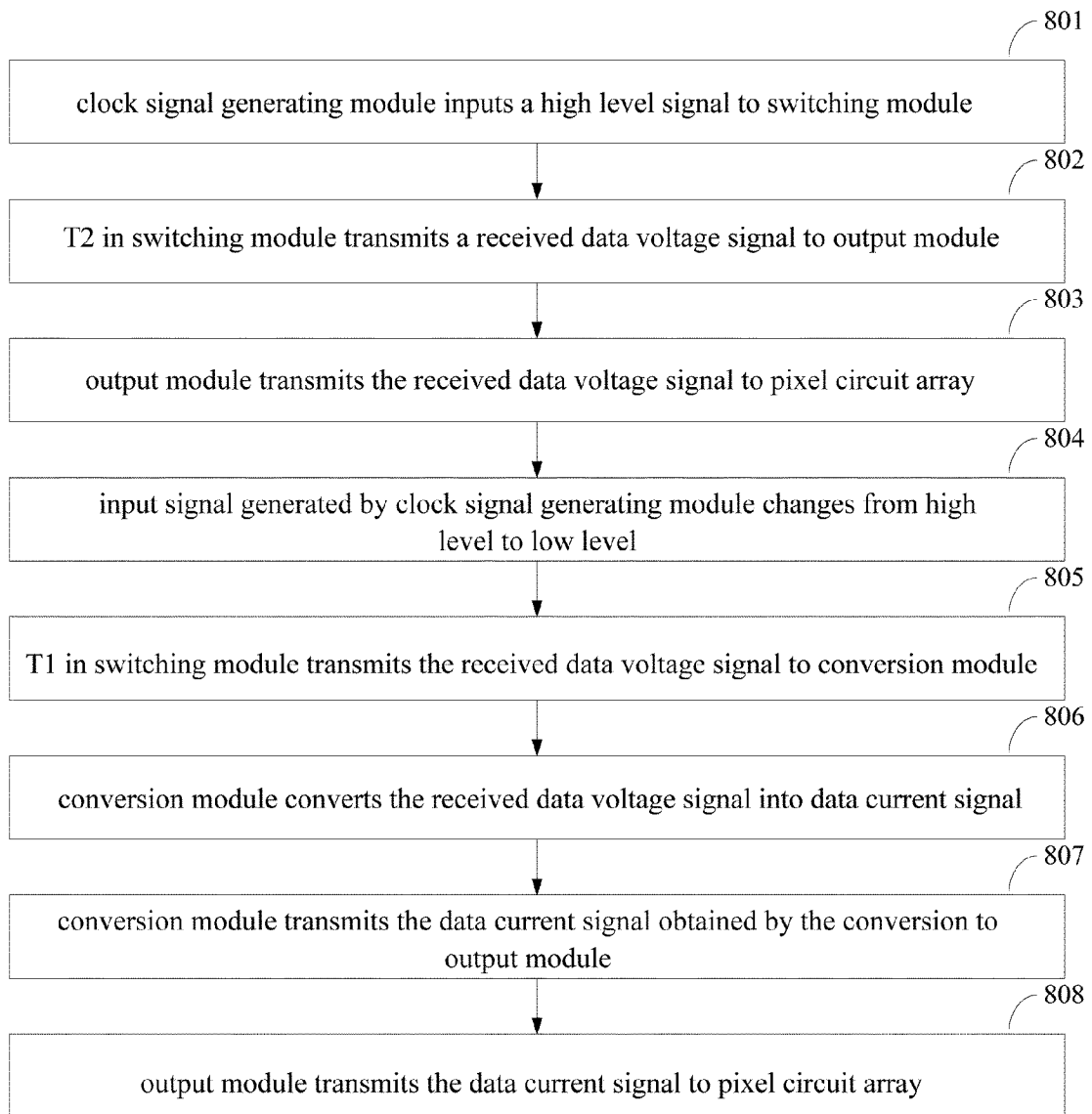

Fig.8



## EUROPEAN SEARCH REPORT

 Application Number  
 EP 12 17 0421

DOCUMENTS CONSIDERED TO BE RELEVANT			
Category	Citation of document with indication, where appropriate, of relevant passages	Relevant to claim	CLASSIFICATION OF THE APPLICATION (IPC)
X	US 2009/040212 A1 (WANG CHEN YU [TW]) 12 February 2009 (2009-02-12) * paragraphs [0019] - [0021] * * figures 1(a),1(b) * -----	1-3,10, 13-15	INV. G09G3/32
X	US 2005/168416 A1 (HASHIMOTO YOSHIHARU [JP] ET AL) 4 August 2005 (2005-08-04)  * paragraphs [0018], [0088] - [0093], [0100] * * figures 7,8 *	1-4, 8-10, 12-15	
X	US 2005/270205 A1 (JO HIROAKI [JP] ET AL) 8 December 2005 (2005-12-08)  * paragraphs [0045], [0059] - [0063], [0068] - [0072] * * figures 8,9,11 *	1-5, 8-10, 12-15	
A	US 2005/280613 A1 (TAKEI MANABU [JP] ET AL) 22 December 2005 (2005-12-22) * paragraphs [0081] - [0085] * * figure 4 * -----	8,9	
			TECHNICAL FIELDS SEARCHED (IPC)
			G09G
The present search report has been drawn up for all claims			
Place of search		Date of completion of the search	Examiner
The Hague		28 June 2012	Ladiray, Olivier
CATEGORY OF CITED DOCUMENTS			
X : particularly relevant if taken alone Y : particularly relevant if combined with another document of the same category A : technological background O : non-written disclosure P : intermediate document		T : theory or principle underlying the invention E : earlier patent document, but published on, or after the filing date D : document cited in the application L : document cited for other reasons ..... & : member of the same patent family, corresponding document	

1  
EPO FORM 1503 03.02 (P04C01)

ANNEX TO THE EUROPEAN SEARCH REPORT  
ON EUROPEAN PATENT APPLICATION NO.

EP 12 17 0421

This annex lists the patent family members relating to the patent documents cited in the above-mentioned European search report.  
The members are as contained in the European Patent Office EDP file on  
The European Patent Office is in no way liable for these particulars which are merely given for the purpose of information.

28-06-2012

Patent document cited in search report	Publication date	Patent family member(s)	Publication date
US 2009040212 A1	12-02-2009	CN 101364379 A	11-02-2009
		TW 200908552 A	16-02-2009
		US 2009040212 A1	12-02-2009
-----			
US 2005168416 A1	04-08-2005	CN 1648971 A	03-08-2005
		JP 4263153 B2	13-05-2009
		JP 2005242294 A	08-09-2005
		KR 20050078243 A	04-08-2005
		US 2005168416 A1	04-08-2005
		US 2007001939 A1	04-01-2007
-----			
US 2005270205 A1	08-12-2005	CN 1702972 A	30-11-2005
		JP 4016968 B2	05-12-2007
		JP 2005340919 A	08-12-2005
		KR 20060045998 A	17-05-2006
		TW 1277932 B	01-04-2007
		US 2005270205 A1	08-12-2005
		US 2009115769 A1	07-05-2009
-----			
US 2005280613 A1	22-12-2005	CN 1710636 A	21-12-2005
		JP 2006003752 A	05-01-2006
		KR 20060048412 A	18-05-2006
		TW 1315858 B	11-10-2009
		US 2005280613 A1	22-12-2005
		US 2011115761 A1	19-05-2011
-----			

专利名称(译)	驱动装置，oled面板和用于驱动oled面板的方法		
公开(公告)号	<a href="#">EP2530669A1</a>	公开(公告)日	2012-12-05
申请号	EP2012170421	申请日	2012-06-01
[标]申请(专利权)人(译)	京东方科技集团股份有限公司		
申请(专利权)人(译)	京东方科技集团有限公司.		
当前申请(专利权)人(译)	京东方科技集团有限公司.		
[标]发明人	LIANG YINAN MA ZHANJIE LONG CHUNPING CHENG JUN SHI LEI WANG DONGFANG JIANG CHUNSHENG LIU ZHENG		
发明人	LIANG, YINAN MA, ZHANJIE LONG, CHUNPING CHENG, JUN SHI, LEI WANG, DONGFANG JIANG, CHUNSHENG LIU, ZHENG		
IPC分类号	G09G3/32		
CPC分类号	G09G3/3283 G09G2310/0248		
审查员(译)	LADIRAY, OLIVIER		
优先权	201110147548.5 2011-06-02 CN		
其他公开文献	EP2530669B1		
外部链接	<a href="#">Espacenet</a>		

摘要(译)

本公开涉及驱动装置，OLED（有机发光二极管）面板和用于驱动OLED面板的方法。驱动装置可以集成在像素电路的基板上，并且能够提供快速且稳定的电流驱动。驱动装置包括切换模块，用于根据接收的时钟信号选择电压信号；转换模块，用于将电压信号转换为电流信号；输出模块，用于输出电压信号或转换后的电流信号以驱动像素电路阵列，其中，开关模块连接到转换模块和输出模块，转换模块连接到开关模块和输出模块。

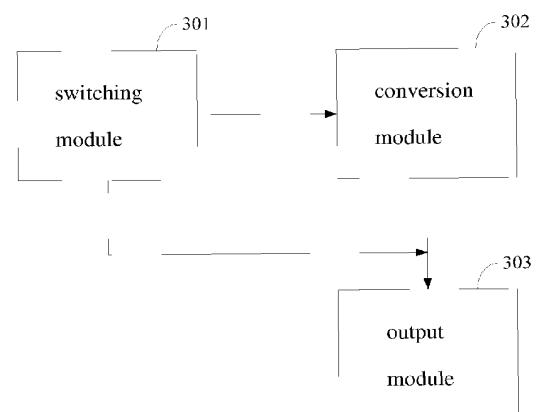

Fig.3

