



(11) **EP 2 278 639 A2**

(12) **EUROPEAN PATENT APPLICATION**

(43) Date of publication:
26.01.2011 Bulletin 2011/04

(51) Int Cl.:
H01L 51/52 (2006.01)

(21) Application number: **10169499.0**

(22) Date of filing: **14.07.2010**

(84) Designated Contracting States:
AL AT BE BG CH CY CZ DE DK EE ES FI FR GB GR HR HU IE IS IT LI LT LU LV MC MK MT NL NO PL PT RO SE SI SK SM TR
Designated Extension States:
BA ME RS

(72) Inventor: **Lee, Kyung-Jun**
446-711 Gyunggi-do (KR)

(74) Representative: **Gulde Hengelhaupt Ziebig & Schneider**
Patentanwälte - Rechtsanwälte
Wallstrasse 58/59
10179 Berlin (DE)

(30) Priority: **21.07.2009 KR 20090066525**

(71) Applicant: **Samsung Mobile Display Co., Ltd.**
Yongin-city, Gyunggi-do 446-711 (KR)

(54) **Organic light emitting diode display and method for manufacturing the same**

(57) An organic light emitting diode display comprises a display substrate including an organic light emitting element, an encapsulation substrate disposed to face the display substrate, a sealant disposed between edges of the display substrate and the encapsulation substrate for bonding and sealing the display substrate and the encapsulation substrate together, a filler filling in a space between the display substrate and the encapsulation substrate, first spacers formed on one surface of the display substrate

contacting the filler, and second spacers formed on one surface of the encapsulation substrate contacting the filler. The display substrate and the encapsulation substrate are divided into a dropping area and a spreading area surrounding the dropping area and positioned relatively close to the sealant, and either or both of the first spacers and the second spacers have different shapes in the dropping area and in the spreading area.

FIG. 1

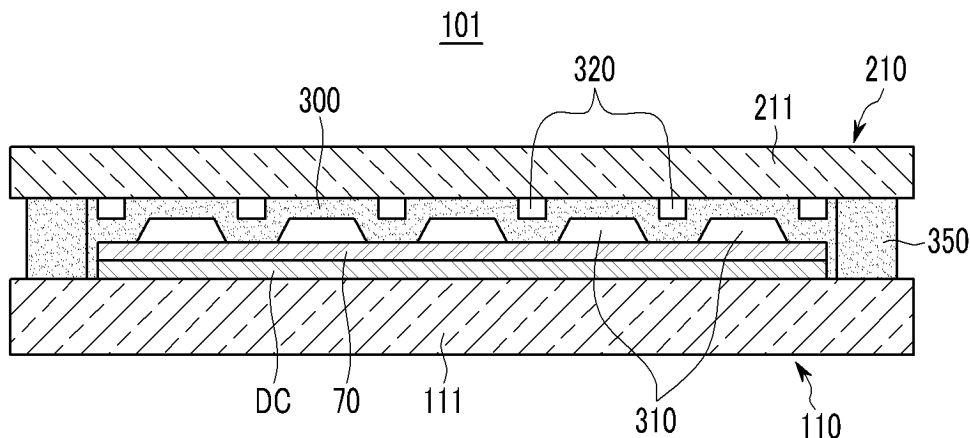

EP 2 278 639 A2

Description

BACKGROUND OF THE INVENTION

Field of the Invention

[0001] The present invention generally relates to an organic light emitting diode display and a method for manufacturing the same and, more particularly, to an organic light emitting diode display which improves durability and suppresses the generation of defects, and a method for manufacturing the same.

Description of the Related Art

[0002] Organic light emitting diode (OLED) displays have a self-emissive characteristic. Therefore, unlike liquid crystal displays, OLED displays do not require a separate light source, and thus their thickness and weight can be reduced. Furthermore, OLED displays have a variety of desirable properties, such as low power consumption, high luminance, quick response, and the like. Therefore, OLED displays are drawing attention as upcoming alternative displays for portable electronic devices.

[0003] In general, an organic light emitting display includes a display substrate having an organic light emitting element, an encapsulation substrate disposed to face the display substrate and covering the organic light emitting element of the display substrate, and a sealant for bonding and sealing the display substrate and the encapsulation substrate together. However, the mechanical strength of the organic light emitting diode display is weak due to the presence of a void between the display substrate and the encapsulation substrate.

[0004] To solve this problem, a filler is filled in the space between the display substrate and the encapsulation substrate by a vacuum bonding method to thereby improve durability against external impact.

[0005] However, if the space between the display substrate and the encapsulation substrate is filled with a filler, the filler comes in contact with the sealant formed along edges of the display substrate and encapsulation substrate. In this procedure, the filler exerts a negative effect on the curing process of the sealant to thereby make the sealant defective. Therefore, the sealant cannot stably bond and seal the display substrate and the encapsulation substrate.

[0006] The above information disclosed in this Background section is only for enhancement of understanding of the background of the invention, and therefore it may contain information that does not form the prior art which is already known in this country to a person of ordinary skill in the art.

SUMMARY OF THE INVENTION

[0007] The described technology has been made in an

effort to solve the above-mentioned problems occurring in the background art, and to provide an organic light emitting diode display which stably improves durability and suppresses the generation of defects.

5 [0008] Furthermore, the present invention provides a method for manufacturing the above organic light emitting diode display.

[0009] An organic light emitting diode display according to an exemplary embodiment comprises: a display substrate including at least one (but preferably a plurality of) organic light emitting element(s); an encapsulation substrate disposed to face the display substrate; a sealant disposed between edges of the display substrate and the encapsulation substrate for bonding and sealing the display substrate and the encapsulation substrate together; a filler filling in a space between the display substrate and the encapsulation substrate; first spacers formed on one surface of the display substrate contacting the filler; and second spacers formed on one surface of the encapsulation substrate contacting the filler; wherein the display substrate and the encapsulation substrate are divided into a dropping area and a spreading area surrounding the dropping area and positioned relatively close (i.e. preferably adjacent) to the sealant, and either or both of the first spacers and the second spacers have different shapes in the dropping area and in the spreading area.

[0010] The filler may be dropped first in the dropping area and spread out to the spreading area. Preferably, the sealant is made of epoxy or frit.

[0011] The first spacers and the second spacers may each be formed as a bar type with a length in a direction parallel to the display substrate and the encapsulation substrate, respectively, and the first spacers and the second spacers may be arranged in directions crossing each other.

[0012] The second spacers may be longer in the dropping area than in the spreading area.

[0013] The first spacers may be longer in the dropping area than in the spreading area.

[0014] The first spacers and the second spacers may be longer in the dropping area than in the spreading area.

[0015] Either or both of the first spacers and the second spacers formed in the spreading area may become gradually shorter from the dropping area.

[0016] A pair of first spacers and a pair of second spacers may be arranged in a rectangular shape in the dropping area, and the middle portion of the second spacer may be positioned between a pair of the first spacers neighboring in a longitudinal direction in the spreading area. Preferably, the thickness of the first and second spacers ranges between 2 μ m and 20 μ m, more preferably between 3 μ m and 5 μ m.

[0017] The organic light emitting element of the display substrate may display an image through a plurality of pixels emitting light, and the first spacers may be arranged in parallel with the short sides of pixels and the second spacers may be arranged in parallel with the long

sides of the pixels.

[0018] The first spacers may have a length that is less than or equal to that of the short sides of pixels, and the second spacers may have a length that is less than or equal to that of the long sides of the pixels. Preferably, the display substrate and the encapsulation substrate have planar surfaces which are arranged to be parallel to each other. Preferably, the plurality of organic light emitting elements is uniformly arranged in a matrix. Preferably, the matrix has a rectangular shape comprising a long side and a short side. Preferably, each of the plurality of organic light emitting elements comprises a rectangular shape comprising a long side and a short side. Preferably, the organic light emitting elements are arranged such that the short side of the plurality of organic light emitting elements is parallel to the long side of the matrix. Preferably, each of the first spacers comprises a rectangular shape comprising a long side and a short side. Preferably, each of the second spacers comprises a rectangular shape comprising a long side and a short side. Preferably, the first spacers are arranged such that the short side of the first spacers is parallel to the long side of the second spacers. Preferably, the first spacers are arranged such that the long side of the first spacers is parallel to the short side of the organic light emitting elements. Preferably, the first spacers are arranged such that a projection of each of the first spacers (along a first axis) onto the layer of the organic light emitting elements is positioned between adjacent organic light emitting elements, wherein the first axis is parallel to a normal vector of the display substrate and the encapsulation substrate. Preferably, the first spacers are arranged such that a projection of each of the first spacers onto the layer of the organic light emitting elements is positioned in a central portion between adjacent organic light emitting elements. Preferably, the second spacers are arranged such that a projection of each of the second spacers (along the first axis) onto the layer of the organic light emitting elements is positioned between adjacent organic light emitting elements. Preferably, the second spacers are arranged such that a projection of each of the second spacers onto the layer of the organic light emitting elements is positioned in a central portion between adjacent organic light emitting elements. Preferably, a projection of any of the first and second spacers (along the first axis) onto the layer of the organic light emitting elements does not contact any of the organic light emitting elements. That is, the projections of the first and second spacers (along the first axis) onto the layer of the organic light emitting elements are positioned between the respective organic light emitting elements. Preferably, a longitudinal extension of a spacer (whose projection is arranged between short sides of adjacent organic light emitting elements) is equal to or smaller than the short sides of adjacent organic light emitting elements. Preferably, a longitudinal extension of a spacer (whose projection is arranged between short sides of adjacent organic light emitting elements) amounts between 50 and 100% of

the short sides of adjacent organic light emitting elements. Preferably, a longitudinal extension of a spacer (whose projection is arranged between long sides of adjacent organic light emitting elements) is equal to or smaller than the long sides of adjacent organic light emitting elements. Preferably, a longitudinal extension of a spacer (whose projection is arranged between long sides of adjacent organic light emitting elements) amounts between 30 and 90% of the long sides of adjacent organic light emitting elements. Preferably, the first spacers are arranged on top of the organic light emitting elements facing towards the encapsulation substrate. Preferably, the dropping area is a central portion of the matrix.

Preferably, the spreading area is a peripheral portion of the matrix surrounding the dropping area and positioned adjacent to the sealant. Preferably, the dropping area has a rectangular shape. Preferably, the dropping area extends over 5 to 80%, more preferably 20 to 50% of the surface area of the matrix. Preferably, the spreading area extends over the residual surface area of the matrix being different from that of the dropping area. Preferably, the thickness of the first and second spacers is smaller than a distance between display substrate and the encapsulation substrate. Preferably, the display substrate further includes a pixel defining film, and the pixel defining film has a plurality of openings defining a light emitting region for each organic light emitting element, the thickness of the second spacers and the thickness of the pixel defining film are such that there is a gap (filled with filler) between the second spacers and the pixel defining film.

[0019] Furthermore, a method for manufacturing an organic light emitting diode display comprises: forming first spacers on a display substrate; forming second spacers on an encapsulation substrate; forming a sealant on edges of either or both of the display substrate and the encapsulation substrate; dropping a filler on any one of the display substrate and the encapsulation substrate; and bonding the display substrate and the encapsulation substrate together with the sealant and the filler interposed therebetween; wherein the display substrate and the encapsulation substrate are divided into a dropping area and a spreading area surrounding the dropping area and positioned relatively close to the sealant, either or both of the first spacers and the second spacers have different shapes in the dropping area and in the spreading area, and the filler is dropped in the dropping area and spread out to the spreading area along with the bonding of the display substrate and the encapsulation substrate.

[0020] The first spacers and the second spacers may each be formed as a bar type with a length in a direction parallel to the display substrate and the encapsulation substrate, respectively, and the first spacers and the second spacers may be arranged in directions crossing each other.

[0021] The second spacers may be longer in the dropping area than in the spreading area.

[0022] The first spacers may be longer in the dropping area than in the spreading area.

[0023] The first spacers and the second spacers may be longer in the dropping area than in the spreading area.

[0024] Either or both of the first spacers and the second spacers formed in the spreading area may become gradually shorter from the dropping area.

[0025] A pair of first spacers and a pair of second spacers may be arranged in a rectangular shape in the dropping area, and the middle portion of the second spacer may be positioned between a pair of the first spacers neighboring in a longitudinal direction in the spreading area.

[0026] The organic light emitting element of the display substrate may display an image through a plurality of pixels emitting light, and the first spacers may be arranged in parallel with the short sides of pixels and the second spacers may be arranged in parallel with the long sides of the pixels.

[0027] The first spacers may have a length that is less than or equal to that of the short sides of pixels, and the second spacers may have a length that is less than or equal to that of the long sides of the pixels.

[0028] The method may further include curing the sealant in a state in which the display substrate and the encapsulation substrate are bonded together.

[0029] According to the present invention, the organic light emitting diode display can stably improve durability against impact and effectively suppress the generation of a defective sealed condition.

BRIEF DESCRIPTION OF THE DRAWINGS

[0030] A more complete appreciation of the invention, and many of the attendant advantages thereof, will be readily apparent as the same becomes better understood by reference to the following detailed description when considered in conjunction with the accompanying drawings, in which like reference symbols indicate the same or similar components, wherein:

[0031] FIG. 1 is a cross-sectional view of an organic light emitting diode display according to a first exemplary embodiment.

[0032] FIG. 2 is a plan view showing the organic light emitting diode display of FIG. 1.

[0033] FIG. 3 is a cross-sectional view showing a part of a manufacturing process of the organic light emitting diode display of FIG. 1.

[0034] FIG. 4 is an enlarged layout view showing an internal structure of the organic light emitting diode display of FIG. 1.

[0035] FIG. 5 is a cross-sectional view taken along line V-V of FIG. 4.

[0036] FIG. 6 is a plan view of an organic light emitting diode display according to a second exemplary embodiment.

[0037] FIG. 7 is a plan view of an organic light emitting diode display according to a third exemplary embodiment.

[0038] FIG. 8 is a plan view of an organic light emitting

diode display according to a fourth exemplary embodiment.

[0039] FIG. 9 is a plan view of an organic light emitting diode display according to a fifth exemplary embodiment.

DETAILED DESCRIPTION OF THE INVENTION

[0040] Hereinafter, various exemplary embodiments will be described in detail with reference to the accompanying drawings so that those skilled in the art can readily carry out the invention. As those skilled in the art will realize, the described embodiments may be modified in various different ways, all without departing from the scope of the present invention.

[0041] For various exemplary embodiments, constituent elements having the same constitution are designated by the same reference numerals and are explained representatively in the first exemplary embodiment. In the other exemplary embodiments, only constituent elements that are different from those of the first exemplary embodiment are described.

[0042] In order to clarify the present invention, parts that are not related to descriptions are omitted, and the same or similar elements are given the same reference numerals throughout the specification.

[0043] Furthermore, the sizes and thicknesses of the elements shown in the drawings are arbitrarily shown for convenience of description, and thus the present invention is not necessarily limited to the illustrated ones.

[0044] In the drawings, thicknesses are magnified in order to clearly depict the plurality of layers and regions. In the drawings, the thickness of some of the layers and regions are exaggerated for clarity. It will be understood that, when an element such as a layer, film, region, or substrate is referred to as being "on" another element, it can be directly on the other element or intervening elements may also be present.

[0045] In addition, in the attached drawings, although an active matrix (AM) type of organic light emitting diode display having a 2TR-1Cap structure, which includes two thin film transistors (TFTs) and one capacitor for one pixel, is illustrated, the present invention is not limited thereto. Accordingly, the organic light emitting diode display may include three or more TFTs and two or more capacitors in one pixel. The organic light emitting display may have various structures with additional wiring. Here, a pixel refers to a minimum unit for displaying an image, and the organic light emitting diode display displays an image through a plurality of pixels.

[0046] Hereinafter, a first exemplary embodiment will be described with reference to FIGS. 1 and 2.

[0047] FIG. 1 is a cross-sectional view of an organic light emitting diode display according to a first exemplary embodiment and FIG. 2 is a plan view showing the organic light emitting diode display of FIG. 1.

[0048] As shown in FIG. 1, an organic light emitting diode display 101 according to the first exemplary embodiment includes a display substrate 110, an encapsu-

lation substrate 210, a first spacer 310, a second spacer 320, a sealant 350, and a filler 300.

[0049] The display substrate 110 includes a first substrate body 111, and a driving circuit DC and an organic light emitting element 70 formed on the first substrate body 111.

[0050] The first substrate body 111 may be formed of an insulating substrate made of glass, quartz, ceramic, plastic, or the like. However, the first exemplary embodiment is not limited thereto, and the first substrate body 111 may be formed of a metallic substrate made of stainless steel or the like.

[0051] The driving circuit DC includes thin film transistors 10 and 20 (shown in FIG. 4), and drives the organic light emitting element 70. The organic light emitting element 70 emits light in accordance with a driving signal transmitted from the driving circuit DC to display an image.

[0052] Although detailed structures of the organic light emitting element 70 and driving circuit DC are shown in FIGS. 4 and 5, the first exemplary embodiment is not limited to the structures illustrated in FIGS. 4 and 5. The organic light emitting element 70 and the driving circuit DC may be formed in various structures within the range in which those skilled in the art can readily make modifications.

[0053] The encapsulation substrate 210 is disposed to face the display substrate 110, and covers the organic light emitting element 70 and driving circuit DC of the display substrate 110. The encapsulation substrate 210 includes a second substrate body 211 formed of a transparent material such as glass, plastic, or the like. Preferably, at least one of the display substrate 110 and the encapsulation substrate 210 is formed to have at least one planar surface. Preferably, both, the display substrate 110 and the encapsulation substrate 210 are formed to have two planar surfaces.

[0054] The sealant 350 is disposed between edges of the display substrate 110 and the encapsulation substrate 210 to bond and seal the display substrate 110 and the encapsulation substrate 210 together. The sealant 350 may be made of various known materials, and is cured by a method such as heat curing or UV curing. Preferably, the sealant 350 is formed to have upper and lower planar surfaces which directly contact the planar surfaces of the display substrate 110 and the encapsulation substrate 210.

[0055] The filler 300 is disposed between the display substrate 110 and the encapsulation substrate 210 to fill a gap between the display substrate 110 and the encapsulation substrate 210. Further, the filler 300 may be made of a resin material, a liquid crystal material, or various other known materials. Preferably, the filler 300 is made of a material which is in a solid or liquid state under room temperature. That is, the material of the filler 300 has a density which improves durability against impacts by filling the void between the display substrate 110 and the encapsulation substrate 210 with a material being

denser than any kind of inert gas. Preferably, the filler 300 completely fills the void between the display substrate 110 and the encapsulation substrate 210 (and the sealant 350) in the final device, that is, preferably no air (and/or inert gas) is included in the hollow space defined by the display substrate 110, the encapsulation substrate 210 and the sealant 350.

[0056] The filler 300 improves the mechanical strength of the organic light emitting diode display 101 by filling in a void between the display substrate 110 and the encapsulation substrate 210. That is, the inside of the organic light emitting diode display 101 is filled with the filler 300, thus improving durability against external impact.

[0057] First spacers 310 are formed on one (an inner) surface of the display substrate 110 (facing towards the encapsulation substrate 210) contacting the filler 300. In addition, second spacers 320 are formed on one (an inner) surface of the encapsulation substrate 210 (facing towards the display substrate 110) contacting the filler 300. The first spacers 310 and the second spacers 320 are formed in bar shapes that have a length in a direction parallel to the display substrate 110 and the encapsulation substrate 210, respectively. In addition, the first spacers 310 and the second spacers 320 are arranged in directions crossing each other when the display substrate 110 and the encapsulation substrate 210 are bonded together.

[0058] In addition, an organic light emitting element 70 of the display substrate 110 is disposed for each pixel to emit light. As shown in FIG. 2, the display substrate 110 further includes a pixel defining film 190, and the pixel defining film 190 has a plurality of openings 199 defining a light emitting region of the organic light emitting element 70. That is, the organic light emitting element 70 emits light from a light emitting layer 720 in the openings 199. Further, the first spacers 310 are arranged in parallel with the short sides of pixels, and the second spacers 320 are arranged in parallel with the long sides of the pixels. In other words, the first spacers 310 are disposed between the short sides of neighboring pixels, and the second spacers 320 are disposed between the long sides of the neighboring pixels. However, the first exemplary embodiment is not limited thereto. Therefore, the first spacers 310 may be arranged in parallel with the long sides of pixels, and the second spacers 320 may be arranged in parallel with the short side of the pixels.

[0059] In addition, the first spacers 310 have a length that is less than or equal to that of the short sides of pixels, and the second spacers 320 have a length that is less than or equal to that of the long sides of the pixels.

[0060] In addition, the first spacers 310 and/or the second spacers 320 may be made of a material selected from the group of polyacrylate resin, polyimide resin, inorganic silica material and compositions thereof, however the invention is not limited thereto.

[0061] In addition, the display substrate 110 and the encapsulation substrate 210 are divided into a dropping

area DA and a spreading area SA surrounding the dropping area DA and positioned relatively close (i.e. adjacent) to the sealant 350 which surrounds the display area in which a plurality of OLEDs 70 are arranged (preferably in a matrix arrangement). In the first exemplary embodiment, the length of the second spacers 320 in a direction parallel to the encapsulation substrate 210 is larger in the dropping area DA than in the spreading area SA. That is, the second spacers 322 of the spreading area SA are shorter than the second spacers 321 of the dropping area DA.

[0062] Additionally, a pair of first spacers 310 and a pair of (adjacent) second spacers 320 may be arranged in a rectangular shape to surround a pixel.

[0063] In the process of bonding the display substrate 110 and the encapsulation substrate 210 together with the filler 300 interposed therebetween, the filler 300 spreads out to the spreading area SA, starting from the dropping area DA at which the filler 300 is dropped at an initial stage. At this time, the first spacers 310 and second spacers 320 of the dropping area DA control the spread and flow of the filler 300. Particularly, the second spacers 321 of the dropping area DA are longer than the second spacers 322 of the spreading area SA to thereby suppress the spread and flow of the filler 300 relatively more in the dropping area DA than in the spreading area SA. Further, as the second spacers 322 of the spreading area SA are shorter than the second spacers 321 of the dropping area DA, the filler 300 can be spread more smoothly in the spreading area SA than in the dropping area DA. In this manner, the first spacers 310 and second spacers 320 of the dropping area DA serve as a dam for confining the filler 300 and suppress a negative effect on the curing process of the sealant 350 that is caused as the filler 300 starting to be dropped first in the dropping area DA contacts the sealant 350 too quickly.

[0064] In addition, the display substrate 110 is formed as a rectangle having a pair of long sides and a pair of short sides. In the first exemplary embodiment, the long sides of the pixels are disposed in parallel with the short sides of the display substrate 110, and the short sides of the pixels are disposed in parallel with the long sides of the display substrate 110. In other words, the first spacers 310 are arranged in parallel with the long sides of the display substrate 110, and the second spacers 320 are arranged in parallel with the short sides of the display substrate 110.

[0065] Furthermore, since the dropping area DA is positioned at the center of the display substrate 110 formed in a rectangular shape, it takes different times for the filler 300, starting to be dropped first in the dropping area DA and spread out, to reach the long sides and short sides, respectively, of the display substrate 110. That is, the filler 300 contacts the sealant 350 formed along the long sides earlier than it contacts the sealant 350 formed along the short sides of the display substrate 110. Therefore, the effect of the filler 300 on the curing of the sealing 350 becomes irregular, and this may cause a defective sealed

condition of the organic light emitting diode display 101.

[0066] However, in the first exemplary embodiment, the second spacers 320 arranged in parallel with the short sides of the display substrate 110 are longer in the dropping area DA than in the spreading area SA, and the first spacers 310 have the same length in the spreading area SA and the dropping area DA. Therefore, in the spreading area SA, the spreading of the filler 300 in a direction (x-axis direction) parallel to the long sides of the display substrate 110 is more dominant than the spreading of the filler 300 in a direction (y-axis direction) parallel to the short sides thereof. Here, the direction parallel to the long sides of the display substrate 110 refers to a direction facing the short sides of the display substrate 110, and the direction parallel to the short sides of the display substrate 110 refers to a direction facing the long sides of the display substrate 110. Herein, it is possible to reduce a difference between the times taken for the filler 300 starting to be dropped first in the dropping area DA and spread out to reach the long sides and short sides, respectively, of the display substrate 110. In other words, it is possible to reduce a deviation between the times taken for the filler 300 starting to be dropped first in the dropping area DA to contact the sealant 350 formed on the short sides of the display substrate 110 and the sealant 350 formed along the long sides of the sealant 350, respectively.

[0067] By this configuration, the organic light emitting diode display 101 can stably improve durability against impact and suppress the generation of a defective sealed condition more effectively.

[0068] Moreover, in the organic light emitting diode display 101 according to the first exemplary embodiment, the first spacers 310 and the second spacers 320 serve to prevent the display substrate 110 and the encapsulation substrate 210 from contacting each other. Therefore, the first spacers 310 and the second spacers 320 have a height that is appropriate for the display substrate 110 and the encapsulation substrate 210 to maintain a stable gap. In the first exemplary embodiment, the sum of the height of the first spacers 310 and the height of the second spacers 320 is equal to the gap between the display substrate 110 and the encapsulation substrate 210, as illustrated in FIG. 1. However, the first exemplary embodiment is not limited thereto.

[0069] Hereinafter, a method for manufacturing the organic light emitting diode display 101 according to the first exemplary embodiment will be described with reference to FIG. 3.

[0070] FIG. 3 is a cross-sectional view showing a part of a manufacturing process of the organic light emitting diode display of FIG. 1.

[0071] Initially, first spacers 310 are formed on a display substrate 110, and second spacers 320 are formed on an encapsulation substrate 210. The first spacers 310 and the second spacers 320 are formed as a bar type that have a length in a direction parallel to the display substrate 110 and the encapsulation substrate 210, re-

spectively. In addition, the first spacers 310 and the second spacers 320 are arranged in a direction crossing each other when the display substrate 110 and the encapsulation substrate 210 are bonded together.

[0072] Concretely, when the display substrate 110 and the encapsulation substrate 210 are bonded together, the first spacers 310 are arranged in parallel with the short sides of pixels, i.e., the short sides of openings 199 of a pixel defining film 190 (shown in FIG. 2), and the second spacers 320 are arranged in parallel with the long sides of the pixels, i.e., the long sides of the openings 199 of the pixel defining film 190. At this time, the first spacers 310 have a length that is less than or equal to that of the short sides of the pixels, and the second spacers 320 have a length that is less than or equal to that of the long sides of the pixels.

[0073] In addition, the display substrate 110 and the encapsulation substrate 210 are divided into a dropping area DA and a spreading area SA surrounding the dropping area DA. Further, the second spacers 320 are formed so as to be longer in the dropping area DA than in the spreading area SA.

[0074] Next, a sealant 350 is formed on the display substrate 110 along an edge of the display substrate 110. The sealant 350 is disposed so as to be close to the spreading area SA. The sealant 350 is not necessarily formed on the display substrate 110, but may be formed on the encapsulation substrate 210.

[0075] Next, as shown in FIG. 3, a filler 300 is first dropped in the dropping area DA, and then the filler 300 is spread out to the edges of both substrates 110 and 210 while bonding the display substrate 110 and the encapsulation substrate 210 together. At this time, the first spacers 310 and second spacers 320 positioned in the dropping area DA serve as a dam for controlling the spreading of the filler 300. That is, the filler 300 is delayed from contacting the sealant 350 as much as possible by the first spacers 310 and second spacers 320 positioned in the dropping area DA.

[0076] Conversely, the second spacers 322 of the spreading area SA are shorter than the second spacers 321 of the dropping area DA, and this allows the filler 300 to be spread smoothly in the spreading area SA.

[0077] In this manner, the first spacers 310 and second spacers 320 of the dropping area DA suppress the filler 300 from contacting the sealant 350 too quickly, thereby minimizing a negative effect of the filler 300 on the curing process of the sealant 350.

[0078] In addition, the second spacers 322 of the spreading area SA have a length that is smaller than that of the second spacers 321 of the dropping area DA, and the first spacers 310 of the spreading area SA and the first spacers 310 of the dropping area DA have the same length. Therefore, in the spreading area SA, the spreading of the filler 300 in a direction (x-axis direction) parallel to the long sides of the display substrate 110 is more dominant than the spreading of the filler 300 in a direction (y-axis direction) parallel to the short sides thereof. There-

fore, it is possible to reduce a deviation between the times that it takes for the filler 300 starting to be dropped first in the dropping area DA to contact the sealant 350 formed on the short sides of the display substrate 110 and the sealant 350 formed along the long sides of the sealant 350, respectively.

[0079] Next, the sealant 350 is cured in a state in which the display substrate 110 and the encapsulation substrate 210 are bonded together by a vacuum bonding method, with the sealant 350 and the filler 300 interposed therebetween, to thereby completely seal the gap between the display substrate 110 and the encapsulation substrate 210.

[0080] By this manufacturing method, the organic light emitting diode display 101 can stably improve durability against impact and suppress the generation of a defective sealed condition more effectively.

[0081] Hereinafter, an internal structure of the organic light emitting diode display 101 will be described in detail with reference to FIGS. 4 and 5.

[0082] FIG. 4 is an enlarged layout view showing an internal structure of the organic light emitting diode display of FIG. 1, and FIG. 5 is a cross-sectional view taken along line V-V of FIG. 4.

[0083] As shown in FIGS. 4 and 5, the display substrate 110 includes a switching thin film transistor 10, a driving thin film transistor 20, a capacitor element 80, and an organic light emitting diode (OLED) 70 that are formed for each pixel. Here, a configuration which includes the switching thin film transistor 10, the driving thin film transistor 20, and the capacitor element 80 is referred to as a driving circuit DC. The display substrate 110 further includes a gate line 151 disposed along one direction, a data line 171 insulated from and crossing the gate line 151, and a common power supply line 172. Here, one pixel may be defined by the gate line 151, the data line 171, and the common power supply line 172, but it is not limited thereto.

[0084] The organic light emitting element 70 includes a pixel electrode 710, an organic light emission layer 720 formed on the pixel electrode 710, and a common electrode 730 formed on the organic light emission layer 720. Here, the pixel electrode 710 is an anode (+) electrode which is a hole injection electrode, and the common electrode 730 is a cathode (!) electrode which is an electron injection electrode. However, the first exemplary embodiment is not necessarily limited thereto, and the pixel electrode 710 may be a cathode electrode and the common electrode 730 may be an anode electrode according to a driving method of the organic light emitting diode display 101. Holes and electrons are respectively injected from the pixel electrode 710 and the common electrode 730 into the organic light emission layer 720. When excitons formed by combining the injected holes and electrons fall from an excited state to a ground state, they emit light.

[0085] Further, in the organic light emitting diode display 101 according to the first embodiment, the organic

light emitting element 70 emits light in the direction of the encapsulation substrate 210. That is, the organic light emitting element 70 is of a front emission type. Here, in order for the organic light emitting element 70 to emit light in the direction of the encapsulation substrate 210, a reflection-type electrode is used as the pixel electrode 710 and a transmission-type or semi-transmission-type electrode is used as the common electrode 730. However, in the first exemplary embodiment, the organic light emitting diode display 101 1 is not limited to the front emission type. Accordingly, the organic light emitting diode display 101 1 may be of a rear emission type or a both-direction emission type.

[0086] The capacitor element 80 includes a pair of capacitor plates 158 and 178 disposed with an interlayer insulating layer 160 interposed therebetween. Here, the interlayer insulating layer 160 is made of a dielectric material. The capacitance is determined by an electric charge stored in the capacitor element 80 and a voltage between the capacitor plates 158 and 178.

[0087] The switching thin film transistor 10 includes a switching semiconductor layer 131, a switching gate electrode 152, a switching source electrode 173, and a switching drain electrode 174. The driving thin film transistor 20 includes a driving semiconductor layer 132, a driving gate electrode 155, a driving source electrode 176, and a driving drain electrode 177.

[0088] The switching thin film transistor 10 is used as a switching element to select a pixel to emit light. The switching gate electrode 152 is connected to the gate line 151. The switching source electrode 173 is connected to the data line 171. The switching drain electrode 174 is spaced apart from the switching source electrode 173 and connected to the capacitor plate 158.

[0089] The driving thin film transistor 20 applies driving power to the pixel electrode 710 for allowing the organic light emission layer 720 of the organic light emitting element 70 in a selected pixel to emit light. The driving gate electrode 155 is connected to the capacitor plate 158 connected to the switching drain electrode 174. The driving source electrode 176 and the other capacitor plate 178 are respectively connected to the common power supply line 172. The driving drain electrode 177 is connected to the pixel electrode 710 of the organic light emitting element 70 via a contact hole 182.

[0090] By this structure, the switching thin film transistor 10 is operated by a gate voltage applied to the gate line 151, and serves to transmit a data voltage applied to the data line 171 to the driving thin film transistor 20. A voltage corresponding to the difference between a common voltage applied to the driving thin film transistor 20 from the common power supply line 172 and the data voltage transmitted from the switching thin film transistor 10 is stored in the capacitor element 80, and a current corresponding to the voltage stored in the capacitor element 80 flows to the organic light emitting element 70 through the driving thin film transistor 20 to thus make the organic light emitting element 70 emit light.

[0091] As shown in Fig. 5, an encapsulation substrate 210 is disposed on the organic light emitting element 70 to protect the organic light emitting element 70.

[0092] Hereinafter, a second exemplary embodiment will be described with reference to FIG. 6.

[0093] FIG. 6 is a plan view of an organic light emitting diode display according to a second exemplary embodiment.

[0094] As shown in FIG. 6, in the organic light emitting diode display 102 according to the second exemplary embodiment, the length of the first spacers 310 in a direction parallel to the display substrate 110 is larger in the dropping area DA than in the spreading area SA. That is, the first spacers 311 of the dropping area DA are longer than the first spacers 312 of the spreading area SA, and the second spacers 320 have the same length in the spreading area SA and in the dropping area DA.

[0095] By this configuration, the organic light emitting diode display 102 can stably improve durability against impact and suppress the generation of a defective sealed condition more effectively.

[0096] Further, the method for manufacturing the organic light emitting diode display 102 according to the second exemplary embodiment is the same as the method for manufacturing the organic light emitting diode display 101 according to the first exemplary embodiment except that the first spacers 310 are longer in the dropping area DA than in the spreading area SA, and the second spacers 320 have the same length in the spreading area SA and in the dropping area DA.

[0097] Hereinafter, a third exemplary embodiment will be described with reference to FIG. 7.

[0098] FIG. 7 is a plan view of an organic light emitting diode display according to a third exemplary embodiment.

[0099] As shown in FIG. 7, in the organic light emitting diode display 103 according to the third exemplary embodiment, the lengths of the first spacers 310 and the second spacers 320 in a direction parallel to the display substrate 110 and the encapsulation substrate 210, respectively, are larger in the dropping area DA than in the spreading area SA.

[0100] That is, the first spacers 311 of the dropping area DA are longer than the first spacers 312 of the spreading area SA, and the second spacers 321 of the dropping area DA are longer than the second spacers 322 of the spreading area SA.

[0101] By this configuration, the organic light emitting diode display 103 can stably improve durability against impact and suppress the generation of a defective sealed condition more effectively.

[0102] Also, the method for manufacturing the organic light emitting diode display 103 according to the third exemplary embodiment is the same as the method for manufacturing the organic light emitting diode display 101 1 according to the first exemplary embodiment, except that both the first spacers 310 and the second spacers 320 are longer in the dropping area DA than in the spreading

area SA.

[0103] Hereinafter, a fourth exemplary embodiment will be described with reference to FIG. 8.

[0104] FIG. 8 is a plan view of an organic light emitting diode display according to a fourth exemplary embodiment.

[0105] As shown in FIG. 8, either or both of the first spacers 310 and the second spacers 320 become gradually shorter toward the spreading area SA from the dropping area DA.

[0106] In FIG. 8, the length of the second spacers 321 in a direction parallel to the encapsulation substrate 210 is larger in the dropping area DA than in the spreading area SA, and the second spacers 320 of the spreading area SA become gradually shorter from the dropping area DA. That is, the second spacers 321 of the dropping area DA are the longest, and the second spacers 324 of the spreading area SA become gradually shorter from the dropping area DA. However, the present invention is not limited thereto. Accordingly, the first spacers 310 may be longer in the dropping area DA than in the spreading area SA, and the first spacers 310 of the spreading area SA may become gradually shorter from the dropping area DA. Also, both of the first spacers 310 and the second spacers 320 may become gradually shorter toward the spreading area SA from the dropping area DA.

[0107] By this configuration, the organic light emitting diode display 104 can stably improve durability against impact and suppress the generation of a defective sealed condition more effectively.

[0108] Also, the method for manufacturing the organic light emitting diode display 104 according to the fourth exemplary embodiment is the same as the method for manufacturing the organic light emitting diode display 101 according to the first exemplary embodiment, except that either or both the first spacers 310 and the second spacers 320 become gradually shorter toward the spreading area SA from the dropping area DA.

[0109] Hereinafter, a fifth exemplary embodiment will be described with reference to FIG. 9.

[0110] FIG. 9 is a plan view of an organic light emitting diode display according to a fifth exemplary embodiment.

[0111] As shown in FIG. 9, a pair of first spacers 310 and a pair of second spacers 321 are arranged in a rectangular shape in the dropping area DA of an organic light emitting diode display 105 according to the fifth exemplary embodiment, and the middle portion of a second spacer 325 is positioned between a pair of the first spacers 310 neighboring in a longitudinal direction in the spreading area SA.

[0112] That is, while the first spacers 310 and the second spacers 321 in the dropping area DA serve as a dam for controlling the flow of a filler, the second spacers 325 in the spreading area SA have an open structure so as to facilitate the flow of the filler.

[0113] Therefore, in the spreading area SA, the spreading of the filler 300 in a direction (x-axis direction) parallel to the long sides of the display substrate 110 is

more dominant than the spreading of the filler 300 in a direction (y-axis direction) parallel to the short sides thereof. Herein, it is possible to reduce a difference between the times that it takes for the filler 300 starting to be dropped first in the dropping area DA and spread out to reach the long sides and short sides, respectively, of the display substrate 110. In other words, it is possible to reduce a deviation between the times that it takes for the filler 300 starting to be dropped first in the dropping area DA to contact the sealant 350 formed on the short sides of the display substrate 110 and the sealant 350 formed along the long sides of the sealant 350, respectively.

[0114] Additionally, by this configuration, the organic light emitting diode display 104 can stably improve durability against impact and suppress the generation of a defective sealed condition more effectively.

[0115] Also, the method for manufacturing the organic light emitting diode display 105 according to the fifth exemplary embodiment is the same as the method for manufacturing the organic light emitting diode display 101 according to the first exemplary embodiment, except that the middle portion of the second spacer 325 is positioned between a pair of the first spacers 310 neighboring in a longitudinal direction in the spreading area SA.

[0116] While this disclosure has been described in connection with what is presently considered to be practical exemplary embodiments, it is to be understood that the invention is not limited to the disclosed embodiments but, on the contrary, is intended to cover various modifications and equivalent arrangements included within the scope of the appended claims.

Claims

1. An organic light emitting diode display (101), comprising:

a display substrate (110) including at least one organic light emitting element (70);

an encapsulation substrate (210) disposed to face the display substrate (110);

a sealant (350) disposed between the display substrate (110) and the encapsulation substrate (210) for bonding and sealing the display substrate (110) and the encapsulation substrate (210) together;

a filler (300) adapted for filling in a space defined by the display substrate (110), the encapsulation substrate (210) and the sealant (350);

first spacers (310) formed on an inner side of the display substrate (110) and contacting the filler (300); and

second spacers (320) formed on an inner side of the encapsulation substrate (210) and contacting the filler (300);

wherein the display substrate (110) and the en-

- capsulation substrate (210) are divided into a dropping area (DA) and a spreading area (SA) surrounding the dropping area and positioned adjacent to the sealant (350); and wherein at least one of the first spacers (310) and the second spacers (320) have different shapes in the dropping area (DA) and in the spreading area (SA).
2. The organic light emitting diode display of claim 1, wherein each of the first spacers (310) and the second spacers (320) is formed as a bar type with a length in a direction parallel to the display substrate (110) and the encapsulation substrate (210), respectively, and the first spacers (310) and the second spacers (320) are arranged in directions crossing each other.
 3. The organic light emitting diode display according to any one of the preceding claims, wherein the first spacers (310) and/or second spacers (320) are longer in the dropping area (DA) than in the spreading area (SA).
 4. The organic light emitting diode display according to any one of the preceding claims, wherein at least one of the first spacers (310) and the second spacers (320) formed in the spreading area (SA) become gradually shorter from in a direction extending from the dropping area (DA) to the sealant (350).
 5. The organic light emitting diode display according to any one of the preceding claims, wherein a pair of first spacers (310) and a pair of second spacers (321) are arranged in a rectangular shape in the dropping area (DA), and a middle portion of the second spacer (325) is positioned between a pair of the first spacers (310) neighboring in a longitudinal direction in the spreading area (SA).
 6. The organic light emitting diode display according to any one of the preceding claims, wherein each of the organic light emitting elements (70) arranged on the display substrate (110) is adapted to display an image through a plurality of pixels, and the first spacers (310) are arranged in parallel with short sides of the pixels and the second spacers (320) are arranged in parallel with long sides of the pixels.
 7. The organic light emitting diode display of claim 6, wherein the first spacers (310) have a length equal to or less than a length of the short sides of the pixels, and the second spacers (320) have a length that equal to or less than a length of the long sides of the pixels.
 8. A method for manufacturing an organic light emitting diode display (101) according to one of the preceding claims, comprising the steps of:
 - forming first spacers (310) on the display substrate (310);
 - forming second spacers (320) on the encapsulation substrate (320);
 - forming a sealant (350) in a peripheral area of at least one of the display substrate (110) and the encapsulation substrate (210);
 - dropping a filler (300) on at least one of the display substrate (110) and the encapsulation substrate (210); and
 - bonding the display substrate (110) and the encapsulation substrate (210) together with the sealant (350) and the filler (300) interposed therebetween;
 - wherein the display substrate (110) and the encapsulation substrate (210) are divided into a dropping area (DA) and a spreading area (SA) surrounding the dropping area and positioned adjacent to the sealant (350);
 - wherein at least one of the first spacers (310) and the second spacers (320) have different shapes in the dropping area (DA) and in the spreading area (SA); and
 - wherein the filler (300) is dropped in the dropping area (DA) and spread out to the spreading area (SA) along with the bonding of the display substrate (110) and the encapsulation substrate (210).
 9. The method of claim 8, wherein the filler (300) is dropped first in the dropping area (DA) and spread out to the spreading area (SA).
 10. The method according to any one of claims 8 and 9, wherein the filler (300) is only dropped in the dropping area (DA) and then spread out to the spreading area (SA).
 11. The method according to any one of claims 8 to 10, wherein the filler (300) is spread out to the spreading area (SA) by pressing together the display substrate (110) and the encapsulation substrate (210).
 12. The method according to any one of claims 8 to 11, further comprising the step of curing the sealant (350) in a state in which the display substrate (110) and the encapsulation substrate (210) are bonded together.

FIG. 1

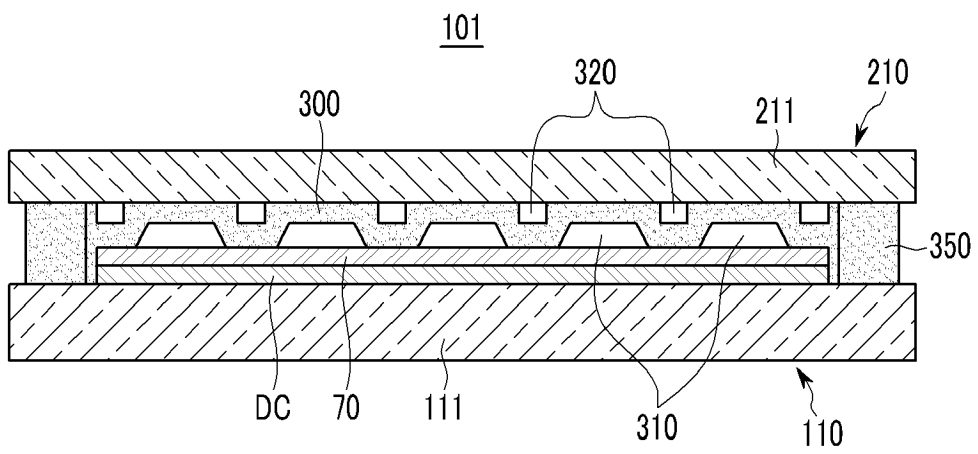

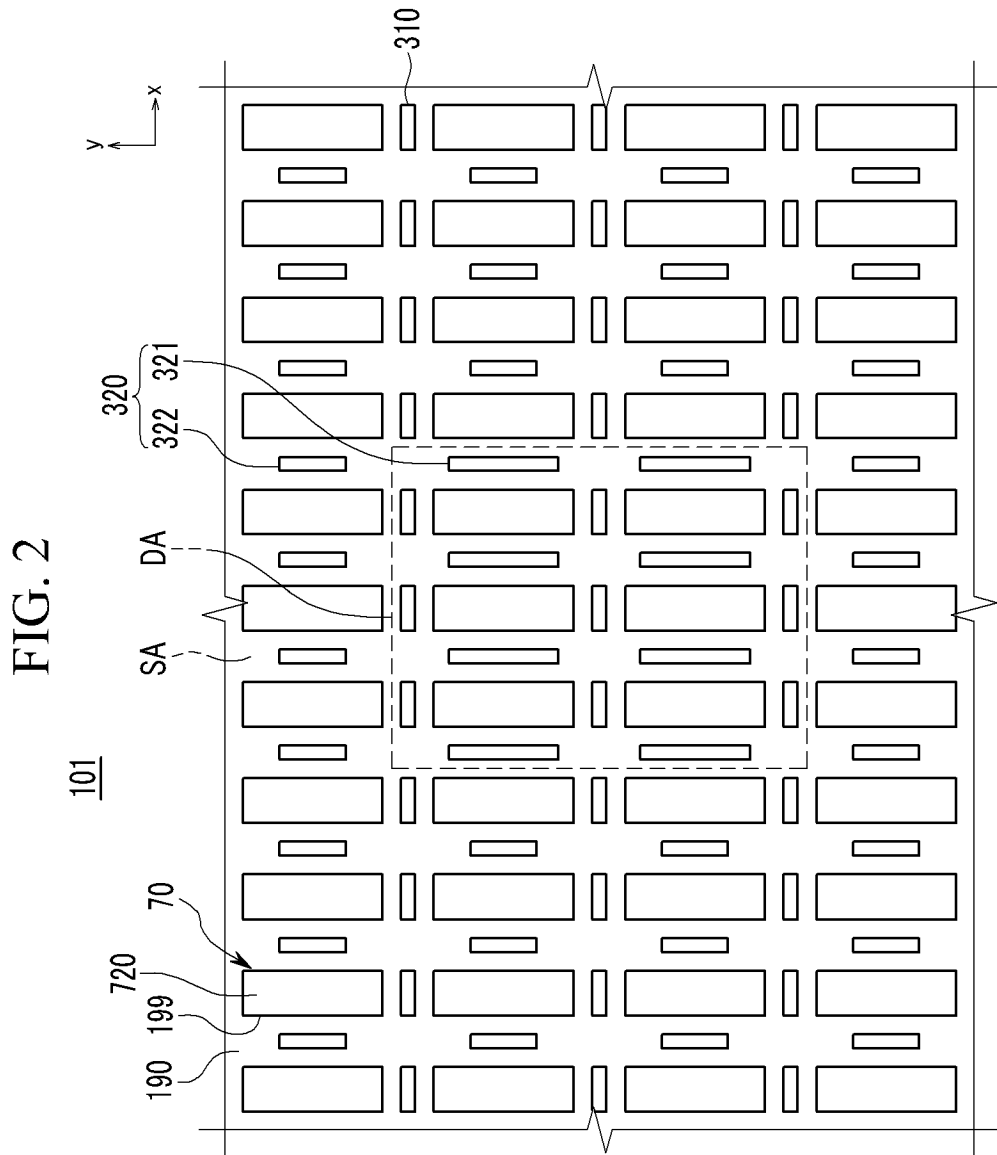

FIG. 3

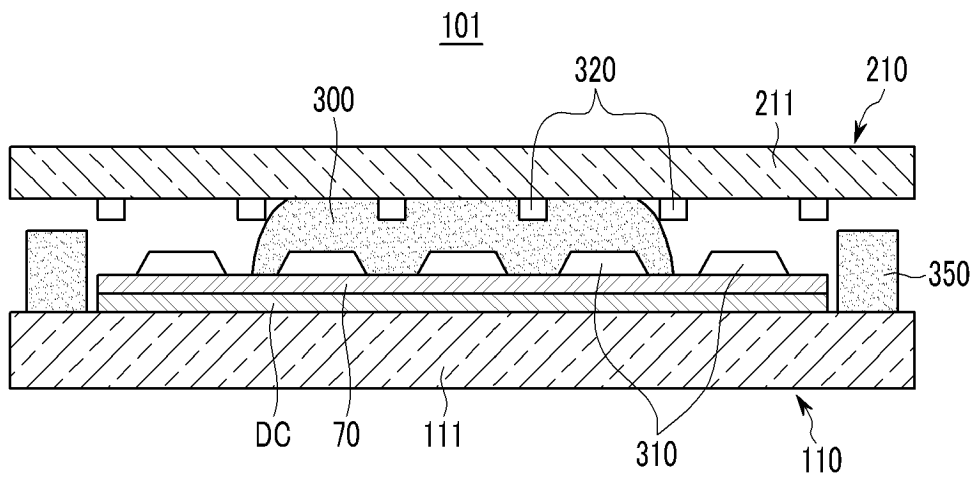

FIG. 4

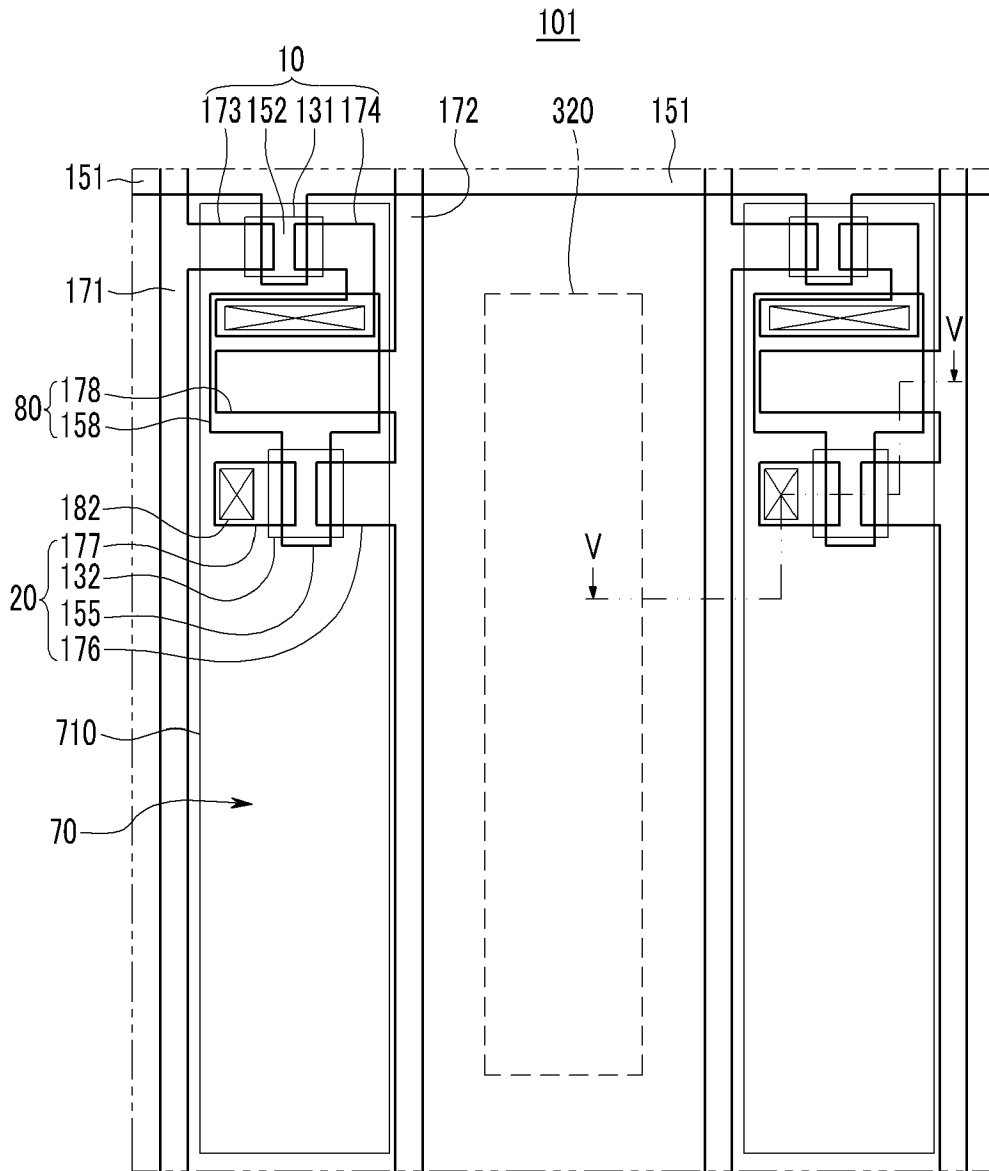

FIG. 6

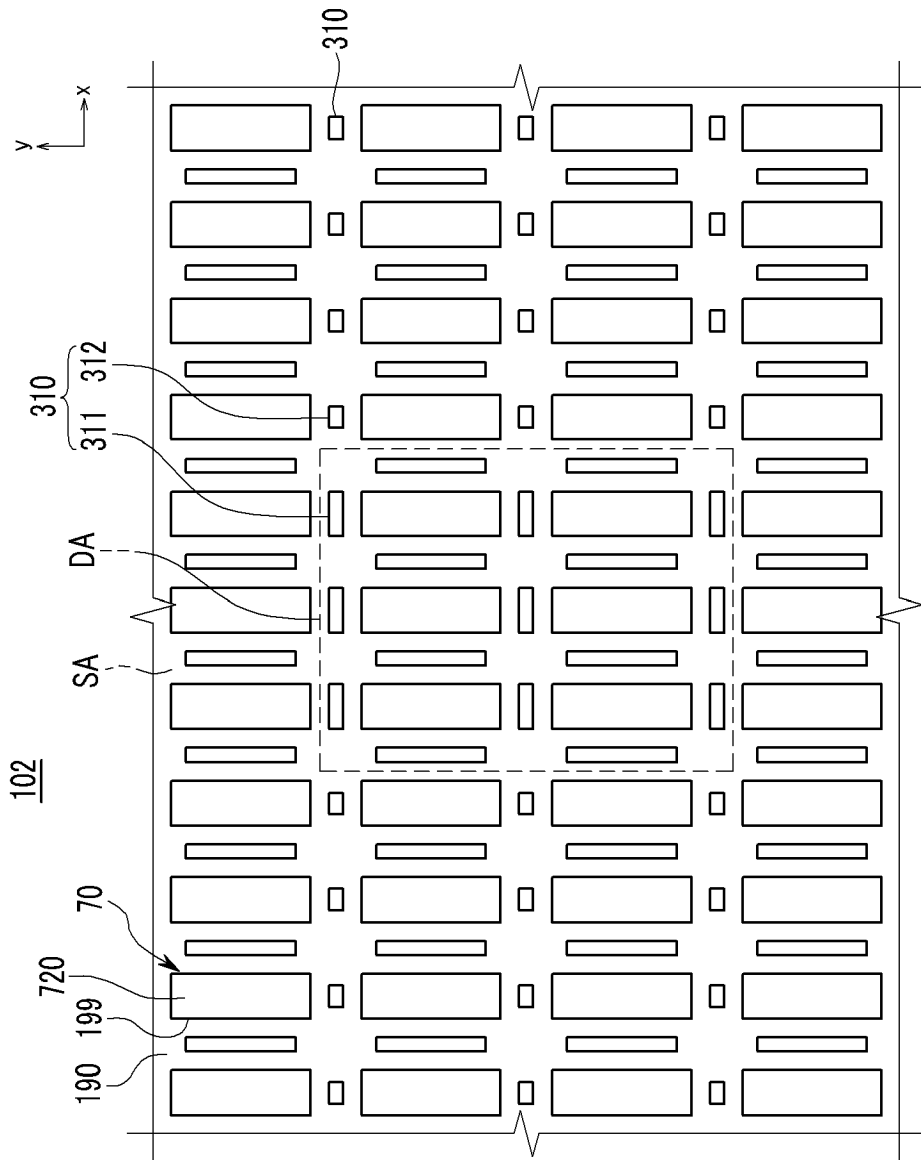

FIG. 7

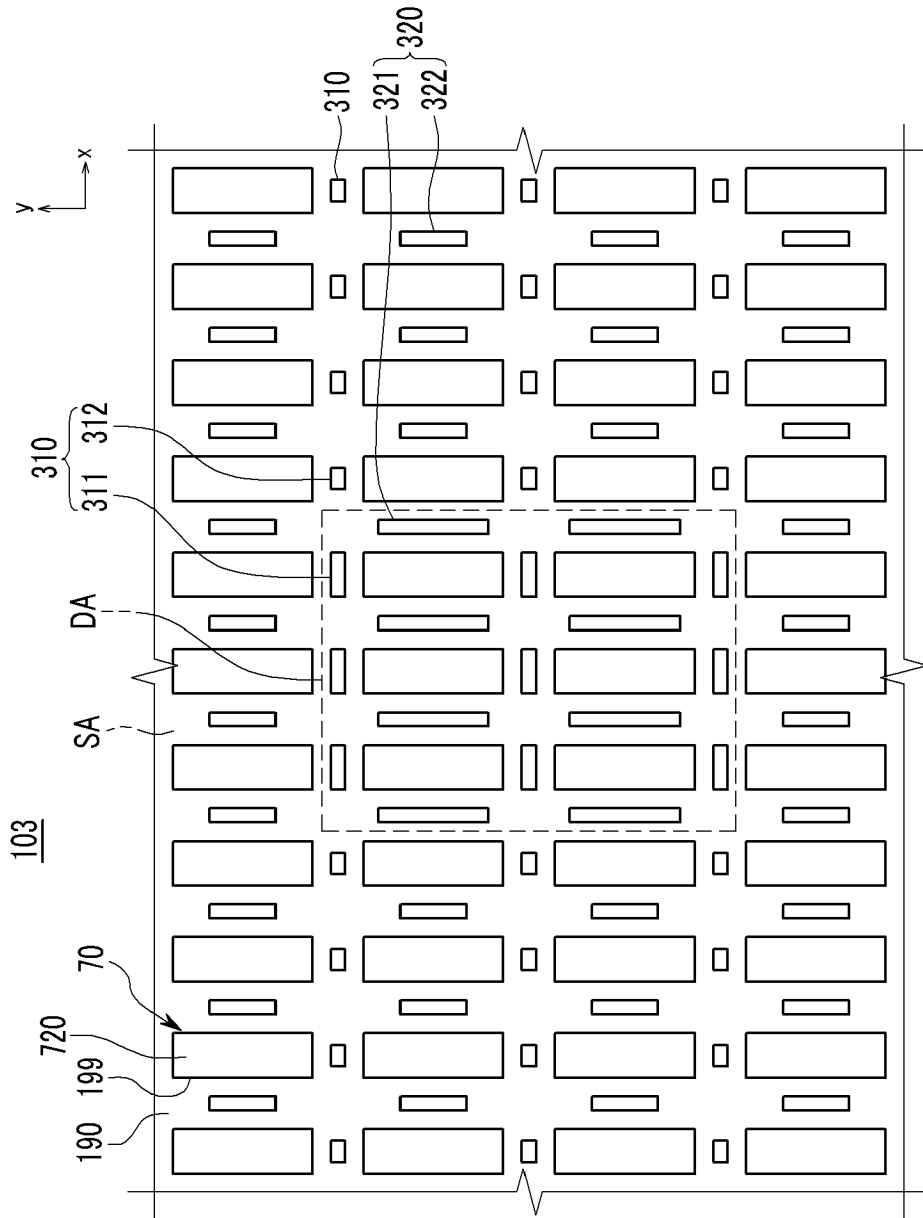
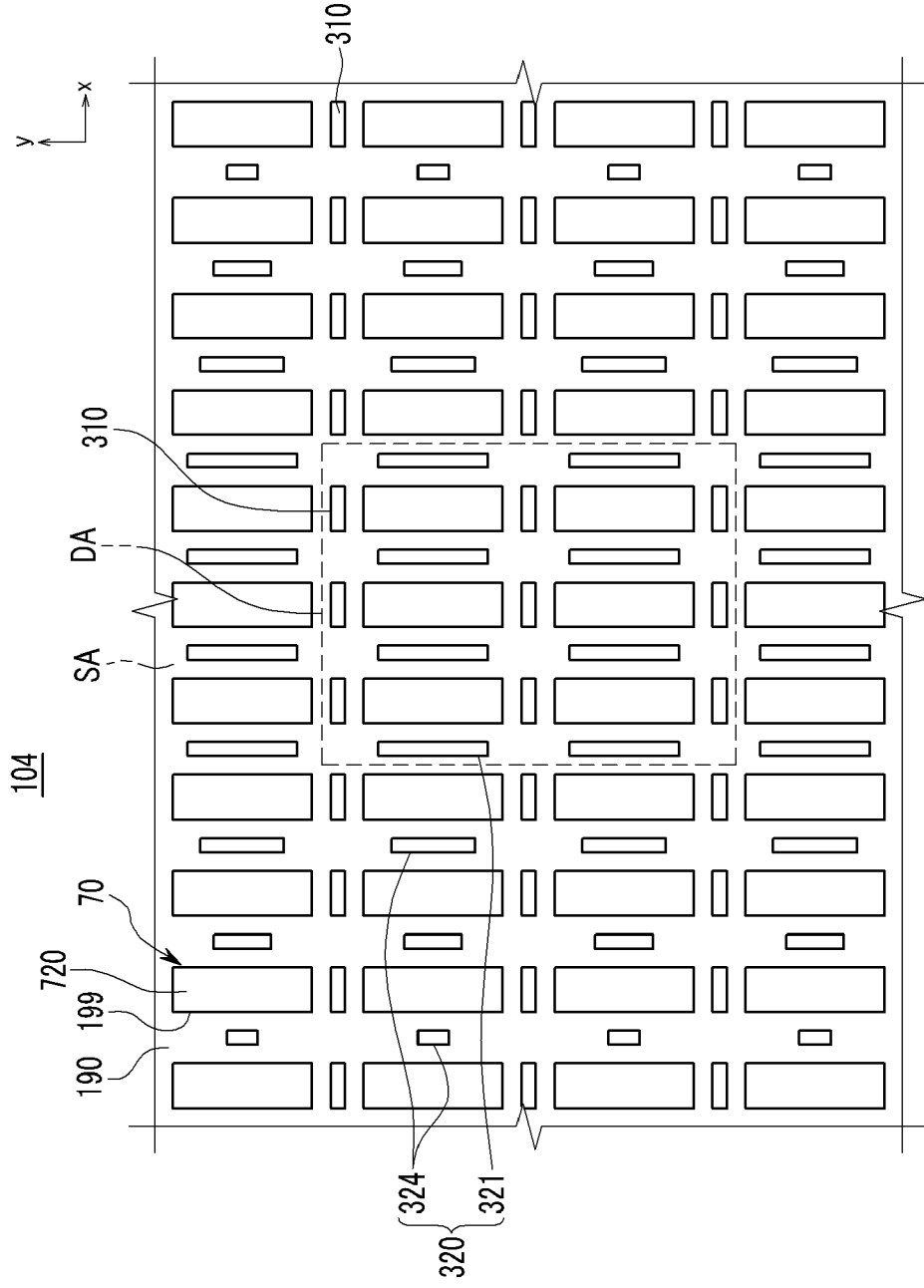
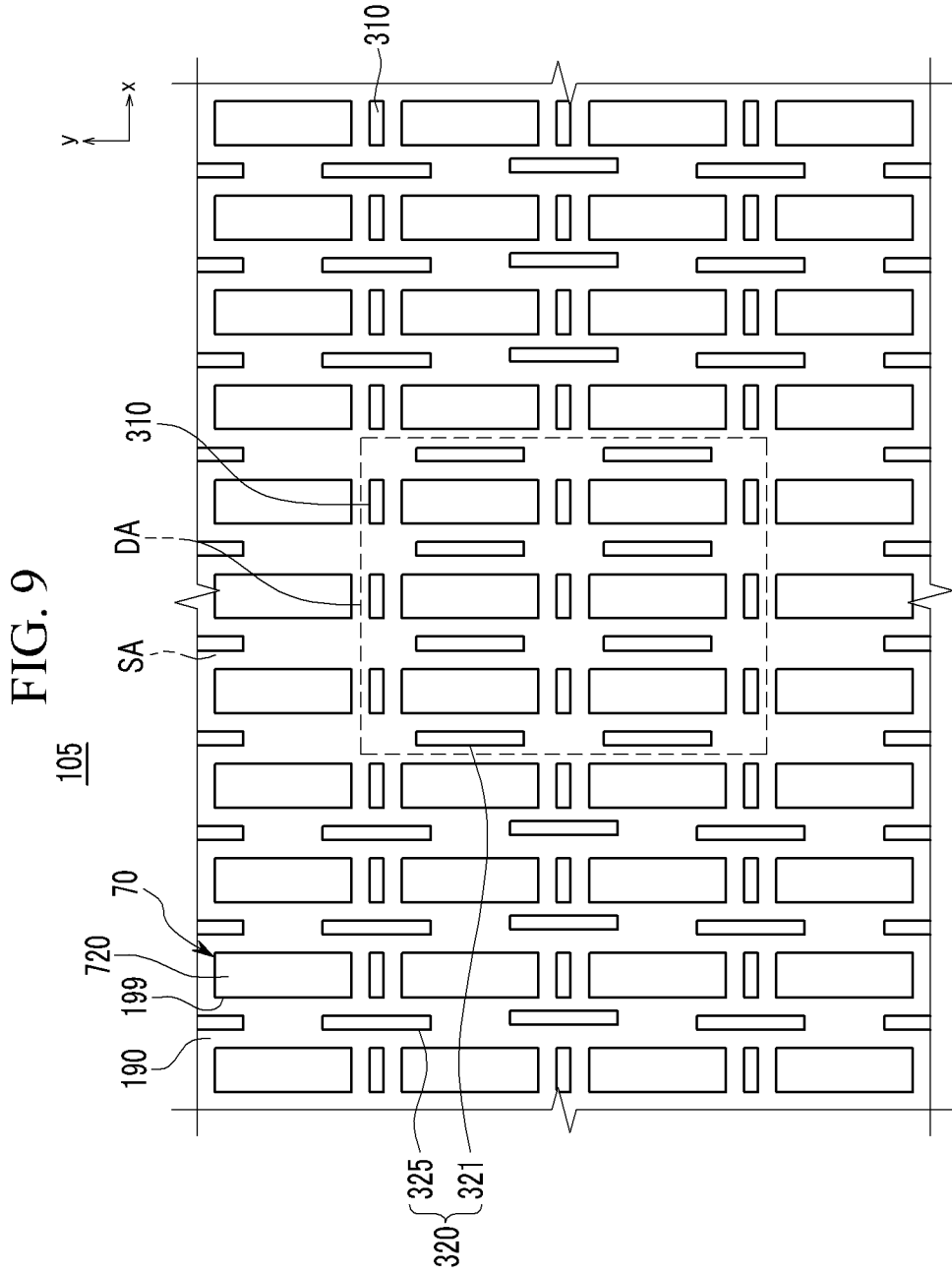

FIG. 8





专利名称(译)	有机发光二极管显示器及其制造方法		
公开(公告)号	EP2278639A2	公开(公告)日	2011-01-26
申请号	EP2010169499	申请日	2010-07-14
[标]申请(专利权)人(译)	三星显示有限公司		
申请(专利权)人(译)	三星移动显示器有限公司.		
当前申请(专利权)人(译)	三星DISPLAY CO. , LTD.		
[标]发明人	LEE KYUNG JUN		
发明人	LEE, KYUNG-JUN		
IPC分类号	H01L51/52 H01L27/32		
CPC分类号	H05B33/04 H01L27/3246 H01L51/5237 H01L51/524 H01L51/5246 H01L51/525		
优先权	1020090066525 2009-07-21 KR		
其他公开文献	EP2278639A3 EP2278639B1		
外部链接	Espacenet		

摘要(译)

一种有机发光二极管显示器，包括：显示基板，包括有机发光元件；封装基板，设置为面对显示基板；密封剂，设置在显示基板的边缘和封装基板之间，用于接合和密封显示基板和封装基板一起，填充在显示基板和封装基板之间的空间中的填充物，形成在显示基板的与填充物接触的一个表面上的第一间隔物，以及形成在封装基板的与填充物接触的一个表面上的第二间隔物。显示基板和封装基板被分成下落区域和围绕下落区域的扩散区域，并且相对靠近嵌入剂定位，并且第一间隔物和第二间隔物中的任一个或两个在下落区域中具有不同的形状。传播区域。

FIG. 1

