

(19)



(11)

**EP 2 270 896 B1**

(12)

**EUROPEAN PATENT SPECIFICATION**

(45) Date of publication and mention of the grant of the patent:  
**24.12.2014 Bulletin 2014/52**

(51) Int Cl.:  
**H01L 27/32 (2006.01)**

(21) Application number: **09700056.6**

(86) International application number:  
**PCT/JP2009/000366**

(22) Date of filing: **30.01.2009**

(87) International publication number:  
**WO 2009/107323 (03.09.2009 Gazette 2009/36)**

**(54) ORGANIC EL DISPLAY PANEL**

ORGANISCHE EL-ANZEIGETAFEL

PANNEAU D’AFFICHAGE ELECTROLUMINESCENT ORGANIQUE

(84) Designated Contracting States:  
**AT BE BG CH CY CZ DE DK EE ES FI FR GB GR HR HU IE IS IT LI LT LU LV MC MK MT NL NO PL PT RO SE SI SK TR**

- **OKUMOTO, Kenji**  
**Osaka 540-6207 (JP)**
- **YAMAMURO, Keisei**  
**Osaka 540-6207 (JP)**

(30) Priority: **28.02.2008 JP 2008047043**

(74) Representative: **Grünecker, Kinkeldey, Stockmair & Schwanhäusser**  
**Leopoldstrasse 4**  
**80802 München (DE)**

(43) Date of publication of application:  
**05.01.2011 Bulletin 2011/01**

(73) Proprietor: **Panasonic Corporation**  
**Kadoma-shi**  
**Osaka 571-8501 (JP)**

(56) References cited:  
**GB-A- 2 416 066**                    **JP-A- 2004 047 215**  
**JP-A- 2004 234 901**                **JP-A- 2004 234 901**  
**JP-A- 2005 331 665**                **JP-A- 2006 253 443**  
**JP-A- 2007 220 656**                **JP-A- 2007 335 737**  
**US-A1- 2008 024 402**

(72) Inventors:  
• **YOSHIDA, Hidehiro**  
**Osaka 540-6201 (JP)**

**EP 2 270 896 B1**

Note: Within nine months of the publication of the mention of the grant of the European patent in the European Patent Bulletin, any person may give notice to the European Patent Office of opposition to that patent, in accordance with the Implementing Regulations. Notice of opposition shall not be deemed to have been filed until the opposition fee has been paid. (Art. 99(1) European Patent Convention).

## Description

### Technical Field

**[0001]** The present invention relates to an organic EL display panel and a manufacturing method thereof.

### Background Art

**[0002]** An organic EL device, which is a display device, is a light emitting element exploiting electro-luminescence of organic compounds. An organic EL device has a cathode, an anode, and an electroluminescent organic light emitting layer provided between the electrodes. Organic light emitting layer can be roughly classified into two categories: the organic light emitting layer containing combinations of small molecular organic compounds (host material and dopant material) and the organic light emitting layer containing polymer. Examples of electroluminescent polymer include polyphenylenevinylene (also referred to as PPV) and its derivatives. Organic EL devices using polymer can be driven with a relatively low voltage, consumes small power and is suitable for manufacturing a larger display panel, and therefore is presently studied actively.

**[0003]** In an organic EL display panel using organic EL devices, organic EL elements (sub pixels) are arranged in matrix form on the substrate. In an organic EL display panel, organic EL element emits red (R), green (G), or blue (B) light.

**[0004]** An organic light emitting layer containing polymer is formed by applying a polymer ink containing, for example, organic light emitting materials and solvents, to an anode with ink jet or the like. Therefore, when an ink that contains an organic light emitting material is applied to each sub pixel of an organic EL display panel, it is necessary to prevent ink from intruding into adjacent sub pixels.

**[0005]** As a method for preventing an ink from intruding into adjacent sub pixels, defining sub pixels by banks and applying an ink inside region defined by the banks, is known (e.g. see Patent Document 1).

**[0006]** Patent Document 1 discloses a method for preventing a polymer ink from intruding into adjacent sub pixels by providing banks defining each sub pixel and by dropping a polymer ink accurately on each sub pixel.

**[0007]** Further, a technique of making the surface of an anode curved in order to improve the light emission efficiency of the organic light emitting layer is known (e.g. see Patent Documents 2 to 17).

**[0008]** Patent Documents 2 to 4 disclose techniques for improving the viewing angle of an organic EL display, by forming a plurality of concave and convex shapes on the surface of an anode of organic EL element to make an organic light emitting layer concavo-convex.

**[0009]** Patent Documents 5 to 8 disclose techniques of enlarging a surface of an anode by forming fine concave and convex shapes on the surface of an anode of

organic EL element to improve the light emission efficiency by increasing a current to supply to an organic light emitting layer.

**[0010]** Patent Document 9 discloses a technique for improving the efficiency of light emission of a pixel by forming concave parts and convex parts in an organic light emitting layer and by suppressing light emission from the convex parts.

**[0011]** Patent Documents 10 and 11 disclose techniques for efficiently utilizing light of the organic light emitting layer by making the organic light emitting layer concavely curved. Further, in Patent Documents 10 and 11, an organic light emitting layer is formed with the deposition method.

**[0012]** Patent Documents 12 to 14 disclose techniques for controlling direction of light by making an anode concavely curved and using an anode as a concave reflection mirror.

Further, in Patent Document 14, an organic light emitting layer is formed by the deposition method.

**[0013]** Patent Document 15 discloses a technique of forming an organic light emitting layer on a substrate having a curved surface and manufacturing a lighting apparatus.

**[0014]** Patent Documents 16 and 17 disclose techniques of forming a plurality of concave and convex shapes on a surface of an anode of organic EL element to reduce power consumption and to increase the aperture ratio.

**[0015]** Patent document GB 2 416 066 A describes a pattern formed object having a coating as an electroluminescent layer having even thickness, for an electroluminescent element, formed using a coating liquid and provided in each area surrounded by partition walls provided on a substrate. The pattern formed object comprises: a substrate; partition walls provided on the substrate; and a coating stacked on the substrate in its part between the partition walls. The partition walls have a sloped liquid-nonrepellent surface and have such a sectional form that, at least in the lower part of the partition wall, as the distance from the substrate increases, the size of the partition wall in a direction parallel to the substrate decreases, and, in the coating, the ratio of the maximum thickness ( $T_{max}$ ) to the minimum thickness ( $T_{min}$ ),  $T_{max}/T_{min}$ , is not more than 130% as measured in the coating in its part between the lower ends of the partition walls adjacent to each other.

**[0016]** Patent document JP 2007 220656 A aims at providing an organic EL element capable of uniform light emission by preventing emission irregularity caused by liquid stay in the bottom parts of barrier ribs. The organic EL element is characterized in that the barrier ribs have a second barrier rib on the first barrier rib, the second barrier rib being positioned on the outer side relative to the upper part of the first barrier rib.

**[0017]** US 2008/024402 A1 describes a light-emitting display having a plurality of pixels wherein each pixel comprises a light-emitting device having a light-emitting

element layer which is formed between a first electrode and a second electrode and contains at least a light-emitting layer. An insulating layer is formed between the light-emitting device and a surface of a first or second substrate on the viewing side of the display, and the insulating layer is provided with recesses and projections in at least one or more pixel regions, thereby forming an optical path length adjusting portion. By forming such an optical path length adjusting portion in a pixel region, there is an increase in the interference conditions for the light emitted from the light-emitting device to the outside, thereby averaging the interference.

**[0018]** JP2005331665 also describes an organic light-emitting display with an insulating layer having recesses.

Patent Document 1: Japanese Patent Application Laid-Open No.2006-252988

Patent Document 2: International Publication Pamphlet No.05/107327

Patent Document 3: U.S. Patent Application Publication No.2008/0024402

Patent Document 4: Japanese Patent Application Laid-Open No.2005-174914

Patent Document 5: Japanese Patent Application Laid-Open No.2007-505465

Patent Document 6: U.S. Patent Application Publication No.2005/0029538

Patent Document 7: Japanese Patent Application Laid-Open No.2004-335470

Patent Document 8: U.S. Patent Application Publication No.2004/0222740

Patent Document 9: Japanese Patent Application Laid-Open No.2004-127575

Patent Document 10: Japanese Patent Application Laid-Open No.2005-174717

Patent Document 11: Japanese Patent Application Laid-Open No.Hei10-223368

Patent Document 12: Japanese Patent Application Laid-Open No.2003-264084

Patent Document 13: U.S. Patent Application Publication No.2005/0062412

Patent Document 14: Japanese Patent Application Laid-Open No.Hei10-208875

Patent Document 15: Japanese Patent Application Laid-Open No.Hei5-47470

Patent Document 16: Japanese Patent Application Laid-Open No.2005-222935

Patent Document 17: U.S. Patent Application Publication No.2005/0174041

#### Disclosure of Invention

#### Problems to be Solved by the Invention

**[0019]** As described in Patent Document 1, when an organic light emitting layer is formed by applying an ink inside region defined by banks, a problem occurs that the thickness of the light emitting-layer becomes non-

uniform. FIG.1 shows the shape of an organic light emitting layer formed by applying an ink inside a region defined by banks and by drying the applied ink.

**[0020]** As shown in FIG.1, the ink is attracted to banks 107 in the process of drying the ink. As a result, cases occur where the center part of formed organic light emitting layer 109 is dented and the surface of organic light emitting layer 109 curves concavely. If the surface of organic light emitting layer 109 curves concavely, the organic light emitting layer near the banks becomes thick and the center part of organic light emitting layer 109 becomes thin, and therefore the thickness of organic light emitting layer 109 in the sub pixel becomes non-uniform. When voltage is applied between an organic EL element having an organic light emitting layer with non-uniform thickness, only the center part of the organic light emitting layer, where the layer is thin, emits light and the light emitting layer near the banks, where the layer is thick, does not emit light. Therefore, when the thickness of the organic light emitting layer in a sub pixel is non-uniform, the aperture ratio and light emission efficiency decrease.

**[0021]** Further, when only the center part of the organic light emitting layer emits light, the center part of the organic light emitting layer is deteriorated severely, which result in shortening the duration of the organic EL display panel.

**[0022]** It is therefore an object of the present invention to provide an organic EL display panel having a high aperture ratio and long duration.

**[0023]** This object is achieved by the present invention as claimed in the independent claims. Advantageous embodiments of the present invention are defined in the dependent claims.

**[0024]** The present inventors have found that it is possible to make the thickness of an organic light emitting layer uniform by making the shape of a part of a hole injection layer concavely curved or convexly curved on which the organic light emitting layer is formed, and have made the present invention by adding various other considerations.

**[0025]** According to a first aspect, it is provided the following organic display panel:

[1] An organic EL display panel including a substrate; linear banks placed on the substrate and defining a linear region on the substrate; and at least two organic electro luminescence elements aligned in a row in the linear region, each organic luminescence element comprising: an anode placed on the substrate; a hole injection layer made of a metal oxide and placed on the anode; an organic light emitting layer placed on the hole injection layer; and a cathode placed on the organic light emitting layer; wherein the hole injection layer is concavely curved or convexly curved; the hole injection layer is partly placed under the banks; and the organic light emitting layer is formed by applying an organic light emitting material to the linear region.

[2] The organic EL display panel described in [1] wherein the hole injection layer is concavely curved.

[3] The organic EL display panel described in [1] or [2] wherein the concavely curved hole injection layer has a depth of 50 to 300 nm.

[4] The organic EL display panel described in one of [1] to [3] wherein the banks have a forward-tapered shape.

[5] The organic EL display panel described in [4] wherein: a taper angle of the bank is 20 to 90°; a tilt angle of a tangent line at an edge of the concavely curved hole injection layer is 20 to 90 degrees as measured when the concavely curved hole injection layer is seen from a cross section which is perpendicular to a drawing direction of the linear banks.

[6] The organic EL display panel described in one of [1] to [5] wherein the metal oxide is tungsten oxide, molybdenum oxide, vanadium oxide or a combination thereof.

**[0026]** According to a second aspect, it is provided a manufacturing method of the following organic display panel:

[7] A manufacturing method of an organic EL display panel includes the steps of providing a substrate; forming at least two concavely curved parts or convexly curved parts on the substrate; forming an anode on the concavely curved part or convexly curved part; forming a hole injection layer on the anode; forming linear banks defining a linear region on the substrate, the concavely curved parts or convexly curved parts being arranged in the linear region; and applying an ink containing an organic light emitting material inside the linear region to form a linear organic light emitting layer, wherein the hole injection layer is made of a metal oxide.

[8] The manufacturing method of the organic EL display panel described in [7], wherein the substrate has a photosensitive resin layer on a surface where the concavely curved parts or the convexly curved parts are formed.

#### Advantageous Effect of the Invention

**[0027]** In the organic EL display panel of the present invention, each organic EL element has an organic light emitting layer with uniform thickness, so that the light emitting area in the organic light emitting layer is large. Consequently, the organic EL display panel of the present invention has a high aperture ratio. Further, the thickness of the organic light emitting layer is uniform, so that the organic light emitting layer is deteriorated little. Consequently, the duration of the organic EL display panel of the present invention is long.

#### Brief Description of Drawings

##### **[0028]**

- 5 FIG.1 is a cross-sectional view of an organic EL element included in a conventional organic EL display panel;
- FIG.2 is a cross-sectional view of an organic EL element included in the organic EL display panel of the present invention;
- 10 FIG.3 illustrates a manufacturing method of the organic EL display panel of the present invention;
- FIG.4 is a plan view of the organic EL display panel of Embodiment 1;
- 15 FIG.5 is a plan view of the organic EL display panel of Embodiment 1;
- FIG.6 is a perspective view of the organic EL display panel of Embodiment 1;
- FIG.7 is a cross-sectional view of the organic EL element included in the organic EL display panel of Embodiment 1;
- 20 FIG.8 is a perspective view of the organic EL display panel of Embodiment 2;
- FIG.9 is a cross-sectional view of the organic EL element included in the organic EL display panel of Embodiment 3;
- 25 FIG.10 is a cross-sectional view of the organic EL element included in the organic EL display panel of Embodiment 4 (not forming part of the invention), and
- 30 FIG.11 illustrates a manufacturing method of the organic EL display panel of Embodiment 4.

#### Best Mode for Carrying Out the Invention

- 35 1. The organic EL display panel of the present invention
- [0029]** The organic EL display panel of the present invention has a substrate and a plurality of linear banks defining a plurality of linear regions on the substrate. Organic EL elements are aligned in one row inside each linear region.
- 40 **[0030]** The feature of the organic EL display panel of the present invention lies in the shape of a hole injection layer in the organic EL element. The other configurations of the organic EL display panel of the present invention may be the same as those of known organic EL display panels as long as the effect of the present invention is not impaired. For example, the organic EL display panel of the present invention may be of a passive matrix type or of an active matrix type. Further, the organic EL display panel of the present invention may be of a bottom emission type (where light is taken out through an anode and a substrate) or top emission type (where light is taken out through a cathode and a seal film).
- 50 **[0031]** The material of the substrate varies depending on whether the organic EL display panel of the present invention is of a bottom emission type or of a top emission
- 55

type. In the case where the organic EL display panel is of a bottom emission type, the substrate is required to be transparent, so that examples of the material of the substrate contain glass and a transparent resin such as PET (polyethylene terephthalate), PEN (polyethylene naphthalate) and PI (polyimide). On the other hand, in the case where the organic EL display panel is of a top emission type, a substrate is not required to be transparent, and any substrate material can be used as long as the material of the substrate is an insulant. Further, the substrate may have built-in driving TFTs for driving the organic EL elements.

**[0032]** The banks define the area for providing the organic light emitting layer of the organic EL element (described later). In the present invention, a plurality of linear banks are formed on the substrate and define linear regions on the substrate (see FIG.5). A plurality of organic EL elements are aligned in one row in the linear region defined by the linear banks. The linear banks are preferably parallel to each other.

**[0033]** The height of the bank (the distance from the substrate surface to the top of the bank) is preferably from 0.5 to 2 $\mu$ m. Further, the bank has a forward-tapered shape and the hole injection layer is concavely curved (described later). The upper limit of the taper angle of the bank is 40 to 70°. Further, the width of the bank is preferably 60 to 80  $\mu$ m.

**[0034]** The banks preferably are lyophobic because the banks define the regions to which an ink containing an organic light emitting material (described later) is applied. To make the banks lyophobic, the banks are made of a fluorine-containing resin material. The fluorine-containing resin may be a resin which has fluorine atoms in at least part of units among the polymer repeating units.

**[0035]** Alternatively, the banks could be subjected to plasma-treatment, the material of the banks may be polyimide or an acrylic resin. Particularly, polyimide is a preferable material for the banks because polyimide has low water absorption. Further, examples of a fluorine-containing resin include a fluorinated polyimide resin, a fluorinated polymethacrylic resin, a fluorine-containing phenol novolac resin, and so on.

**[0036]** In the present invention, the structure of the bank may have a two layered structure (see FIG.9). When the bank has a two layered structure, the bank is constructed of an inorganic film, which is the lower layer, and an organic layer, which is the upper layer. Examples of the material of the inorganic film include silicon oxide, silicon nitride, silicon oxide nitride and so on, which could be treated easily by etching. The thickness of the inorganic film is 10 to 100 nm. The inorganic film may protrude from the organic layer into a linear region by 1 to 10 $\mu$ m. By making the inorganic film protrude from the organic layer into the linear region, it is possible to prevent the dust produced during the process of forming the organic layer from adhering to the hole injection layer (described later). As a result, it is possible to make the thickness of layers laminated on the anode uniform, so that the light

emission efficiency of the organic EL display panel improves substantially.

**[0037]** Further, grooves or projections may be provided on the upper surface of the banks. By providing grooves or projections on the upper surface of the banks, it is possible to prevent the ink applied inside the region defined by the banks from leaking outside the banks in a more reliable manner.

**[0038]** The organic layer material is a fluorine-containing resin as described above. Alternatively, the organic layer may be a liquid-repellent, self-assembled monolayer (SAM). The self-assembled monolayer material preferably has a silane coupling structure at the end of the organic material. When the self-assembled monolayer material has a silane coupling structure, a self-assembled monolayer is easily formed on the inorganic film. Silane coupling bonding may be cut by radiating light such as ultraviolet rays, so that the self-assembled monolayer may be patterned by radiating light using photo-mask.

**[0039]** As described above, a plurality of organic EL elements are aligned in one row inside the linear region. Each organic EL element has an anode, a hole injection layer, an organic light emitting layer and a cathode. Hereinafter, individual components of the organic EL element will be explained.

[Anode]

**[0040]** The anode is a conductive member provided on the substrate. The material of the anode varies depending on whether the organic EL display panel of the present invention is of a bottom emission type or a top emission type. In the case where the organic EL display panel is of the bottom emission type, the anode is required to be transparent, so that examples of the material of the anode include ITO (Indium Tin Oxide), IZO (Indium Zinc Oxide) and tin oxide. On the other hand, in the case where the organic EL display panel is of a top emission type, the anode is required to reflect light, so that examples of the material of the anode include APC alloy (silver-palladium-copper alloy), ARA (silver-rubidium-gold alloy), MoCr (molybdenum-chromium alloy) and NiCr (nickel-chromium alloy). The thickness of the anode may be approximately 150 nm, and is usually 100 to 500 nm.

**[0041]** Further, the anode may be connected to the drain electrode of the driving TFT. In the case where the organic EL display panel of the present invention is of a bottom emission type, the driving TFT and the organic EL element are usually arranged on the same face. On the other hand, in the case where the organic EL display panel of the present invention is of a top emission type, the organic EL element may be placed over the driving TFT.

**[0042]** Further, in the case where the organic EL display panel of the present invention is of a passive matrix type, a plurality of organic EL elements share one of linear anodes. When the anodes are linear, the drawing direc-

tion of the linear banks preferably crosses the drawing direction of the anodes at right angles. On the other hand, when the organic EL display panel of the present invention is of an active matrix type, the anodes are provided individually per organic EL element.

[Hole injection layer]

**[0043]** The hole injection layer has a function of helping the injection of holes from the anode to the organic light emitting layer (described later). Therefore, the hole injection layer is provided between the anode and the organic light emitting layer (described later). A part (end) of the hole injection layer is provided below the bank. The end of the hole injection layer are preferably covered by the bank.

**[0044]** In the present invention, the hole injection layer is made of a transition metal oxide. Examples of transition metals include tungsten, molybdenum, titanium, vanadium, ruthenium, manganese, chromium, nickel, iridium, and APC alloy (silver-palladium-copper alloy), and combination thereof. The hole injection layer preferably is made of tungsten oxide ( $WO_x$ ), vanadium oxide ( $V_xO_y$ ) or molybdenum oxide ( $MoO_x$ ), or combination thereof. The thickness of the hole injection layer is usually 10 to 100 nm and may be approximately 50 nm. In the organic EL display panel of the present invention, one hole injection layer may be shared by a plurality of elements, or the hole injection layers may be arranged per element individually.

**[0045]** A feature of the present invention lies in that the hole injection layer of each organic EL element is concavely curved (see FIG.7). The concavely curved hole injection layer means that, in the surface of the hole injection layer, the center part of the surface part contacting the organic light emitting layer (described later) is dented toward the substrate. Further, in the case of the hole injection layer is concavely curved, the surface part contacting the organic light emitting layer (described later) may be an elliptical paraboloid (see FIG.8) or parabolic cylinder (see FIG.6). On the other hand, a convexly curved hole injection layer means that, in the surface of the hole injection layer, the center part of the surface part contacting the organic light emitting layer (described later) is bulged toward the organic light emitting layer. Further, in the case where the hole injection layer is convexly curved, the surface part contacting the organic light emitting layer (described later) may be an ellipsoid or elliptical cylinder.

**[0046]** To make the hole injection layer concavely curved, for example, the hole injection layer may be formed on the concavely curved anode. The anode is concavely curved, for example, by forming concavely curved part on the substrate and by forming the anode on the concavely curved part. On the other hand, to make the hole injection layer convexly curved, for example, the hole injection layer may be formed on the convexly curved anode. The anode is convexly curved by forming

convexly curved part on the substrate and by forming the anode on the convexly curved part.

**[0047]** The shape of the hole injection layer is selected as appropriate depending on the shape of the organic light emitting layer (described later).

**[0048]** Hereinafter, the shape of the hole injection layer will be explained in detail with reference to drawings.

**[0049]** FIG.2 shows a cross-sectional view (i.e. cross-sectional view along the A-A line in FIG.5) perpendicular to the drawing direction of the linear banks of organic EL element 10 having a concavely curved hole injection layer. Further, in FIG.2, the anode and the organic light emitting layer are omitted. As shown in FIG.2, organic EL element 10 has substrate 101, anode 103, concavely curved hole injection layer 105 and bank 107.

**[0050]** Substrate 101 has concavely curved part 102. Concavely curved Anode 103 is set on concavely curved part 102. Concavely curved hole injection layer 105 is set on concavely curved anode 103.

**[0051]** As shown in FIG.2, bank 107 a forward-tapered shape in the case where the hole injection layer is concavely curved. As described above, when bank 107 has a forward-tapered shape, the taper angle of bank 107 is 40 to 70°. Tilt angle 105a of tangent line 1051 at edge 105e of concavely curved hole injection layer 105 is 20 to 50°, and preferably, the same extent to the taper angle of bank 107 (40 to 50°) as measured when concavely curved hole injection layer 105 is seen from a cross-section perpendicular to the drawing direction of linear banks 107.

**[0052]** Further, depth 105d of concavely curved hole injection layer 105 is preferably 50 to 300 nm. Here, the depth of the concavely curved hole injection layer means a distance between most dented point 105b in the surface of concavely curved hole injection layer 105 and the line linked between edges 105e of hole injection layer 105. Curvature radius 105r of concavely curved hole injection layer 105 is preferably 10 to 300  $\mu\text{m}$ , and, more preferably, 60 to 80  $\mu\text{m}$ .

**[0053]** By making the hole injection layer concavely curved or convexly curved, as mentioned above, the thickness of the organic light emitting layer (described later) is made uniform.

[Organic light emitting layer]

**[0054]** The organic light emitting layer contains an organic light emitting material. The organic light emitting layer is provided on the hole injection layer in the region defined by the banks. The thickness of the organic light emitting layer is preferably approximately 50 to 100 nm (e.g. 70 nm).

**[0055]** The organic light emitting layer is arranged in the region defined by the banks. That is, the organic light emitting layer is formed linearly inside the linear region. Therefore, the organic EL elements in one linear region share one organic light emitting layer.

**[0056]** The organic light emitting material contained in

the organic light emitting layer may be a small molecular organic light emitting material or an organic light emitting polymer material, and is preferably an organic light emitting polymer material. This is because the organic light emitting layer containing an organic light emitting polymer material can be formed easily with coating method. Examples of an organic light emitting polymer material include polyphenylenevinylene and its derivatives, polyphenylene and its derivatives, polyparaphenylene ethylene and its derivatives, poly-3-hexylthiophene (P3HT) and its derivatives, and polyfluorene (PF) and its derivatives.

**[0057]** The organic light emitting material is selected as appropriate so that a desired color (red, green, or blue) is generated from each sub pixel (organic EL element). For example, the green sub pixel is arranged next to the red sub pixel, the blue sub pixel is arranged next to the green sub pixel, and a red sub pixel is arranged next to the blue sub pixel. By applying an ink containing an organic light emitting material and a solvent to the region defined by the banks with a coating method such as ink-jetting, the organic light emitting layer is formed easily without damaging other component.

**[0058]** Further, depending on the physical properties of the ink applied, the organic light emitting layer often becomes concavely curved or convexly curved. In the present embodiment, the organic light emitting layer preferably becomes concavely curved. The physical properties of the ink having influence on the shape of the organic light emitting layer include, for example, the boiling point of the solvent and the concentration of the organic light emitting material.

**[0059]** As described above, the shape of the hole injection layer is selected as appropriate depending on shape of the organic light emitting layer. In the case where the organic light emitting layer is made concavely curved, the hole injection layer may be concavely curved, and, in the case where the organic light emitting layer is made convexly curved, the hole injection layer may be convexly curved.

**[0060]** In this way, with the present embodiment, by conforming the shape of the organic light emitting layer to the shape of the hole injection layer, it is possible to make the thickness of the organic light emitting layer uniform.

**[0061]** The interlayer may be set between the hole injection layer and the organic light emitting layer. The interlayer has a role of blocking intrusion of electrons into the hole injection layer and a role of efficiently transporting holes to the organic light emitting layer, and is made of a polyaniline material, for example. The interlayer is provided in the region defined by the banks. That is, the interlayer is formed linearly inside the linear region. Therefore, the organic EL elements in the linear region share one linear interlayer. The thickness of the interlayer is usually between 5 nm and 100 nm inclusive and is preferably between 10 nm and 50 nm inclusive (e.g. approximately 20 nm). Further, the interlayer may be omit-

ted as long as holes are efficiently transported from the hole injection layer to the organic light emitting layer.

[Cathode]

**[0062]** The cathode is provided on the organic light emitting layer. The material of the cathode varies depending on whether the organic EL display panel of the present invention is of a bottom emission type or a top emission type. In the case where the organic EL display panel is of a top emission type, the cathode is required to be optically transparent. Therefore, examples of the material of the cathode include ITO, IZO, Ba, Al, WOx and so on. Further, in the case where the organic EL display panel is of a top emission type, an organic buffer layer formed with the deposition method may be provided between the organic light emitting layer and the cathode. On the other hand, in the case where the organic EL display panel of the present invention is of a bottom emission type, the material of the cathode is not particularly limited, and, for example, Ba, BaO, and Al.

**[0063]** Further, in the case where the organic EL display panel is an active matrix type, all the organic EL elements may share one cathode (see FIG.4), because each sub pixel is driven by separate TFTs in an active matrix type organic EL display panel. On the other hand, in the case where the organic EL display panel is a passive matrix type, a plurality of linear cathodes are arranged on the panel. In this case, the linear banks can function as a cathode separator. Further the drawing direction of the linear cathodes preferably crosses the drawing direction of the linear anodes at right angles.

**[0064]** The organic EL display panel may be sealed by providing a cover material (sealing material) on the cathode. By the cover material, it is possible to reduce intrusion of moisture and oxygen into the organic light emitting layer.

**[0065]** In the organic EL display panel of the present invention, an organic EL element has an organic light emitting layer with uniform thickness, so that the light emitting area in the organic light emitting layer is large. Consequently, the organic EL display panel of the present invention has a high aperture ratio. Further, by making the thickness of the organic light emitting layer uniform, the organic light emitting layer will be deteriorated little. Therefore, the duration of the organic EL display panel of the present invention is long.

2. The manufacturing method of the organic EL display panel

**[0066]** The organic EL display panel of the present invention may be manufactured by any method as long as the effect of the present invention is not impaired.

**[0067]** The preferable manufacturing method of the organic EL display panel includes, for example: (1) the first step of providing a substrate (FIG.3A); (2) a second step of forming two or more concavely curved parts (FIGS.3B

and 3C); (3) a third step of forming an anode on the concavely curved part on the substrate (FIG.3D); (4) a fourth step of forming a concavely curved hole injection layer on the anode (FIG.3E); (5) a fifth step of forming linear banks (FIG.3F); (6) a sixth step of applying an ink containing an organic light emitting material in the region defined by the banks (i.e. linear region) to form an organic light emitting layer (FIGS.3G and 3H); and (7) a seventh step of forming a cathode on the organic light emitting layer (FIG.3I).

**[0068]** In order to form concavely curved parts on the substrate in the second step, the substrate may be directly subjected to wet etching or dry etching, or a photosensitive resin layer may be exposed and developed, which is laminated on the substrate surface which is formed to be the concavely curved parts. As described above, whether to make the hole injection layer concavely curved or convexly curved, that is, whether to form the concavely curved parts or convexly curved parts on the substrate is selected depending on the shape of the organic light emitting layer to be formed.

**[0069]** Hereinafter, the manufacturing method of the organic EL display panel of the present invention will be explained with reference to accompanying drawings in the case where the organic light emitting layer and hole injection layer are concavely curved.

**[0070]** FIG.3A shows the first step. In the first step, substrate 101 is provided. Substrate 101 has photosensitive resin layer 101'. Substrate 101 may have built-in driving TFTs.

**[0071]** FIG.3B and 3C show the second step. In the second step, concavely curved part 102 is formed on substrate 101. To form concavely curved part 102 on substrate 101, a positive photoresist is selected as the material of photosensitive resin layer 101' of substrate 101, and, photosensitive resin layer 101' may be exposed using mesh mask 113 in which the opening ratio near the center is higher than the opening ratio near the periphery, as shown in FIG.3B. After that, by developing the substrate, it is possible to obtain substrate 101 on which concavely curved part 102 is formed.

**[0072]** FIG.3D shows the third step. In the third step, anode 103 is formed on concavely curved part 102 on substrate 101. Anode 103 may be formed by forming a film made of the materials of anode 103 on concavely curved part 102 on substrate 101 with sputtering or the like, and by patterning the formed layer with etching.

**[0073]** FIG.3E shows the fourth step. In the fourth step, hole injection layer 105 is formed on anode 103. Hole injection layer 105 is formed by forming a film made of the materials of hole injection layer 105 on concavely curved anode 103 with sputtering or the like and by patterning the layer with etching. By forming hole injection layer 105 on concavely curved anode 103 with sputtering or the like as mentioned above, concavely curved hole injection layer 105 can be obtained.

**[0074]** FIG.3F shows the fifth step. In the fifth step, linear banks 107 are formed. Banks 107 may be formed

with photolithography or printing technologies.

**[0075]** Formation of banks using the photolithography technologies includes the steps of (a) forming film of a photosensitive resin composition containing a resin on substrate 101 and hole injection layer 105 (b) exposing and developing the film so as to expose at least part of hole injection layer 105.

**[0076]** A film of a photosensitive resin composition containing a resin on substrate 101 and hole injection layer 105 is formed by, for example, applying a resin composition using spin-coating, forming a film made of the resin composition; and drying the film made of the resin composition. The drying condition is not particularly limited, and the films may be left for 2 to 3 minutes at 80 °C.

**[0077]** By exposing and developing the film of the photosensitive resin composition containing the resin, hole injection layer 105 is exposed in the linear region in which the ink containing the organic light emitting material (described later) is to be applied.

**[0078]** The developed film is subjected to baking treatment. Although the condition of the baking treatment is not particularly limited, the temperature is approximately 200 °C or more and the time period is approximately one hour, for example.

**[0079]** On the other hand, the printing technology, a technique such as intaglio printing, relief printing or the like may be used to form a patterned resin film. If banks 107 are formed by intaglio printing or the like, other component members will be damaged little.

**[0080]** The manufacturing method of the organic EL display panel of the present invention may include a step of forming an inorganic film between the fourth step and fifth step. The inorganic film is formed with inorganic material using the CVD method. The formed inorganic film may be subject to dry-etching with gas including SiF and CF<sub>4</sub> to be patterned.

**[0081]** FIGS.3G and 3H show the sixth step. In the sixth step, organic light emitting layer 109 is formed on hole injection layer 105. Organic light emitting layer 109 is formed by applying ink 108 containing an organic light emitting material and solvent to the region defined by banks 107 (i.e. linear region) (FIG.3G), and by drying the ink applied. Examples of the solvent include an aromatic system solvent, for example, anisole. The applying means is not particularly limited. Examples of the applying means include ink-jet, dispenser, nozzle coating, spin coating intaglio printing, relief printing or the like. The preferable applying means is ink-jet.

**[0082]** Organic light emitting layer 109 formed by drying ink 108 becomes concavely curved. Therefore, when the region on which organic light emitting layer 109 is formed is flat, the thickness of organic light emitting layer 109 of each organic EL element 10 will become non-uniform (see FIG.1).

**[0083]** However, in the present invention, hole injection layer 105 in the region in which organic light emitting layer 109 is formed is also concavely curved. Consequently, even if organic light emitting layer 109 becomes

concavely curved, the thickness of organic light emitting layer 109 on hole injection layer 105 is uniform.

**[0084]** The manufacturing method of the present invention may have a step of forming an interlayer between the fifth step and the sixth step. The interlayer is formed by applying ink containing the material of the interlayer and solvent to the region defined by the banks.

**[0085]** FIG.3I shows the seventh step. In the seventh step, cathode 111 is formed on organic light emitting layer 109. Cathode 111 is formed with, for example, the deposition method or sputtering. After that, a seal film may be formed on the cathode to prevent moisture or oxygen from intruding into organic light emitting layer.

**[0086]** In this way, with the manufacturing method of the organic EL display panel of the present invention, it is possible to make the thickness of the organic light emitting layer in the organic EL element uniform, so that the aperture ratio of the organic EL display panel improves and the light emission efficiency improves. Further, when the thickness of the organic light emitting layer is uniform, it is possible to extend the life of an organic EL display panel and reduce power consumption.

**[0087]** Hereinafter, embodiments of the present invention will be described with reference to the accompanying drawings. However, the present invention is not limited to these embodiments.

(Embodiment 1)

**[0088]** In Embodiment 1, an active matrix type organic EL display panel will be described.

**[0089]** FIG.4 is a plan view of organic EL display panel in Embodiment 1. As shown in FIG.4, organic EL display panel 100 has cathode 111 covering the entire panel.

**[0090]** FIG.5 is a plan view of organic EL display panel 100 omitting cathode 111. As shown in FIG.5, organic EL display panel 100 has linear banks 107 aligned in parallel to each other on substrate 101. Linear banks 107 define linear regions 11. A plurality of organic EL elements 10 are aligned in one row in linear region 11. Organic light emitting layer 109 is arranged linearly in linear region 11. Organic EL elements 10 aligned in linear region 11 share linear organic light emitting layer 109.

**[0091]** Organic EL elements 10 aligned in linear region 11R emit red light, organic EL elements 10 aligned in linear region 11G emit green light and organic EL elements 10 aligned in linear region 11B emit blue light. Linear regions 11 are each defined by the banks, and therefore the inks applied in the regions will not become mixed. Further, by forming the organic light emitting layer linearly, the thickness of the organic light emitting layer becomes uniform in the linear direction.

**[0092]** FIG.6 is a perspective view of organic EL display panel 100 omitting cathode 111, organic light emitting layer 109 and interlayer 104 from organic EL display panel shown in FIG.5. As shown in FIG.6, substrate 101 has convexly curved parts 102 in the shape of a parabolic cylinder. Anode 103 and hole injection layer 105 are

formed on concavely curved part 102, so that, in the present embodiment, hole injection layer 105 is concavely curved, and the surface of hole injection layer 105 contacting the organic light emitting layer has a shape of a parabolic cylinder. Further, the surface of region 12 between the organic EL elements has a shape of a parabolic cylinder. By making region 12 between the organic EL elements concavely curved, even when foreign substances such as particles are intruded on region 12 before forming the organic light emitting layer, it is possible to hold foreign substances in region 12 and prevent foreign substances from intruding on organic EL element. Hereinafter, the organic EL element included in organic EL display panel 100 of Embodiment 1 will be described in detail.

**[0093]** FIG.7 shows organic EL element 10 of cross-sectional view of organic EL display panel 100 along A-A line shown in FIG.5. Organic EL element 10 has substrate 101, anode 103, hole injection layer 105, banks 107, interlayer 104 and organic light emitting layer 109.

**[0094]** Substrate 101 has built-in driving TFTs. Substrate 101 has gate electrode 201, source electrode 203 and drain electrode 205. Gate insulating film 211 insulates gate electrode 201 from source electrode 203 and drain electrode 205. Channel 207 connects source electrode 203 and drain electrode 205. Further, flattening film 213 is placed over channel 207, source electrode 203 and drain electrode 205. Drain electrode 205 and anode 103 are connected via contact hole 209.

**[0095]** As shown in FIG.7, anode 103 and hole injection layer 105 is concavely curved. By making hole injection layer 105 concavely curved as mentioned above, the thickness of interlayer 104 and organic light emitting layer 109 formed on hole injection layer with coating method 105 becomes uniform.

**[0096]** In this way, in the present embodiment, the thickness of organic light emitting layer is uniform. Further, it is possible to reduce the decrease of the yield caused by particles.

(Embodiment 2)

**[0097]** In Embodiment 1, the case is explained where the surface of the concavely curved hole injection layer has a shape of a parabolic cylinder. In Embodiment 2, a case will be explained with an example where the surface of concavely curved the hole injection layer has a shape of an elliptical paraboloid.

**[0098]** FIG.8 is a perspective view of organic EL display panel 200 of Embodiment 2 omitting the cathode, the organic light emitting layer and the interlayer. Organic EL display panel 200 is the same as organic EL display panel 100 except the shape of concavely curved part 102a substrate 101 has. Therefore, the same reference numerals are assigned to the same components as in organic EL display panel 100 and the explanation thereof will be omitted.

**[0099]** As shown in FIG.8, substrate 101 has concavely

curved parts 102a aligned in a row in linear region 11. The surface of concavely curved part 102a has a shape of an elliptical paraboloid. In Embodiment 2, each organic EL element is formed on concavely curved part 102a. Therefore, the hole injection layer of each organic EL element is concavely curved and the surface of the hole injection layer has a shape of an elliptical paraboloid.

**[0100]** In the present embodiment, each surface of the concavely curved hole injection layer has a shape of an elliptical paraboloid, so that it is possible to make the thickness of the organic light emitting layer uniform and improve the aperture ratio.

(Embodiment 3)

**[0101]** With Embodiments 1 and 2, examples where the bank has a one-layered structure are explained. With Embodiment 3, an example where the bank has a two-layered structure will be explained.

**[0102]** A plane view of the organic EL display panel of Embodiment 3 is the same as of organic EL display panel 100 shown in FIGS.4 and 5 of Embodiment 1.

**[0103]** FIG.9 is a cross-sectional view of organic EL element 20 included in organic EL display panel of Embodiment 3. Organic EL element 20 is the same as organic EL element 10 other than having an inorganic film. Therefore, the same reference numerals are assigned to the same components as in organic EL element 10 and the explanation thereof will be omitted.

**[0104]** As shown in FIG.9, organic EL element 20 has inorganic film 106 placed under bank 107. Inorganic film 106 is placed on substrate 101 such that inorganic film cover the end of hole injection layer 105. Further, inorganic film 106 protrudes from bank 107 into the region defined by banks 107. The width d of inorganic film 106 protruded from banks 107 is 1 to 10 μm.

**[0105]** By providing high lyophilic inorganic film under the organic bank as mentioned above, it is possible to apply an ink to the edge of the region defined by banks, so that no area is left unapplied. This makes it possible to prevent organic EL elements from shorting.

**[0106]** By making inorganic film protrude from an organic layer into the linear region, it is possible to prevent the dust produced during the process of forming the organic layer from adhering to a hole injection layer.

As a result, it is possible to make the thickness of layers piled over an anode uniform, so that the light emission efficiency of the organic EL display panel improves substantially.

(Embodiment 4)

**[0107]** In Embodiments 1 to 3, examples where the hole injection layer is concavely curved are explained. In Embodiment 4, an example where the hole injection layer is convexly curved will be explained. That is, a case will be explained where the organic light emitting layer becomes convexly curved.

**[0108]** A plan view of the organic EL display panel of Embodiment 4 is the same as of organic EL display panel 100 shown in FIGS.4 and 5 of Embodiment 1.

**[0109]** FIG.10 is a cross-sectional view of organic EL element 30 included in organic EL display panel of Embodiment 4. As shown in FIG.10, organic EL element 30 has substrate 101, anode 103, hole injection layer 105, banks 107, interlayer 104 and organic light emitting layer 109. A feature of the present embodiment includes that anode 103 and hole injection layer 105 are convexly curved. Further, substrate 101 has convexly curved part 102'.

**[0110]** Hereinafter, the manufacturing method of the organic EL display panel of Embodiment 4 will be explained with reference to the accompanying drawings.

**[0111]** FIG.11 shows a manufacturing process of organic EL display panel in Embodiment 4. As shown in FIG.11, the manufacturing method of the organic EL display panel in Embodiment 4 includes: ( 1) the first step of providing substrate 101 (FIG.11A); (2) a second step of forming convexly curved part 102' on substrate 101 (FIGS.11B and 11C); (3) a third step of forming anode 103 on convexly curved part 102' on substrate 101 (FIG.11D); (4) a fourth step of forming convexly curved hole injection layer 105 on anode 103 (FIG.11E); (5) a fifth step of forming banks 107 (FIG.11F); and (6) a sixth step of forming interlayer 104 and organic light emitting layer 109 inside the region defined by banks 107 (FIGS.11G).

**[0112]** In the second step, in order to form convexly curved part 102' on substrate 101, positive photoresist is selected as the material of photosensitive resin layer 101' of substrate 101 and photosensitive resin layer 101' may be exposed using mesh mask 113 in which the opening ratio near the center is lower than the opening ratio near the periphery, as shown in FIG.11B. After that, by developing the substrate, substrate 101 can be obtained on which convexly curved part 102' is formed.

**[0113]** By making a hole injection layer convexly curved, it is possible to acquire an organic light emitting layer with uniform thickness even when the light emitting layer becomes convexly curved.

Industrial Applicability

**[0114]** The organic EL display panel of the present invention is applicable to, for example, organic EL displays (e.g. large screen televisions and monitors of information equipments including mobile phones).

[Explanation of Reference Numerals]

**[0115]**

- 55 101 SUBSTRATE
- 103 ANODE
- 104 INTERLAYER
- 105 HOLE INJECTION LAYER

106 INORGANIC FILM  
 107 BANK  
 108 INK  
 109 ORGANIC LIGHT EMITTING LAYER  
 111 CATHODE  
 113 MASK  
 201 GATE ELECTRODE  
 203 SOURCE ELECTRODE  
 205 DRAIN ELECTRODE  
 207 CHANNEL  
 209 CONTACT HOLE  
 211 GATE INSULATING FILM  
 213 FLATTENING FILM

### Claims

1. An organic electroluminescence display panel comprising:

a substrate (101) having concavely curved parts thereon;  
 linear banks (107) placed on the substrate (101) and defining a linear region (11) on the substrate (101), the linear banks (107) being made of fluorine-containing resin and having a forward-tapered shape with a taper angle of 40 to 70 degrees; and  
 at least two organic electroluminescence elements (10) aligned in a row in the linear region (11), each organic electroluminescence element (10) including:

an anode (103) placed on the concavely curved part;  
 a hole injection layer (105) made of a metal oxide and placed on the anode (103);  
 an organic light emitting layer (109) placed on the hole injection layer (105) and being in contact with a forward-tapered surface of the linear bank (107); and  
 a cathode (111) placed on the organic light emitting layer (109);

wherein the hole injection layer (105) is concavely curved,  
 the hole injection layer (105) is partly placed under the banks (107) such that an end of the hole injection layer (105) is covered by the banks (107),  
 the tilt angle (105a) between the plane of the substrate and the tangent line (105l) at an edge (105e) of the concavely curved hole injection layer (105) is 20 to 50 degrees as measured when the concavely curved hole injection layer (105) is seen from a cross section which is perpendicular to the direction of the linear banks (107), and

the organic light emitting layer (109) is formed inside the linear region (11).

2. The organic electroluminescence display panel according to claim 1, wherein the concavely curved hole injection layer (105) has a depth (105d) of 50 to 300 nanometers.
3. The organic electroluminescence display panel according to claim 1, wherein the metal oxide is tungsten oxide, molybdenum oxide, vanadium oxide or a combination thereof.
4. A manufacturing method of an organic electroluminescence display panel comprising the steps of:

providing a substrate (101);  
 forming at least two concavely curved parts on the substrate (101);  
 forming an anode (103) on the concavely curved parts;  
 forming a hole injection layer (105) on the anode (103);  
 forming linear banks (107) defining a linear region (11) on the substrate (101), the linear banks (107) having a forward-tapered shape with a taper angle of 40 to 70 degrees and covering an end of the hole injection layer (105), the concavely curved parts being arranged in the linear region (11), the linear banks (107) being made of fluorine-containing resin; and  
 applying an ink containing an organic light emitting material to the linear region (11) to form a linear organic light emitting layer (109) which is in contact with a forward-tapered surface of the linear bank (107), wherein  
 the hole injection layer (105) is made of a metal oxide, and  
 the tilt angle (105a) between the plane of the substrate and the tangent line (105l) at an edge (105e) of the concavely curved hole injection layer (105) is 20 to 50 degrees as measured when the concavely curved hole injection layer (105) is seen from a cross section which is perpendicular to the direction of the linear banks (107).

5. The organic electroluminescence display panel according to claim 1, wherein the tilt angle is 40 to 50 degrees.

### Patentansprüche

1. Organischer Elektroluminiszenz-Anzeigebildschirm, der umfasst:

ein Substrat (101) mit konkav gekrümmten Teil-

len darauf;

lineare Wände (107), die auf dem Substrat (101) angeordnet sind und einen linearen Bereich (11) auf dem Substrat (101) bilden, wobei die linearen Wände aus fluorhaltigem Harz bestehen und eine sich nach vorn verjüngende Form mit einem Verjüngungswinkel von 40° bis 70° haben; und  
wenigstens zwei organische Elektrolumineszenz-Elemente (10), die in dem linearen Bereich (11) in einer Reihe ausgerichtet sind, wobei jedes organische Elektrolumineszenz-Element (10) enthält:

eine Anode (103), die auf dem konkav gekrümmten Teil angeordnet ist;  
eine Lochinjektions-Schicht (105), die aus einem Metalloxid besteht und auf der Anode (103) angeordnet ist;  
eine organische Lichtemissions-Schicht (109), die auf der Lochinjektions-Schicht (105) angeordnet ist und in Kontakt mit einer sich nach vorn verjüngenden Fläche der linearen Wand (107) ist; sowie  
eine Kathode (111), die auf der organischen Lichtemissions-Schicht (109) angeordnet ist;

wobei die Lochinjektions-Schicht (105) konkav gekrümmt ist,  
die Lochinjektions-Schicht (105) teilweise unter den Wänden (107) angeordnet ist, so dass ein Ende der Lochinjektions-Schicht (105) von den Wänden (107) abgedeckt wird,  
der Neigungswinkel (105a) zwischen der Ebene des Substrats und der Tangenten-Linie (1051) an einer Kante (105e) der konkav gekrümmten Lochinjektions-Schicht (105), gemessen bei Sicht auf die konkav gekrümmte Lochinjektions-Schicht (105) von einem Querschnitt aus, der senkrecht zur Richtung der linearen Wände (107) ist, 20° bis 50° beträgt, und  
die organische Lichtemissions-Schicht (109) im Inneren des linearen Bereiches (11) ausgebildet ist.

2. Organischer Elektrolumineszenz-Anzeigebildschirm nach Anspruch 1, wobei die konkav gekrümmte Lochinjektions-Schicht (105) eine Tiefe (105d) von 50 bis 300 nm hat.
3. Organischer Elektrolumineszenz-Anzeigebildschirm nach Anspruch 1, wobei das Metalloxid Wolframoxid, Molybdänoxid, Vanadiumoxid oder eine Kombination daraus ist.
4. Verfahren zum Herstellen eines organischen Elektrolumineszenz-Anzeigebildschirms, das die folgen-

den Schritte umfasst:

Bereitstellen eines Substrats (101);  
Ausbilden wenigstens zweier konkav gekrümmter Teile auf dem Substrat (101);  
Ausbilden einer Anode (103) auf den konkav gekrümmten Teilen;  
Ausbilden einer Lochinjektions-Schicht (105) auf der Anode (103);  
Ausbilden linearer Wände (107), die einen linearen Bereich (11) auf dem Substrat (101) bilden, wobei die linearen Wände (107) eine sich nach vorn verjüngende Form mit einem Verjüngungswinkel von 40° bis 70° haben und ein Ende der Lochinjektions-Schicht (105) abdecken, die konkav gekrümmten Teil in dem linearen Bereich (11) angeordnet sind und die linearen Wände (107) aus fluorhaltigem Harz bestehen; sowie  
Aufbringen einer Tinte, die ein organisches Lichtemissionsmaterial enthält, auf den linearen Bereich (11), um eine lineare organische Lichtemissions-Schicht (109) auszubilden, die in Kontakt mit einer sich nach vorn verjüngenden Fläche der linearen Wand (107) ist, wobei die Lochinjektions-Schicht (105) aus einem Metalloxid besteht, und  
der Neigungswinkel (105a) zwischen der Ebene des Substrats und der Tangenten-Linie (1051) an einer Kante (105e) der konkav gekrümmten Lochinjektions-Schicht (105), gemessen bei Sicht auf die konkav gekrümmte Lochinjektions-Schicht (105) von einem Querschnitt aus, der senkrecht zur Richtung der linearen Wände (107) ist, 20° bis 50° beträgt.

5. Organischer Elektrolumineszenz-Anzeigebildschirm nach Anspruch 1, wobei der Neigungswinkel 40° bis 50° beträgt.

#### Revendications

1. Panneau d'affichage à électroluminescence organique, comprenant :

un substrat (101) comportant des parties à courbure concave ;  
des bancs linéaires (107) placés sur le substrat (101) et définissant une zone linéaire (11) sur le substrat (101), les bancs linéaires (107) étant constitués d'une résine contenant du fluor et ayant une forme biseautée vers l'avant avec un angle de biseau de 40 à 70 degrés ; et  
au moins deux éléments à électroluminescence organique (10) alignés sur une ligne dans la zone linéaire (11), chaque élément à électroluminescence organique (10) comprenant :

- une anode (103) placée sur la partie à courbure concave ;  
 une couche d'injection de trous (105) constituée d'un oxyde métallique et placée sur l'anode (103) ;  
 une couche d'émission lumineuse organique (109) placée sur la couche d'injection de trous (105) et en contact avec une surface biseautée vers l'avant du banc linéaire (107) ; et  
 une cathode (111) placée sur la couche d'émission lumineuse organique (109) ;
- dans lequel  
 la couche d'injection de trous (105) présente une courbure concave,  
 la couche d'injection de trous (105) est agencée partiellement sous les bancs (107) de telle sorte qu'une extrémité de la couche d'injection de trous (105) est recouverte par les bancs (107),  
 l'angle d'inclinaison (105a) entre le plan du substrat et la ligne tangente (1051) à un bord (105e) de la couche d'injection de trous à courbure concave (105) est compris entre 20 et 50 degrés tel que mesuré lorsque la couche d'injection de trous à courbure concave (105) est vue depuis une section transversale perpendiculaire à la direction des bancs linéaires (107), et la couche d'émission lumineuse organique (109) est formée à l'intérieur de la zone linéaire (11).
2. Panneau d'affichage à électroluminescence organique selon la revendication 1, dans lequel la couche d'injection de trous à courbure concave (105) présente une profondeur (105d) de 50 à 300 nanomètres.
3. Panneau d'affichage à électroluminescence organique selon la revendication 1, dans lequel l'oxyde métallique est de l'oxyde de tungstène, de l'oxyde de molybdène, de l'oxyde de vanadium ou une combinaison de ceux-ci.
4. Procédé de fabrication d'un panneau d'affichage à électroluminescence organique comprenant les étapes suivantes :
- fourniture d'un substrat (101) ;  
 formation d'au moins deux parties à courbure concave sur le substrat (101) ;  
 formation d'une anode (103) sur les parties à courbure concave ;  
 formation d'une couche d'injection de trous (105) sur l'anode (103) ;  
 formation de bancs linéaires (107) définissant une zone linéaire (11) sur le substrat (101), les bancs linéaires (107) ayant une forme biseautée

vers l'avant avec un angle de biseau de 40 à 70 degrés et recouvrant une extrémité de la couche d'injection de trous (105), les parties à courbure concave étant agencées dans la zone linéaire (11), les bancs linéaires (107) étant constitués d'une résine contenant du fluor ; et application d'une encre contenant un matériau électroluminescent organique sur la zone linéaire (11) pour former une couche d'émission lumineuse organique linéaire (109) qui est en contact avec une surface biseautée vers l'avant du banc linéaire (107), dans lequel la couche d'injection de trous (105) est constituée d'un oxyde métallique, et l'angle d'inclinaison (105a) entre le plan du substrat et la ligne tangente (1051) à un bord (105e) de la couche d'injection de trous à courbure concave (105) est compris entre 20 et 50 degrés tel que mesuré lorsque la couche d'injection de trous à courbure concave (105) est vue depuis une section transversale perpendiculaire à la direction des bancs linéaires (107).

5. Panneau d'affichage à électroluminescence organique selon la revendication 1, dans lequel l'angle d'inclinaison est compris entre 40 et 50 degrés.

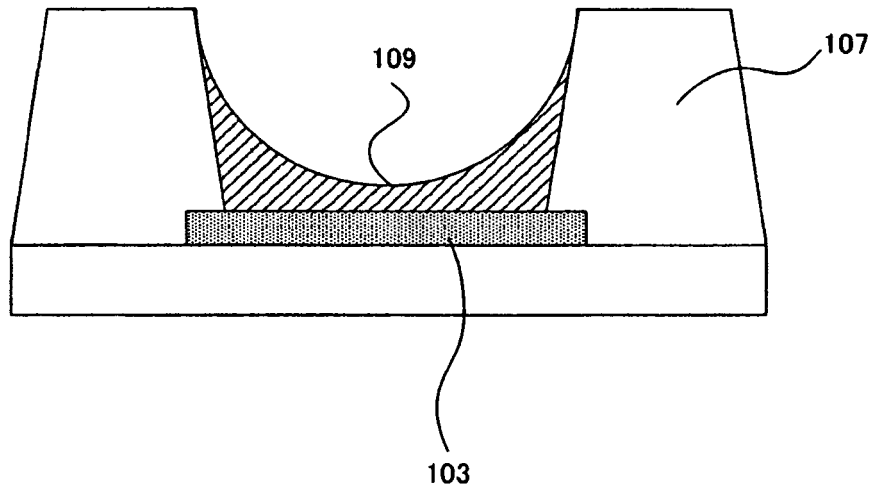

FIG. 1

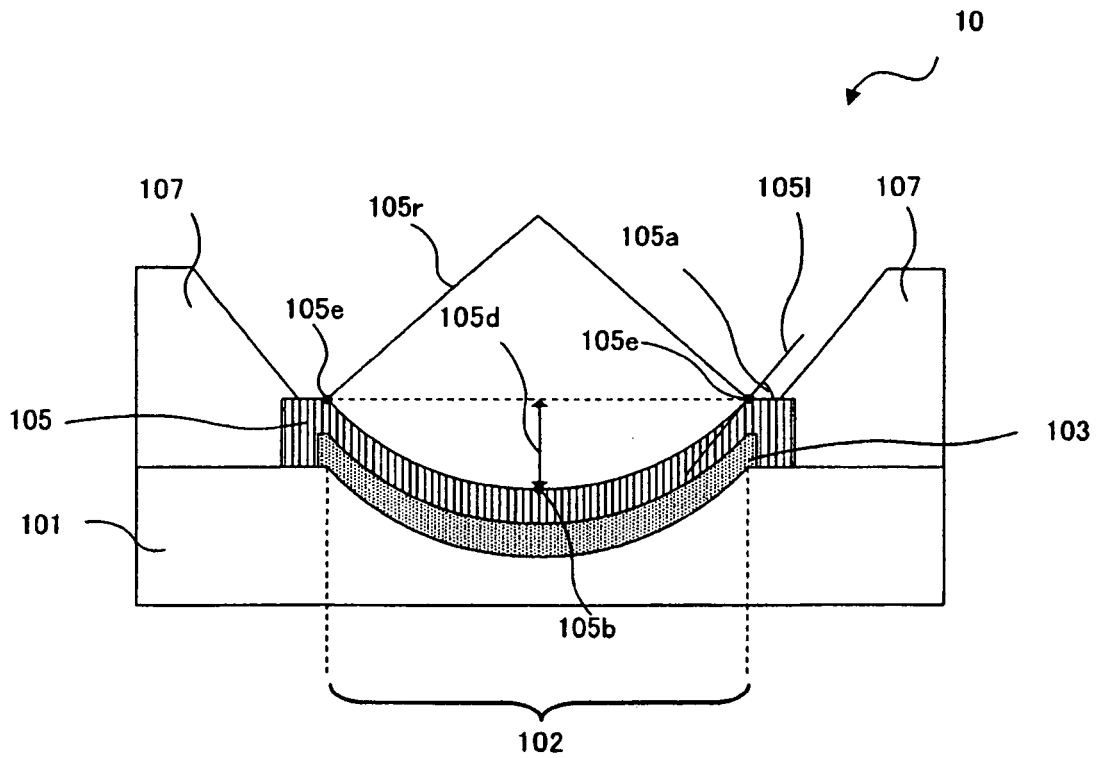

FIG. 2

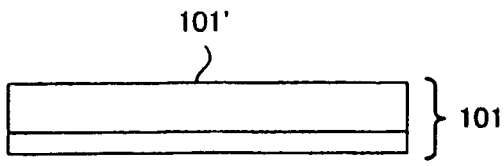

FIG. 3A

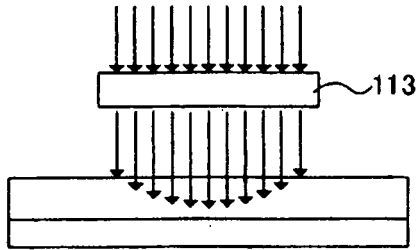

FIG. 3B

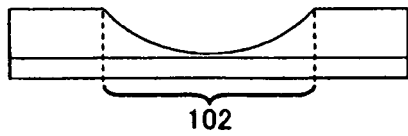

FIG. 3C

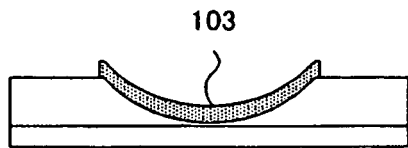

FIG. 3D

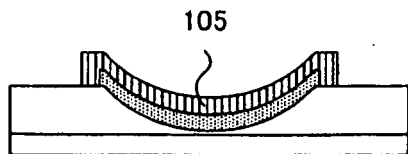

FIG. 3E

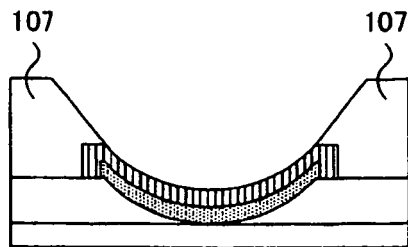

FIG. 3F

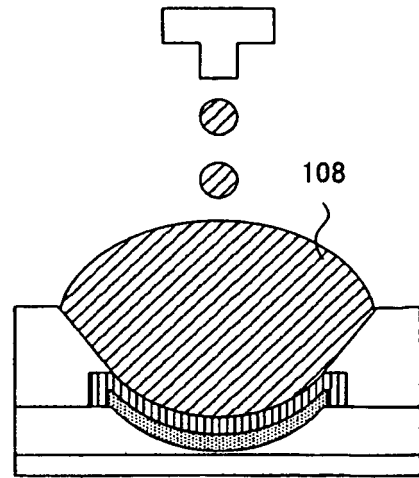

FIG. 3G

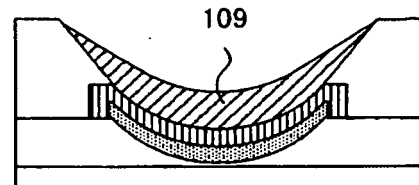

FIG. 3H

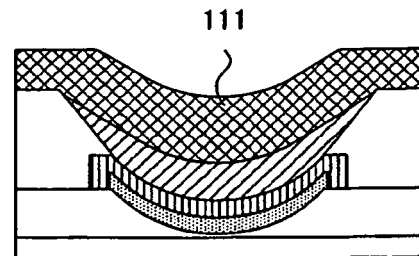

FIG. 3I

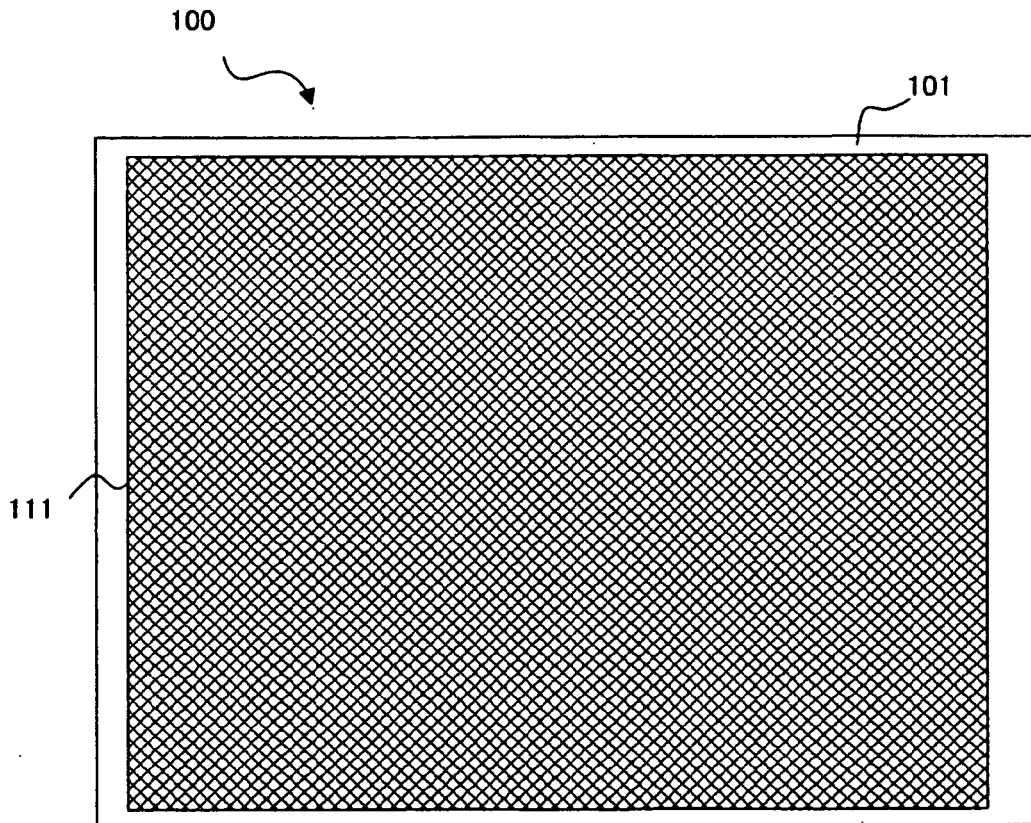

FIG. 4

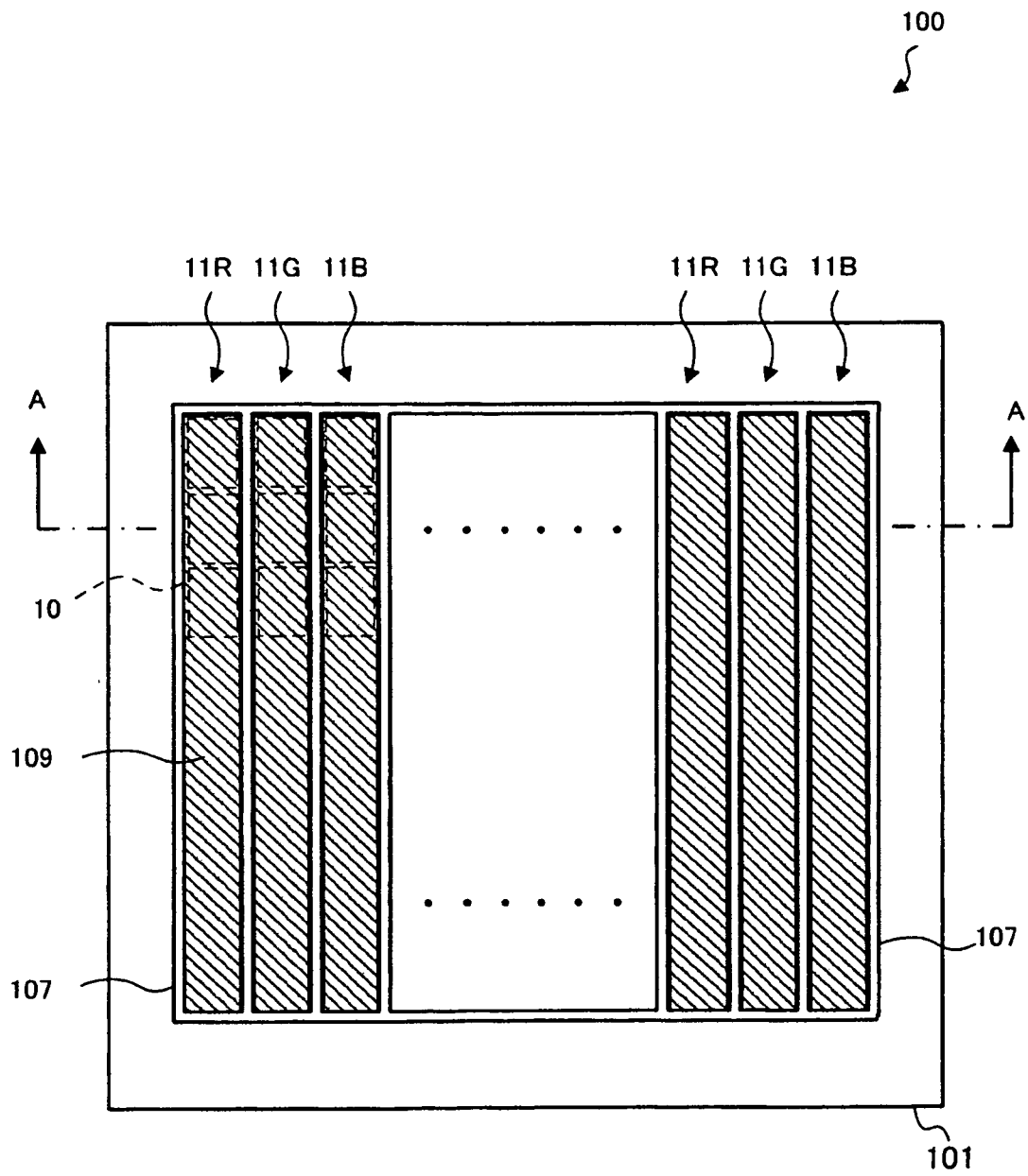

FIG. 5

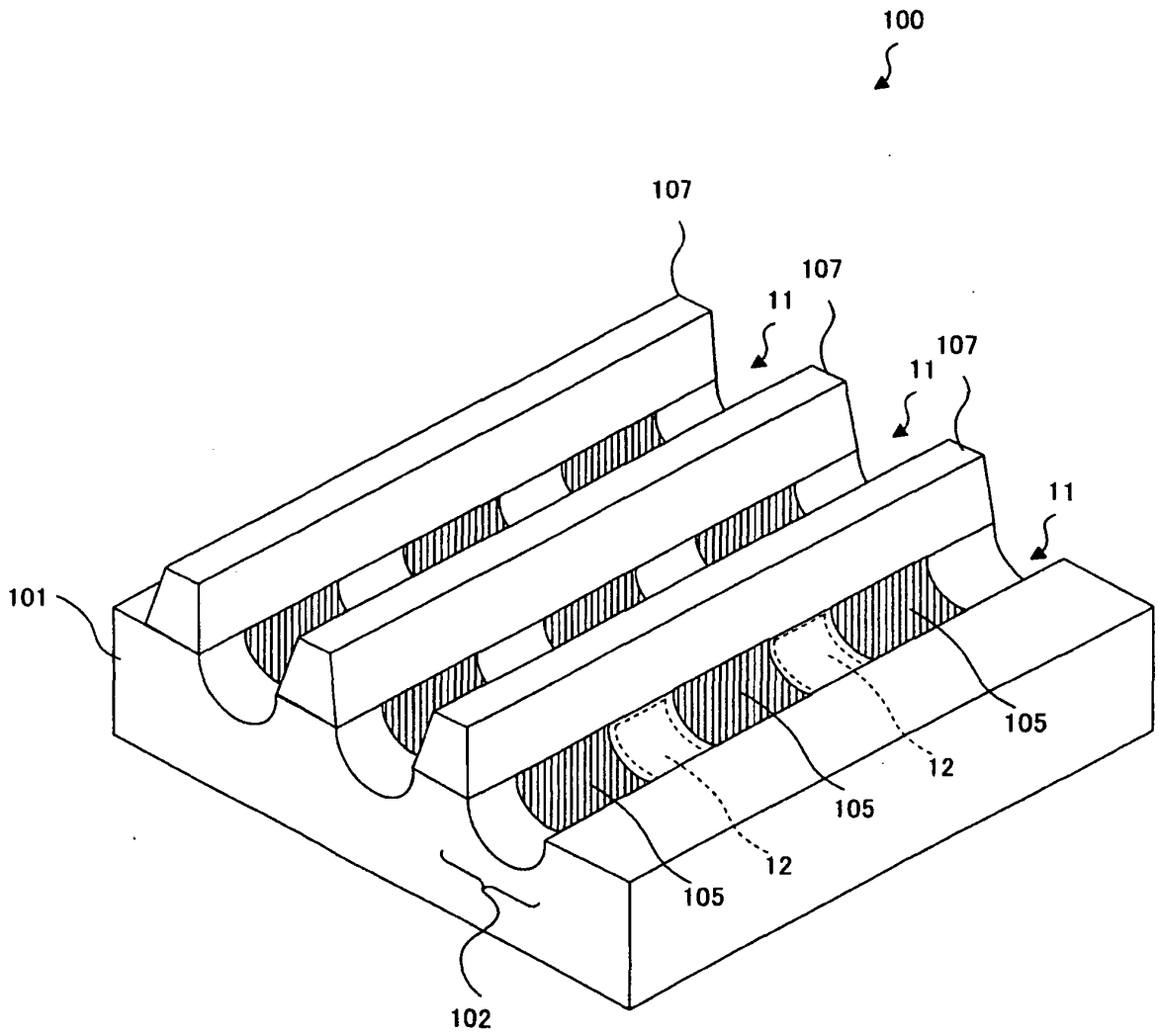

FIG. 6

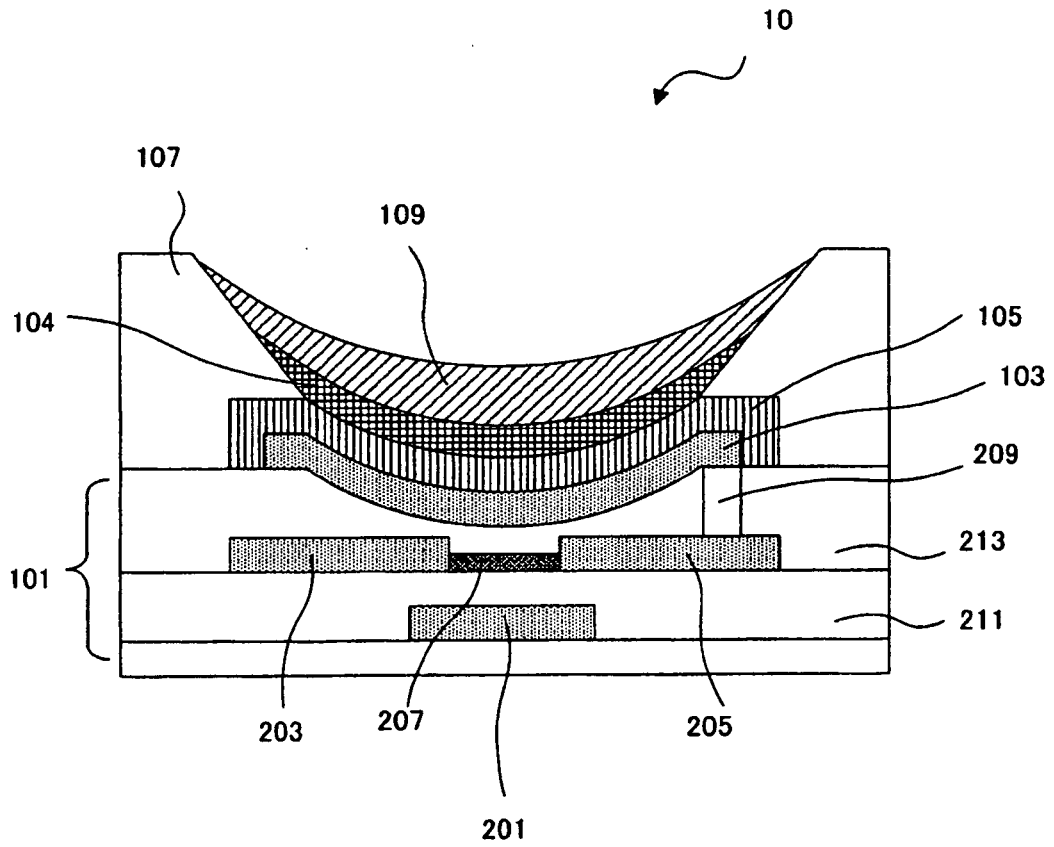

FIG. 7

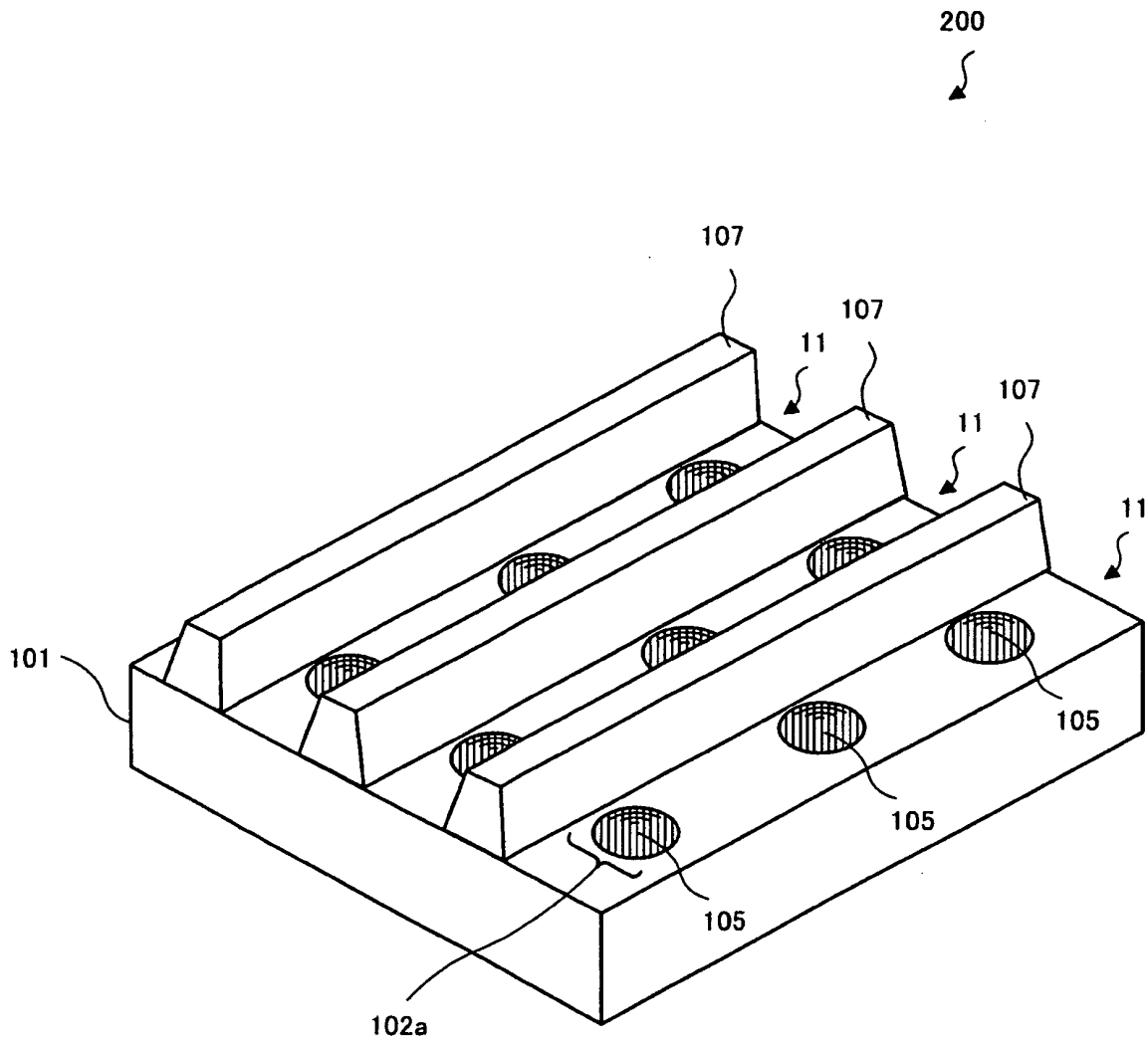

FIG. 8

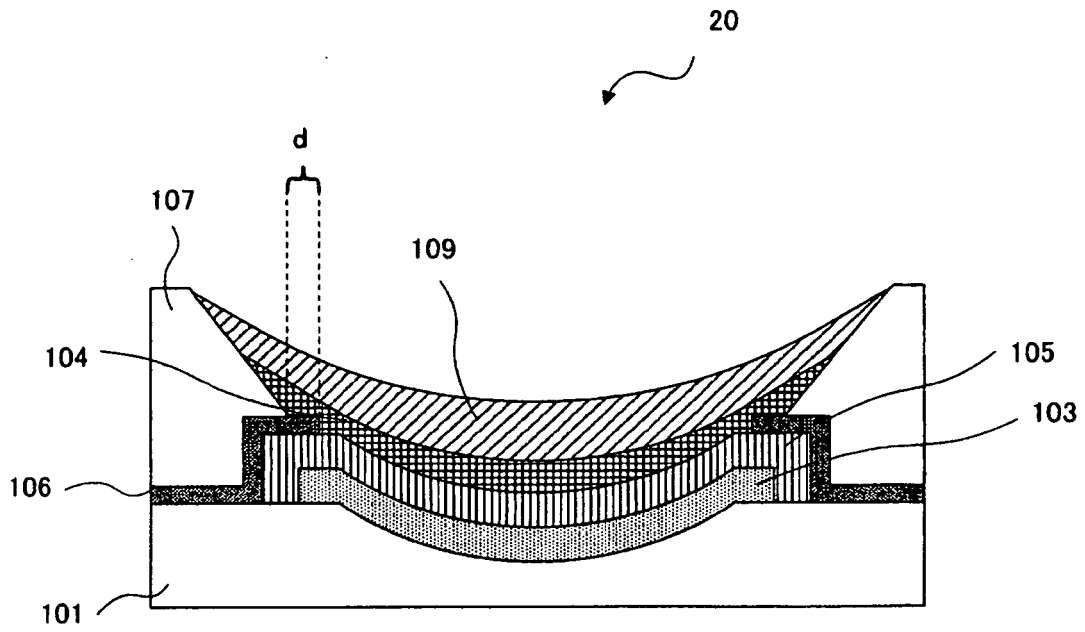

FIG. 9

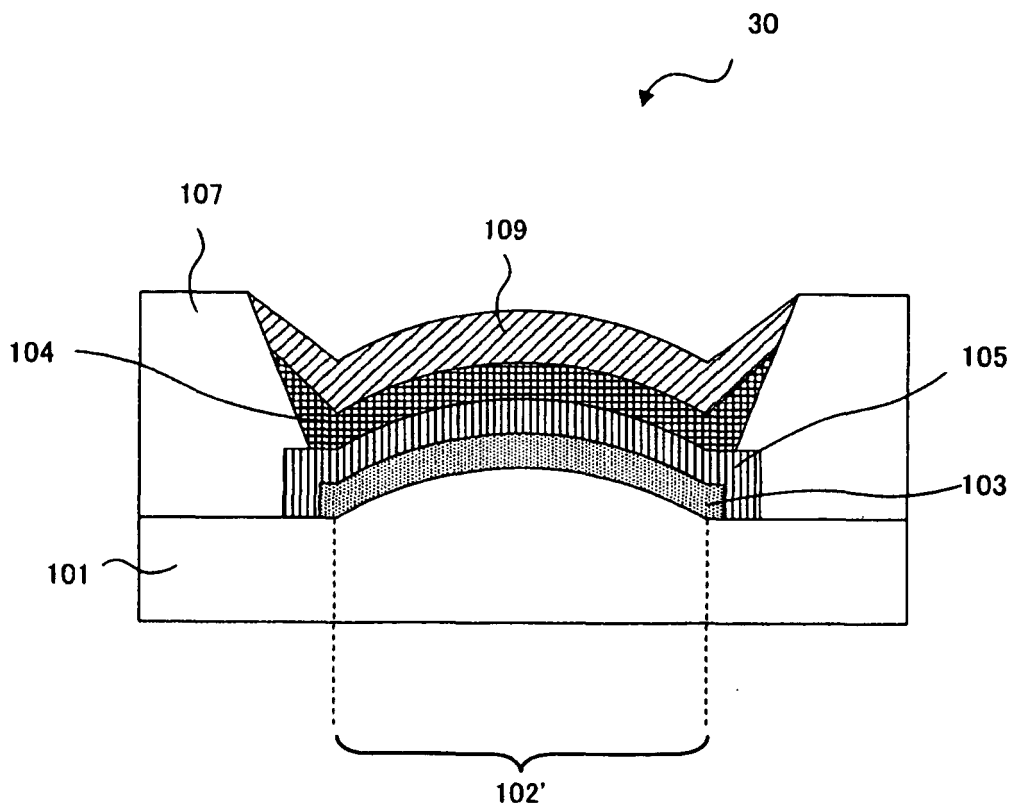

FIG. 10

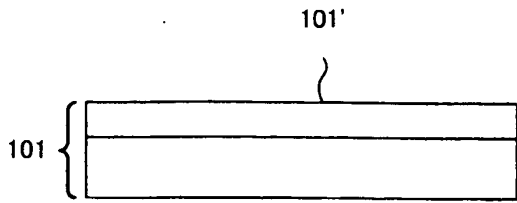

FIG. 11A

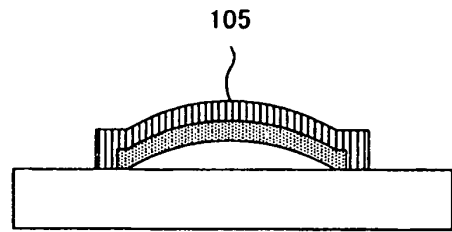

FIG. 11E

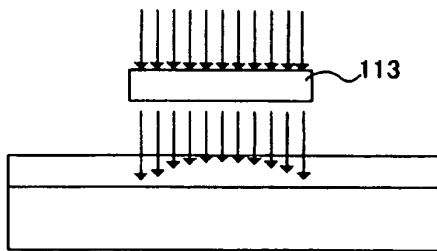

FIG. 11B

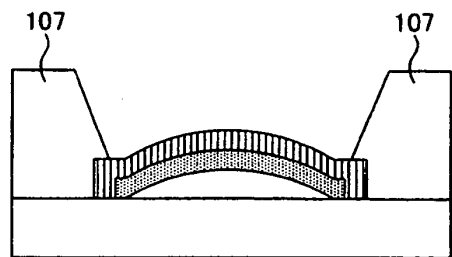

FIG. 11F



FIG. 11C

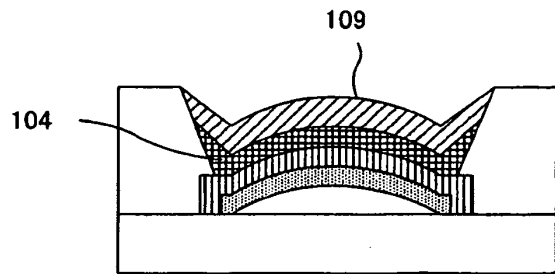

FIG. 11G

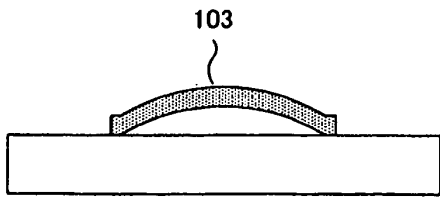

FIG. 11D

**REFERENCES CITED IN THE DESCRIPTION**

*This list of references cited by the applicant is for the reader's convenience only. It does not form part of the European patent document. Even though great care has been taken in compiling the references, errors or omissions cannot be excluded and the EPO disclaims all liability in this regard.*

**Patent documents cited in the description**

- GB 2416066 A [0015]
- JP 2007220656 A [0016]
- US 2008024402 A1 [0017]
- JP 2005331665 B [0018]
- JP 2006252988 A [0018]
- WO 05107327 A [0018]
- US 20080024402 A [0018]
- JP 2005174914 A [0018]
- JP 2007505465 A [0018]
- US 20050029538 A [0018]
- JP 2004335470 A [0018]
- US 20040222740 A [0018]
- JP 2004127575 A [0018]
- JP 2005174717 A [0018]
- JP HEI10223368 B [0018]
- JP 2003264084 A [0018]
- US 20050062412 A [0018]
- JP HEI10208875 B [0018]
- JP HEI547470 B [0018]
- JP 2005222935 A [0018]
- US 20050174041 A [0018]

专利名称(译)	有机EL显示板		
公开(公告)号	<a href="#">EP2270896B1</a>	公开(公告)日	2014-12-24
申请号	EP2009700056	申请日	2009-01-30
[标]申请(专利权)人(译)	松下电器产业株式会社		
申请(专利权)人(译)	松下电器产业株式会社		
当前申请(专利权)人(译)	松下电器产业株式会社		
[标]发明人	YOSHIDA HIDEHIRO OKUMOTO KENJI YAMAMURO KEISEI		
发明人	YOSHIDA, HIDEHIRO OKUMOTO, KENJI YAMAMURO, KEISEI		
IPC分类号	H01L27/32		
CPC分类号	H01L51/5088 H01L27/3246 H01L27/3258 H01L27/3283 H01L51/0003 H01L51/5209 H01L51/5262		
代理机构(译)	GRÜNECKER , KINKELDEY , STOCKMAIR & SCHWANHÄUSSER		
优先权	2008047043 2008-02-28 JP		
其他公开文献	EP2270896A4 EP2270896A1		
外部链接	<a href="#">Espacenet</a>		

摘要(译)

有机EL显示板技术领域本发明涉及具有均匀膜厚的有机发光层的有机EL显示板。本发明的有机EL显示屏包括：基板；线性堤岸放置在基板上并在基板上限定线性区域；至少两个有机EL元件在每个线性区域中排成一排，并且每个有机EL元件包括：放置在基板上的阳极；空穴注入层，由金属氧化物形成并置于阳极上；有机发光层置于空穴注入层上；阴极置于有机发光层上。空穴注入层凹入弯曲或凸出弯曲，空穴注入层部分位于堤岸下方；通过在线性区域中施加有机发光材料来形成有机发光层。

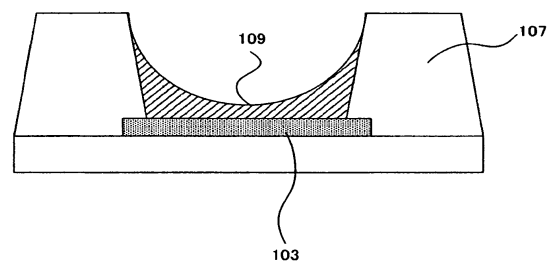

FIG. 1