

(19)



(11)

EP 2 226 845 A3

(12)

EUROPEAN PATENT APPLICATION

(88) Date of publication A3:
02.04.2014 Bulletin 2014/14

(51) Int Cl.:
H01L 27/32^(2006.01)

(43) Date of publication A2:
08.09.2010 Bulletin 2010/36

(21) Application number: **10154502.8**

(22) Date of filing: **24.02.2010**

(84) Designated Contracting States:
AT BE BG CH CY CZ DE DK EE ES FI FR GB GR HR HU IE IS IT LI LT LU LV MC MK MT NL NO PL PT RO SE SI SK SM TR
Designated Extension States:
AL BA RS

(30) Priority: **03.03.2009 KR 20090018200**

(71) Applicant: **Samsung Display Co., Ltd. Yongin-City, Gyeonggi-Do, 446-711 (KR)**

(72) Inventors:

- **Park, Byoung-Keon**
446-711, Gyeonggi-Do (KR)
- **Yang, Tae-Hoon**
446-711, Gyeonggi-Do (KR)
- **Seo, Jin-Wook**
446-711, Gyeonggi-Do (KR)
- **Jo, Soo-Beom**
446-711, Gyeonggi-Do (KR)

- **Lee, Dong-Hyun**
446-711, Gyeonggi-Do (KR)
- **Lee, Kil-Won**
446-711, Gyeonggi-Do (KR)
- **Lisachenko, Maxim**
446-711, Gyeonggi-Do (KR)
- **Chung, Yun-Mo**
446-711, Gyeonggi-Do (KR)
- **Choi, Bo-Kyung**
446-711, Gyeonggi-Do (KR)
- **Park, Jong-Ryuk**
446-711, Gyeonggi-Do (KR)
- **Lee, Ki-Yong**
446-711, Gyeonggi-Do (KR)

(74) Representative: **Walaski, Jan Filip**
Venner Shipley LLP
200 Aldersgate
London
EC1A 4HD (GB)

(54) **Organic light emitting diode display device and method of fabricating the same**

(57) An organic light emitting diode (OLED) display device and a method of fabricating the same are provided. The OLED display device includes a substrate having a thin film transistor region and a capacitor region, a buffer layer disposed on the substrate, a gate insulating layer disposed on the substrate, a lower capacitor electrode disposed on the gate insulating layer in the capacitor region, an interlayer insulating layer disposed on the substrate, and an upper capacitor electrode disposed on the interlayer insulating layer and facing the lower capacitor

electrode, wherein regions of each of the buffer layer, the gate insulating layer, the interlayer insulating layer, the lower capacitor electrode, and the upper capacitor electrode have surfaces in which protrusions having the same shape as grain boundaries of the semiconductor layer are formed. The resultant capacitor has an increased surface area, and therefore, an increased capacitance.

EP 2 226 845 A3

FIG. 1G

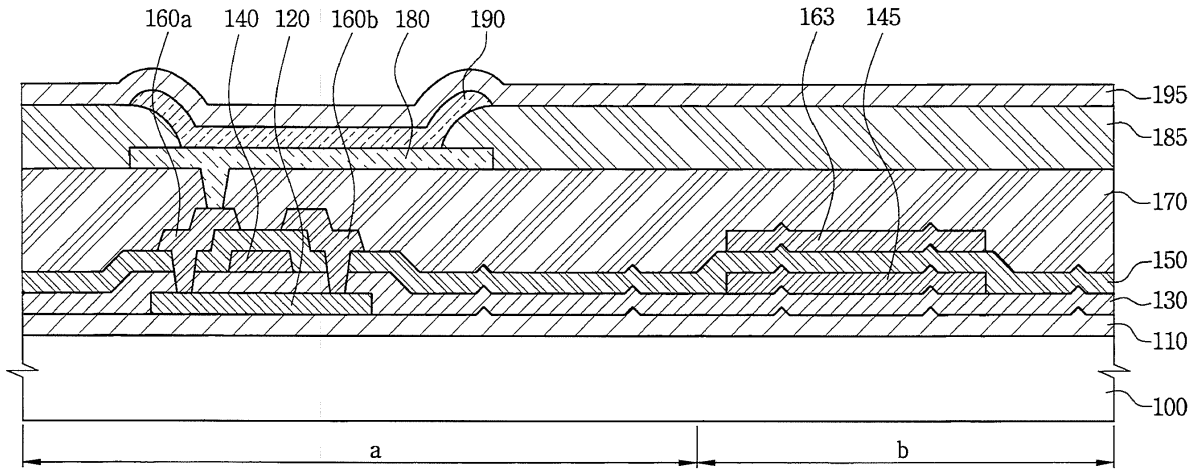



EUROPEAN SEARCH REPORT

Application Number
EP 10 15 4502

DOCUMENTS CONSIDERED TO BE RELEVANT				
Category	Citation of document with indication, where appropriate, of relevant passages	Relevant to claim	CLASSIFICATION OF THE APPLICATION (IPC)	
X	KR 2004 0035409 A (SAMSUNG SDI CO LTD) 29 April 2004 (2004-04-29)	1-6,8-15	INV. H01L27/32	
Y	* abstract; figure 5 *	7		
X	JP H07 13196 A (TOSHIBA CORP) 17 January 1995 (1995-01-17)	1-6,8-15		
Y	* abstract; figure 1 *	7		
X	US 2004/004597 A1 (KUNG NIEN-HUI [TW] ET AL) 8 January 2004 (2004-01-08)	1-6,8-15		
Y	* paragraph [0018] - paragraph [0026]; figures 4-6 *	7		
X	JP H06 67203 A (SEIKO EPSON CORP) 11 March 1994 (1994-03-11)	1,11		
X	JP 2001 337348 A (TOSHIBA CORP) 7 December 2001 (2001-12-07)	1,11		
Y	EP 0 763 765 A1 (CANON KK [JP]) 19 March 1997 (1997-03-19)	7		TECHNICAL FIELDS SEARCHED (IPC)
	* page 8, line 35 - page 9, line 5; figure 4 *			H01L G02F
The present search report has been drawn up for all claims				
Place of search Munich		Date of completion of the search 24 February 2014	Examiner Bernabé Prieto, A	
CATEGORY OF CITED DOCUMENTS		T : theory or principle underlying the invention E : earlier patent document, but published on, or after the filing date D : document cited in the application L : document cited for other reasons & : member of the same patent family, corresponding document		
X : particularly relevant if taken alone Y : particularly relevant if combined with another document of the same category A : technological background O : non-written disclosure P : intermediate document				

1
EPO FORM 1503 03.82 (P04C01)

ANNEX TO THE EUROPEAN SEARCH REPORT
ON EUROPEAN PATENT APPLICATION NO.

EP 10 15 4502

This annex lists the patent family members relating to the patent documents cited in the above-mentioned European search report. The members are as contained in the European Patent Office EDP file on
The European Patent Office is in no way liable for these particulars which are merely given for the purpose of information.

24-02-2014

Patent document cited in search report	Publication date	Patent family member(s)	Publication date
KR 20040035409 A	29-04-2004	NONE	
JP H0713196 A	17-01-1995	NONE	
US 2004004597 A1	08-01-2004	JP 2004040075 A TW 536716 B US 2004004597 A1	05-02-2004 11-06-2003 08-01-2004
JP H0667203 A	11-03-1994	JP 3139154 B2 JP H0667203 A	26-02-2001 11-03-1994
JP 2001337348 A	07-12-2001	NONE	
EP 0763765 A1	19-03-1997	DE 69614793 D1 DE 69614793 T2 EP 0763765 A1 JP 3143591 B2 JP H09138397 A TW 477906 B US 5708486 A	04-10-2001 02-05-2002 19-03-1997 07-03-2001 27-05-1997 01-03-2002 13-01-1998

EPO FORM P0459

For more details about this annex : see Official Journal of the European Patent Office, No. 12/82

专利名称(译)	有机发光二极管显示装置及其制造方法		
公开(公告)号	EP2226845A3	公开(公告)日	2014-04-02
申请号	EP2010154502	申请日	2010-02-24
[标]申请(专利权)人(译)	三星显示有限公司		
申请(专利权)人(译)	三星移动显示器有限公司.		
当前申请(专利权)人(译)	三星DISPLAY CO. , LTD.		
[标]发明人	PARK BYOUNG KEON YANG TAE HOON SEO JIN WOOK JO SOO BEOM LEE DONG HYUN LEE KIL WON LISACHENKO MAXIM CHUNG YUN MO CHOI BO KYUNG PARK JONG RYUK LEE KI YONG		
发明人	PARK, BYOUNG-KEON YANG, TAE-HOON SEO, JIN-WOOK JO, SOO-BEOM LEE, DONG-HYUN LEE, KIL-WON LISACHENKO, MAXIM CHUNG, YUN-MO CHOI, BO-KYUNG PARK, JONG-RYUK LEE, KI-YONG		
IPC分类号	H01L27/32		
CPC分类号	H01L27/3265 H01L2227/323 H01L51/52		
优先权	1020090018200 2009-03-03 KR		
其他公开文献	EP2226845A2 EP2226845B1		
外部链接	Espacenet		

摘要(译)

提供了一种有机发光二极管 (OLED) 显示装置及其制造方法。 OLED显示装置包括具有薄膜晶体管区域和电容器区域的基板，设置在基板上的缓冲层，设置在基板上的栅极绝缘层，设置在电容器区域中的栅极绝缘层上的下电容器电极，层间绝缘层设置于基板上，上层电容器电极设置于层间绝缘层上且面向下层电容器电极，其中缓冲层，栅极绝缘层，层间绝缘层，下电容器电极各自的区域上电容器电极具有这样的表面，其中形成具有与半导体层的晶界相同形状的突起。所得到的电容器具有增大的表面积，因此增加了电容。

FIG. 1G

