

(19)



(11)

**EP 2 226 845 A2**

(12)

**EUROPEAN PATENT APPLICATION**

(43) Date of publication:  
**08.09.2010 Bulletin 2010/36**

(51) Int Cl.:  
**H01L 27/32<sup>(2006.01)</sup>**

(21) Application number: **10154502.8**

(22) Date of filing: **24.02.2010**

(84) Designated Contracting States:  
**AT BE BG CH CY CZ DE DK EE ES FI FR GB GR  
 HR HU IE IS IT LI LT LU LV MC MK MT NL NO PL  
 PT RO SE SI SK SM TR**  
 Designated Extension States:  
**AL BA RS**

- **Lee, Dong-Hyun**  
446-711, Gyunggi-Do (KR)
- **Lee, Kil-Won**  
446-711, Gyunggi-Do (KR)
- **Lisachenko, Maxim**  
446-711, Gyunggi-Do (KR)
- **Chung, Yun-Mo**  
446-711, Gyunggi-Do (KR)
- **Choi, Bo-Kyung**  
446-711, Gyunggi-Do (KR)
- **Park, Jong-Ryuk**  
446-711, Gyunggi-Do (KR)
- **Lee, Ki-Yong**  
446-711, Gyunggi-Do (KR)

(30) Priority: **03.03.2009 KR 20090018200**

(71) Applicant: **Samsung Mobile Display Co., Ltd.**  
**Yongin-city, Gyunggi-do 446-711 (KR)**

- (72) Inventors:
- **Park, Byoung-Keon**  
446-711, Gyunggi-Do (KR)
  - **Yang, Tae-Hoon**  
446-711, Gyunggi-Do (KR)
  - **Seo, Jin-Wook**  
446-711, Gyunggi-Do (KR)
  - **Jo, Soo-Beom**  
446-711, Gyunggi-Do (KR)

(74) Representative: **Walaski, Jan Filip**  
**Venner Shipley LLP**  
**20 Little Britain**  
**London**  
**EC1A 7DH (GB)**

**(54) Organic light emitting diode display device and method of fabricating the same**

(57) An organic light emitting diode (OLED) display device and a method of fabricating the same are provided. The OLED display device includes a substrate having a thin film transistor region and a capacitor region, a buffer layer disposed on the substrate, a gate insulating layer disposed on the substrate, a lower capacitor electrode disposed on the gate insulating layer in the capacitor region, an interlayer insulating layer disposed on the substrate, and an upper capacitor electrode disposed on the

interlayer insulating layer and facing the lower capacitor electrode, wherein regions of each of the buffer layer, the gate insulating layer, the interlayer insulating layer, the lower capacitor electrode, and the upper capacitor electrode have surfaces in which protrusions having the same shape as grain boundaries of the semiconductor layer are formed. The resultant capacitor has an increased surface area, and therefore, an increased capacitance.

FIG. 1G

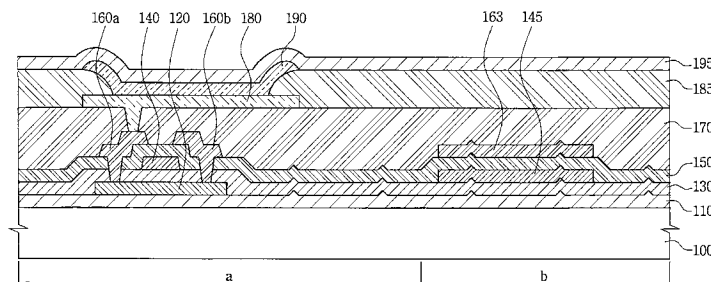

**EP 2 226 845 A2**

## Description

**[0001]** The present invention relates to an organic light emitting diode (OLED) display device and a method of fabricating the same, and more particularly, to an OLED display device including a capacitor whose capacitance is increased using a method of fabricating a polysilicon layer using a metal catalyst and a method of fabricating the same.

**[0002]** In general, polysilicon is widely used as a semiconductor layer of a thin film transistor due to its high field effect mobility and applicability to high-speed operating circuits and complementary metal-oxide-semiconductor (CMOS) circuits. The thin film transistors having a polysilicon layer are generally used as active elements of active matrix liquid crystal displays (AMLCDs), and switching elements and driving elements of organic light emitting diodes (OLEDs).

**[0003]** Here, methods of crystallizing an amorphous silicon layer into the polysilicon layer used for a thin film transistor include a solid phase crystallization (SPC) method, an excimer laser crystallization (ELC) method, a metal induced crystallization (MIC) method, and a metal induced lateral crystallization (MILC) method. In the SPC method, an amorphous silicon layer is annealed at a temperature of about 700°C or less, i.e., a transition temperature of a glass substrate of a display device for several hours to several tens of hours. In the ELC method, an excimer laser is irradiated on an amorphous silicon layer to locally heat the irradiated portion to a high temperature for a very short time period, so that the amorphous silicon layer is crystallized. In the MIC method, metals such as nickel, palladium, gold, aluminum, etc., are placed in contact with or injected into an amorphous silicon layer, so that the amorphous silicon layer is changed into a polysilicon layer, i.e., a phase change of the amorphous silicon is induced by the metal. In the MILC method, silicide, which is produced by reacting metal with silicon, is laterally and continuously diffused to sequentially induce crystallization of the amorphous silicon layer.

**[0004]** However, the SPC method requires a long time, and the annealing process is performed at a high temperature for a long time, which may deform a substrate. Also, in the ELC method, a high-priced laser device is required, and protrusions may be formed on the polycrystalline surface such that interfacial characteristics between a semiconductor layer and a gate insulating layer may deteriorate.

**[0005]** Currently, research into methods of crystallizing an amorphous silicon layer using a metal is actively progressing because crystallization can be achieved at a lower temperature and with less time than the SPC method. The methods of crystallizing an amorphous silicon layer using a metal include the MIC method, the MILC method, and a super grain silicon crystallization method.

**[0006]** Meanwhile, in an OLED, capacitors are formed, and a capacitor having a high capacitance may be advantageous to the operation of the OLED. Thus, research

into increasing the capacitance of the capacitor is required.

**[0007]** Aspects of the present invention provide an organic light emitting diode (OLED) display device in which capacitance of a capacitor is increased by increasing a surface area of the capacitor in a simple manner and a method of fabricating the same.

**[0008]** According to aspects of the present invention, an OLED display device includes: a substrate having a thin film transistor region and a capacitor region; a buffer layer disposed on the substrate; a patterned semiconductor layer disposed on the buffer layer in the thin film transistor region; a gate insulating layer disposed on the substrate to cover the patterned semiconductor layer; a gate electrode disposed on the gate insulating layer and facing a predetermined region of the patterned semiconductor layer; a lower capacitor electrode disposed on the gate insulating layer in the capacitor region; an interlayer insulating layer disposed on the substrate to cover the gate electrode and the lower capacitor electrode; source and drain electrodes disposed on the interlayer insulating layer and electrically connected to the patterned semiconductor layer, and an upper capacitor electrode disposed on the interlayer insulating layer and facing the lower capacitor electrode; a first electrode disposed on the interlayer insulating layer and electrically connected to one of the source and drain electrodes; an organic layer including a light emitting layer, the organic layer being disposed on the first electrode; and a second electrode disposed on the organic layer, wherein regions of each of the buffer layer, the gate insulating layer, the interlayer insulating layer, the lower capacitor electrode, and the upper capacitor electrode that are disposed in the capacitor region of the substrate have surfaces in which protrusions are formed, the protrusions following the shape of grain boundaries of the patterned semiconductor layer.

**[0009]** According to aspects of the present invention, a method of fabricating an organic light emitting diode (OLED) display device includes: forming a substrate having a thin film transistor region and a capacitor region; forming a buffer layer on the substrate; forming an amorphous silicon layer on the buffer layer; forming a metal catalyst layer on the amorphous silicon layer; annealing the substrate to crystallize the amorphous silicon layer into a polysilicon layer; removing the metal catalyst layer; forming protrusions in the buffer layer while patterning the polysilicon layer to form a semiconductor layer in the thin film transistor region; forming a gate insulating layer on the substrate to cover the semiconductor layer; forming a gate electrode on the gate insulating layer and facing a predetermined region of the semiconductor layer; forming a lower capacitor electrode on the gate insulating layer in the capacitor region; forming an interlayer insulating layer on the substrate to cover the gate electrode and the lower capacitor electrode; forming source and drain electrodes on the interlayer insulating layer which are electrically connected to the semiconductor layer;

forming an upper capacitor electrode on the interlayer insulating layer and facing the lower electrode; forming a first electrode on the interlayer insulating layer which is electrically connected to one of the source and drain regions of the semiconductor layer; forming an organic layer including a light emitting layer on the first electrode; and forming a second electrode on the organic layer.

**[0010]** According to aspects of the present invention, an OLED display device includes: a substrate having a thin film transistor region and a capacitor region; a buffer layer disposed on the substrate, the buffer layer having protrusions in the capacitor region that extend therefrom away from the substrate; and a capacitor disposed on the buffer layer in the capacitor region, wherein the capacitor follows the shape of the protrusions of the buffer layer.

**[0011]** According to aspects of the present invention, a method of manufacturing an organic light emitting diode (OLED) display device includes: forming a substrate having a thin film transistor region and a capacitor region; forming a buffer layer on the substrate; forming an amorphous silicon layer on the buffer layer; crystallizing the amorphous silicon layer to form a polysilicon layer having grain boundaries; forming protrusions in portions of the buffer layer adjacent to the grain boundaries of the polysilicon layer while patterning the polysilicon layer to form a semiconductor layer, the semiconductor layer being disposed in the thin film transistor region; forming a lower capacitor electrode on the gate insulating layer in the capacitor region, the lower capacitor electrode having protrusions corresponding to the protrusions of the buffer layer; forming an interlayer insulating layer on the substrate to cover at least the lower capacitor electrode, the interlayer insulating layer having protrusions corresponding to the protrusions of the lower capacitor electrode; and forming an upper capacitor electrode on the interlayer insulating layer and facing the lower electrode, the upper capacitor electrode having protrusions corresponding to the protrusions of the interlayer insulating layer.

**[0012]** According to aspects of the present invention: a method of manufacturing an organic light emitting diode (OLED) display device includes: forming a buffer layer on a substrate; forming protrusions in portions of the buffer layer; forming a lower capacitor electrode on the gate insulating layer, the lower capacitor electrode having protrusions corresponding to the protrusions of the buffer layer; forming an interlayer insulating layer on the substrate to cover at least the lower capacitor electrode, the interlayer insulating layer having protrusions corresponding to the protrusions of the lower capacitor electrode; and forming an upper capacitor electrode on the interlayer insulating layer and facing the lower electrode, the upper capacitor electrode having protrusions corresponding to the protrusions of the interlayer insulating layer.

**[0013]** Additional aspects and/or advantages of the invention will be set forth in part in the description which

follows and, in part, will be obvious from the description, or may be learned by practice of the invention.

**[0014]** These and/or other aspects and advantages of the invention will become apparent and more readily appreciated from the following description of the embodiments, taken in conjunction with the accompanying drawings of which:

FIGS. 1A to 1G illustrate manufacture of an organic light emitting diode (OLED) display device according to an exemplary embodiment of the present invention; and

FIG. 2 is a photograph showing a surface of a buffer layer from which a polysilicon layer is removed according to an exemplary embodiment of the present invention.

**[0015]** Reference will now be made in detail to the present embodiments of the present invention, examples of which are illustrated in the accompanying drawings, wherein like reference numerals refer to the like elements throughout. The embodiments are described below in order to explain the present invention by referring to the figures. In the drawings, the sizes and proportions of layers/regions may be exaggerated, and like reference numerals refer to like elements. It will be understood that when an element such as a layer, film, region, or substrate is referred to as being "formed on" or "disposed on" another element, it can be disposed directly on the other element, or intervening elements may also be present. In contrast, when an element is referred to as being "formed directly on" or "disposed directly on" another element, there are no intervening elements present

**[0016]** FIGS. 1A to 1G illustrate the manufacture of an organic light emitting diode (OLED) display device according to an exemplary embodiment of the present invention. Referring to FIG. 1A, a substrate 100 including a thin film transistor region a and a capacitor region b is prepared, and a buffer layer 110 is formed on the substrate 100. The substrate 100 may be formed of glass or plastic, and the buffer layer 110 may be formed of a single insulating layer, such as one of a silicon oxide layer and a silicon nitride layer, or a stacked layer thereof, using a chemical vapor deposition (CVD) method or a physical vapor deposition (PVD) method.

**[0017]** Here, the buffer layer 110 may function to prevent the diffusion of moisture or impurities from the substrate 100 or to adjust a heat transfer rate in crystallization to facilitate crystallization of a later-formed amorphous silicon layer.

**[0018]** Next, referring to FIG. 1B, an amorphous silicon layer 120a is formed on the buffer layer 110. Then, a diffusion layer 123 and a metal catalyst layer 125 are formed on the amorphous silicon layer 120a. Here, the amorphous silicon layer 120a may be formed by a CVD or PVD method. Further, when the amorphous silicon layer 120a is formed or after the amorphous silicon layer 120a is formed, a dehydrogenation process may be per-

formed to lower the concentration of hydrogen. The diffusion layer 123 may be formed of a silicon nitride layer through which a metal catalyst to be formed in the following process can be diffused in an annealing process, and may be formed of a stacked layer of a silicon nitride layer and a silicon oxide layer. The diffusion layer 123 may be formed by a CVD or PVD method. Here, the diffusion layer 123 may be formed to a thickness of 0.1nm (1Å) to 200nm (2000Å). When the diffusion layer 123 is formed to a thickness less than 0.1nm (1Å), the diffusion layer 123 may not sufficiently control the amount of metal catalyst diffused therethrough. When the thickness of the diffusion layer 123 exceeds 200nm (2000Å), the amount of metal catalyst that diffuses to the amorphous silicon layer 120a is small, and thus it may be difficult to crystallize the amorphous silicon layer into a polysilicon layer.

**[0019]** A metal catalyst is deposited on the diffusion layer 123 to form the metal catalyst layer 125. Here, one selected from the group consisting of Ni, Pd, Ag, Au, Al, Sn, Sb, Cu, Tb, and Cd. For example, nickel (Ni) may be used as the metal catalyst. Here, the metal catalyst layer 125 may be formed with an areal density of 1011 atoms/cm<sup>2</sup> to 1015 atoms/cm<sup>2</sup> on the diffusion layer 123. When the metal catalyst is formed with an areal density less than 1011 atoms/cm<sup>2</sup>, the amount of seeds that are crystallization nuclei is small, and thus the amorphous silicon layer may not be crystallized into a polysilicon layer using a super grain silicon (SGS) method. Alternatively, when the metal catalyst is formed with an areal density greater than 1015 atoms/cm<sup>2</sup>, the amount of metal catalyst diffused into the amorphous silicon layer is great, and thus grains of a resultant polysilicon layer are small. Furthermore, as the amount of remaining metal catalyst increases in the resultant polysilicon layer, characteristics of a semiconductor layer formed by patterning the polysilicon layer deteriorate.

**[0020]** As described above, an annealing process is performed on the substrate 100 on which the buffer layer 110, the amorphous silicon layer 120a, the diffusion layer 123, and the metal catalyst layer 125 are formed to move at least a portion of the metal catalyst of the metal catalyst layer 125 to a surface of the amorphous silicon layer 120a. That is, only a small amount of metal catalyst diffuses through the diffusion layer 123 to the surface of the amorphous silicon layer 120a, and most of the metal catalyst does not reach the amorphous silicon layer 120a or pass through the diffusion layer 123.

**[0021]** Therefore, the amount of metal catalyst reaching the surface of the amorphous silicon layer 120a is determined depending on a diffusion blocking ability of the diffusion layer 123, and the diffusion blocking ability of the diffusion layer 123 is closely related to the thickness of the diffusion layer 123. For example, as the diffusion layer 123 becomes thicker, the amount of metal catalyst to be diffused is reduced, and thus the grain size is increased. Moreover, as the diffusion layer becomes thinner, the amount of metal catalyst to be diffused is increased, and thus the grain size is reduced.

**[0022]** Here, the annealing process may be performed at a temperature of 200°C to 900°C, for example, 350°C to 500°C for several seconds to several hours to diffuse the metal catalyst of the metal catalyst layer 125 to the amorphous silicon layer 120a. When the annealing process is performed at such a temperature for such a time period, deformation of a substrate caused by an excessive annealing process can be prevented to increase manufacturing yield and to reduce manufacturing costs. The annealing process may be performed using one of a furnace process, a rapid thermal annealing (RTA) process, an UV process, and a laser process (i.e., any of these processes).

**[0023]** After the amorphous silicon layer 120a is crystallized into the polysilicon layer, the diffusion layer 123 and the metal catalyst layer 125 are removed. Referring to FIG. 1C, the amorphous silicon layer 120a crystallized into the polysilicon layer is patterned to form a semiconductor layer 120. Here, the semiconductor layer may be patterned using dry etching.

**[0024]** When the polysilicon layer is patterned into the semiconductor layer 120 using dry etching, grain boundaries on which metal silicides of the polysilicon layer crystallized by the metal catalyst gather and a seed region are not completely removed from the surface of the etched buffer layer and remain as a protrusion A. Therefore, the protrusion A remaining on the buffer layer 110 is formed in the same shape as a grain boundary that is formed by crystallizing the amorphous silicon layer into the polysilicon layer. In addition, when the grain size of the semiconductor layer 120 formed of the polysilicon layer is great, the frequency of the protrusions A on the buffer layer is reduced, and when the grain size is small, the frequency of the protrusions A is increased.

**[0025]** FIG. 2 is a photograph showing a surface of a buffer layer after a polysilicon layer crystallized by a metal catalyst is removed by dry etching. Referring to FIG. 2, a protrusion formed to a thickness of up to 68nm (680Å) is observed on the buffer layer 110, and a step difference of the protrusion may vary depending on crystallization condition and thickness of the removed polysilicon layer.

**[0026]** Referring to FIG. 1D, a gate insulating layer 130 is formed on the surface of the substrate 100 on which the semiconductor layer 120 is formed. The gate insulating layer 130 is formed to cover at least a portion of the semiconductor layer 120 to insulate the semiconductor layer 120 from a later formed gate electrode or may be formed on the entire surface of the substrate 100 to cover the semiconductor layer 120. The gate insulating layer 130 may be formed of a silicon oxide layer, a silicon nitride layer or a combination thereof, and the protrusions A of the buffer layer causes the gate insulating layer 130 and the lower capacitor electrode 145 to have protrusions A in the same shape.

**[0027]** Afterwards, a single layer of aluminum (Al) or an aluminum alloy, such as aluminum-neodymium (Al-Nd), or a multilayer in which an aluminum alloy is stacked on a chromium (Cr) or molybdenum (Mo) alloy is used

to form a metal layer for a gate electrode (not shown). Then, the metal layer for a gate electrode is etched using photolithography and etching to form a gate electrode 140 facing the semiconductor layer 120 in the thin film transistor region a at a predetermined region of the semiconductor layer 120, i.e., a channel region thereof, and a lower capacitor electrode 145 in the capacitor region b.

**[0028]** Therefore, the protrusions are formed on the lower capacitor electrode 145, and thus a surface area of the electrode is increased. As a result, the increased surface area causes a capacitance of the capacitor to be increased when the capacitor is completely formed.

**[0029]** Referring to FIG. 1E, an interlayer insulating layer 150 is formed on the surface of the substrate 100 on which the gate electrode 140 and the lower capacitor electrode 145 are formed. The interlayer insulating layer 150 may be formed to cover the entire surface of the substrate 100, including the gate electrode 140 and the lower capacitor electrode 145, or may be formed to cover at least a portion of each of the gate electrode 140 and the lower capacitor electrode 145. Afterwards, a metal layer for source and drain electrodes (not shown) is formed on the surface of the interlayer insulating layer and then patterned, so that source and drain electrodes 160a and 160b disposed in the thin film transistor region a and electrically connected to the semiconductor layer 120, and an upper capacitor electrode 163 disposed on the capacitor region b and facing the lower electrode 145 are formed. The source and drain electrodes 160a and 160b are electrically connected to source and drain regions of the semiconductor layer 120 via through holes formed in the interlayer insulating layer 150 and the gate insulating layer 130. Further, because the lower capacitor electrode 145 and the upper capacitor electrode 163 follow the shape of the protrusions A of the buffer layer 110 and have an increased area, the capacitance of the resultant capacitor is increased.

**[0030]** The interlayer insulating layer 150 may be formed of a silicon nitride layer, a silicon oxide layer, or a combination thereof. Also, the source and drain electrodes 160a and 160b and the upper capacitor electrode 163 may be formed of one selected from the group consisting of molybdenum (Mo), chromium (Cr), tungsten (W), molybdenum-tungsten (MoW), aluminum (Al), aluminum-neodymium (Al-Nd), titanium (Ti), titanium nitride (TiN), copper (Cu), a Mo alloy, an Al alloy, and a Cu alloy.

**[0031]** Afterwards, referring to FIG. 1F, after a protection layer 170 is formed on the entire surface of the substrate, a first electrode 180 connected to one of the source and drain electrodes 160a and 160b of the thin film transistor region a is formed on the protection layer 170. The first electrode 180 is connected to the one of the source and drain electrodes 160a and 160b via a through hole formed in the protective layer 170.

**[0032]** The first electrode 180 may be formed as an anode or a cathode. When the first electrode 180 is formed as an anode, the anode may be formed of a transparent conductive layer made of ITO, IZO or ITZO; and

when the first electrode 180 is formed as a cathode, the cathode may be formed of Mg, Ca, Al, Ag, Ba, or alloys thereof.

**[0033]** Referring to FIG. 1G, a pixel defining layer 185 having an opening to at least partially expose the first electrode 180 is formed on the protective layer 170. The pixel defining layer 185 may also be formed to cover at least a portion of the first electrode 180. An organic layer 190, including a light emitting layer, is formed on the exposed first electrode 180. The organic layer 190 may comprise a hole injection layer, a hole transport layer, a hole blocking layer, an electron blocking layer, an electron injection layer, and an electron transport layer. A second electrode 195 is formed on the organic layer 190. As a result, the OLED display device according to an example embodiment of the present invention is completed.

**[0034]** While a polysilicon layer crystallized using a SGS method is described, MILC and MIC methods in which crystallization is performed using a metal catalyst can be used as the method of crystallizing the amorphous silicon layer, and the methods may be used alone or in combination.

**[0035]** According to aspects of the present invention, an amorphous silicon layer is crystallized using a metal catalyst to form a semiconductor layer formed of a polysilicon layer. Further, protrusions that are formed by residual metals remaining in the silicon layer upon crystallization on a buffer layer in the form of metal silicides cause a surface area of the buffer layer to be increased. As a result, an OLED display device may have a capacitor formed on the buffer layer whose capacitance is increased.

**[0036]** Although a few embodiments of the present invention have been shown and described, it would be appreciated by those skilled in the art that changes may be made in these embodiments without departing from the principles of the invention, the scope of which is defined in the claims.

## Claims

1. An organic light emitting diode OLED display device, comprising:

a substrate (100) having a thin film transistor region (a) and a capacitor region (b);  
a buffer layer (110) disposed on the substrate, the buffer layer having protrusions in the capacitor region (b) that extend away from the substrate; and  
a capacitor (145, 150, 163) disposed on the buffer layer in the capacitor region,

wherein the capacitor follows the shape of the protrusions of the buffer layer.

2. The OLED display device of claim 1, wherein the protrusions extend to a height of up to 68nm from the surface of the buffer layer (110).
3. The OLED display device of claim 1 or 2, further comprising:  
 a semiconductor layer (120) disposed on the buffer layer (110) in the thin film transistor region, wherein the protrusions are formed in the buffer layer except for the portion of the buffer layer on which the semiconductor layer is formed.
4. The OLED display device of any one of the preceding claims, wherein the capacitor comprises:  
 a first capacitor electrode (145) disposed on the buffer layer;  
 an interlayer insulating layer (150) disposed on the first electrode; and  
 a second capacitor electrode (163) disposed on the interlayer insulating layer,  
 wherein the first capacitor electrode, the second capacitor electrode and the interlayer insulating layer follow the shape of the protrusions of the buffer layer.
5. The OLED display device of any one of the preceding claims, further comprising a gate insulating layer (130) disposed on the buffer layer between the buffer layer and the capacitor.
6. The OLED display device of any one of the preceding claims, wherein the buffer layer has a higher concentration of metal silicides near the protrusions.
7. The OLED display device of claim 3, wherein the protrusions follow the shape of grain boundaries of the semiconductor layer.
8. The OLED display device of claim 5, further comprising a gate electrode on the gate insulating layer, wherein the gate electrode is formed of one of a single layer of aluminum (Al), a single layer of an aluminum (Al) alloy, a multilayer of a chromium (Cr) alloy and an aluminum (Al) alloy, and a multilayer of a molybdenum (Mo) alloy and an aluminum (Al) alloy.
9. The OLED display device of claim 8, wherein the first capacitor electrode is formed of the same material as the gate electrode, and/or wherein the buffer layer is formed of a silicon oxide layer, a silicon nitride layer, or a stacked layer thereof, and/or wherein the second capacitor electrode is formed of the same material as the source and drain electrodes, and/or wherein the second capacitor electrode is formed of one selected from the group consisting of molybdenum (Mo), chromium (Cr), tungsten (W), molybdenum-tungsten (MoW), aluminum (Al), aluminum-neodymium (Al-Nd), titanium (Ti), titanium nitride (TiN), copper (Cu), a Mo alloy, an Al alloy, and a Cu alloy.
10. The OLED display device of claim 3, wherein, when the grain size of the semiconductor layer is decreased, the buffer layer has more protrusions and/or wherein the protrusions are formed where seeds of crystallization of the semiconductor layer were disposed before the semiconductor layer was patterned.
11. A method of fabricating an organic light emitting diode (OLED) display device, the method comprising:  
 forming a substrate (100) having a thin film transistor region and a capacitor region;  
 forming a buffer layer (110) on the substrate;  
 forming protrusions in the buffer layer; and  
 forming a capacitor (145, 150, 163) on the buffer layer in the capacitor region,  
 wherein the capacitor follows the shape of the protrusions of the buffer layer.
12. The method of claim 11, wherein the step of forming protrusions in the buffer layer comprises:  
 forming an amorphous silicon layer (120a) on the buffer layer;  
 forming a metal catalyst layer (125) on the amorphous silicon layer;  
 annealing the substrate to crystallize the amorphous silicon layer into a polysilicon layer;  
 removing the metal catalyst layer (125); and  
 patterning the polysilicon layer to form a semiconductor layer (120) in the thin film transistor region.
13. The method of claim 12, further comprising:  
 forming a gate insulating layer (130) on the substrate to cover the semiconductor layer;  
 forming a gate electrode (140) on the gate insulating layer to face a predetermined region of the semiconductor layer;  
 forming a first capacitor electrode (145) on the gate insulating layer in the capacitor region;  
 forming an interlayer insulating layer (150) on the substrate to cover the gate electrode and the first capacitor electrode;  
 forming source and drain electrodes (160a, 160b) on the interlayer insulating layer which are electrically connected to the semiconductor layer;

forming a second capacitor electrode (163) on the interlayer insulating layer to face the first capacitor electrode;  
forming a first electrode (180) on the interlayer insulating layer, the first electrode being electrically connected to one of the source and drain regions of the semiconductor layer;  
forming an organic layer (190) on the first electrode, the organic layer including a light emitting layer; and  
forming a second electrode (195) on the organic layer.

5

10

14. The method of claim 12 or 13, further comprising:

15

forming a diffusion layer (123) on the amorphous silicon layer (120a) and forming the metal catalyst layer (125) on the diffusion layer,

wherein the annealing is performed after the forming of the metal catalyst layer.

20

15. The method of claim 13, wherein the first capacitor electrode and the gate electrode are formed by simultaneous patterning and/or wherein the second capacitor electrode and the source and drain electrodes are formed by simultaneous patterning.

25

30

35

40

45

50

55

FIG. 1A

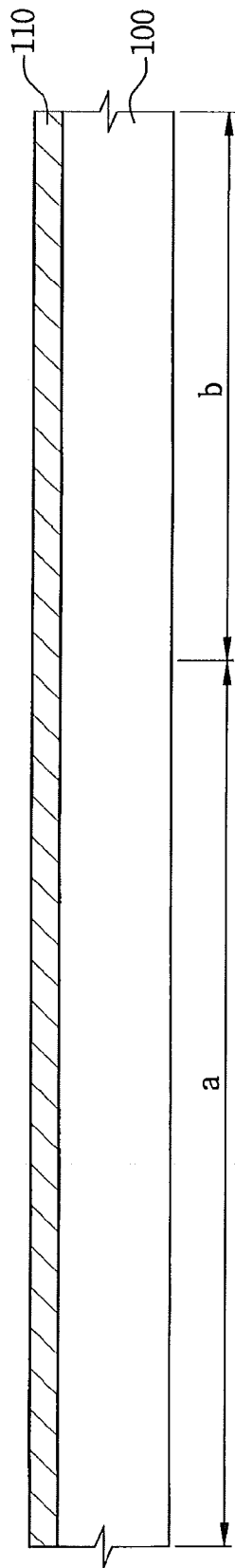

FIG. 1B

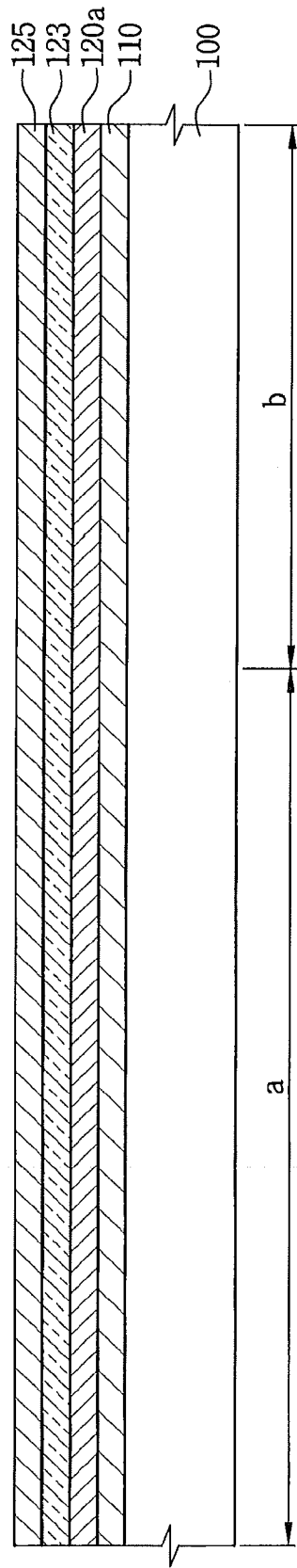

FIG. 1C

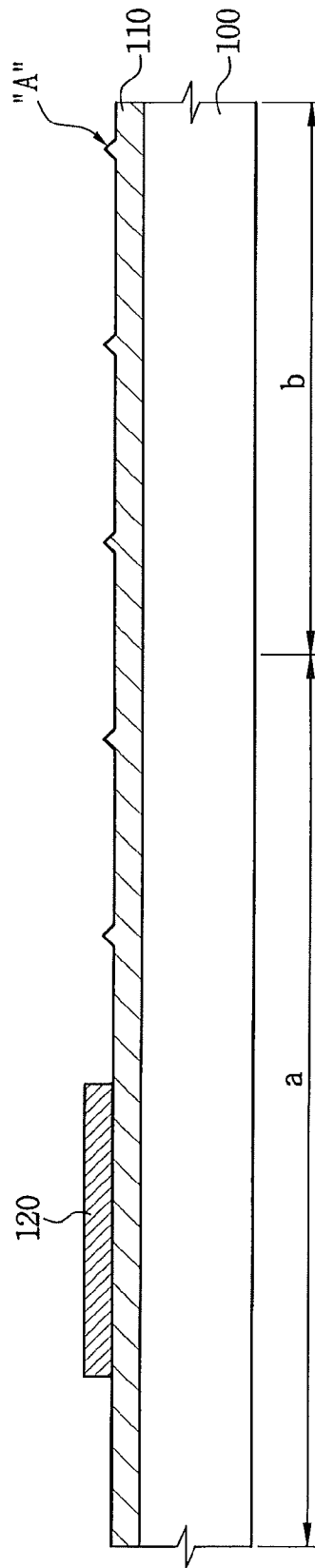

FIG. 1D

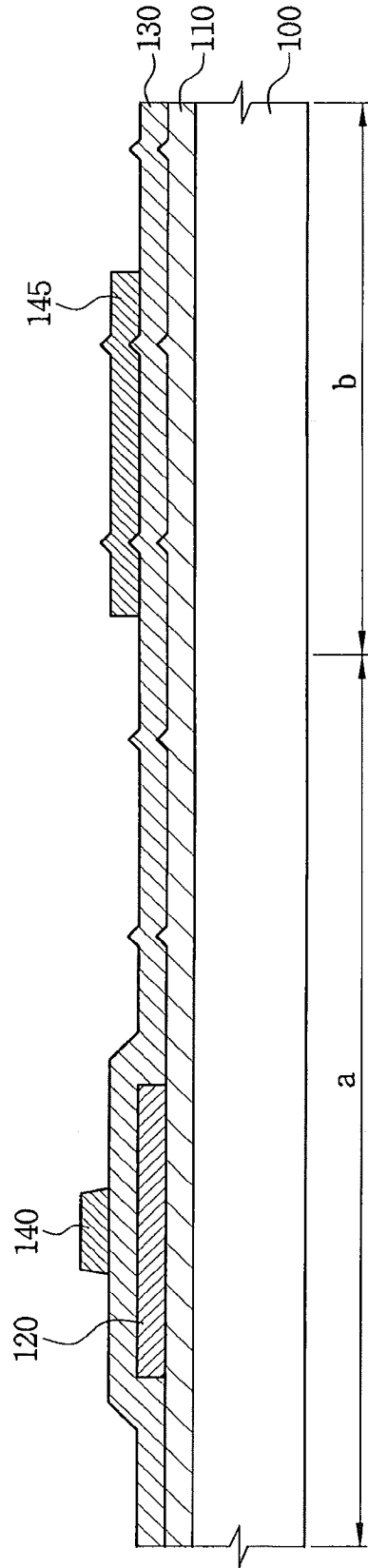

FIG. 1E

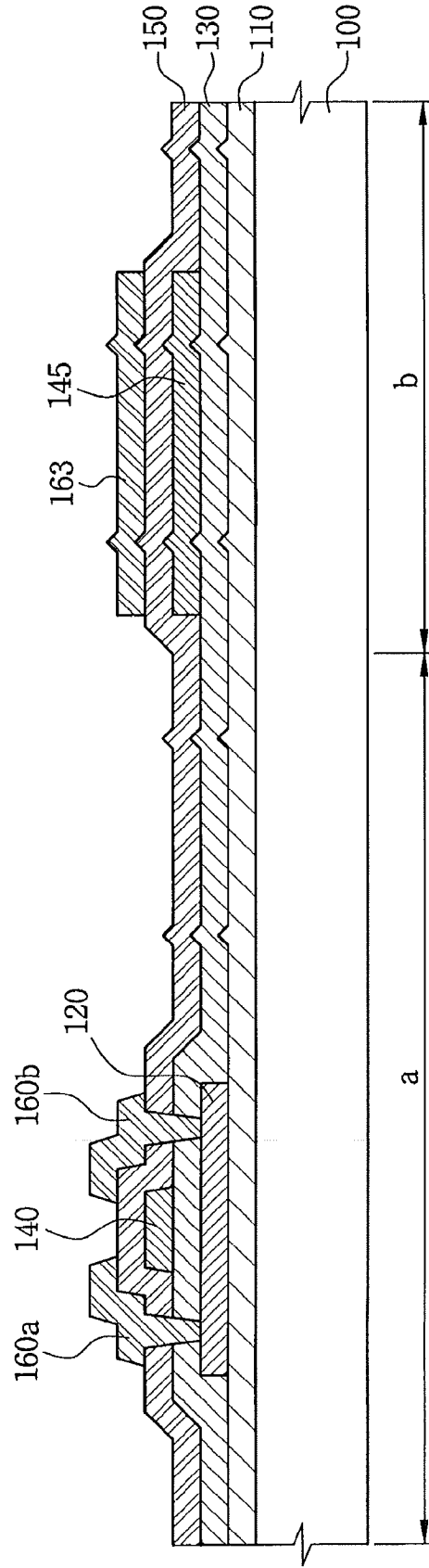

FIG. 1F

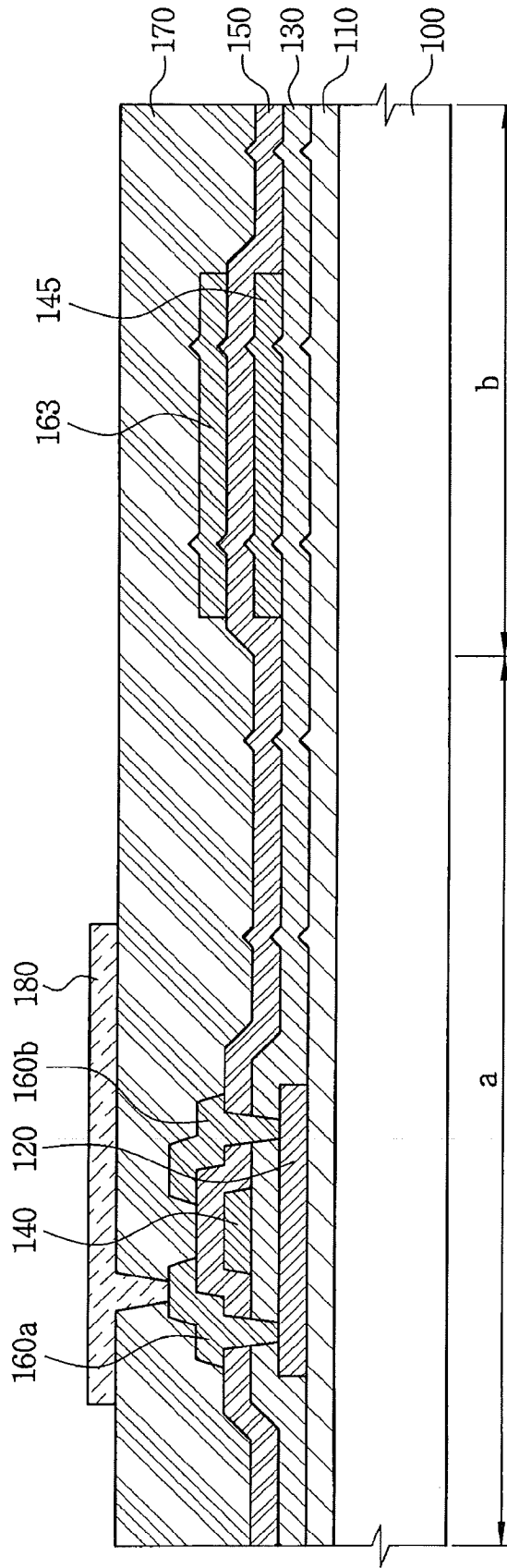

FIG. 1G

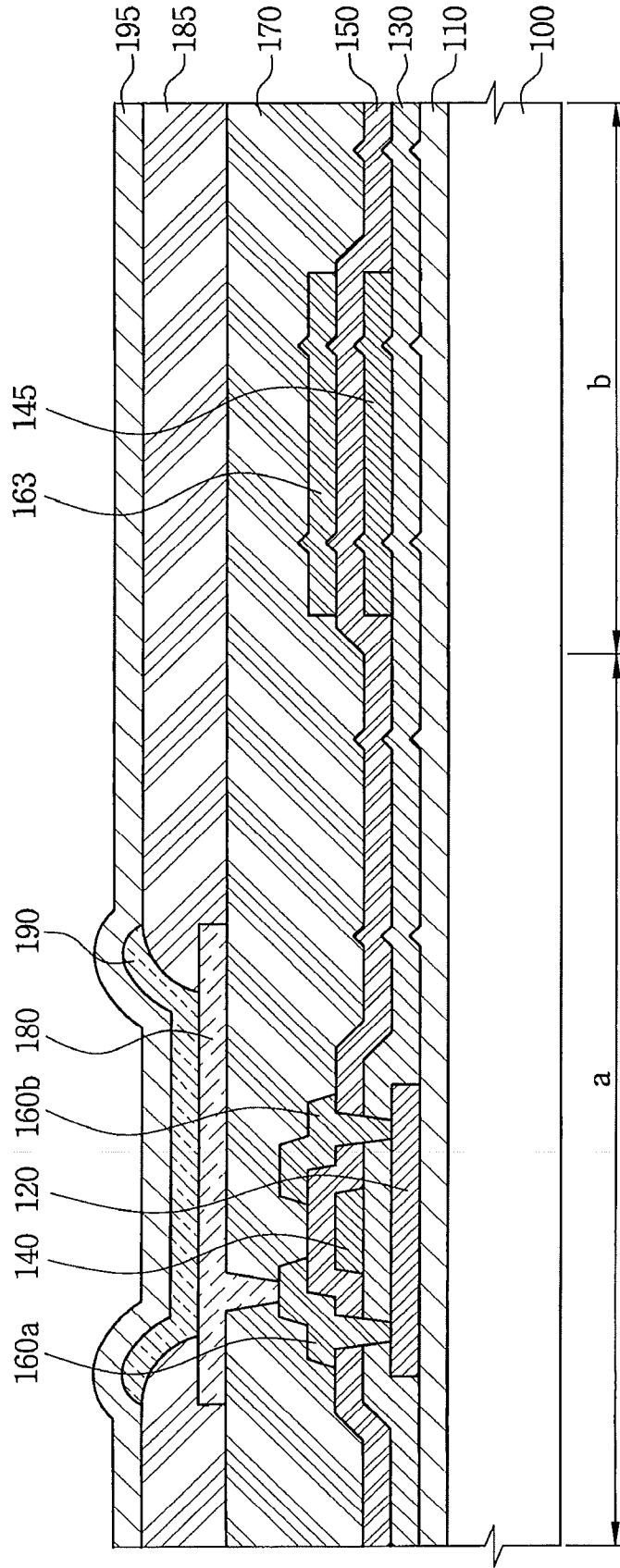
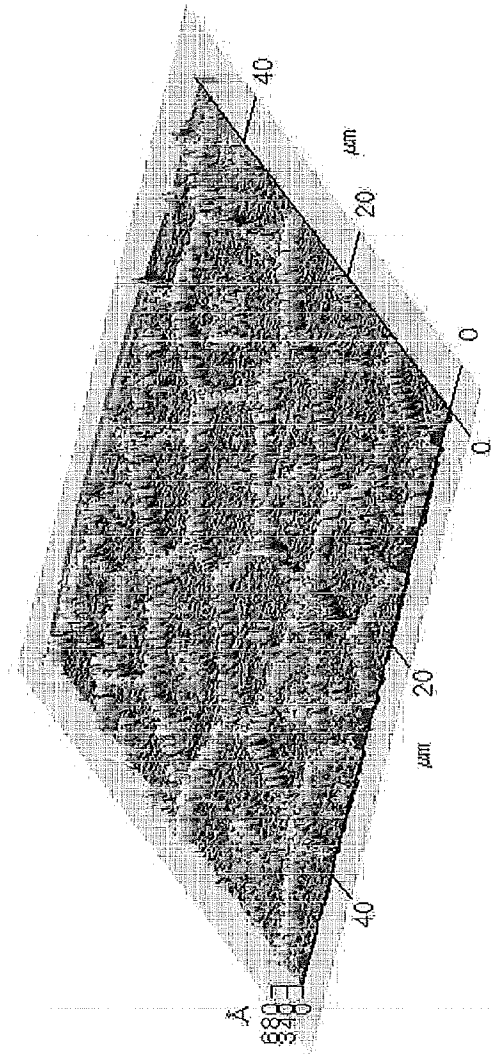

FIG.2



专利名称(译)	有机发光二极管显示装置及其制造方法		
公开(公告)号	<a href="#">EP2226845A2</a>	公开(公告)日	2010-09-08
申请号	EP2010154502	申请日	2010-02-24
[标]申请(专利权)人(译)	三星显示有限公司		
申请(专利权)人(译)	三星移动显示器有限公司.		
当前申请(专利权)人(译)	三星移动显示器有限公司.		
[标]发明人	PARK BYOUNG KEON YANG TAE HOON SEO JIN WOOK JO SOO BEOM LEE DONG HYUN LEE KIL WON LISACHENKO MAXIM CHUNG YUN MO CHOI BO KYUNG PARK JONG RYUK LEE KI YONG		
发明人	PARK, BYOUNG-KEON YANG, TAE-HOON SEO, JIN-WOOK JO, SOO-BEOM LEE, DONG-HYUN LEE, KIL-WON LISACHENKO, MAXIM CHUNG, YUN-MO CHOI, BO-KYUNG PARK, JONG-RYUK LEE, KI-YONG		
IPC分类号	H01L27/32		
CPC分类号	H01L27/3265 H01L2227/323 H01L51/52		
优先权	1020090018200 2009-03-03 KR		
其他公开文献	EP2226845B1 EP2226845A3		
外部链接	<a href="#">Espacenet</a>		

#### 摘要(译)

提供了一种有机发光二极管 ( OLED ) 显示装置及其制造方法。 OLED显示装置包括具有薄膜晶体管区域和电容器区域的基板，设置在基板上的缓冲层，设置在基板上的栅极绝缘层，设置在电容器区域中的栅极绝缘层上的下电容器电极，层间绝缘层设置于基板上，上层电容器电极设置于层间绝缘层上且面向下层电容器电极，其中缓冲层，栅极绝缘层，层间绝缘层，下电容器电极各自的区域上电容器电极具有这样的表面，其中形成具有与半导体层的晶界相同形状的突起。所得到的电容器具有增大的表面积，因此增加了电容。

FIG. 1G

