

(19) World Intellectual Property Organization
International Bureau



(43) International Publication Date
3 January 2008 (03.01.2008)

PCT

(10) International Publication Number
WO 2008/002422 A2

- (51) International Patent Classification:
G09G 3/32 (2006.01)
- (21) International Application Number:
PCT/US2007/014323
- (22) International Filing Date: 20 June 2007 (20.06.2007)
- (25) Filing Language: English
- (26) Publication Language: English
- (30) Priority Data:
11/427,104 28 June 2006 (28.06.2006) US
- (71) Applicant (for all designated States except US): **EASTMAN KODAK COMPANY** [US/US]; 343 State Street, Rochester, New York 14650-2201 (US).
- (72) Inventors; and
- (75) Inventors/Applicants (for US only): **HAMER, John William** [CA/US]; 226 Straub Road, Rochester, New York 14626 (US). **PARRETT, Gary** [US/US]; 1909 Westside Drive, Rochester, New York 14624 (US).
- (74) Common Representative: **EASTMAN KODAK COMPANY**; 343 State Street, Rochester, New York 14650-2201 (US).

- (81) Designated States (unless otherwise indicated, for every kind of national protection available): AE, AG, AL, AM, AT, AU, AZ, BA, BB, BG, BH, BR, BW, BY, BZ, CA, CH, CN, CO, CR, CU, CZ, DE, DK, DM, DO, DZ, EC, EE, EG, ES, FI, GB, GD, GE, GH, GM, GT, HN, HR, HU, ID, IL, IN, IS, JP, KE, KG, KM, KN, KP, KR, KZ, LA, LC, LK, LR, LS, LT, LU, LY, MA, MD, ME, MG, MK, MN, MW, MX, MY, MZ, NA, NG, NI, NO, NZ, OM, PG, PH, PL, PT, RO, RS, RU, SC, SD, SE, SG, SK, SL, SM, SV, SY, TJ, TM, TN, TR, TT, TZ, UA, UG, US, UZ, VC, VN, ZA, ZM, ZW.
- (84) Designated States (unless otherwise indicated, for every kind of regional protection available): ARIPO (BW, GH, GM, KE, LS, MW, MZ, NA, SD, SL, SZ, TZ, UG, ZM, ZW), Eurasian (AM, AZ, BY, KG, KZ, MD, RU, TJ, TM), European (AT, BE, BG, CH, CY, CZ, DE, DK, EE, ES, FI, FR, GB, GR, HU, IE, IS, IT, LT, LU, LV, MC, MT, NL, PL, PT, RO, SE, SI, SK, TR), OAPI (BF, BJ, CF, CG, CI, CM, GA, GN, GQ, GW, ML, MR, NE, SN, TD, TG).

Published:
— without international search report and to be republished upon receipt of that report

For two-letter codes and other abbreviations, refer to the "Guidance Notes on Codes and Abbreviations" appearing at the beginning of each regular issue of the PCT Gazette.

(54) Title: ACTIVE MATRIX DISPLAY COMPENSATING APPARATUS

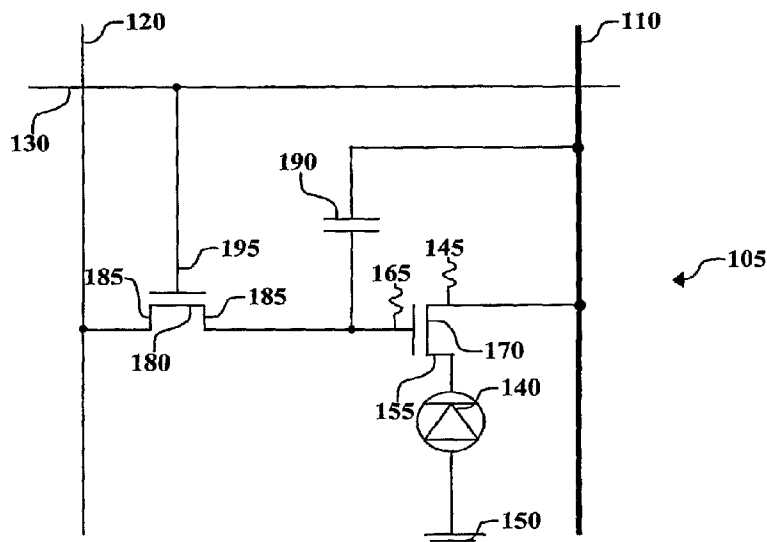

(57) Abstract: An apparatus for determining an adjustment to a signal voltage for compensating for changes in the threshold voltage (V_{th}) for a drive transistor in a pixel drive circuit in an active matrix OLED display having at least one OLED light-emitting pixel, comprising: the pixel drive circuit having a data line, a power supply line, a drive transistor; the drive transistor being electrically connected to the power supply line and to the OLED light-emitting pixel; the switch transistor being electrically connected to the gate electrode of the drive transistor and to the data line; first means for applying a first voltage to the power supply line; second means for applying a second voltage to the power supply line opposite in polarity to the first voltage; third means for producing a threshold-voltage-related signal on the data line; and fourth means responsive to the threshold-voltage-related signal for calculating the adjustment to the signal voltage.

WO 2008/002422 A2

ACTIVE MATRIX DISPLAY COMPENSATING APPARATUS

FIELD OF THE INVENTION

The present invention relates to an active matrix-type display
5 apparatus for driving display elements.

BACKGROUND OF THE INVENTION

In recent years, it has become necessary that image display devices
have high-resolution and high picture quality, and it is desirable for such image
display devices to have low power consumption and be thin, lightweight, and
10 visible from wide angles. With such requirements, display devices (displays) have
been developed where thin-film active elements (thin-film transistors, also
referred to as TFTs) are formed on a glass substrate, with display elements then
being formed on top.

In general, a substrate forming active elements is such that
15 patterning and interconnects formed using metal are provided after forming a
semiconductor film of amorphous silicon or polysilicon etc. Due to differences in
the electrical characteristics of the active elements, the former requires ICs
(Integrated Circuits) for drive use, and the latter is capable of forming circuits for
drive use on the substrate. In liquid crystal displays (LCDs) currently widely used,
20 the amorphous silicon type is widespread for large-type screens, while the
polysilicon type is more common in medium and small screens.

Typically, organic EL elements are used in combination with TFTs
and utilize a voltage/current control operation so that current is controlled. The
current/voltage control operation refers to the operation of applying a signal
25 voltage to a TFT gate terminal so as to control current between the source and
drain. As a result, it is possible to adjust the intensity of light emitted from the
organic EL element and to control the display to the desired gradation.

However, in this configuration, the intensity of light emitted by the
organic EL element is extremely sensitive to the TFT characteristics. In particular,
30 for amorphous silicon TFTs (referred to as a-Si), it is known that comparatively

large differences in electrical characteristics occur with time between neighboring pixels, due to changes in transistor threshold voltage. This is a major cause of deterioration of the display quality of organic EL displays, in particular, screen uniformity. Uncompensated, this effect can lead to "burned-in" images on the screen.

Goh et al. (IEEE Electron Device Letters, Vol. 24, No. 9, pp. 583-585) have proposed a pixel circuit with a precharge cycle before data loading, to compensate for this effect. Compared to the standard OLED pixel circuit with a capacitor, a select transistor, a power transistor, and power, data, and select lines, Goh's circuit uses an additional control line and two additional switching transistors. Jung et al. (IMID '05 Digest, pp. 793-796) have proposed a similar circuit with an additional control line, an additional capacitor, and three additional transistors. While such circuits can be used to compensate for changes in the threshold voltage of the driving transistor, they add to the complexity of the display, thereby increasing the cost and the likelihood of defects in the manufactured product. Further, such circuitry generally comprises thin-film transistors (TFTs) and necessarily uses up a portion of the substrate area of the display. For bottom-emitting devices, the aperture ratio is important, and such additional circuitry reduces the aperture ratio, and can even make such bottom-emitting displays unusable. Thus, there exists a need to compensate for changes in the electrical characteristics of the pixel circuitry in an OLED display without reducing the aperture ratio of such a display.

SUMMARY OF THE INVENTION

It is therefore an object of the present invention to provide an apparatus and method of compensating for changes in the electrical characteristics of the pixel circuitry in an OLED display.

This object is achieved by an apparatus for determining an adjustment to a signal voltage for compensating for changes in the threshold voltage (V_{th}) for a drive transistor in a pixel drive circuit in an active matrix OLED display having at least one OLED light-emitting pixel, comprising:

- a) the pixel drive circuit having a data line, a power supply line, a drive transistor having source, drain, and gate electrodes, and a switch transistor having source, drain, and gate electrodes;
- b) the source or drain electrode of the drive transistor being electrically connected to the power supply line, and the other of the source or drain electrode being electrically connected to the OLED light-emitting pixel;
- c) the source or the drain electrode of the switch transistor being electrically connected to the gate electrode of the drive transistor, and the other of the source or drain electrode being electrically connected to the data line;
- d) first means for applying a first voltage to the power supply line which is either positive or negative for causing current to flow in a first direction through the drive transistor which causes the OLED light-emitting pixel to produce light in response to the signal voltage;
- e) second means for applying a second voltage to the power supply line opposite in polarity to the first voltage so that current will flow through the drive transistor in a second direction opposite to the first direction until the potential on the gate electrode of the drive transistor causes the drive transistor to turn off;
- f) third means for producing a threshold-voltage-related signal on the data line which is a function of the potential on the gate electrode of the drive transistor; and
- g) fourth means responsive to the threshold-voltage-related signal for calculating the adjustment to the signal voltage.

ADVANTAGES

It is an advantage of the present invention that it can compensate for changes in the electrical characteristics of the thin-film transistors of an OLED display. It is a further advantage of this invention that it can so compensate without reducing the aperture ratio of a bottom-emitting OLED display and without increasing the complexity of the within-pixel circuits.

BRIEF DESCRIPTION OF THE DRAWINGS

FIG. 1 shows a schematic diagram of an OLED pixel drive circuit well-known in the art;

FIG. 2 shows a schematic diagram of one embodiment of a common OLED pixel drive circuit that is useful in this invention;

FIG. 3 shows a schematic diagram of another embodiment of a common OLED pixel drive circuit that is useful in this invention;

FIG. 4A through 4D show the stepwise results of the operations of this invention on a portion of an example pixel drive circuit;

FIG. 5 shows a schematic diagram of one embodiment of a circuit according to this invention for determining an error-correcting voltage for compensating for changes in the threshold voltages for a drive transistor in a pixel drive circuit in an active matrix OLED display; and

FIG. 6 shows a block diagram of one embodiment of a method according to this invention for determining an error-correcting voltage for compensating for changes in the threshold voltages for a drive transistor in a pixel drive circuit in an active matrix OLED display.

DETAILED DESCRIPTION OF THE INVENTION

Turning now to FIG. 1, there is shown a schematic diagram of one embodiment of an OLED pixel drive circuit that can be used in this invention. Such pixel drive circuits are well known in the art in active matrix OLED displays. OLED pixel drive circuit 100 has a data line 120, a power supply line 110, a select line 130, a drive transistor 170, a switch transistor 180, an OLED light-emitting pixel 160, and a capacitor 190. Drive transistor 170 has drain electrode 145, source electrode 155, and gate electrode 165. In pixel drive circuit 100, drain electrode 145 of drive transistor 170 is electrically connected to power supply line 110, while source electrode 155 is electrically connected to OLED light-emitting pixel 160. By electrically connected, it is meant that the elements are directly connected or connected via another component, e.g. a switch, a diode, another transistor, etc. It will be understood that embodiments are possible wherein the

source and drain electrode connections are reversed. OLED light-emitting pixel 160 is a non-inverted OLED pixel, wherein the anode of the pixel is electrically connected to power line 110 and the cathode of the pixel is electrically connected to ground 150. Switch transistor 180 has gate electrode 195, as well as source and drain electrodes, together represented as source or drain electrodes 185 because
5 such transistors are commonly bidirectional. Of the source and drain electrodes 185 of switch transistor 180, one is electrically connected to the gate electrode 165 of drive transistor 170, while the other is electrically connected to data line 120. Gate electrode 195 is electrically connected to select line 130. OLED light-
10 emitting pixel 160 is powered by flow of current between power supply line 110 and ground 150. In this embodiment, power supply line 110 has a positive potential, relative to ground 150, for driving OLED light-emitting pixel 160. The normal driving potential will herein be referred to as the first voltage and is positive for this embodiment. It will cause current to flow through drive transistor
15 170 and OLED light-emitting pixel 160 in a first direction, that is, electrons will flow from ground 150 to power line 110, which will cause OLED light-emitting pixel 160 to produce light. The magnitude of the current—and therefore the intensity of the emitted light—is controlled by drive transistor 170, and more exactly by the magnitude of the signal voltage on gate electrode 165 of drive
20 transistor 170. During a write cycle, select line 130 activates switch transistor 180 for writing and the signal voltage data on data line 120 is written to drive transistor 170 and stored on capacitor 190, which is connected between gate electrode 165 and power supply line 110.

Turning now to FIG. 2, there is shown a schematic diagram of
25 another embodiment of an OLED pixel drive circuit that can be used in this invention. Pixel drive circuit 105 is constructed much as pixel drive circuit 100 described above. However, OLED light-emitting pixel 140 is an inverted OLED pixel, wherein the cathode of the pixel is electrically connected to power line 110 and the anode of the pixel is electrically connected to ground 150. In this
30 embodiment, power supply line 110 must have a negative potential, relative to ground 150, for driving OLED light-emitting pixel 160. Therefore, the first

voltage is negative relative to ground 150 for this embodiment and the first direction in which current flows so as to drive OLED light-emitting pixel 140 will be the reverse of that in FIG. 1. It will be understood in the examples to follow that one can reverse the potentials and current directions if necessary for the structure and function of the OLED pixel drive circuits, and that such
5 modifications are within the scope of this invention.

The above embodiments are constructed wherein the drive transistors and switch transistors are n-channel transistors. It will be understood by those skilled in the art that embodiments wherein the drive transistors and
10 switch transistors are p-channel transistors, with appropriate well-known modifications to the circuits, can also be useful in this invention.

In practice in active-matrix displays, the capacitance is often not provided as a separate entity, but in a portion of the thin-film transistor sections that form the drive transistor. FIG. 3 shows a schematic diagram of one
15 embodiment of a common OLED pixel drive circuit 200 of this type, which is useful in this invention. Drive transistor 210 also incorporates a capacitor 230 connected between gate electrode 215 and power line 110. This will also be referred to as the gate-power capacitor, or C_{gp} . Drive transistor 210 generally inherently includes a smaller parasitic capacitor 230 connected between gate
20 electrode 215 and OLED light-emitting pixel 160. This will also be referred to as the gate-OLED capacitor, or C_{go} . In some embodiments, the relative magnitude of C_{gp} and C_{go} can be reversed. As in pixel drive circuit 100, the first voltage is positive for normal operation of OLED light-emitting pixel 160. If the potential is reversed (e.g. power supply line 110 has a negative voltage relative to ground
25 150), OLED light-emitting pixel 160 will be in an inoperative condition and will function instead as a capacitor having a capacitance C_{OLED} . This potential, which is opposite in polarity to the first voltage, will herein be referred to as the second voltage. This will cause current to flow through drive transistor 210 in a second direction opposite to the above first direction. However, current flow in the
30 second direction will only occur until the various capacitors in the circuit, including the OLED light-emitting pixel, become charged and cause the drive

transistor to turn off. The use of this property of the pixel drive circuits described herein is an important feature of this invention, which will now be illustrated.

Turning now to FIG. 4A through 4D, there are shown the stepwise results of the operations of this invention on a portion of an example pixel drive circuit 200. In preparation for FIG. 4A, a potential of zero volts is placed on power supply line 110 and on gate electrode 215. It is not required for the practice of this invention that power supply line 110 or gate electrode 215 first be set to zero volts; however, doing so will make illustration of the use of this invention clearer. The switch transistor that electrically connects gate electrode 215 to data line 120 is turned off, so that gate electrode 215 is isolated. Then a second voltage of -20V is applied to power supply line 110. With a second voltage, OLED light-emitting pixel 160 is in an inoperative condition and acts as a capacitor. In the example shown here, the OLED capacitance C_{OLED} is 3.5pF , the gate-OLED capacitance C_{go} is 0.089pF , and the gate-power capacitance C_{gp} is 0.275pF . The voltages shown in FIG. 4A are those expected with these capacitances before any current flows if the gate and power supply potentials are both initially zero. If either the gate or power supply potential—or both—is not zero, the resulting voltages will be different, but will still be a function of the capacitances.

Current will then flow through drive transistor 210 in a second direction, that is, electrons will flow from power line 110 to ground 150, and charge the C_{OLED} capacitor. As the charge on C_{OLED} is increased, the potential between the source and drain electrodes of drive transistor 210 is reduced. Simultaneously, the potential on the gate electrode of drive transistor 210 (which is isolated by switch transistor 180) will shift to maintain the ratio of the potential difference from the gate to source and drain in proportion to the inverse of the ratio of respective capacitances:

$$V_{\text{gp}}/V_{\text{go}} = C_{\text{go}}/C_{\text{gp}} \quad (\text{Eq. 1})$$

The current flow will continue until the potential V_{go} between gate electrode 215 of drive transistor 210 and power supply line 110 falls to the value of the drive transistor threshold voltage, which causes the drive transistor to turn off. By turn off, it is meant that the current flow through drive transistor 210 is

substantially zero. However, it is known in the art that transistors can leak small amounts of current under threshold voltage or lower conditions; such transistors can be successfully used in this invention. For illustration purposes, we are assuming in this example that the threshold voltage V_{th} of drive transistor 210 is 3.0V. FIG. 4B shows the resulting voltages stored on the capacitors at this point. These voltages are a function of the threshold voltage of the transistor. Thus, the gate voltage is a threshold-voltage-proportional signal, and can be related to the threshold voltage by Eq. 2, wherein PV_{DD2} represents the second voltage (e.g. -20V in this example) applied to power supply line 110:

$$V_{gate} = PV_{DD2} + V_{th} \quad (\text{Eq. 2})$$

After the voltages have equilibrated as shown in FIG. 4b, select line 130 activates switch transistor 180 to connect gate electrode 215 to data line 120, wherein the gate electrode voltage will be changed by a transfer function, here represented by $f(x)$. The transfer function depends on the characteristics of switch transistor 180, the change in potential of select line 130, the circuit layout, the capacitance and impedance of the external circuits connected to data line 120, and the number of pixels on data line 120 that are switched. One skilled in the art can predict the transfer function based on the design, or can measure it. Thus, the voltage produced on data line 120 (V_{out}) is a threshold-voltage-related signal which is a function of the potential on the gate electrode of the drive transistor, given by:

$$V_{out} = f(V_{gate}) \quad (\text{Eq. 3})$$

The transfer function $f(x)$ can be inverted, represented by $f^{-1}(x)$.

The threshold voltage is calculated from the measured voltage by:

$$V_{th} = f^{-1}(V_{out}) - PV_{DD2} \quad (\text{Eq. 4})$$

Alternatively, before activating switch transistor 180 and measuring the potentials, an additional step can be done wherein the potential of power supply line 110 can then be changed to a third voltage. This will redistribute the potentials based upon the capacitances, as shown in FIG. 4C. If the voltage is chosen correctly, such as zero in this example, current will flow through drive transistor 210 in the direction used to cause the OLED to emit light.

No light will be emitted, as the OLED remains in a reverse bias condition. The current will continue to flow until the gate-to-OLED potential difference is equal to the threshold voltage of the drive transistor for current flow in the direction used for light emission. FIG. 4D shows the resulting voltages on the circuit at this point. The gate voltage can be related to the threshold voltage
 5 by:

$$V_{gate} = PV_{DD3} - \frac{V_{th} C_{gp}}{C_{go}} \quad (\text{Eq. 5})$$

wherein PV_{DD3} represents the third voltage (e.g. zero in this example) applied to power supply line 110. In this case the threshold voltage can be calculated from
 10 the measured voltage by:

$$V_{th} = \frac{-C_{go} (f^{-1}(V_{out}) - PV_{DD3})}{C_{gp}} \quad (\text{Eq. 6})$$

This last step of reducing the reverse driving potential (FIG. 4C and 4D) is useful in the case that the threshold voltage of the driving transistor 210 is different for forward and reverse operation.

15 As the threshold voltage of a transistor can change with usage, it can be necessary to calculate an adjustment for the threshold voltage. This is the difference between the currently-calculated threshold voltage and the initial threshold voltage:

$$\text{Adjustment} = V_{th} - V_{thi} \quad (\text{Eq. 7})$$

20 where V_{thi} represents the initial threshold voltage of the transistor.

Turning now to FIG. 5, and referring also to FIG. 3 through 4D, there is shown a schematic diagram of one embodiment of an apparatus of this invention for determining an adjustment to a signal voltage for compensating for changes in the threshold voltage for a drive transistor in a pixel drive circuit as described herein. Active matrix OLED display 250 has at least one OLED light-emitting pixel, each having a pixel drive circuit 200 as described above. In normal
 25 operation, voltage supply 260, which is a positive power supply, applies a first voltage (also called PV_{DD1}) to power supply line 110 via switch 265 to cause current to flow in a first direction through the drive transistor as described above,

30

which causes OLED light-emitting pixel 160 to produce light. The intensity of the emitted light, which is proportional to the current through drive transistor 170, is responsive to the signal voltage set by data line 120, which is electrically connected to digital-to-analog converter 280. Digital-to-analog converter 280
5 converts a digital input representing the desired intensity of light emitted by a given pixel into an analog signal voltage, which select line 130) allows to be written to the capacitors of the selected pixel circuit. Although not shown for clarity of illustration, it will be understood that OLED display 250 can include a plurality of pixel drive circuits 200 arranged in an array, and further can include
10 multiple power supply lines, select lines, and data lines, as known in the art.

In order to determine an adjustment to a signal voltage for compensating for changes in the threshold voltages (V_{th}) for the drive transistors of OLED display 250, it is necessary to apply a second voltage opposite in polarity to the first voltage to the power supply line and the pixel drive circuit and thus
15 place the OLED in an inoperative condition, as described above. Voltage supply 270, which is a negative power supply in this embodiment, applies a second voltage (PV_{DD2}) opposite in polarity to the first voltage to power supply line 110 via switch 265. As described above, this causes current to flow through the drive transistor in a second direction opposite to the first direction of normal operation,
20 until the potential on the gate electrode of the drive transistor causes the drive transistor to turn off. Switch 265 can also optionally switch the circuit to a third voltage state (PV_{DD3}), e.g. ground 150. During the second and third voltage operations, data line 120 can become an output line providing a threshold-voltage-related signal that is a function of the potential on gate electrode 215 of drive
25 transistor 210. Switch 285 connects data line 120 during such data output to a correlated double sampling circuit 290 which is responsive to the threshold-voltage-related signal. In the case of multiple data lines 120, each data line can have its own correlated double sampling circuit 290, or there can be fewer correlated double sampling circuits, with multiplexing to allow sequential data
30 sampling of all data lines. Correlated double sampling circuit 290 comprises

integrator 310, low pass filter 320, correlated double sampling unit 330, sample-and-hold element 340, and analog-to-digital converter 350. Correlated double sampling circuit 290 is known and is a commercially available integrated circuit for amplification and readout of small charge over long data wires. An example is
5 ISC9717 from Indigo. The data from correlated double sampling circuit 290 goes to a processor 315, which can store it in memory 325 as raw data, or can include computation circuitry for calculating the current threshold voltage for the drive transistor via Eq. 4 or Eq. 6, or via a lookup table. Processor 315 can calculate an adjustment to the signal voltage, via Eq. 7, from the difference between the current
10 threshold voltage and the initial threshold voltage, which is the threshold voltage of drive transistor 210 before any aging takes place. The initial threshold voltage can be measured when pixel drive circuit 200 is new, and subsequently stored in memory. During operation of OLED display 250, processor 315 can apply the adjustment to the signal voltage through digital-to-analog converter 280, which
15 can adjust the signal voltage, and thus apply the adjustment to data line 120, through switch transistor 180 of pixel drive circuit 200, to gate electrode 215 of drive transistor 210. Processor 315 and memory 325 can be made of individual integrated circuits or encapsulated in a single package as an SiP (System in Package). Memory 325 can also be built into processor 315 as an SoC (System on
20 Chip).

In practice, circuits such as correlated double sampling circuit 290 make two measurements for each pixel. The first measurement is made on data line 120 without a signal, e.g. with switch transistor 180 turned off, wherein correlated double sampling circuit 290 obtains the noise level of the data line. The
25 second measurement is made after the potentials have equilibrated, as in FIG. 4B or 4D, and switch transistor 180 has been turned on, wherein correlated double sampling circuit 290 obtains a reading of a threshold-voltage-related signal on data line 120.

Turning now to FIG. 6, and referring also to FIG. 3 through 5, there
30 is shown a block diagram of one embodiment of a method using the apparatus of this invention for determining an adjustment to a signal voltage for compensating

for changes in the threshold voltage for a drive transistor in a pixel drive circuit in an active matrix OLED display, and for applying the adjustment. At the start, the gate voltages of an entire row of pixel drive circuits 200 are set to the initial voltage by setting all data lines 120 to the initial voltage and turning on switch transistor 180 by selecting the appropriate select line 130 (Step 410). The initial gate voltage can conveniently be zero volts, or can be a different preselected voltage. Switch transistors 180 are then turned off (Step 420). Then a second voltage opposite in polarity to the first driving voltage is applied to OLED light-emitting pixel 160 by connecting negative voltage supply 270 to power supply line 110 via switch 265 (Step 430), thus placing the OLED in an inoperative condition. Then current is allowed to flow through the circuit (Step 440) to charge the capacitors: OLED 160, gate-OLED capacitor 220, and gate-power capacitor 230. Current flows until the potential difference across gate-power capacitor 230 equals the threshold voltage of drive transistor 210, which causes the drive transistor to turn off. The resulting voltages are as shown in FIG. 4B. Then data lines 120 are connected to the responsive circuits, e.g. correlated double sampling circuits 290 by switch 285 (Step 450), and switch transistors 180 are turned on for the row of pixel drive circuits 200 by selecting the appropriate select line 130 (Step 460). The threshold-voltage-related signal is then measured by correlated double sampling circuit 290 (Step 470). The threshold voltage V_{th} is related to the threshold-voltage-related signal by Eq. 4 above. Using this equation, or a lookup table, processor 315 can calculate or find the threshold voltage and the adjustment to the signal voltage for each drive transistor 210 in the row of pixel drive circuits 200 and store one or both in memory 325 (Step 480). If there are more rows of pixel drive circuits 200 in OLED display 250 (Step 485), the process is repeated. If there are no more rows of pixel circuits, the determination of the threshold voltages is complete. Processor 315 can apply the adjustment to the signal voltage to digital-to-analog converter 280 to adjust the gate voltage on each drive transistor 210 to compensate for changes in the threshold voltage (Step 490). Step 490 need not follow immediately after Step 485. For example, Steps 410 to 485 can be done sequentially to all rows of pixel drive circuits 200 upon power-down

of OLED display 250 and the adjustments stored in memory. Step 490 can then be done to all pixel drive circuits 200 the next time the display is powered on.

Those skilled in the art will understand that other embodiments are possible. For example, after Step 440, the drive voltage can be set to another voltage, such as zero, by connecting ground 150 to power supply line 110 via switch 265, after which current flows again to reach the state shown in FIG. 4D. In this case, processor 315 can use Eq. 6 above to determine the threshold voltage and the adjustment to the signal voltage in Step 480.

PARTS LIST

100	pixel drive circuit
105	pixel drive circuit
110	power supply line
120	data line
130	select line
140	OLED light-emitting pixel
145	drain electrode
150	ground
155	source electrode
160	OLED light-emitting pixel
165	gate electrode
170	drive transistor
180	switch transistor
185	source or drain electrode
190	capacitor
195	gate electrode
200	pixel drive circuit
210	drive transistor
215	gate electrode
220	capacitor
230	capacitor
250	OLED display
260	voltage supply
265	switch
270	voltage supply
280	digital-to-analog converter
285	switch
290	correlated double sampling circuit

310 integrator
315 processor
320 low pass filter
325 memory
330 correlated double sampling unit
340 sample-and-hold element
350 analog-to-digital converter
410 block
420 block
430 block
440 block
450 block
460 block
470 block
480 block
485 decision block
490 block

CLAIMS:

1. An apparatus for determining an adjustment to a signal voltage for compensating for changes in the threshold voltage (V_{th}) for a drive transistor in a pixel drive circuit in an active matrix OLED display having at least one OLED light-emitting pixel, comprising:
- 5 one OLED light-emitting pixel, comprising:
- a) the pixel drive circuit having a data line, a power supply line, a drive transistor having source, drain, and gate electrodes, and a switch transistor having source, drain, and gate electrodes;
 - b) the source or drain electrode of the drive transistor being
10 electrically connected to the power supply line, and the other of the source or drain electrode being electrically connected to the OLED light-emitting pixel;
 - c) the source or the drain electrode of the switch transistor being electrically connected to the gate electrode of the drive transistor, and the other of the source or drain electrode being electrically connected to the data line;
 - 15 d) first means for applying a first voltage to the power supply line which is either positive or negative for causing current to flow in a first direction through the drive transistor which causes the OLED light-emitting pixel to produce light in response to the signal voltage;
 - e) second means for applying a second voltage to the power
20 supply line opposite in polarity to the first voltage so that current will flow through the drive transistor in a second direction opposite to the first direction until the potential on the gate electrode of the drive transistor causes the drive transistor to turn off;
 - f) third means for producing a threshold-voltage-related signal
25 on the data line which is a function of the potential on the gate electrode of the drive transistor; and
 - g) fourth means responsive to the threshold-voltage-related signal for calculating the adjustment to the signal voltage.

2. The apparatus of claim 1 wherein the OLED light-emitting pixel is a non-inverted OLED pixel and the first voltage is positive relative to a ground value.
3. The apparatus of claim 1 wherein the OLED light-emitting
5 pixel is an inverted OLED pixel and the first voltage is negative relative to a ground value.
4. The apparatus of claim 1 wherein the drive transistor and switch transistor are n-type transistors.
5. The apparatus of claim 1 wherein the drive transistor and
10 switch transistor are p-type transistors.
6. The apparatus of claim 1 wherein the fourth means includes a correlated double sampling circuit.
7. The apparatus of claim 1 wherein the fourth means includes an analog-to-digital converter and computation circuitry for calculating the
15 threshold voltage.
8. The apparatus of claim 1 wherein the fourth means further applies the adjustment to the signal voltage through the switch transistor of the pixel drive circuit to the gate electrode of the drive transistor of the pixel drive circuit during operation.

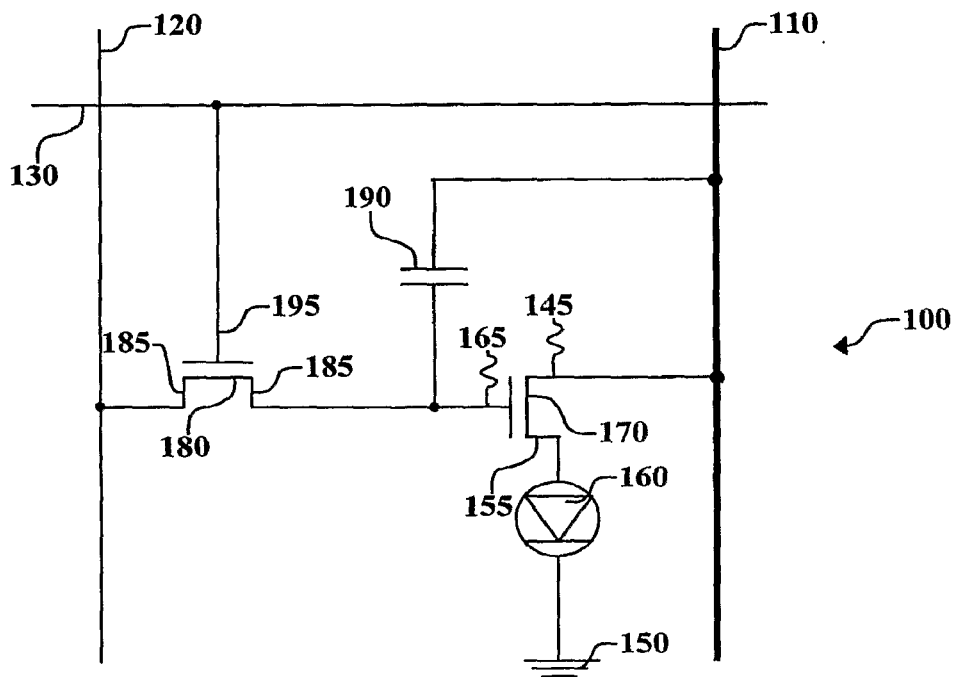

FIG. 1

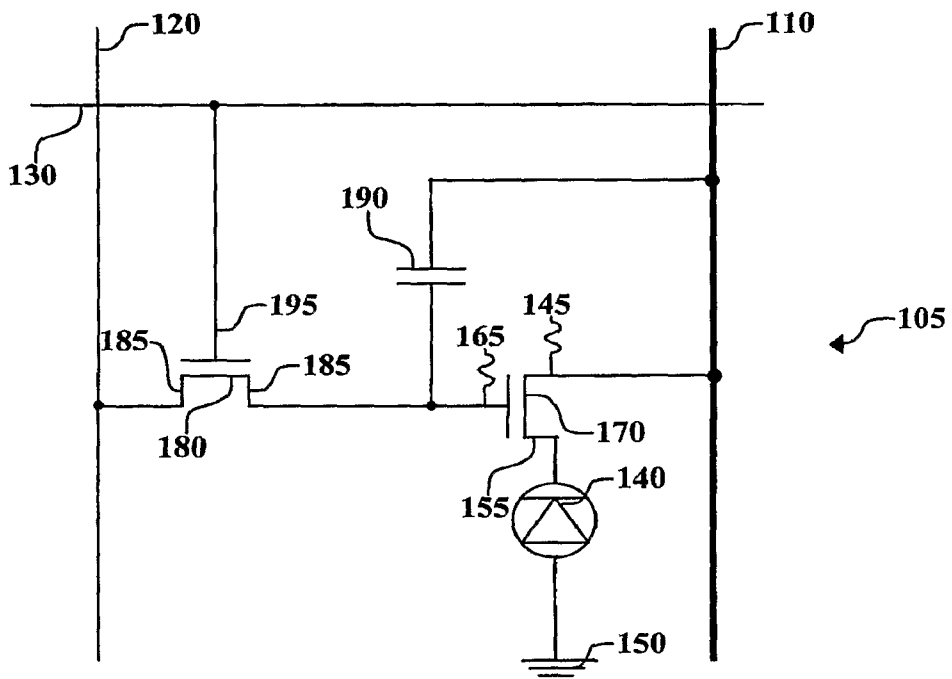

FIG. 2

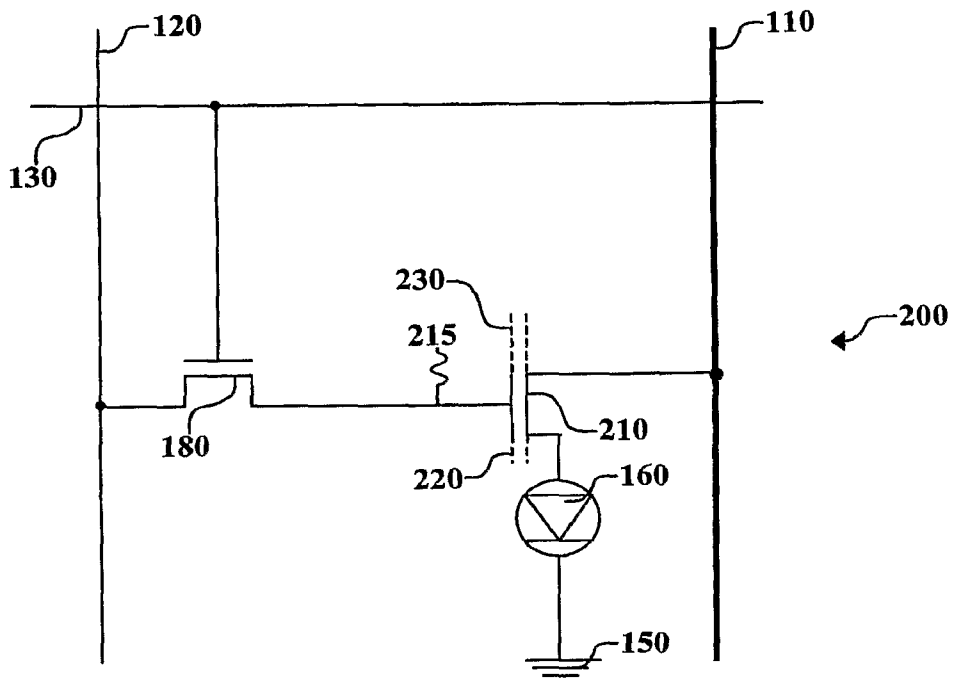

FIG. 3

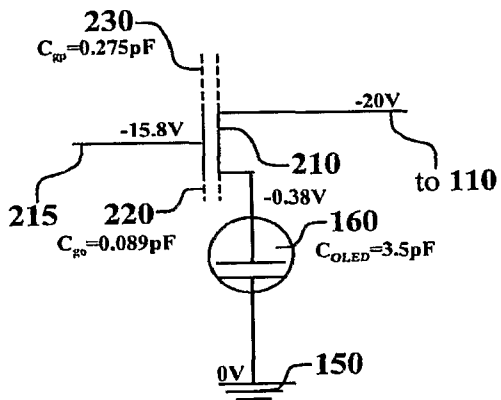

FIG. 4A

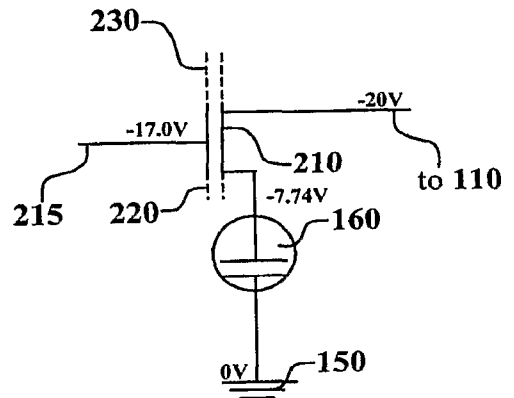

FIG. 4B

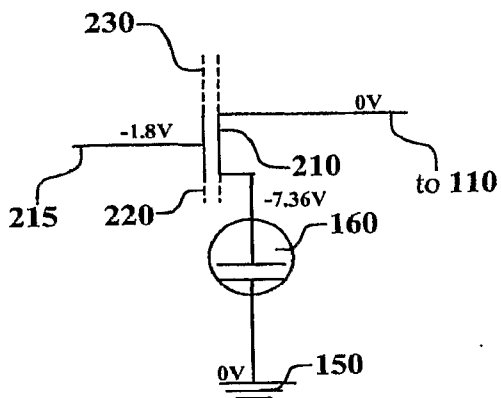

FIG. 4C

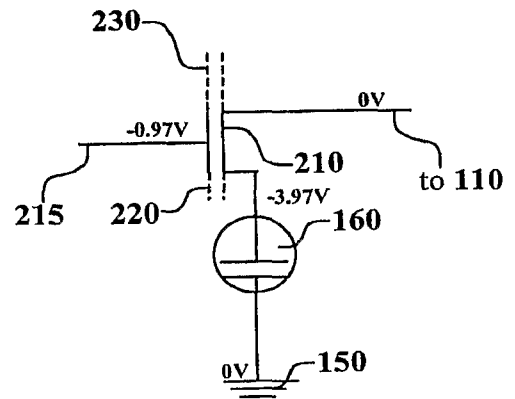

FIG. 4D

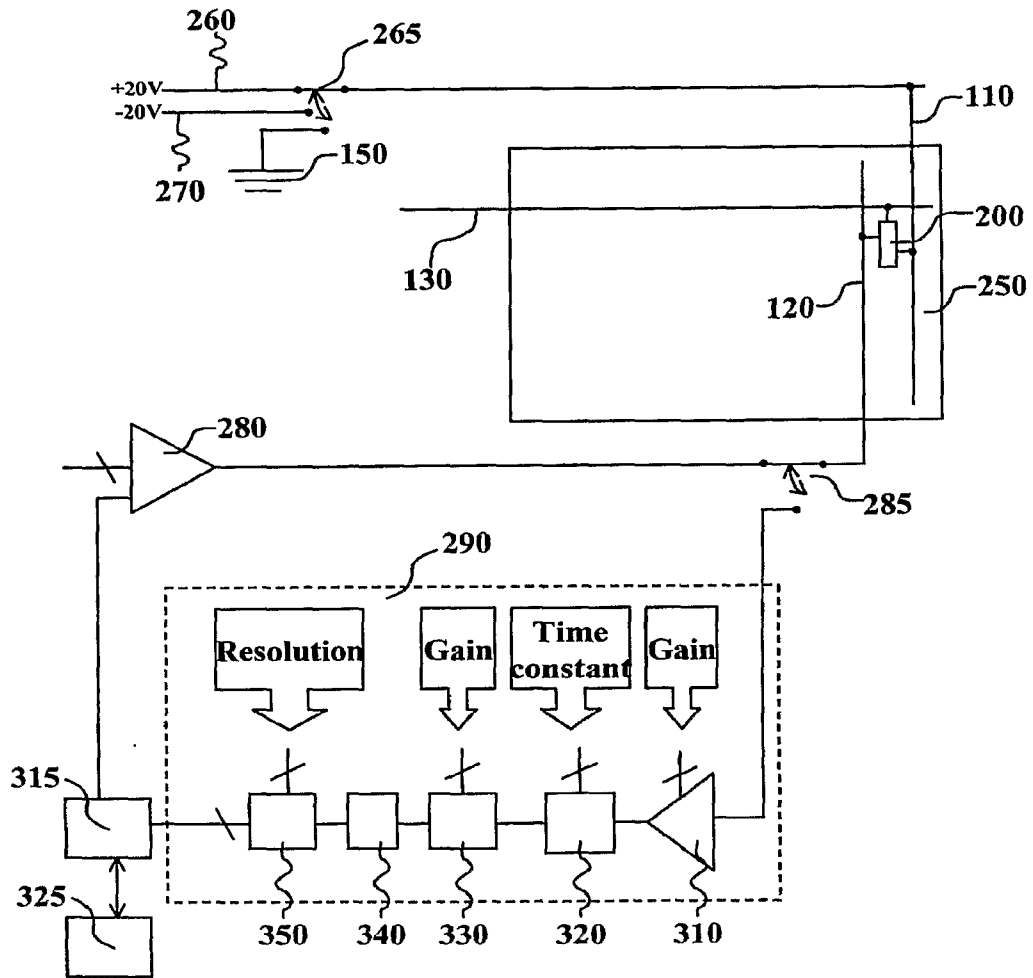

FIG. 5

6/6

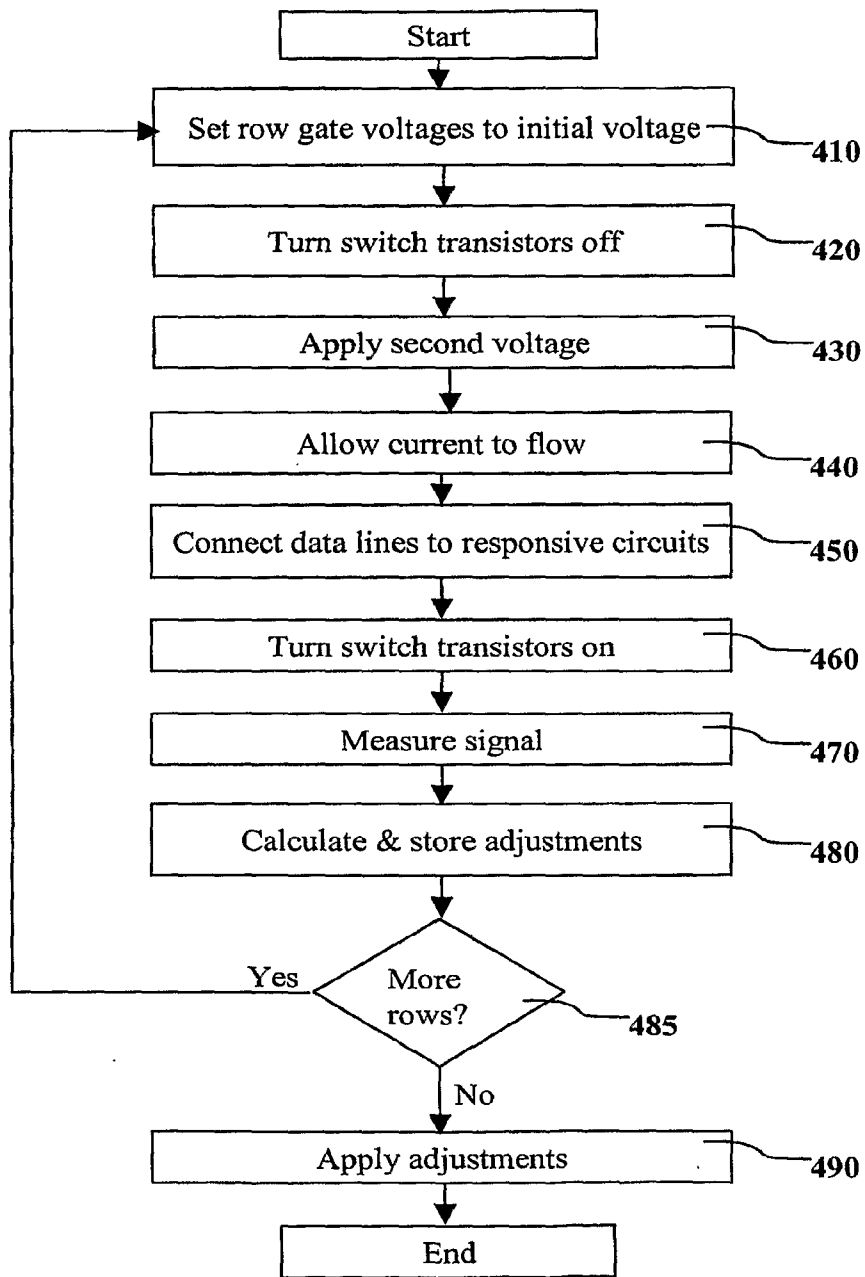

FIG. 6

专利名称(译)	有源矩阵显示补偿装置		
公开(公告)号	EP2033178A2	公开(公告)日	2009-03-11
申请号	EP2007809693	申请日	2007-06-20
[标]申请(专利权)人(译)	伊斯曼柯达公司		
申请(专利权)人(译)	伊士曼柯达公司		
当前申请(专利权)人(译)	全球OLED科技有限责任公司		
[标]发明人	HAMER JOHN WILLIAM PARRETT GARY		
发明人	HAMER, JOHN WILLIAM PARRETT, GARY		
IPC分类号	G09G3/32		
CPC分类号	G09G3/3233 G09G3/3291 G09G2300/0842 G09G2300/0866 G09G2310/0254 G09G2310/0256 G09G2320/0295 G09G2320/043		
优先权	11/427104 2006-06-28 US		
其他公开文献	EP2033178B1		
外部链接	Espacenet		

摘要(译)

一种用于确定对信号电压的调整的装置，用于补偿具有至少一个OLED发光像素的有源矩阵OLED显示器中的像素驱动电路中的驱动晶体管的阈值电压 (V_{th}) 的变化，包括：像素驱动电路，具有数据线，电源线，驱动晶体管；驱动晶体管电连接到电源线和OLED发光像素；开关晶体管电连接到驱动晶体管的栅极和数据线；第一种用于向电源线施加第一电压的装置；第二装置，用于向与第一电压极性相反的电源线施加第二电压；第三种方法，用于在数据线上产生与阈值电压相关的信号；第四装置响应于阈值电压相关信号，用于计算对信号电压的调节。