



(11) **EP 3 629 377 A1**

(12) **EUROPEAN PATENT APPLICATION**

(43) Date of publication:  
**01.04.2020 Bulletin 2020/14**

(51) Int Cl.:  
**H01L 27/32 (2006.01) H01L 51/52 (2006.01)**

(21) Application number: **19200291.3**

(22) Date of filing: **27.09.2019**

(84) Designated Contracting States:  
**AL AT BE BG CH CY CZ DE DK EE ES FI FR GB GR HR HU IE IS IT LI LT LU LV MC MK MT NL NO PL PT RO RS SE SI SK SM TR**  
Designated Extension States:  
**BA ME**  
Designated Validation States:  
**KH MA MD TN**

- **KIM, Wonrae**  
**10845 Paju-si Gyeonggi-do (KR)**
- **KIM, Sooin**  
**10845 Paju-si Gyeonggi-do (KR)**
- **KIM, Younghoon**  
**10845 Paju-si Gyeonggi-do (KR)**
- **YOON, Jungmin**  
**10845 Paju-si Gyeonggi-do (KR)**
- **KIM, Hyungyu**  
**10845 Paju-si Gyeonggi-do (KR)**

(30) Priority: **28.09.2018 KR 20180115629**

(71) Applicant: **LG Display Co., Ltd.**  
**SEOUL, 07336 (KR)**

(74) Representative: **Morrall, Jonathan Ian McLachlan**  
**Kilburn & Strode LLP**  
**Lacon London**  
**84 Theobalds Road**  
**London WC1X 8NL (GB)**

(72) Inventors:  
• **LEE, Seungbum**  
**10845 Paju-si Gyeonggi-do (KR)**

(54) **SELF LIGHT-EMITTING DISPLAY DEVICE**

(57) Disclosed herein is a self light-emitting display device. The self light-emitting display device includes a COT (a color filter (CF) on a thin film transistor) substrate, a passivation film (PAC) disposed above the COT substrate, a color conversion pattern (CCM) disposed above the passivation film and overlapped with a color filter pattern of the COT substrate, and a light-emitting layer (OG)

disposed above the passivation film and the color conversion pattern.

The light-emitting layer includes a flattening part (OGF) and a protruding part (OGP) which is disposed above the color conversion pattern and protrudes than the flattening part.

FIG. 2

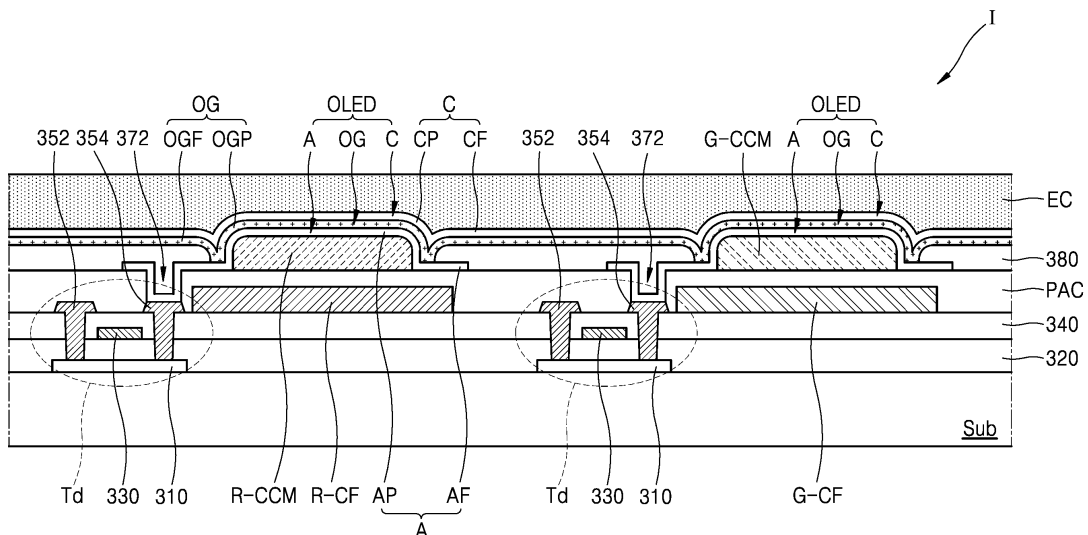

**EP 3 629 377 A1**

**Description**

## BACKGROUND

**Field of the Invention**

**[0001]** The present disclosure relates to a self light-emitting display device.

**Description of Related Art**

**[0002]** A display device is a device that can display data visually, such as in the form of an image. In today's information society, there is a growing need for various types of display devices that can display images. A liquid crystal display (LCD) device and an organic light-emitting diode (OLED) display device have been widely used as such display devices.

**[0003]** The organic light-emitting diode display device (which may also be termed an organic light-emitting device) displays an image using organic light-emitting diodes.

**[0004]** The organic light-emitting device is a self light-emitting display device that converts electrical energy into light energy using an organic material. In general, the organic light-emitting device has a structure in which an organic film is disposed between an anode and a cathode. When a driving voltage is supplied between the anode and the cathode, holes are injected through the anode and electrons are injected through the cathode. Thus, the holes and the electrons meet in the organic film and are coupled to each other. Accordingly, excitons are generated, and when the state of the excitons is turned into a floor state, light is emitted.

**[0005]** The organic film may have a structure in which layers include (and sometimes consist of) different materials are stacked to enhance efficiency and safety of the organic light-emitting device. For example, the organic film may include a hole injection layer, a hole transport layer, a light-emitting layer, an electron transport layer, an electron injection layer and the like.

**[0006]** A display device may include a color filter to display colors.

**[0007]** Such a color filter may be an optical component that transmits light in a range of predetermined color wavelengths among light coming from a light source and that absorbs light outside the range of predetermined color wavelengths. For example, the color filter may transmit light in a range of red wavelengths, light in a range of green wavelengths, and light in a range of blue wavelengths and may absorb light outside the ranges of red wavelengths, green wavelengths and blue wavelengths. Accordingly, the color filter may absorb light except for light in a range of predetermined color wavelengths to be displayed, thereby reducing light transmittance or luminous efficiency.

## SUMMARY OF THE INVENTION

**[0008]** Accordingly, the present disclosure is directed to a self light-emitting display device that substantially obviates one or more of the problems due to limitations and disadvantages of the related art.

**[0009]** The present disclosure provides a light-emitting display device that may enhance color conversion efficiency. The light-emitting display device may be a self light-emitting display device, for example an organic light-emitting display device.

**[0010]** The present disclosure also provides a self light-emitting display device that may enhance efficiency of external light extraction.

**[0011]** Problems that may be solved by the present disclosure are not limited to what has been described. Additionally, other problems that have not been mentioned may be clearly understood from the following description by one having ordinary skill in the art to which the disclosure pertains.

**[0012]** An invention is defined in the claims. examples disclosed herein provide a light-emitting display device or self light-emitting display device (e.g. organic light-emitting display device) that includes a substrate (e.g. COT (a color filter on a thin film transistor) substrate), a passivation film, a color conversion layer (e.g. color conversion pattern), and a light-emitting layer.

**[0013]** The substrate (e.g. COT substrate) includes a circuit board and a color filter layer (e.g. color filter pattern) that is disposed above the circuit board. The passivation film is disposed above the substrate, and the color conversion layer (e.g. color conversion pattern) is disposed above the passivation film and overlapped with the color filter pattern.

**[0014]** The light-emitting layer includes a flat part (e.g. flattening part) that is disposed above the passivation film, and a convex part that is disposed above the color conversion layer (e.g. color conversion pattern) and that protrudes with respect to the flat part (e.g. flattening part). The flat part (e.g. flattening part) and the convex part connect with each other.

**[0015]** Details of other examples and embodiments are included in the detailed description and the drawings.

**[0016]** In the self light-emitting display device according to the present disclosure, the color conversion pattern is disposed above a passivation film. Accordingly, the color conversion pattern may be designed as to be thick. As a result, color conversion efficiency may improve.

**[0017]** In the self light-emitting display device according to the present disclosure, the color conversion pattern may be formed after forming the contact hole in the passivation film. Accordingly, uniformity of contact holes of sub-pixels may improve. As a result, the self light-emitting display device may minimize decreasing electric feature of the anode which may be occurred by lack of uniformity of contact holes of sub-pixels.

**[0018]** In the self light-emitting display device according to the present disclosure, the sub-pixel may become

lens-shaped by tapered shape of the color conversion pattern. Thus, efficiency of external light extraction may be improved.

**[0019]** Effects of the present disclosure are not limited to the effects that have been described above. Additionally, various effects are included in the present disclosure.

#### BRIEF DESCRIPTION OF THE DRAWINGS

##### **[0020]**

FIG. 1 illustrates a self light-emitting display device according to the present disclosure.

FIG. 2 is a mimetic sectional view illustrating region I in FIG. 1.

FIG. 3 is a mimetic sectional view illustrating region II in FIG. 1.

FIG. 4 is a mimetic sectional view illustrating region III in FIG. 1.

#### DETAILED DESCRIPTION OF THE INVENTION

**[0021]** Advantages and features of the present disclosure, and methods for implementing the same may be understood clearly by reference to the following description of embodiments and experimental examples together with the attached drawings. The attached drawings are provided so that the technical spirit of the present disclosure can be readily understood. Therefore, the technical spirit should not be construed as being limited to the attached drawings.

**[0022]** Additionally, the inventive subject matter may be embodied in various different forms. Accordingly, the disclosure should not be construed as being limited to what is disclosed below. Rather, what is disclosed below is presented so that the disclosure can be thorough and complete and can fully convey the scope of the inventive subject matter to one having ordinary skill in the art. The present disclosure should be defined only according to the scope of the appended claims.

**[0023]** Detailed description of relevant technologies that are publicly known may be omitted if it is deemed to make the gist of the present disclosure unnecessarily vague.

**[0024]** The terms "first", "second" and the like are used herein to describe various elements. However, the terms are used only to distinguish one element from another element. Thus, the elements should not be limited by the terms. Unless otherwise described, a first element may be a second element.

**[0025]** Throughout the specification, the singular forms "a", "an" and "the" are intended to include the plural forms as well, unless otherwise described.

**[0026]** Throughout the specification, the terms "including", and "having" should imply the inclusion of any other element but not the exclusion of any other element, unless otherwise described.

**[0027]** Throughout the specification, the terms "A and/or B" imply A, B, or A and B, and the terms "C to D" imply C or more and D or less, unless otherwise described.

**[0028]** When an element or a layer is referred to as being "on" another element or "on" another layer, an element or a layer may be "directly on" or "right on" another element or another layer, and a third element or a third layer may be interposed between an element and another element or between a layer and another layer. However, when an element or a layer is referred to as being "directly on" another element or another layer, or being "right on" another element or another layer, a third element or a third layer is not interposed between an element and another element or between a layer and another layer.

**[0029]** Special terms such as "below", "beneath", "lower", "above", "upper" and the like may be used to readily describe a relationship between one element or elements and another element or elements, as illustrated in the drawings. Additionally, the special terms should be interpreted as including different directions in which the elements are used or operate in addition to the directions in the drawings. In the context of a device that is manufactured on a substrate (Sub), if a first layer or component is "above" or "upper" or "higher" relative to a second layer or component, then the second layer or component is positioned between the first layer or component and the substrate. Similarly, if a first layer or component is "below" or "lower" or "beneath" relative to a second layer or component, then the first layer or component is positioned between the second layer or component and the substrate.

**[0030]** Below, the present disclosure is described with reference to the attached drawings.

**[0031]** FIG. 1 is a mimetic view illustrating a self light-emitting display device 1000 according to the present disclosure.

**[0032]** The self light-emitting display device 1000 includes a display area in which each of the pixels is arranged in a matrix form, and a non-display area that is disposed around the display area. The display area is an area in which an image or information, generated in the self light-emitting display device 1000, is visible to a viewer. The non-display area is an area in which an image or information, generated in the self light-emitting display device 1000, is not visible to a viewer and is generally referred to as a bezel area. The self light-emitting display device 1000 includes a plurality of pixels. FIG. 1 illustrates a single pixel among a plurality of pixels that are provided in the self light-emitting display device 1000.

**[0033]** A pixel may be divided into sub-pixels. The sub-pixels may be classified into a first sub-pixel, a second sub-pixel, a third sub-pixel, and a fourth sub-pixel. For example, the first sub-pixel may be a red pixel, the second sub-pixel may be a green pixel, the third sub-pixel may be a blue pixel, and the fourth sub-pixel may be a white pixel.

**[0034]** The self light-emitting display device 1000 includes an upper encapsulation layer (EC), an organic light-emitting device (OLED) and a lower substrate, for each pixel. The organic light-emitting device (OLED) is disposed between the upper encapsulation layer (EC) and the lower substrate. The lower substrate includes a COT (a color filter on a thin film transistor) substrate, a passivation film (PAC) that is disposed above the COT substrate and a color conversion pattern.

**[0035]** The COT substrate includes a circuit board and a color filter pattern that is disposed above the circuit board. The circuit board includes a substrate (Sub) and a thin-film transistor array (TFT Array) that is disposed above the substrate (Sub). The color filter pattern is disposed above the thin-film transistor array (TFT Array). The passivation film (PAC) is disposed above the COT substrate and is disposed between the organic light-emitting device (OLED) and the COT substrate. The color conversion pattern is disposed above the passivation film (PAC) and overlapped with the color filter pattern.

**[0036]** The color filter pattern includes a first color filter unit (R-CF), a second color filter unit (G-CF), a third color filter unit (B-CF), and a fourth color filter unit (W-CF). For example, the first color filter unit (R-CF) may be a red filter unit that is disposed in a red pixel, the second color filter unit (G-CF) may be a green filter unit that is disposed in a green pixel, the third color filter unit (B-CF) may be a blue filter unit that is disposed in a blue pixel, and the fourth color filter unit (W-CF) may be a white filter unit that is disposed in a white pixel.

**[0037]** On the assumption that the first color filter unit (R-CF) is a red filter unit that is disposed in a red pixel, that the second color filter unit (G-CF) is a green filter unit that is disposed in a green pixel, and that the third color filter unit (B-CF) is a blue filter unit that is disposed in a blue pixel, the first color filter unit (R-CF), the second color filter unit (G-CF), and the third color filter unit (B-CF) are described below.

**[0038]** The first color filter unit (R-CF) only transmits light in a range of red wavelengths and for example, absorbs light in ranges of green wavelengths and blue wavelengths. The first color filter unit (R-CF) includes pigment red. Pigment red is not restricted. For example, pigment red may be C.I. pigment red 177, C.I. pigment red 254, C.I. pigment red 7, C.I. pigment red 9, C.I. pigment red 14, C.I. pigment red 41, C.I. pigment red 81, C.I. pigment red 97, C.I. pigment red 122, C.I. pigment red 123, C.I. pigment red 146, C.I. pigment red 149, C.I. pigment red 155, C.I. pigment red 166, C.I. pigment red 168, C.I. pigment red 169, C.I. pigment red 176, C.I. pigment red 178, C.I. pigment red 180, C.I. pigment red 184, C.I. pigment red 185, C.I. pigment red 187, C.I. pigment red 192, C.I. pigment red 200, C.I. pigment red 220, C.I. pigment red 223, C.I. pigment red 224, C.I. pigment red 226, C.I. pigment red 227, C.I. pigment red 228, C.I. pigment red 240, C.I. pigment red 242, C.I. pigment red 246, C.I. pigment red 255, C.I. pigment red 264, C.I. pigment red 270, C.I. pigment red 272, C.I. pigment red 273, C.I.

pigment red 276, or C.I. pigment red 277 and the like.

**[0039]** The second color filter unit (G-CF) only transmits light in a range of green wavelengths and for example, absorbs light in ranges of red wavelengths and blue wavelengths. The second color filter unit (G-CF) includes pigment green. Pigment green is not restricted. For example, pigment green may be a phthalocyanine-based compound such as C.I. pigment green 7, or C.I. pigment green PG36 and the like.

**[0040]** The third color filter unit (B-CF) only transmits light in a range of blue wavelengths and for example, absorbs light in ranges of red wavelengths and green wavelengths. The third color filter unit (B-CF) includes pigment blue. Pigment blue is not restricted. For example, pigment blue may be C.I. pigment blue 15, C.I. pigment blue 15:1, C.I. pigment blue 15:2, C.I. pigment blue 15:3, C.I. pigment blue 15:4, C.I. pigment blue 15:6, C.I. pigment blue 16, C.I. pigment blue 22, C.I. pigment blue 60, or C.I. pigment blue 64 and the like.

**[0041]** The passivation film (PAC) may flatten a surface of the COT substrate and may include first parts that are disposed above the color filter pattern, and second parts that are disposed above the thin-film transistor array (TFT Array). The passivation film (PAC) is a single film. The first parts may connect with the second parts, and at least one of the first parts may be disposed between the second parts.

**[0042]** The color conversion pattern is disposed above the passivation film (PAC). Specifically, the color conversion pattern may consist of a first color conversion unit (R-CCM) that is disposed to be overlapped with the first color filter unit (R-CF), and a second color conversion unit (G-CCM) that is disposed to be overlapped with the second color filter unit (G-CF). For example, the first color conversion unit (R-CCM) may be a red conversion unit that is disposed in a red pixel and that converts input light into light in a range of red wavelengths, i.e., red light, and the second color conversion unit (G-CCM) may be a green conversion unit that converts input light into light in a range of green wavelengths, i.e., green light.

**[0043]** The first color conversion unit (R-CCM) and the second color conversion unit (G-CCM) include color conversion materials. The color conversion materials, for example, may be quantum dots, fluorescent dyes or a combination thereof. The fluorescent dyes, for example, include organic fluorescent materials, inorganic fluorescent materials, and a combination thereof.

**[0044]** The quantum dot may be selected from II-VI compounds, III-V compounds, IV-VI compounds, IV elements, IV compounds and a combination thereof but not restricted. II-VI compounds may be selected from a group consisting of a binary compound that is selected from a group consisting of CdSe, CdTe, ZnS, ZnSe, ZnTe, ZnO, HgS, HgSe, HgTe, MgSe, MgS, and a combination thereof; a ternary compound that is selected from a group consisting of CdSeS, CdSeTe, CdSTe, ZnSeS, ZnSeTe, ZnSTe, HgSeS, HgSeTe, HgSTe, CdZnS, CdZnSe, CdZnTe, CdHgS, CdHgSe, CdHgTe, HgZnS, HgZnSe,

HgZnTe, MgZnSe, MgZnS, and a combination thereof; and a quaternary compound that is selected from a group consisting of HgZnTeS, CdZnSeS, CdZnSeTe, CdZnSTe, CdHgSeS, CdHgSeTe, CdHgSTe, HgZnSeS, HgZnSeTe, HgZnSTe, and a combination thereof. III-V compounds may be selected from a group consisting of a binary compound that is selected from a group consisting of GaN, GaP, GaAs, GaSb, AlN, AlP, AlAs, AlSb, InN, InP, InAs, InSb, and a combination thereof; a ternary compound that is selected from a group consisting of GaNP, GaNAs, GaNSb, GaPAs, GaPSb, AINP, AINAs, AINSb, AIPAs, AIPs, InNP, InNAs, InNSb, InPAs, InPSb, GaAInP, and a combination thereof; and a quaternary compound that is selected from a group consisting of GaAInAs, GaAInSb, GaAIPAs, GaAIPs, GaInNP, GaInNAs, GaInNSb, GaInPAs, GaInPSb, InAInP, InAInAs, InAInSb, InAIPAs, InAIPs, and a combination thereof. IV-VI compounds may be selected from a group consisting of a binary compound that is selected from a group consisting of SnS, SnSe, SnTe, PbS, PbSe, PbTe, and a combination thereof; a ternary compound that is selected from a group consisting of SnSeS, SnSeTe, SnSTe, PbSeS, PbSeTe, PbSTe, SnPbS, SnPbSe, SnPbTe, and a combination thereof; and a quaternary compound that is selected from a group consisting of SnPbSSe, SnPbSeTe, SnPbSTe, and a combination thereof. IV elements may be selected from a group consisting of Si, Ge, and a combination thereof. IV compounds may be a binary compound that is selected from a group consisting of SiC, SiGe, and a combination thereof.

**[0045]** In this case, a particle may include a uniform concentration of the binary compound, the ternary compound, or the quaternary compound, or may include a different concentration of the binary compound, the ternary compound, or the quaternary compound. The Quantum dot may have a core/shell structure in which one quantum dot encircles another quantum dot. Interfaces of the core and shell may have a concentration gradient in which a concentration of elements becomes lower from the shell toward the core.

**[0046]** The quantum dot may have full width at half maximum (FWHM) of an emission spectrum, which is about 45nm or less, preferably, about 40nm or less and more preferably, about 30nm or less. In this range, color purity or color reproduction may improve. Additionally, light that is emitted through the quantum dot is released in whole directions. Accordingly, a range of light viewing angles may be expanded.

**[0047]** Further, types of quantum dots are not restricted. For example, the quantum dots may be any one of spherical quantum dots, pyramid-shaped quantum dots, and multi-arm quantum dots, or may be any one of cube-shaped nano particles, nano tube-shaped particles, nano wire-shaped particles, nano fiber-shaped particles, nano plate-shaped particles.

**[0048]** The fluorescent dyes, for example, may be red fluorescent dyes, green fluorescent dyes, dyes that emit

a third color light, or a combination thereof. The red fluorescent dyes are a material that absorbs light in a range of green wavelengths and that emits light in a range of red wavelengths. The red fluorescent dyes, for example, may be at least one of (Ca, Sr, Ba)S, (Ca, Sr, Ba)<sub>2</sub>SisNs, CaAlSiN<sub>3</sub>, CaMoO<sub>4</sub>, Eu<sub>2</sub>Si<sub>5</sub>N<sub>8</sub>. The green fluorescent dyes are a material that absorbs light in a range of blue wavelengths and that emits light in a range of green wavelengths. The green fluorescent dyes, for example, may be at least one of yttrium aluminum garnet (YAG), (Ca, Sr, Ba)<sub>2</sub>SiO<sub>4</sub>, SrGa<sub>2</sub>S<sub>4</sub>, barium magnesium aluminate (BMA), α-SiAlON, β-SiAlON, Ca<sub>3</sub>Sc<sub>2</sub>Si<sub>3</sub>O<sub>12</sub>, Tb<sub>3</sub>Al<sub>5</sub>O<sub>12</sub>, BaSiO<sub>4</sub>, CaAlSiON, (Sr<sub>1-x</sub>Ba<sub>x</sub>)Si<sub>2</sub>O<sub>2</sub>N<sub>2</sub>.

**[0049]** The organic light-emitting device (OLED) is disposed above the lower substrate and specifically, may consist of a partial region that is disposed above the color conversion pattern and another partial region that is disposed above the passivation film (PAC). The upper encapsulation layer (EC) is disposed above the organic light-emitting device (OLED). The upper encapsulation layer (EC) may be disposed above the organic light-emitting device (OLED), may prevent external moisture or external air and the like from coming into the organic light-emitting device (OLED) and may protect the organic light-emitting device (OLED) from external impact.

**[0050]** The organic light-emitting device (OLED) outputs white light (W). The color conversion pattern converts short-wavelength light among input white light into long-wavelength light and outputs the long-wavelength light. The long-wavelength light that is output from the color conversion pattern is input to the color filter pattern, and the color filter pattern only transmits light in a range of specific wavelengths among the input light optionally and absorbs light outside the range of specific wavelengths. The self light-emitting display device 1000 may implement colors using light that passes through the color filter pattern.

**[0051]** In a red pixel, white light (W) may be output as red light (R) in the self light-emitting display device 1000 via the first color conversion unit (R-CCM), the passivation film (PAC), and the red filter unit (R-CF) in order. In a green pixel, white light (W) may be output as green light (G) in the self light-emitting display device 1000 via the second color conversion unit (G-CCM), the passivation film (PAC), and the green filter unit (G-CF) in order. In a blue pixel, white light (W) may be output as blue light (B) in the self light-emitting display device 1000 via the passivation film (PAC) and the third color filter unit (B-CF). In a white pixel, white light (W) may be output as white light (W) in the self light-emitting display device 1000 via the passivation film (PAC) and the fourth color filter unit (W-CF).

**[0052]** The first color conversion unit (R-CCM) converts a part of input white light (W) into red light (R) and outputs the red light (R) to the first color filter unit (R-CF), and the first color filter unit (R-CF) only transmits red light (R) among input light. Accordingly, the self light-emitting display device 1000 may implement a red color. The sec-

ond color conversion unit (G-CCM) converts a part of input white light (W) into green light (G) and outputs the green light (G) to the second color filter unit (G-CF), and the second color filter unit (G-CF) only transmits green light (G) among input light. Accordingly, the self light-emitting display device 1000 may implement a green color.

**[0053]** The third color filter unit (B-CF) only transmits blue light (B) among input white light (W). Accordingly, the self light-emitting display device 1000 may implement a blue color. The fourth color filter unit (W-CF) transmits input white light (W).

**[0054]** FIG. 2 is a mimetic sectional view illustrating region I in FIG. 1.

**[0055]** An organic light-emitting device (OLED) electrically connects with a driving thin-film transistor (Td) and emits light. The organic light-emitting device (OLED) includes an anode (A), a cathode (C), and an organic film (OG). The organic film (OG) is disposed between the anode (A) and the cathode (C).

**[0056]** A first color filter unit (R-CF) and a second color filter unit (G-CF) are disposed above a circuit board, and a passivation film (PAC) is disposed above a COT (a color filter on a thin film transistor) substrate. A first color conversion unit (R-CCM) and a second color conversion unit (G-CCM) are disposed above the passivation film (PAC). The first color conversion unit (R-CCM) is disposed to be overlapped with the first color filter unit (R-CF), and the second color conversion unit (G-CCM) is disposed to be overlapped with the second color filter unit (G-CF).

**[0057]** First parts of the passivation film (PAC) are interposed between the first color conversion unit (R-CCM) and the first color filter unit (R-CF), and between the second color conversion unit (G-CCM) and the second color filter unit (G-CF). The passivation film (PAC) may also include second parts disposed above the driving thin-film transistor (Td). A contact hole 372 may be provided in the second parts of the passivation film (PAC).

**[0058]** In the red pixel, the anode (A) may include a first part (AF) that is disposed above the passivation film (PAC), and a second part (AP) that is disposed above the first color conversion unit (R-CCM). The first part (AF) of the anode (A) may electrically connect with the driving thin-film transistor (Td) through the contact hole 372. The second part (AP) of the anode (A) is formed along a surface of the first color conversion unit (R-CCM) and protrudes convexly with respect to the first part (AF).

**[0059]** In the green pixel, the anode (A) may include a first part (AF) that is disposed above the passivation film (PAC), and a second part (AP) that is disposed above the second color conversion unit (G-CCM). The first part (AF) of the anode (A) may electrically connect with the driving thin-film transistor (Td) through the contact hole 372. The second part (AP) of the anode (A) is formed along a surface of the second color conversion unit (G-CCM) and protrudes convexly with respect to the first part (AF).

**[0060]** A pixel defining film 380 may be configured to divide pixels. The pixel defining film 380 may be disposed above the passivation film (PAC). Further, the pixel defining film 380 may be disposed above the first part (AF) of the anode (A) and covers the driving thin-film transistor (Td). A flattening part (OGF) of the organic film (OG) may be disposed above the pixel defining film 380. The pixel defining film 380 covers edge of the anode (A). In other words, the pixel defining film 380 may be patterned so that a part of the anode (A) can be exposed, and the organic film (OG) may be disposed in a part of the pixel defining film 380 that is patterned so that a part of the anode (A) can be exposed.

**[0061]** In the red pixel and the green pixel, the organic film (OG) and the cathode (C) that are orderly disposed above the anode (A) have a flattening part (OGF, CF) and a convex part (OGP, CP) that protrudes convexly with respect to the flattening part (OGF, CF) respectively. The convex parts (OGP, CP) of the organic film (OG) and the cathode (C) are formed along a surface of the second part (AP) of the anode (A). The flattening part (OGF) of the organic film (OG), and the flattening part (CF) of the cathode (C) are orderly formed above the pixel defining film 380. The convex part (OGP) of the organic film (OG), and the convex part (CP) of the cathode (C) are orderly formed above the second part (AP) of the anode (A). A part of the flattening part (OGF) of the organic film (OG), and a part of the flattening part (CF) of the cathode (C) may be overlapped with the second parts of the passivation film (PAC).

**[0062]** The self light-emitting display device 1000 has a bottom emission-type structure in which an image is implemented in a direction of the anode (A). The anode (A) may consist of light-transmitting electrodes, and the cathode (C) may consist of reflective electrodes. The light-transmitting electrodes, for example, may consist of light-transmitting metal oxides such as ITO, IZO, ZnO and the like, and the reflective electrodes, for example, may consist of metal such as Ag, Mg, Al, Pt, Pd, Au, Ni, Nd, Ir, Cr, Li, Ca and the like.

**[0063]** The organic film (OG) includes a hole transport layer (not shown), a light-emitting layer (not shown), and an electron transport layer (not shown). The hole transport layer (not shown) is disposed between the anode (A) and the light-emitting layer (not shown), the light-emitting layer (not shown) is disposed between the hole transport layer (not shown) and the electron transport layer (not shown), and the electron transport layer (not shown) is disposed between the light-emitting layer (not shown) and the cathode (C). The organic film (OG) may further include a hole injection layer (not shown). In this case, the hole injection layer (not shown) may be disposed between the anode (A) and the hole transport layer (not shown). The organic film (OG) may further include an electron injection layer (not shown). In this case, the electron injection layer (not shown) may be disposed between the electron transport layer (not shown) and the cathode (C).

**[0064]** The hole injection layer (not shown) may allow holes to be smoothly injected from the anode (A) into the light-emitting layer (not shown), and for example, may include at least one of HAT-CN, CuPu(copper phthalocyanine), PEDOT(poly(3,4)-ethylenedioxythiophene), PEDOT: PSS(poly(3,4)-ethylenedioxythiophene poly(styrenesulfonate)), PANI(polyaniline), and NPD(N,N-dinaphthyl-N,N'-diphenyl benzidine).

**[0065]** The hole transport layer (not shown) may allow the holes to be smoothly transported, and for example, may include at least one of NPD(N,N-dinaphthyl-N,N'-diphenylbenzidine), TPD(N,N'-bis-(3-methylphenyl)-N,N'-bis-(phenyl)-benzidine), s-TAD and MTDA-TA(4,4',4"-Tris(N-3-methylphenyl-N-phenyl-amino)-triphenylamine).

**[0066]** The light-emitting layer (not shown) may have a structure in which a red light-emitting layer (not shown), a green light-emitting layer (not shown), and a blue light-emitting layer (not shown) are stacked, or a structure in which a blue light-emitting layer (not shown), and a yellowish green light-emitting layer (not shown) are stacked, and may emit white light.

**[0067]** The electron transport layer (not shown) may allow electrons to be smoothly transported, and for example, may include at least one of Alq3(tris(8-hydroxyquinolino)aluminum), PBD, TAZ, spiro-PBD, BALq and SALq.

**[0068]** The electron injection layer (not shown) may allow the electrons to be smoothly injected, and for example, may include at least one of Alq3(tris(8-hydroxyquinolino)aluminum), PBD, TAZ, spiro-PBD, BALq and SALq.

**[0069]** A circuit board includes the driving thin-film transistor (Td) that is disposed above the substrate (Sub). Though not illustrated, in the circuit board, a switching thin-film transistor (not shown) and the like may be further disposed above the substrate (Sub). The substrate (Sub) is a transparent substrate and may be a glass substrate, a transparent polymer resin substrate and the like that are usually used. A buffer layer (not shown) may be optionally interposed between the substrate (Sub) and the driving thin-film transistor (Td) to improve flatness of the substrate (Sub). The buffer layer (not shown) may consist of inorganic oxides such as a silicon oxide and the like, inorganic nitrides such as a silicon nitride and the like, and the like.

**[0070]** The driving thin-film transistor (Td) is disposed above the substrate (Sub) and includes a semiconductor layer 310, a first insulation film 320, a gate electrode 330, a second insulation film 340, a source electrode 352, and a drain electrode 354.

**[0071]** The semiconductor layer 310 is disposed above a first region of the substrate (Sub). The semiconductor layer 310, for example, may consist of an oxide semiconductor material or may consist of polycrystalline silicon. When the semiconductor layer 310 consists of polycrystalline silicon, the semiconductor layer 310 may include an active layer (not shown) and channel regions (not

shown) that are disposed on both side of the active layer.

**[0072]** The first insulation film 320 is disposed between the gate electrode 330 and the substrate (Sub). A part of the first insulation film 320 is disposed above the semiconductor layer 310 in the first region of the substrate (Sub), and another part of the first insulation film 320 is disposed above a second region of the substrate (Sub). The first region of the substrate (Sub) and the second region of the substrate (Sub) are independent regions. In this specification, the first region of the substrate (Sub) may be defined as a region in which the semiconductor layer 310 is formed. The first insulation film 320 may consist of inorganic oxides such as a silicon oxide and the like, inorganic nitrides such as a silicon nitride and the like, and the like.

**[0073]** The gate electrode 330 is disposed above the first insulation film 320, and is disposed to be overlapped with the semiconductor layer 310 in the first region of the substrate (Sub). The gate electrode 330 may consist of aluminum-based metal such as aluminum (Al), aluminum alloys and the like, silver-based metal such as silver (Ag), silver alloys and the like, copper-based metal such as copper (Cu), copper alloys and the like, molybdenum-based metal such as molybdenum (Mo), molybdenum alloys and the like, chromium (Cr), titanium (Ti), tantalum (Ta) and the like.

**[0074]** The second insulation film 340 is disposed above the first insulation film 320 and the gate electrode 330. Specifically, a part of the second insulation film 340 is disposed above the first insulation film 320, and another part of the second insulation film 340 is disposed above the gate electrode 330. Like the first insulation film 320, the second insulation film 340 may consist of inorganic oxides such as a silicon oxide and the like, inorganic nitrides such as a silicon nitride and the like, and the like.

**[0075]** The source electrode 352, the drain electrode 354, the first color filter unit (R-CF), and the second color filter unit (G-CF) are disposed above the second insulation film 340. The source electrode 352 and the drain electrode 354 are spaced apart from each other in the second insulation film 340 in each of the red pixel and the green pixel. In the red pixel, the first color filter unit (R-CF) may be disposed above the second insulation film 340 so as to be overlapped with the first color conversion unit (R-CCM) and is spaced from the source electrode 352 and the drain electrode 354. In the green pixel, the second color filter unit (G-CF) may be disposed above the second insulation film 340 so as to be overlapped with the second color conversion unit (G-CCM) and is spaced from the source electrode 352 and the drain electrode 354.

**[0076]** The source electrode 352 and the drain electrode 354 connect with the semiconductor layer 310 through the contact holes that are provided in the first insulation film 320 and the second insulation film 340. The source electrode 352 and the drain electrode 354 may consist of metal such as Al, Ag, Mg, Mo, Ti or W and

the like.

**[0077]** An upper encapsulation layer (EC) is disposed above the cathode (C), and may prevent external moisture or external air and the like from coming into the organic film (OG) and protect the organic film (OG) from an external impact.

**[0078]** FIG. 3 is a mimetic sectional view illustrating region II in FIG. 1, and FIG. 4 is a mimetic sectional view illustrating region III in FIG. 1. What has been described with reference to FIG. 2 is omitted, hereunder. Region II in FIG. 3 mimetically illustrates a green pixel and a blue pixel, and region III in FIG. 4 mimetically illustrates a blue pixel and a white pixel.

**[0079]** Unlike the red pixel and the green pixel, the blue pixel and the white pixel do not include a color conversion pattern that is disposed above the passivation film (PAC) to be overlapped with the third color filter unit (B-CF) and the fourth color filter (W-CF).

**[0080]** Unlike the anode (A) of each of the red pixel and the green pixel, the anode (A) of each of the blue pixel and the white pixel consists only of a first part (AF) that is a flattening part disposed above the passivation film (PAC) That is, the anode (A) of each of the blue pixel and the white pixel does not include a second part (AP) that protrudes convexly relative to the first part (AF).

**[0081]** Unlike the organic film (OG) of the red pixel and the green pixel, the organic film (OG) of the blue pixel and the white pixel includes a flattening part (OGF) that is disposed above the pixel defining film 380 and a concave part (OGC) that is disposed above the anode (A) so as to be dug concavely relative to the flattening part (OGF). That is, the organic film (OG) of each of the blue pixel and the white pixel does not include a convex part (OGP) that protrudes convexly relative to the flattening part (OGF).

**[0082]** Unlike the cathode (C) of the red pixel and the green pixel, the cathode (C) of the blue pixel and the white pixel consists of a flattening part (CF) and a concave part (CC) that is dug concavely relative to the flattening part (CF). That is, the cathode (C) of each of the blue pixel and the white pixel does not include a convex part (CP) that protrudes convexly relative to the flattening part (CF).

**[0083]** In a structure including the color conversion pattern directly disposed on the color filter pattern and covered by the passivation film, difference between heights of WRGB sub-pixels may increase, and thus the uniformity of contact holes of the passivation film (PAC) may be decreased. As a result, lack of electric feature of the anode may be occurred.

**[0084]** In the self light-emitting display device 1000 according to the present disclosure, a contact hole is formed in the passivation film (PAC), and then a color conversion pattern is formed. Thus, lack of uniformity of contact holes among sub-pixels may be prevented. Additionally, in the self light-emitting display device 1000, a color conversion pattern is disposed above the passivation film (PAC). Accordingly, a thick color conversion pattern may be de-

signed. As a result, unlike the above-described structure, the structure of the self light-emitting display device 1000 may lead to an increase in efficiency of color conversion.

**[0085]** Further, in the self light-emitting display device 1000, the sub-pixel may become lens-shaped by tapered shape of the color conversion units (R-CCM, G-CCM). Accordingly, the self light-emitting display device 1000 may improve efficiency of external light extraction. Specifically, in the self light-emitting display device 1000, the anode (A) may include taper shaped surface corresponding to the tapered shape of the color conversion units (R-CCM, G-CCM). Accordingly, a path of light changes on the taper shaped surface of the anode (A). As a result, light that is lost as isolated light in the organic film (OG) may be extracted outwards in wave-guided mode because of a difference in the refractive indices of the anode (A) and the organic film (OG).

**[0086]** Furthermore, the self light-emitting display device 1000 may prevent that light reflected from the taper shaped surface of the cathode (C) leaks through lateral surfaces, by the color conversion units (R-CCM, G-CCM), and thus may concentrate light on the front surface.

**[0087]** Also disclosed herein are a examples according to the following numbered clauses:

Clause 1. A self light-emitting display device, comprising:

30 a COT (a color filter on a thin film transistor) substrate including a circuit board and a color filter pattern disposed above the circuit board, wherein the circuit board includes a driving thin-film transistor;

35 a passivation film disposed above the COT substrate;

a color conversion pattern disposed above the passivation film and overlapped with the color filter pattern; and

40 a light-emitting layer disposed above the passivation film and the color conversion pattern, the light emitting layer including a flattening part and a convex part which is disposed above the color conversion pattern and protrudes convexly than the flattening part.

Clause 2. The self light-emitting display device of clause 1, further comprising:

50 an anode including a first part disposed between the flattening part and the passivation film, and a second part disposed between the color conversion pattern and the convex part, wherein the second part protrudes convexly than the first part,

55 wherein the passivation film includes a contact hole corresponding to a region in which the first part and the driving thin-film transistor are over-

lapped with each other,  
wherein the anode electrically connects with the driving thin-film transistor through the contact hole.

Clause 3. The self light-emitting display device of clause 2, further comprising:

a pixel defining film configured to divide pixels, disposed above passivation film and covering edge of the anode,  
wherein the flattening part is disposed above the pixel defining film.

Clause 4. The self light-emitting display device of any preceding clause, wherein the color filter pattern includes a red filter unit, a green filter unit and a blue filter unit that are spaced apart from each other, the color conversion pattern includes a red conversion unit overlapped with the red filter unit, and a green conversion unit overlapped with the green filter unit.

Clause 5. The self light-emitting display device of any preceding clause, further comprising:

a cathode disposed above the light-emitting layer; and  
an encapsulation layer disposed above the cathode.

**[0088]** The embodiments have been described with reference to the attached drawings. However, the present disclosure is not limited to the embodiments. The disclosure may be modified in various different forms on the basis of a combination of descriptions of each embodiment. It will be apparent to those having ordinary skill in the art to which the present disclosure pertains that the disclosure may be implemented in other detailed forms without modifying the technical spirit and essential features of the disclosure. Therefore, it should be understood that the above-described embodiments are provided as examples but not construed as being limited, in all aspects.

## Claims

1. A light-emitting display device (1000), comprising:

a substrate including a circuit board and a color filter layer (R-CF, G-CF, B-CF, W-CF) disposed above the circuit board, wherein the circuit board includes a driving thin-film transistor (Td);  
a passivation film (PAC) disposed above the substrate;  
a color conversion layer (R-CCM, G-CCM) disposed above the passivation film (PAC) and overlapped with the color filter layer (R-CF, G-

CF, B-CF, W-CF); and  
a light-emitting layer (OG) disposed above the passivation film (PAC) and the color conversion layer (R-CCM, G-CCM), the light emitting layer (OG) including a flat part (OGF) and a convex part (OGP) which is disposed above the color conversion layer (R-CCM, G-CCM) and extends higher than the flat part (OGF).

2. The light-emitting display device of claim 1, wherein the circuit board comprises a thin film transistor "TFT" array, the TFT array including the driving thin-film transistor (Td).

3. The light-emitting display device of claim 1 or claim 2, further comprising:

an anode (A) including a first part (AF) disposed between the flat part (OGF) and the passivation film (PAC), and a second part (AP) disposed between the color conversion layer (R-CCM, G-CCM) and the convex part (OGP), wherein the second part (AP) extends higher than the first part (AF).

4. The light-emitting display device of claim 3, wherein the passivation film (PAC) includes a contact hole (372) corresponding to a region in which the first part (AF) and the driving thin-film transistor (Td) are overlapped with each other.

5. The light-emitting display device of claim 4, wherein the anode (A) electrically connects with the driving thin-film transistor (Td) through the contact hole (372).

6. The light-emitting display device of claim 3, 4 or 5, further comprising:  
a pixel defining film (380) configured to divide pixels, the pixel defining film disposed above passivation film (PAC) and covering edge of the anode (A).

7. The light-emitting display device of claim 5 or claim 6, wherein the flat part (OGF) is disposed above the pixel defining film (380).

8. The light-emitting display device of any preceding claim, wherein the color filter layer includes a red filter unit (R-CF), a green filter unit (G-CF) and a blue filter unit (B-CF) that are spaced apart from each other.

9. The light-emitting display device of claim 8, wherein the red filter unit, green filter unit, and blue filter unit are coplanar.

10. The light emitting display device of claim 8, wherein the color conversion layer (R-CCM, G-CCM) includes a red conversion unit (R-CCM) overlapped with the red filter unit (R-CF), and a green conversion

unit (G-CCM) overlapped with the green filter unit (G-CF).

11. The light-emitting display device of claim 10, wherein the red conversion unit and the green conversion unit are coplanar. 5
12. The light-emitting display device of any preceding claim, further comprising: 10
- a cathode (C) disposed above the light-emitting layer (OG); and
  - an encapsulation layer (EC) disposed above the cathode (C). 15
13. The light-emitting display device of claims 1 to 7, wherein the color filter layer comprises a plurality of color filter units, each color filter unit corresponding to a sub-pixel of the light-emitting display device. 20
14. The light-emitting display device of claim 13, wherein the sub-pixels are arranged in a matrix.
15. An organic light-emitting display device according to any preceding claim. 25

30

35

40

45

50

55

FIG. 1

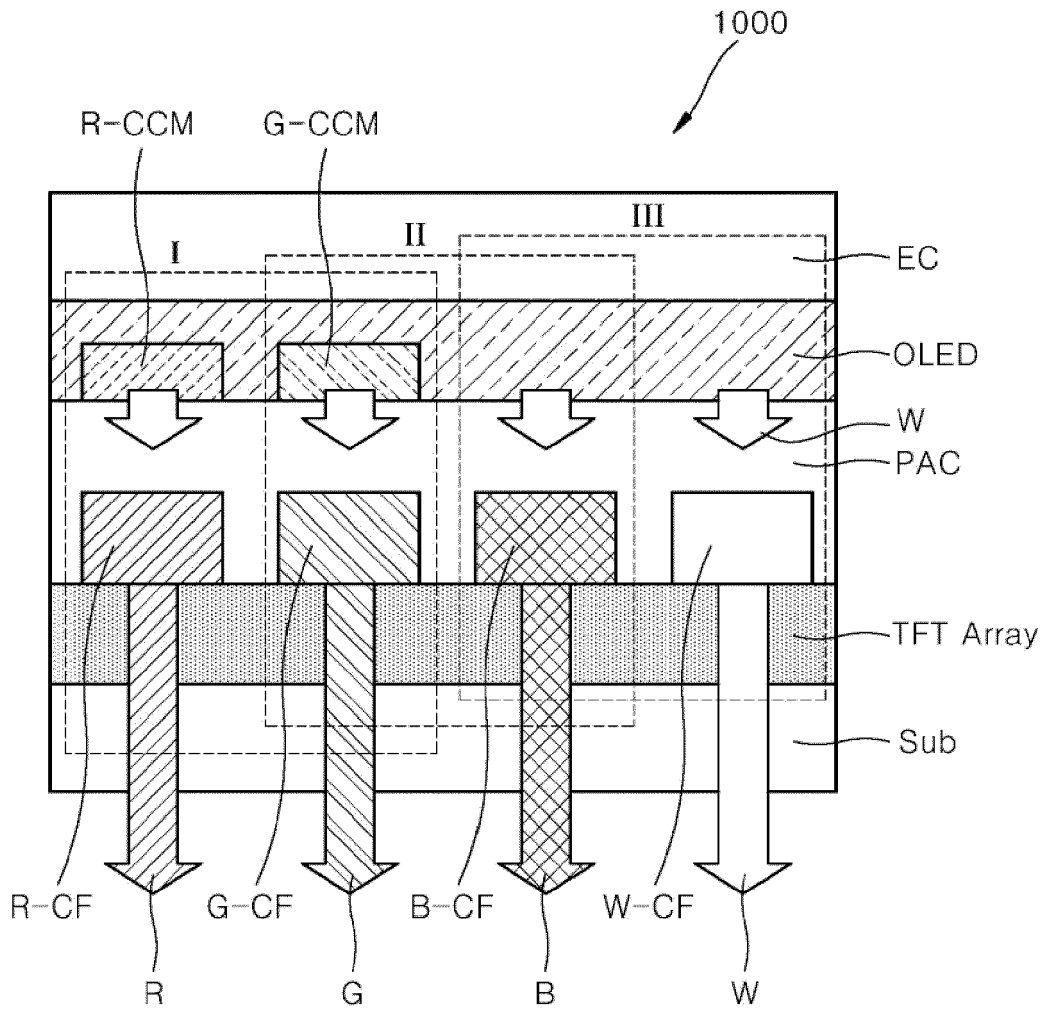
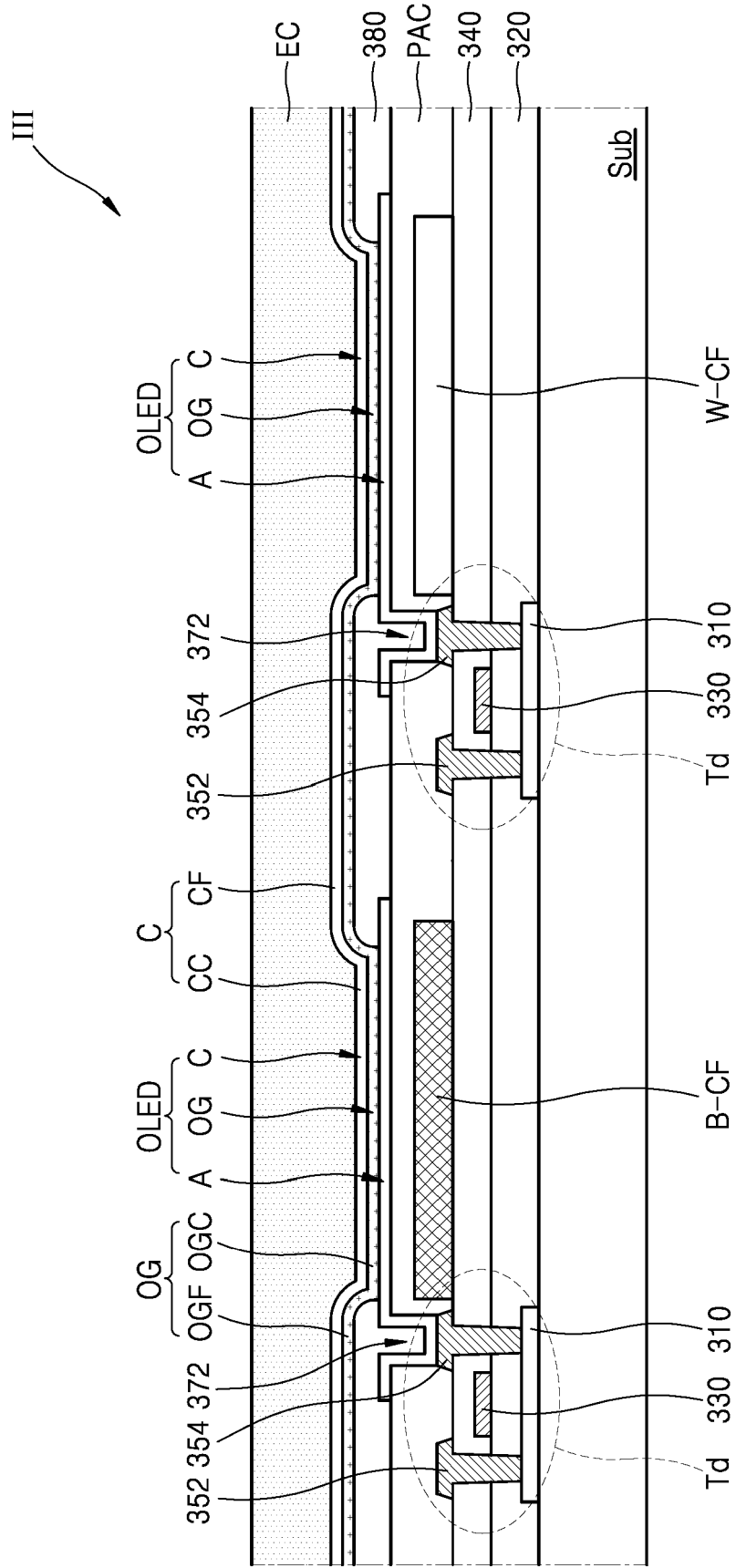





FIG. 4





EUROPEAN SEARCH REPORT

Application Number  
EP 19 20 0291

5

10

15

20

25

30

35

40

45

50

55

DOCUMENTS CONSIDERED TO BE RELEVANT			
Category	Citation of document with indication, where appropriate, of relevant passages	Relevant to claim	CLASSIFICATION OF THE APPLICATION (IPC)
X	US 2005/093435 A1 (SUH MIN-CHUL [KR] ET AL) 5 May 2005 (2005-05-05)	1-11,13,14	INV. H01L27/32
Y	* paragraph [0058] - paragraph [0062]; figure 8 *	12,15	H01L51/52
	* paragraph [0036] *		
	-----		
Y	EP 3 355 357 A1 (SAMSUNG DISPLAY CO LTD [KR]) 1 August 2018 (2018-08-01)	12,15	
	* paragraph [0118] - paragraph [0120]; figure 10 *		
	* paragraph [0085] *		
	-----		
The present search report has been drawn up for all claims			
Place of search <b>Munich</b>		Date of completion of the search <b>20 January 2020</b>	Examiner <b>Beierlein, Udo</b>
CATEGORY OF CITED DOCUMENTS X : particularly relevant if taken alone Y : particularly relevant if combined with another document of the same category A : technological background O : non-written disclosure P : intermediate document T : theory or principle underlying the invention E : earlier patent document, but published on, or after the filing date D : document cited in the application L : document cited for other reasons & : member of the same patent family, corresponding document			

EPO FORM 1503 03/02 (P04C01)

**ANNEX TO THE EUROPEAN SEARCH REPORT  
ON EUROPEAN PATENT APPLICATION NO.**

EP 19 20 0291

5 This annex lists the patent family members relating to the patent documents cited in the above-mentioned European search report.  
The members are as contained in the European Patent Office EDP file on  
The European Patent Office is in no way liable for these particulars which are merely given for the purpose of information.

20-01-2020

10

Patent document cited in search report	Publication date	Patent family member(s)	Publication date
US 2005093435 A1	05-05-2005	NONE	
-----			
EP 3355357 A1	01-08-2018	CN 108346681 A	31-07-2018
		EP 3355357 A1	01-08-2018
		KR 20180087908 A	03-08-2018
		US 2018211979 A1	26-07-2018
-----			

15

20

25

30

35

40

45

50

55

EPO FORM P0459

For more details about this annex : see Official Journal of the European Patent Office, No. 12/82

