



(12) **EUROPEAN PATENT APPLICATION**

(43) Date of publication:  
**12.02.2020 Bulletin 2020/07**

(51) Int Cl.:  
**H01L 51/54 (2006.01)**

(21) Application number: **19187595.4**

(22) Date of filing: **22.07.2019**

(84) Designated Contracting States:  
**AL AT BE BG CH CY CZ DE DK EE ES FI FR GB GR HR HU IE IS IT LI LT LU LV MC MK MT NL NO PL PT RO RS SE SI SK SM TR**  
 Designated Extension States:  
**BA ME**  
 Designated Validation States:  
**KH MA MD TN**

(72) Inventors:  
 • **Yoon, Kyung-Jin**  
**10845 Gyeonggi-do (KR)**  
 • **Noh, Hyo-Jin**  
**10845 Gyeonggi-do (KR)**  
 • **Baek, Jeong-Eun**  
**10845 Gyeonggi-do (KR)**

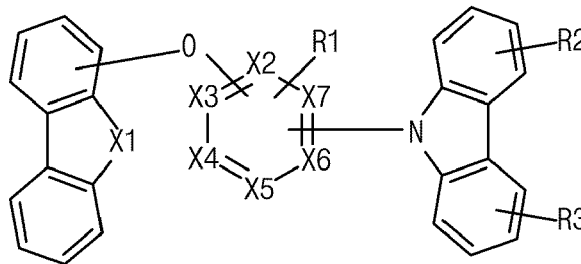
(30) Priority: **07.08.2018 KR 20180091757**

(74) Representative: **Ter Meer Steinmeister & Partner**  
**Patentanwälte mbB**  
**Nymphenburger Straße 4**  
**80335 München (DE)**

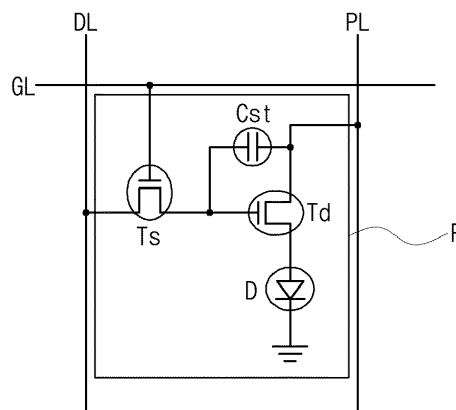
(71) Applicant: **LG Display Co., Ltd.**  
**SEOUL, 07336 (KR)**

(54) **ORGANIC COMPOUND, AND ORGANIC LIGHT EMITTING DIODE AND ORGANIC LIGHT EMITTING DISPLAY DEVICE INCLUDING THE SAME**

(57) The present invention provides an organic compound of following formula and an organic light emitting diode and an OLED device including the organic compound.



**FIG. 1**



**Description**

**CROSS-REFERENCE TO RELATED APPLICATIONS**

5 **[0001]** The present application claims the benefit of Korean Patent Application No. 10-2018-0091757 filed in the Republic of Korea on August 7, 2018.

BACKGROUND

10 FIELD OF TECHNOLOGY

**[0002]** The present disclosure relates to an organic compound, and more particularly, to an organic compound having high triplet energy and being used for an n-type host, and an organic light emitting diode and an organic light emitting display (OLED) device including the organic compound.

15

DISCUSSION OF THE RELATED ART

**[0003]** Recently, requirement for flat panel display devices having small occupied area is increased. Among the flat panel display devices, a technology of an OLED device, which includes an organic light emitting diode and may be called to as an organic electroluminescent device, is rapidly developed.

20

**[0004]** The organic light emitting diode emits light by injecting electrons from a cathode as an electron injection electrode and holes from an anode as a hole injection electrode into an organic emitting layer, combining the electrons with the holes, generating an exciton, and transforming the exciton from an excited state to a ground state. A flexible transparent substrate, for example, a plastic substrate, can be used as a base substrate where elements are formed. In addition, the organic light emitting diode can be operated at a voltage (e.g., 10V or below) lower than a voltage required to operate other display devices and has low power consumption. Moreover, the light from the organic light emitting diode has excellent color purity.

25

**[0005]** The organic emitting layer may have a single-layered structure of an emitting material layer (EML). Alternatively, to improve the emission efficiency, the organic emitting layer may have a multi-layered structure. For example, the organic emitting layer may include a hole injection layer (HIL), a hole transporting layer (HTL), the EML, an electron transporting layer (ETL) and an electron injection layer (EIL).

30

**[0006]** The EML includes a dopant as an emitter. However, since the emission efficiency of the dopant is rapidly decreased by a concentration quenching problem, there is a limitation in the OLED device including the EML with only dopant. Accordingly, the EML further includes a host.

35

**[0007]** For example, an organic compound such as CBP may be used as the host in the EML. However, in the related art organic light emitting diode, there are limitations in the lifespan and the emitting efficiency.

**[0008]** Namely, there are limitations in the lifespan and the emitting efficiency of the organic light emitting diode and the OLED device.

40 SUMMARY

**[0009]** The present invention is directed to an organic compound, an organic light emitting diode and an OLED device that substantially obviate one or more of the problems associated with the limitations and disadvantages of the related conventional art.

**[0010]** Additional features and advantages of the invention are set forth in the description which follows, and will be apparent from the description, or evident by practice of the invention. The objectives and other advantages of the invention are realized and attained by the features described herein as well as in the appended drawings.

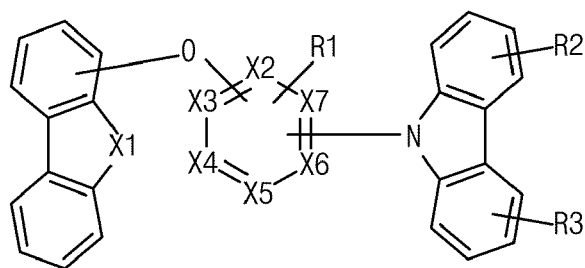
45

**[0011]** To achieve these and other advantages in accordance with the purpose of the embodiments of the invention, as described herein, an aspect of the invention is an organic compound represented by Formula 1:

50

55

[Formula 1]



wherein X1 is selected from the group consisting of oxygen and sulfur, and each of X2 to X7 is independently selected from the group consisting of carbon and nitrogen, and wherein R1 is selected from the group consisting of hydrogen and cyano group, and each of R2 and R3 is independently selected from the group consisting of hydrogen and heteroaryl group.

**[0012]** Another aspect of the invention is an organic light emitting diode including a first electrode; a second electrode facing the first electrode; and a first emitting material layer between the first and second electrodes and including an organic compound.

**[0013]** Another aspect of the invention is an organic light emitting display device including a substrate; an organic light emitting diode disposed on the substrate; a thin film transistor positioned between the substrate and the organic light emitting diode and connected to the organic light emitting diode.

**[0014]** It is to be understood that both the foregoing general description and the following detailed description are exemplary and explanatory and are intended to further explain the invention as claimed.

#### BRIEF DESCRIPTION OF THE DRAWINGS

**[0015]** The accompanying drawings, which are included to provide a further understanding of the invention and are incorporated in and constitute a part of this specification, illustrate embodiments of the invention and together with the description serve to explain the principles of the invention.

FIG. 1 is a schematic circuit diagram of an OLED device of the present disclosure.

FIG. 2 is a schematic cross-sectional view of an OLED device of the present disclosure.

FIG. 3 is a schematic cross-sectional view of an organic light emitting diode of the present disclosure.

FIGs. 4A and 4B are schematic view illustrating emission in an organic light emitting diode using a p-type host and an organic light emitting diode of the present disclosure, respectively.

FIG. 5 is a view illustrating an emission mechanism of a delayed fluorescent compound.

FIG. 6 is a view illustrating an emission mechanism of an organic light emitting diode of the present disclosure.

FIG. 7 is a schematic cross-sectional view of an organic light emitting diode of the present disclosure.

FIG. 8 is a schematic cross-sectional view of an organic light emitting diode of the present disclosure.

#### DETAILED DESCRIPTION

**[0016]** Reference will now be made in detail to some of the examples and preferred embodiments, which are illustrated in the accompanying drawings.

**[0017]** FIG. 1 is a schematic circuit diagram of an OLED device of the present disclosure.

**[0018]** As shown in FIG. 1, an OLED device includes a gate line GL, a data line DL, a power line PL, a switching thin film transistor TFT Ts, a driving TFT Td, a storage capacitor Cst, and an organic light emitting diode D. The gate line GL and the data line DL cross each other to define a pixel region SP.

**[0019]** The switching TFT Ts is connected to the gate line GL and the data line DL, and the driving TFT Td and the storage capacitor Cst are connected to the switching TFT Ts and the power line PL. The organic light emitting diode D is connected to the driving TFT Td.

**[0020]** In the OLED device, when the switching TFT Ts is turned on by a gate signal applied through the gate line GL, a data signal from the data line DL is applied to the gate electrode of the driving TFT Td and an electrode of the storage capacitor Cst.

[0021] When the driving TFT Td is turned on by the data signal, an electric current is supplied to the organic light emitting diode D from the power line PL. As a result, the organic light emitting diode D emits light. In this case, when the driving TFT Td is turned on, a level of an electric current applied from the power line PL to the organic light emitting diode D is determined such that the organic light emitting diode D can produce a gray scale.

5 [0022] The storage capacitor Cst serves to maintain the voltage of the gate electrode of the driving TFT Td when the switching TFT Ts is turned off. Accordingly, even if the switching TFT Ts is turned off, a level of an electric current applied from the power line PL to the organic light emitting diode D is maintained to next frame.

[0023] As a result, the OLED device displays a desired image.

[0024] FIG. 2 is a schematic cross-sectional view of an OLED device of the present disclosure.

10 [0025] As shown in FIG. 2, the OLED device 100 includes a substrate 110, a TFT Tr and an organic light emitting diode D connected to the TFT Tr.

[0026] The substrate 110 may be a glass substrate or a plastic substrate. For example, the substrate 110 may be a polyimide substrate.

15 [0027] A buffer layer 120 is formed on the substrate, and the TFT Tr is formed on the buffer layer 120. The buffer layer 120 may be omitted.

[0028] A semiconductor layer 122 is formed on the buffer layer 120. The semiconductor layer 122 may include an oxide semiconductor material or polycrystalline silicon.

20 [0029] When the semiconductor layer 122 includes the oxide semiconductor material, a light-shielding pattern (not shown) may be formed under the semiconductor layer 122. The light to the semiconductor layer 122 is shielded or blocked by the light-shielding pattern such that thermal degradation of the semiconductor layer 122 can be prevented. On the other hand, when the semiconductor layer 122 includes polycrystalline silicon, impurities may be doped into both sides of the semiconductor layer 122.

[0030] A gate insulating layer 124 is formed on the semiconductor layer 122. The gate insulating layer 124 may be formed of an inorganic insulating material such as silicon oxide or silicon nitride.

25 [0031] A gate electrode 130, which is formed of a conductive material, e.g., metal, is formed on the gate insulating layer 124 to correspond to a center of the semiconductor layer 122.

[0032] In FIG. 2, the gate insulating layer 124 is formed on an entire surface of the substrate 110. Alternatively, the gate insulating layer 124 may be patterned to have the same shape as the gate electrode 130.

30 [0033] An interlayer insulating layer 132, which is formed of an insulating material, is formed on the gate electrode 130. The interlayer insulating layer 132 may be formed of an inorganic insulating material, e.g., silicon oxide or silicon nitride, or an organic insulating material, e.g., benzocyclobutene or photo-acryl.

[0034] The interlayer insulating layer 132 includes first and second contact holes 134 and 136 exposing both sides of the semiconductor layer 122. The first and second contact holes 134 and 136 are positioned at both sides of the gate electrode 130 to be spaced apart from the gate electrode 130.

35 [0035] The first and second contact holes 134 and 136 are formed through the gate insulating layer 124. Alternatively, when the gate insulating layer 124 is patterned to have the same shape as the gate electrode 130, the first and second contact holes 134 and 136 is formed only through the interlayer insulating layer 132.

[0036] A source electrode 140 and a drain electrode 142, which are formed of a conductive material, e.g., metal, are formed on the interlayer insulating layer 132.

40 [0037] The source electrode 140 and the drain electrode 142 are spaced apart from each other with respect to the gate electrode 130 and respectively contact both sides of the semiconductor layer 122 through the first and second contact holes 134 and 136.

[0038] The semiconductor layer 122, the gate electrode 130, the source electrode 140 and the drain electrode 142 constitute the TFT Tr. The TFT Tr serves as a driving element.

45 [0039] In the TFT Tr, the gate electrode 130, the source electrode 140, and the drain electrode 142 are positioned over the semiconductor layer 122. Namely, the TFT Tr has a coplanar structure.

[0040] Alternatively, in the TFT Tr, the gate electrode may be positioned under the semiconductor layer, and the source and drain electrodes may be positioned over the semiconductor layer such that the TFT Tr may have an inverted staggered structure. In this instance, the semiconductor layer may include amorphous silicon.

50 [0041] Although not shown, the gate line and the data line cross each other to define the pixel region, and the switching TFT is formed to be connected to the gate and data lines. The switching TFT is connected to the TFT Tr as the driving element.

[0042] In addition, the power line, which may be formed to be parallel to and spaced apart from one of the gate and data lines, and the storage capacitor for maintaining the voltage of the gate electrode of the TFT Tr in one frame may be further formed.

55 [0043] A passivation layer 150, which includes a drain contact hole 152 exposing the drain electrode 142 of the TFT Tr, is formed to cover the TFT Tr.

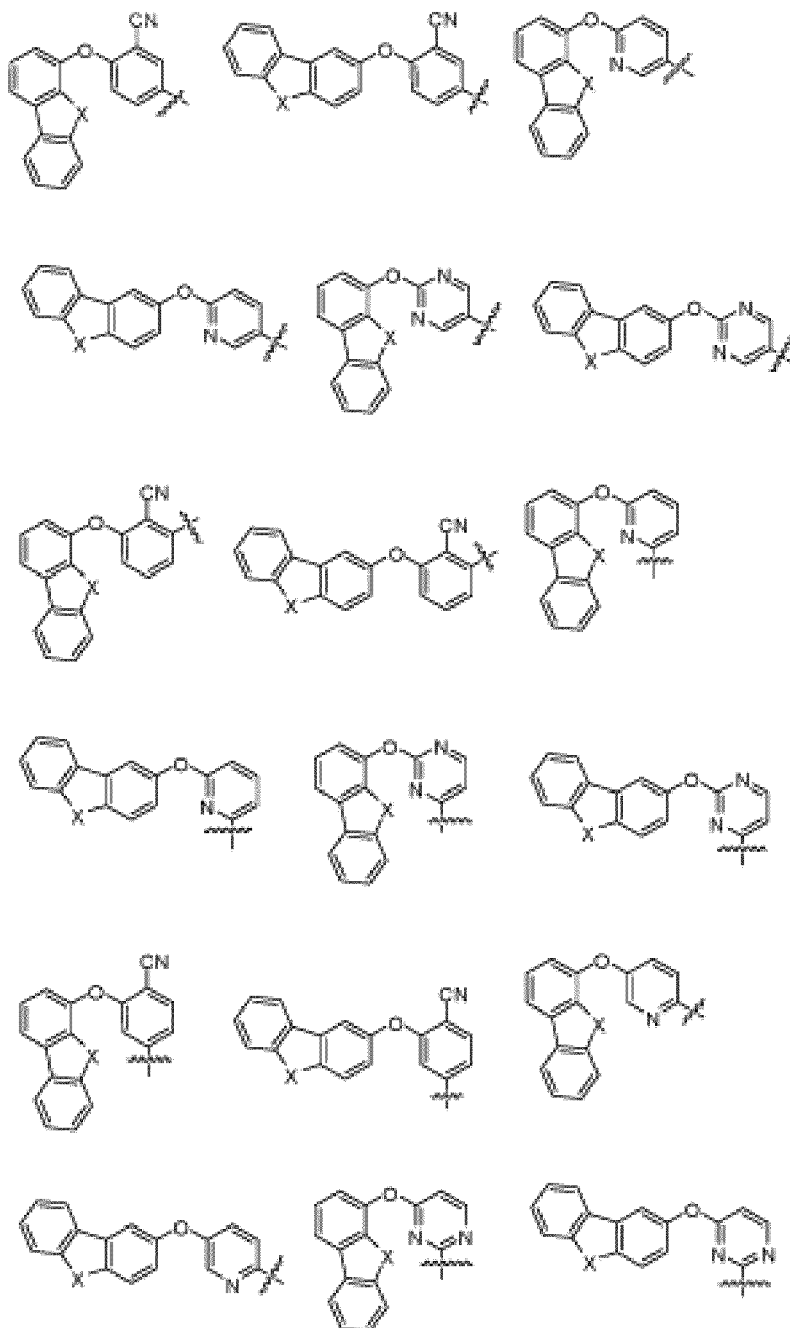
[0044] A first electrode 160, which is connected to the drain electrode 142 of the TFT Tr through the drain contact

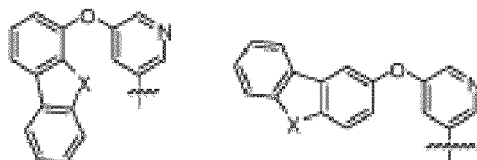


or non-substituted carbazolyl, and an electron acceptor moiety connected to the electron donor moiety. The electron acceptor moiety includes first and second electron acceptor moieties connected to each other by oxygen linker. In other words, the organic compound includes two electron acceptor moieties to have an n-type property, and two electron acceptor moieties are connected by an ether bond such that the conjugation length is decreased and the triplet energy of the organic compound is increased.

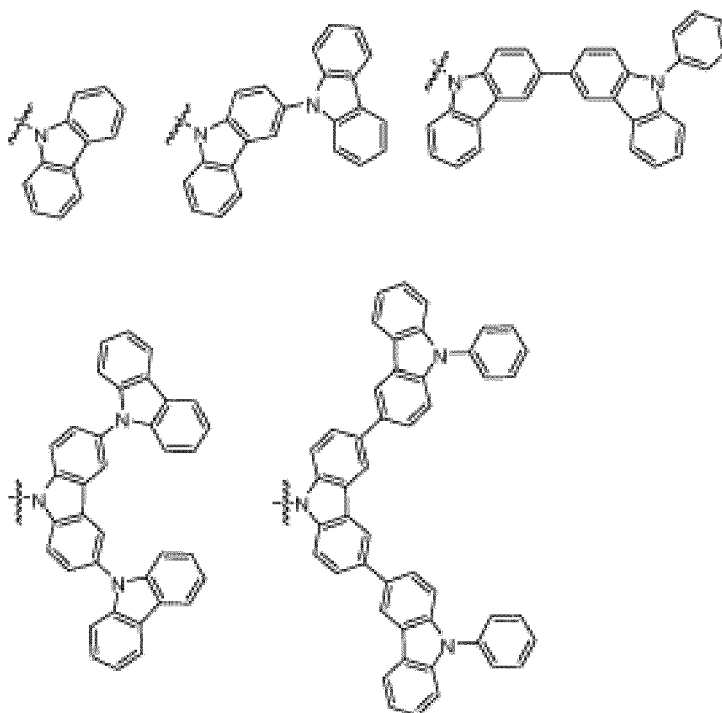
**[0061]** For example, the electron acceptor moiety of the organic compound may be selected from the groups in Formula 2, and the electron donor moiety of the organic compound may be selected from the group in Formula 3.

[Formula 2]





[Formula 3]



**[0062]** As mentioned above, the organic compound of the present disclosure may be used as a host and has high triplet energy. Accordingly, the organic light emitting diode and the OLED device including the organic compound as the host in the EML have advantages in the emitting efficiency and the lifespan.

**[0063]** The dopant included in the EML 240 with the organic compound as the host may be at least one of a fluorescent dopant, a phosphorescent dopant and a delayed fluorescent dopant. For example, the dopant may have a weight % of about 1 to 50 with respect to the host.

**[0064]** In the EML 240, the quenching problem of the exciton by an interaction between the triplet exciton of the dopant and the hole-polaron may be generated. To prevent the quenching problem, an n-type host is required. However, when the n-type property of the host is increased, the triplet energy of the host is decreased such that the triplet exciton of the dopant is transferred into the triplet energy level of the host. As a result, the emitting efficiency is decreased.

**[0065]** However, since the organic compound of the present disclosure includes an ether bond, the organic compound has high triplet energy with the n-type property. Accordingly, in the organic light emitting diode D of the present disclosure, the quenching problem of the exciton by an interaction between the triplet exciton of the dopant and the hole-polaron and the energy transferring problem from the dopant to the host by low triplet energy of the host are prevented or minimized.

**[0066]** In addition, when the n-type organic compound of the present disclosure is used as the host, the emitting zone, i.e., a recombination zone, resulting from the combination between the electron and the hole is generated at a region near an interface between the EML and the EBL such that the lifespan of the organic light emitting diode is improved.

**[0067]** Namely, referring to FIG. 4A, which is a view illustrating emission in an organic light emitting diode using a p-type host, the mobility of the hole becomes relatively fast due to the p-type host in the EML such that the emitting zone (recombination zone) is generated to be near an interface between the EML and the HBL.

**[0068]** On the other hand, referring to FIG. 4B, which is a view illustrating emission in an organic light emitting diode of the present disclosure, the mobility of the electron becomes relatively fast due to the n-type host, i.e., the organic compound of the present disclosure, in the EML such that the emitting zone (recombination zone) is generated to be near an interface between the EML and the EBL.

**[0069]** A position of the emitting zone is shifted by the property difference between the p-type host and the n-type host such that the lifespan of the organic light emitting diode (D) is also changed.

**[0070]** In all cases of the light emitting diodes using the p-type host and the n-type host, the emitting zone is generated to be shifted one side of the EML. However, when the emitting zone is generated to be closer to the first electrode, for example, in a region near an interface between one of the EBL and the HTL and the EML, the emitting efficiency and the lifespan of the organic light emitting diode are improved.

**[0071]** Referring to FIG. 5, which is a view illustrating an emission mechanism of a delayed fluorescent compound, in the delayed fluorescent compound, the singlet exciton and the triplet exciton are engaged in the emission such that the quantum efficiency is improved.

**[0072]** Namely, in the delayed fluorescent compound, when the triplet exciton is activated by a field or heat, and the triplet exciton and the singlet exciton are transferred into an intermediated state and transited into a ground state to emit light. In other words, the singlet state and the triplet state are engaged in the emission such that the emitting efficiency is improved.

**[0073]** When the EML 240 includes the delayed fluorescent dopant (delayed fluorescent compound) with the organic compound of the present disclosure as the host, a difference between the HOMO of the host " $\text{HOMO}_{\text{Host}}$ " and the HOMO of the delayed fluorescent dopant " $\text{HOMO}_{\text{Dopant}}$ " or a difference between the LUMO of the host " $\text{LUMO}_{\text{Host}}$ " and the LUMO of the delayed fluorescent dopant " $\text{LUMO}_{\text{Dopant}}$ " is less than about 0.5 eV. In this instance, the charge transfer efficiency from the host to the dopant may be improved.

**[0074]** The triplet energy of the delayed fluorescent dopant is smaller than the triplet energy of the host, and a difference between the singlet energy of the delayed fluorescent dopant and the triplet energy of the delayed fluorescent dopant is less than 0.3eV. ( $\Delta E_{\text{ST}} \leq 0.3\text{eV}$ .) As the difference " $\Delta E_{\text{ST}}$ " is smaller, the emitting efficiency is higher. In addition, even if the difference " $\Delta E_{\text{ST}}$ " between the singlet energy of the delayed fluorescent dopant and the triplet energy of the delayed fluorescent dopant is about 0.3eV, which is relatively large, the excitons in the singlet state and the excitons in the triplet state can be transited into the intermediate state.

**[0075]** The EML 240 may include the organic compound of the present disclosure as the host with the delayed fluorescent dopant as a first dopant and the fluorescent dopant as a second dopant. The summation of the first dopant and the second dopant may be about 1 to 50 wt% with respect to the host.

**[0076]** The singlet energy of the first dopant may be smaller than that of the host and larger than that of the second dopant. The triplet energy of the first dopant may be smaller than that of the host and larger than that of the second dopant.

**[0077]** Referring to FIG. 6, which is a view illustrating an emission mechanism of an organic light emitting diode of the present disclosure, the triplet energy ( $E_{\text{T}_1}(\text{TD})$ ) of the delayed fluorescent dopant, i.e., the first dopant, is converted into the singlet energy ( $E_{\text{S}_1}(\text{TD})$ ) by an effect of a reverse intersystem crossing (RISC), and the singlet energy ( $E_{\text{S}_1}(\text{TD})$ ) of the delayed fluorescent dopant is transferred into the singlet energy ( $E_{\text{S}_1}(\text{FD})$ ) of the fluorescent dopant, i.e., the second dopant by an effect of Foster resonance energy transfer. As a result, the light is emitted from the fluorescent dopant.

**[0078]** In the organic light emitting diode D, since the EML 240 includes the host, the first dopant and the second dopant, the emitting efficiency and the color purity are improved. Namely, since the energy is transferred from the host into the first dopant and both the singlet energy and the triplet energy of the first dopant are transferred into the second dopant, the emission is generated from the second dopant such that the quantum efficiency of the organic light emitting diode D is increased and the full width at half maximum (FWHM) of the light from the organic light emitting diode D is narrowed.

**[0079]** The delayed fluorescent dopant as the first dopant has high quantum efficiency. However, since the light emitted from the delayed fluorescent dopant has wide FWHM, the light from the delayed fluorescent dopant has bad color purity. On the other hand, the fluorescent dopant as the second dopant has narrow FWHM and high color purity. However, since the triplet energy of the fluorescent dopant is not engaged in the emission, the fluorescent dopant has low quantum efficiency.

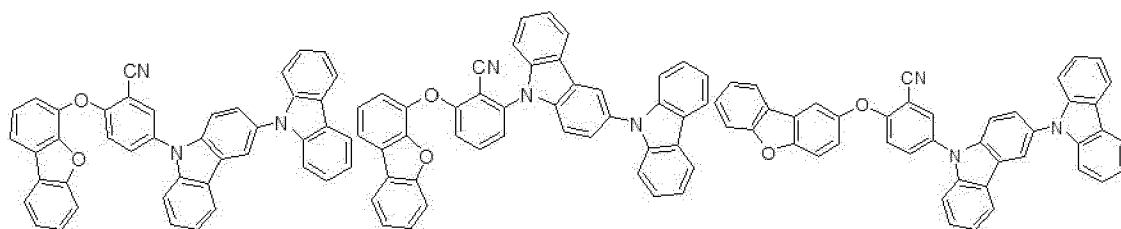
**[0080]** Since the EML 240 of the organic light emitting diode D in the present disclosure includes the host, the first dopant and the second dopant, the organic light emitting diode D has advantages in both the emitting efficiency and the color purity.

**[0081]** In addition, since the organic compound of the present disclosure, which has high triplet energy and the n-type property, is used as the host, the emitting efficiency is further improved.

**[0082]** For example, the organic compound of the present disclosure in Formula 1 may be one of compounds in Formula 4.

[Formula 4]

5

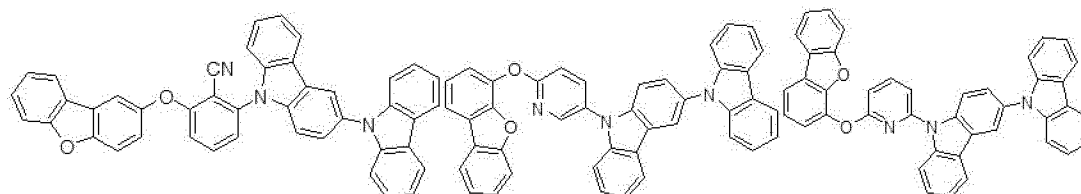


compound 1

compound 2

compound 3

10



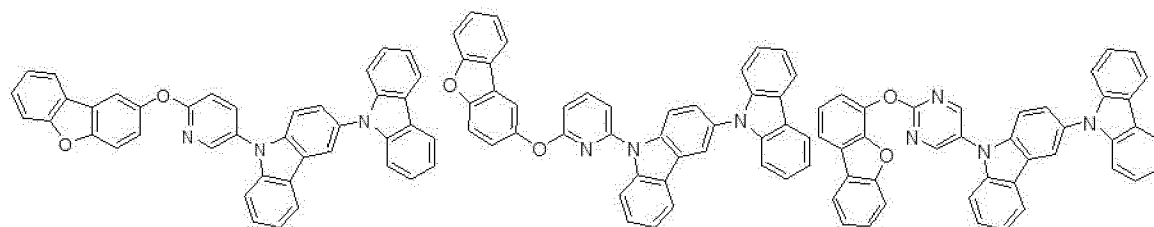
compound 4

compound 5

compound 6

15

20



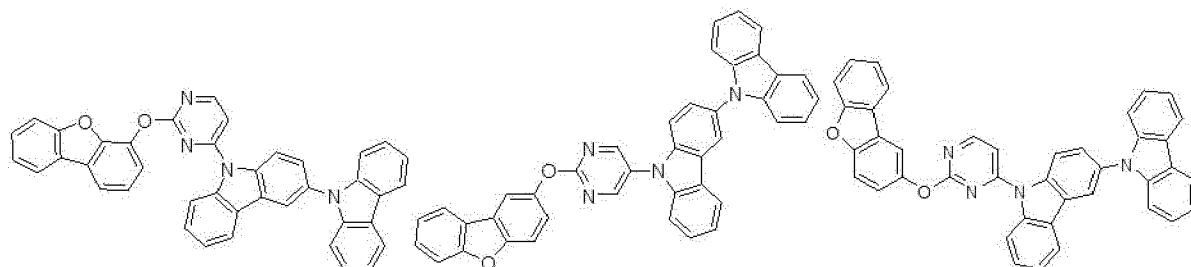
compound 7

compound 8

compound 9

25

30



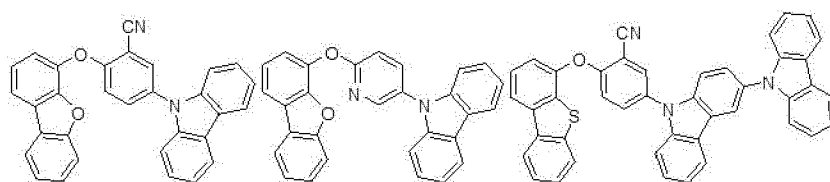
compound 10

compound 11

compound 12

35

40



compound 13

compound 14

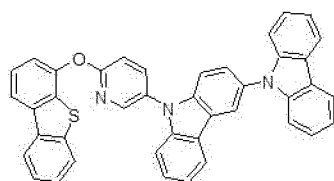
compound 15

45

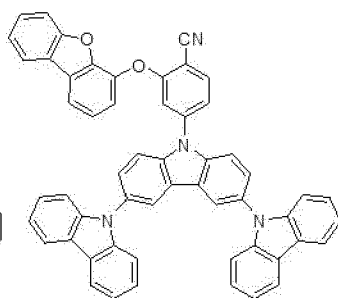
50

55

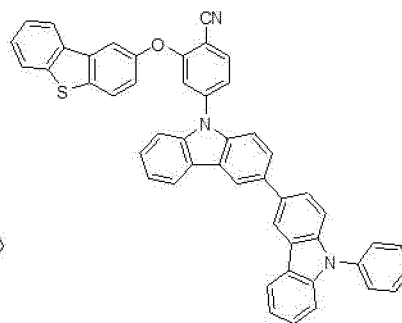
5



compound 16

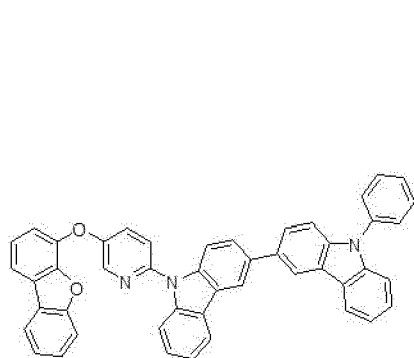


compound 17

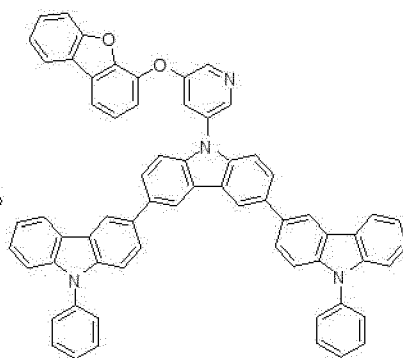


compound 18

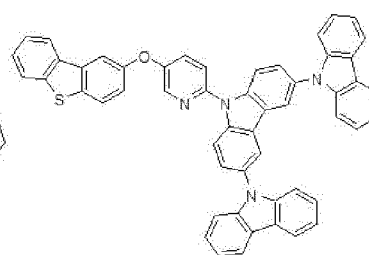
15



compound 19



compound 20



compound 21

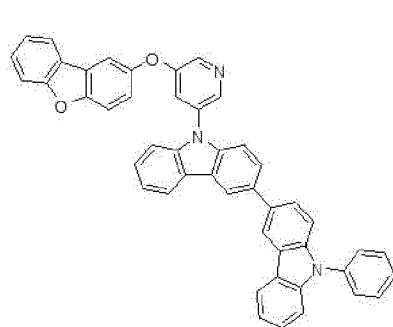
20

25

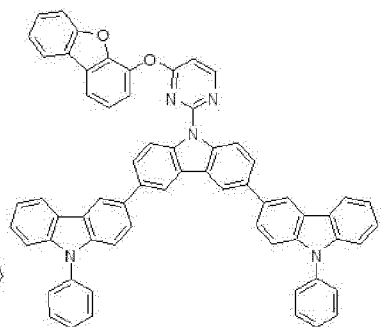
30

35

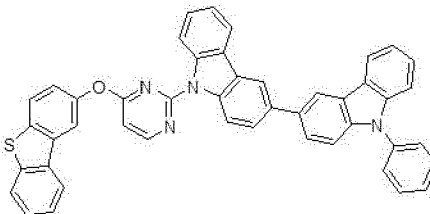
40



compound 22



compound 23



compound 24

[Synthesis of organic compounds]

45

1. Synthesis of compound 1

(1) compound C

50

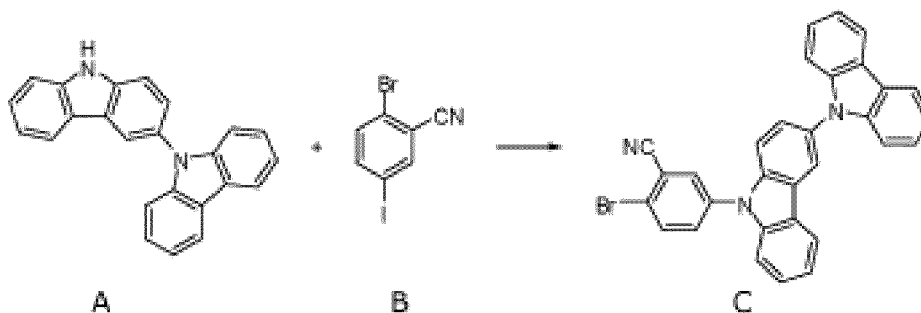
[0083]

[Reaction Formula 1-1]

55

5

10



15

**[0084]** Under nitrogen condition, the compound B was dissolved in dioxane, and the compound A (0.9 equivalent) was added. Potassium phosphate (4.0 equivalent) was added, and CuI (0.2 equivalent) and 1,2-diaminocyclohexane (0.2 equivalent) were added. The mixture was refluxed and stirred for 12 hrs, and then the reaction was finished. The resultant was extracted using an organic solvent, and the organic solvent was removed. The resultant was columned and reprecipitated such that the compound C was obtained.

20

(2) compound 1

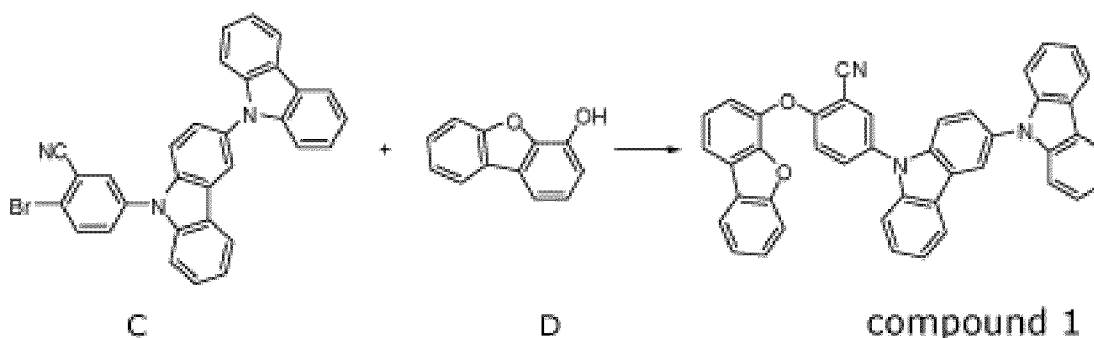
**[0085]**

25

[Reaction Formula 1-2]

30

35



40

**[0086]** Under nitrogen condition, the compound C was dissolved in dimethylsulfoxide (DMSO), and the compound D (1.4 equivalent) was added. Potassium phosphate (2.0 equivalent) was added, and CuI (0.1 equivalent) and picolinic acid (0.2 equivalent) were added. The mixture was refluxed under the temperature of 80 °C and stirred for 20 hrs, and then the reaction was finished. The resultant was extracted using an organic solvent, and the organic solvent was removed. The resultant was columned and reprecipitated such that the compound 1 was obtained.

45

2. Synthesis of compound 5

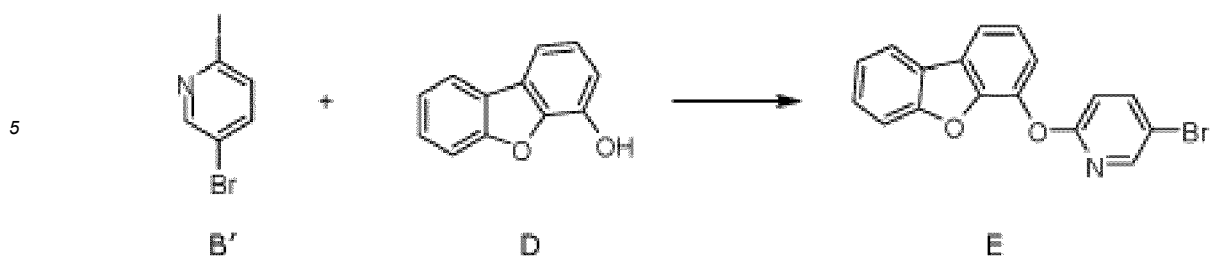
(1) compound E

**[0087]**

50

[Reaction Formula 2-1]

55



[0088] Under nitrogen condition, the compound B' was dissolved in DMSO, and the compound D (1.1 equivalent) was added. Potassium phosphate (3.0 equivalent) was added, and CuI (0.5 equivalent) and picolinic acid (0.5 equivalent) were added. The mixture was refluxed under the temperature of 80 °C and stirred for 4 hrs, and then the reaction was finished. The resultant was extracted using an organic solvent, and the organic solvent was removed. The resultant was

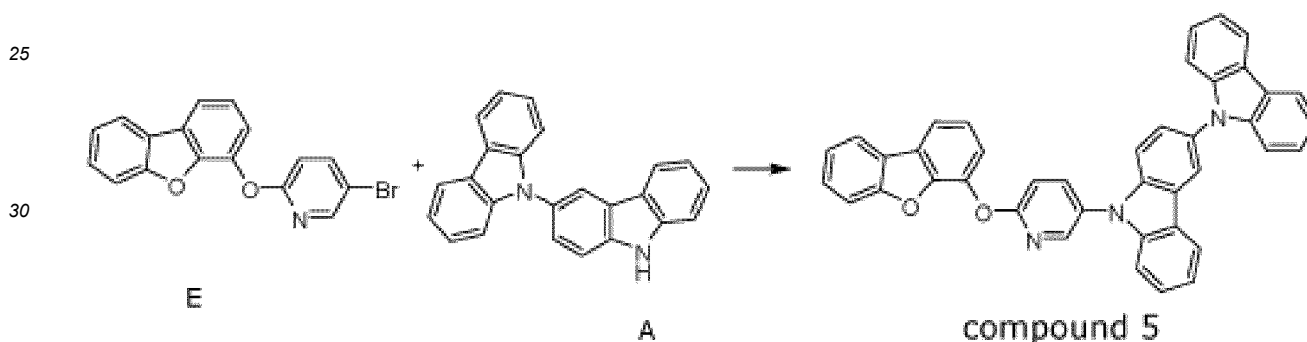
15

columned and reprecipitated such that the compound E was obtained.

(2) compound 5

[0089]

[Reaction Formula 2-2]



[0090] Under nitrogen condition, the compound E was dissolved in dioxane, and the compound A (1.2 equivalent) was added. Potassium phosphate (4.0 equivalent) was added, and CuI (0.2 equivalent) and 1,2-diaminocyclohexane (0.2 equivalent) were added. The mixture was refluxed and stirred for 20 hrs, and then the reaction was finished. The resultant was extracted using an organic solvent, and the organic solvent was removed. The resultant was columned and reprecipitated such that the compound 5 was obtained.

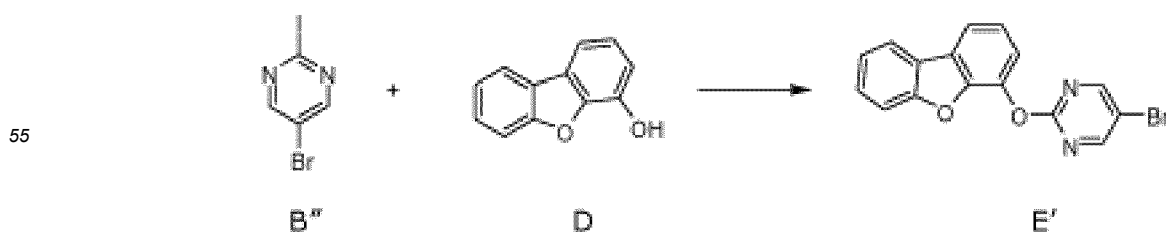
40

3. Synthesis of compound 9

(1) compound E'

[0091]

[Reaction Formula 3-1]

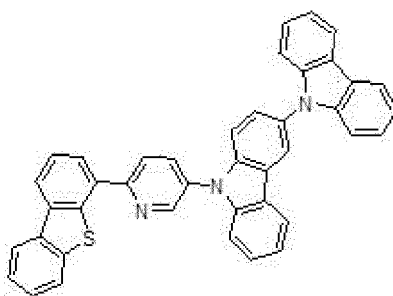




## [Reference Formula 1]

5

10



## [Reference Formula 2]

15

20

25

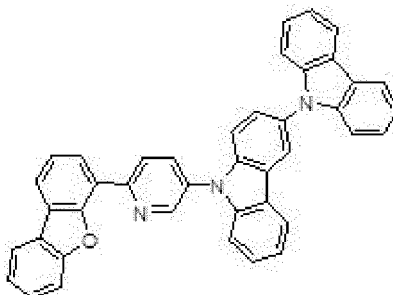


Table 1

30

	HOMO	LUMO	T1
Reference Formula 1	-5.74	-2.48	2.71
Reference Formula 2	-5.74	-2.39	2.79
compound 1	-5.75	-2.30	3.17
compound 3	-5.78	-2.51	3.06
compound 5	-5.73	-2.37	3.17
compound 9	-5.81	-2.56	3.01
compound 15	-5.67	-2.25	2.92

35

40

**[0098]** As shown in Table 1, in comparison to the compounds in Reference Formulas 1 and 2, where no ether bond is included, the organic compound of the present disclosure has higher triplet energy. Accordingly, the organic compound used as the host in the EML provides high energy efficiency. In addition, since the organic compound of the present disclosure has the n-type property, the emitting zone is shifted such that the emitting efficiency and the lifespan of the organic light emitting diode and the OLED device are improved.

45

[Organic light emitting diode]

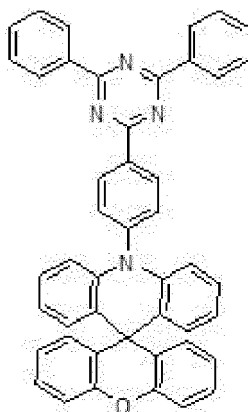
50

**[0099]** In the vacuum chamber of about  $10^{-7}$  Torr, layers are sequentially deposited on an ITO substrate.

**[0100]** (a) HIL (50 Å, HATCN), (b) HTL (500 Å, NPB), (c) EBL (100 Å, mCP), (d) EML (300 Å, HOST: Dopant (30wt%, Formula 7)), (e) ETL (300 Å, TPBI), (f) EIL (10 Å, LiF), and (g) Cathode (1000 Å, A1)

55

[Formula 7]



(1) Comparative Example 1 (Ref1)

**[0101]** The compound of Reference Formula 1 is used as the host.

(2) Comparative Example 2 (Ref2)

**[0102]** The compound of Reference Formula 2 is used as the host.

(3) Example 1 (Ex1)

**[0103]** The compound 1 of Formula 4 is used as the host.

(4) Example 2 (Ex2)

**[0104]** The compound 5 of Formula 4 is used as the host.

(5) Example 3 (Ex3)

**[0105]** The compound 9 of Formula 4 is used as the host.

**[0106]** The properties of the organic light emitting diodes of Ref1, Ref2 and Ex1 to Ex3 are measured. The driving voltage, the external quantum efficiency (EQE), the power efficiency (1m/W), the CIE color coordinate of the organic light emitting diodes are listed in Table 2.

Table 2

	V	EQE [%]	lm/W	CIEy
Ref 1	3.7	8.48	13.2	0.334
Ref 2	3.6	9.80	15.8	0.313
EX 1	3.6	15.4	26.2	0.319
Ex 2	3.4	13.6	23.2	0.307
Ex 3	3.5	12.0	18.5	0.332

**[0107]** As shown in Table 2, in comparison to the organic light emitting diodes of Ref1 and Ref2, the emitting efficiency, e.g., the EQE and the power efficiency, of the organic light emitting diodes of Ex1 to Ex3 using the organic compounds of the present disclosure as the host is remarkably increased.

**[0108]** FIG. 7 is a schematic cross-sectional view of an organic light emitting diode of the present disclosure.

**[0109]** As shown in FIG. 7, an organic light emitting diode D includes the first and second substrates 160 and 164, which face each other, and the organic emitting layer 162 therebetween. The organic emitting layer 162 includes an

EML 340, which includes first and second layers 342 and 344 and is positioned between the first and second electrodes 160 and 164, a HTL 320 between the first electrode 160 and the EML 340 and an ETL 360 between the second electrode 164 and the EML 340.

5 [0110] In addition, the organic emitting layer 162 may further include a HIL 310 between the first electrode 160 and the HTL 320 and an EIL 370 between the second electrode 164 and the ETL 360.

[0111] Moreover, the organic emitting layer 162 may further include an EBL 330 between the HTL 320 and the EML 340 and a HBL 350 between the EML 340 and the ETL 360.

10 [0112] For example, in the EML 340, the first layer 342 (e.g., a first emitting material layer) may include the organic compound of the present disclosure as a first host and a delayed fluorescent dopant as a first dopant, and the second layer 344 (e.g., a second emitting material layer) may include a second host and a fluorescent dopant as a second dopant. Alternatively, the second layer 344 may include the organic compound of the present disclosure as a first host and a delayed fluorescent dopant as a first dopant, and the first layer 342 may include a second host and a fluorescent dopant as a second host. The second host may be the organic compound of the present disclosure. The delayed fluorescent dopant has a singlet energy being larger than the fluorescent dopant.

15 [0113] The organic light emitting diode, where the first layer 342 includes the delayed fluorescent dopant and the second layer 344 includes the fluorescent dopant, will be explained.

[0114] In the organic light emitting diode D, the singlet energy and the triplet energy of the delayed fluorescent dopant are transferred into the fluorescent dopant such that the emission is generated from the fluorescent dopant. Accordingly, the quantum efficiency of the organic light emitting diode D is increased, and the FWHM of the organic light emitting diode D is narrowed.

20 [0115] The delayed fluorescent dopant as the first dopant has high quantum efficiency. However, since the light emitted from the delayed fluorescent dopant has wide FWHM, the light from the delayed fluorescent dopant has bad color purity. On the other hand, the fluorescent dopant as the second dopant has narrow FWHM and high color purity. However, since the triplet energy of the fluorescent dopant is not engaged in the emission, the fluorescent dopant has low quantum efficiency.

25 [0116] Since the EML 340 of the organic light emitting diode D in the present disclosure includes the first layer 342, which includes the delayed fluorescent dopant, and the second layer 344, which includes the fluorescent dopant, the organic light emitting diode D has advantages in both the emitting efficiency and the color purity.

30 [0117] The triplet energy of the delayed fluorescent dopant is converted into the singlet energy of the delayed fluorescent dopant by the RISC effect, and the singlet energy of the delayed fluorescent dopant is transferred into the singlet energy of the fluorescent dopant. Namely, the difference between the triplet energy of the delayed fluorescent dopant and the singlet energy of the delayed fluorescent dopant is less than 0.3eV such that the triplet energy of the delayed fluorescent dopant is converted into the singlet energy of the delayed fluorescent dopant by the RISC effect.

35 [0118] As a result, the delayed fluorescent dopant has an energy transfer function, and the first layer 342 including the delayed fluorescent dopant is not engaged in the emission. The emission is generated in the second layer 344 including the fluorescent dopant.

40 [0119] The triplet energy of the delayed fluorescent dopant is converted into the singlet energy of the delayed fluorescent dopant by the RISC effect. In addition, since the singlet energy of the delayed fluorescent dopant is higher than that of the fluorescent dopant, the singlet energy of the delayed fluorescent dopant is transferred into the singlet energy of the fluorescent dopant. As a result, the fluorescent dopant emits the light using the singlet energy and the triplet energy such that the quantum efficiency (emitting efficiency) of the organic light emitting diode D is improved.

[0120] In other words, the organic light emitting diode D and the OLED device 100 (of FIG. 2) including the organic light emitting diode D has advantages in both the emitting efficiency and the color purity.

45 [0121] In each of the first and second layers 342 and 344, the first and second hosts may have a percentage by weight being larger than the delayed fluorescent dopant and the fluorescent dopant, respectively. In addition, the percentage by weight of the delayed fluorescent dopant in the first layer 342 may be greater than that of the fluorescent dopant in the second layer 344. As a result, the energy transfer from the delayed fluorescent dopant into the fluorescent dopant is sufficiently generated.

50 [0122] The singlet energy of the first host is greater than that of the delayed fluorescent dopant, and the triplet energy of the first host is greater than that of the delayed fluorescent dopant. In addition, the singlet energy of the second host is greater than that of the fluorescent dopant.

[0123] When not satisfying this condition, a quenching happens at the first and second dopants or an energy transfer from the host to the dopant does not happen, and thus the quantum efficiency of the organic light emitting diode D is reduced.

55 [0124] As mentioned above, since the organic compound of the present disclosure has high triplet energy, the energy transfer efficiency into the delayed fluorescent compound is increased such that the emitting efficiency of the organic light emitting diode D is improved. In addition, since the organic compound of the present disclosure having the n-type property is included in the EML as the host, the quenching problem of the exciton by an interaction between the triplet

exciton of the dopant and the hole-polaron is prevented such that the emitting efficiency of the organic light emitting diode D is further improved.

5 [0125] For example, the second host, which is included in the second layer 344 with the fluorescent dopant, may be same as a material of the HBL 350. In this instance, the second layer 344 may have a hole blocking function with an emission function. Namely, the second layer 344 may serve as a buffer layer for blocking the hole. When the HBL 350 is omitted, the second layer 344 serves as an emitting layer and a hole blocking layer.

10 [0126] When the first layer 342 includes the fluorescent dopant and the second layer 344 includes the delayed fluorescent dopant, the first host of the first layer 342 may be same as a material of the EBL 330. In this instance, the first layer 342 may have an electron blocking function with an emission function. Namely, the first layer 342 may serve as a buffer layer for blocking the electron. When the EBL 330 is omitted, the first layer 342 serves as an emitting layer and an electron blocking layer.

[0127] FIG. 8 is a schematic cross-sectional view of an organic light emitting diode of the present disclosure.

15 [0128] As shown in FIG. 8, an organic light emitting diode D includes the first and second substrates 160 and 164, which face each other, and the organic emitting layer 162 therebetween. The organic emitting layer 162 includes an EML 440, which includes first to third layers 442, 444 and 446 and is positioned between the first and second electrodes 160 and 164, a HTL 420 between the first electrode 160 and the EML 440 and an ETL 460 between the second electrode 164 and the EML 440.

[0129] In addition, the organic emitting layer 162 may further include a HIL 410 between the first electrode 160 and the HTL 420 and an EIL 470 between the second electrode 164 and the ETL 460.

20 [0130] Moreover, the organic emitting layer 162 may further include an EBL 430 between the HTL 420 and the EML 440 and a HBL 450 between the EML 440 and the ETL 460.

[0131] In the EML 440, the first layer 442 is positioned between the second layer 444 and the third layer 446. Namely, the second layer 444 is positioned between the EBL 430 and the first layer 442, and the third layer 446 is positioned between the first layer 442 and the HBL 450.

25 [0132] The first layer 442 (e.g., a first emitting material layer) may include the organic compound of the present disclosure as a first host and a delayed fluorescent dopant as a first dopant, and the second layer 344 (e.g., a second emitting material layer) may include a second host and a fluorescent dopant as a second dopant. The third layer 446 (e.g., a third emitting material layer) may include a third host and a fluorescent dopant as a third dopant. The fluorescent dopant in the second and third layers 444 and 446 may be same or different. The second and third hosts may be the organic compound of the present disclosure. The delayed fluorescent dopant has a singlet energy being larger than the fluorescent dopant.

[0133] In the organic light emitting diode D, the singlet energy and the triplet energy of the delayed fluorescent dopant are transferred into the fluorescent dopant in the second layer 444 and/or the third layer 446 such that the emission is generated from the fluorescent dopant.

35 [0134] In each of the first to third layers 442, 444 and 446, the first to third hosts may have a percentage by weight being larger than the first to third dopants, respectively. In addition, the percentage by weight of the delayed fluorescent dopant (i.e., the first dopant) in the first layer 442 may be greater than that of each of the fluorescent dopant (i.e., the second dopant) in the second layer 444 and the fluorescent dopant (i.e., the third dopant) in the third layer 446.

40 [0135] The singlet energy of the first host is greater than that of the delayed fluorescent dopant, and the triplet energy of the first host is greater than that of the delayed fluorescent dopant. In addition, the singlet energy of the second host is greater than that of the fluorescent dopant in the second layer 444, and the singlet energy of the third host is greater than that of the fluorescent dopant in the third layer 446.

45 [0136] As mentioned above, since the organic compound of the present disclosure has high triplet energy, the energy transfer efficiency into the delayed fluorescent compound is increased such that the emitting efficiency of the organic light emitting diode D is improved. In addition, since the organic compound of the present disclosure having the n-type property is included in the EML as the host, the quenching problem of the exciton by an interaction between the triplet exciton of the dopant and the hole-polaron is prevented such that the emitting efficiency of the organic light emitting diode D is further improved.

50 [0137] For example, the second host in the second layer 444 may be same as a material of the EBL 430. In this instance, the second layer 444 may have an electron blocking function with an emission function. Namely, the second layer 444 may serve as a buffer layer for blocking the electron. When the EBL 430 is omitted, the second layer 444 serves as an emitting layer and an electron blocking layer.

55 [0138] The third host in the third layer 446 may be same as a material of the HBL 450. In this instance, the third layer 446 may have a hole blocking function with an emission function. Namely, the third layer 446 may serve as a buffer layer for blocking the hole. When the HBL 450 is omitted, the third layer 446 serves as an emitting layer and a hole blocking layer.

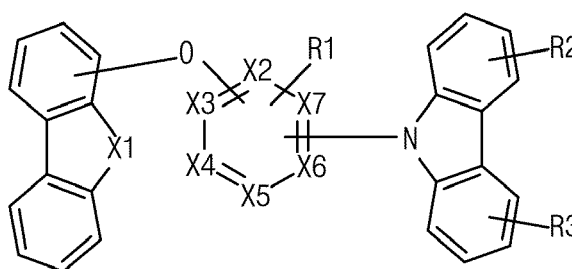
[0139] The second host in the second layer 444 may be same as a material of the EBL 430, and the third host in the third layer 446 may be same as a material of the HBL 450. In this instance, the second layer 444 may have an electron

blocking function with an emission function, and the third layer 446 may have a hole blocking function with an emission function. Namely, the second layer 444 may serve as a buffer layer for blocking the electron, and the third layer 446 may serve as a buffer layer for blocking the hole. When the EBL 430 and the HBL 450 are omitted, the second layer 444 serves as an emitting layer and an electron blocking layer and the third layer 446 serves as an emitting layer and a hole blocking layer.

Claims

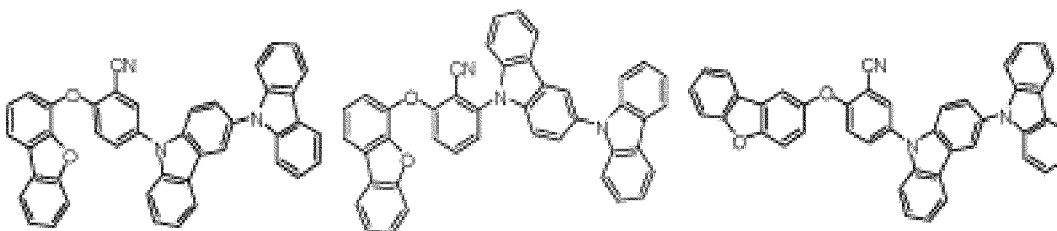
1. An organic compound of Formula 1:

[Formula 1]



wherein X1 is selected from the group consisting of oxygen and sulfur, and each of X2 to X7 is independently selected from the group consisting of carbon and nitrogen, and wherein R1 is selected from the group consisting of hydrogen and cyano group, and each of R2 and R3 is independently selected from the group consisting of hydrogen and heteroaryl group.

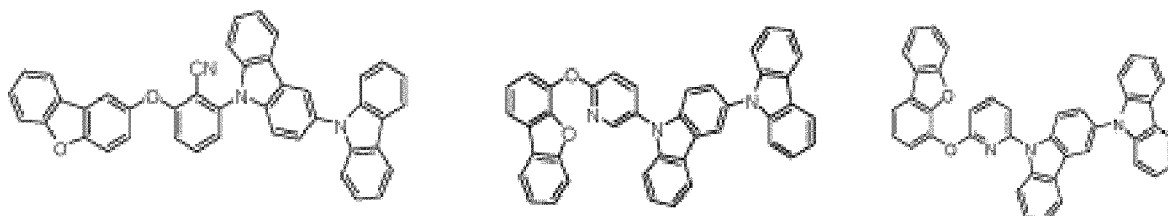
2. The organic compound according to claim 1, wherein the organic compound is selected from the group consisting of:



compound 1

compound 2

compound 3

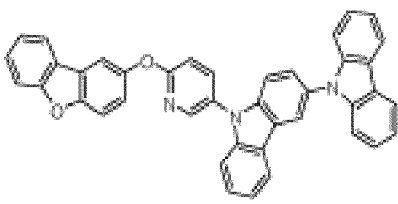


compound 4

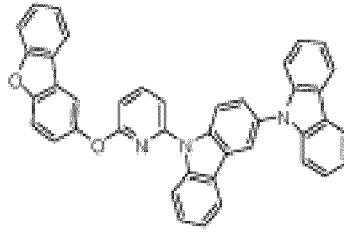
compound 5

compound 6

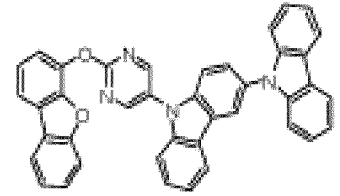
5



compound 7



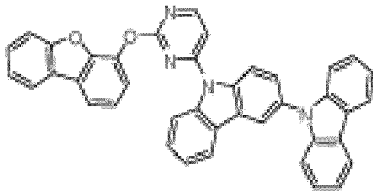
compound 8



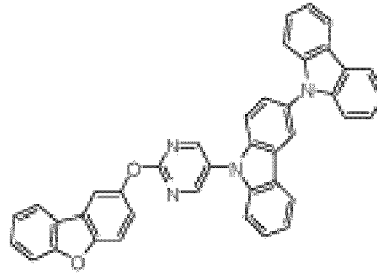
compound 9

10

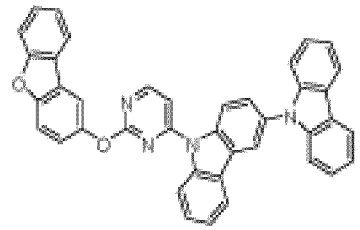
15



compound 10



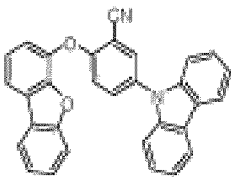
compound 11



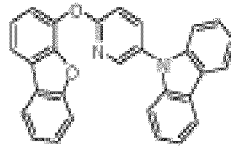
compound 12

20

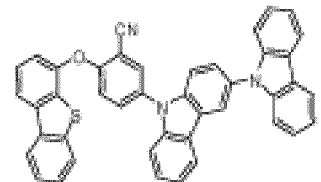
25



compound 13



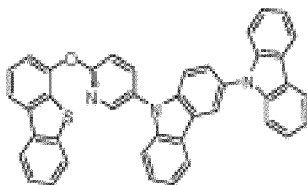
compound 14



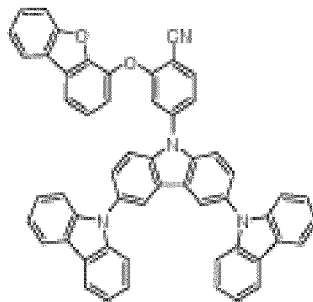
compound 15

30

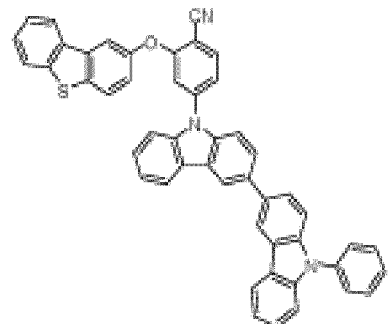
35



compound 16



compound 17



compound 18

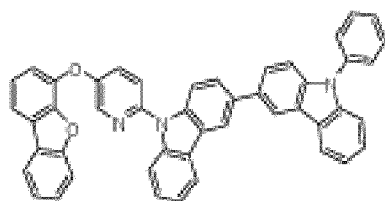
40

45

50

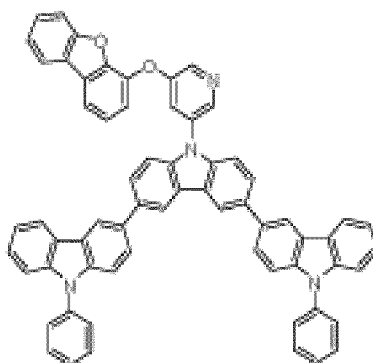
55

5

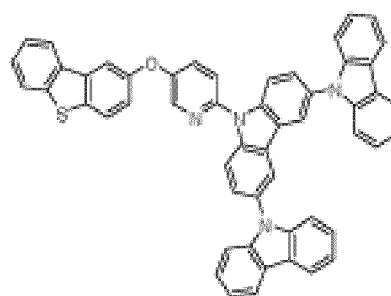


compound 19

10

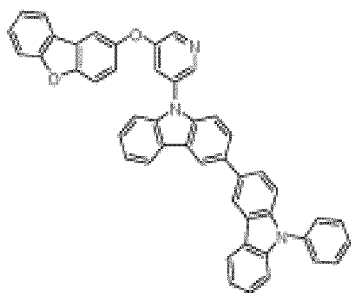


compound 20



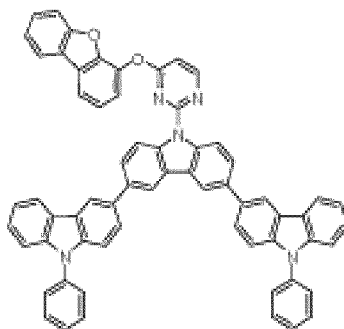
compound 21

15



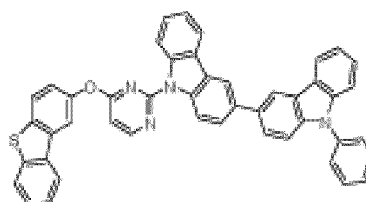
compound 22

20



compound 23

25



compound 24

3. An organic light emitting diode, comprising:

30

- a first electrode;
- a second electrode facing the first electrode; and
- a first emitting material layer between the first and second electrodes and including an organic compound of claim 1 or 2.

35

4. The organic light emitting diode according to claim 3, wherein the organic compound is used a first host, and the first emitting material layer further includes a delayed fluorescent compound as a first dopant.

40

5. The organic light emitting diode according to claim 4, wherein the first emitting material layer further includes a fluorescent compound as a second dopant, and a singlet energy of the first dopant is greater than a singlet energy of the second dopant.

45

6. The organic light emitting diode according to claim 5, wherein a triplet energy of the first dopant is smaller than a triplet energy of the first host and greater than a triplet energy of the second dopant.

50

7. The organic light emitting diode according to claim 3, further comprising:  
a second emitting material layer including a second host and a fluorescent compound as a second dopant and positioned between the first electrode and the first emitting material layer.

55

8. The organic light emitting diode according to claim 7, further comprising:  
an electron blocking layer between the first electrode and the second emitting material layer, wherein the second host is same as a material of the electron blocking layer.

9. The organic light emitting diode according to claim 7, further comprising:  
a third emitting material layer including a third host and a fluorescent compound as a third dopant and positioned between the second electrode and the first emitting material layer.

10. The organic light emitting diode according to claim 9, further comprising:

a hole blocking layer between the second electrode and the third emitting material layer,  
wherein the third host is same as a material of the hole blocking layer.

5

11. The organic light emitting diode according to claim 7, wherein a singlet energy of the first dopant is greater than a singlet energy of the second dopant.

12. The organic light emitting diode according to claim 3, further comprising:

10

a hole transporting layer between the first electrode and the first emitting material layer;  
a hole injection layer between the first electrode and the hole transporting layer;  
an electron blocking layer between the hole transporting layer and the first emitting material layer;  
an electron transporting layer between the first emitting material layer and the second electrode;  
an electron injection layer between the electron transporting layer and the second electrode; and  
a hole blocking layer between the first emitting material layer and the electron transporting layer,  
wherein the organic compound is used as a host in the first emitting material layer, and the first emitting material layer further includes a dopant.

15

13. The organic light emitting diode according to claim 7, wherein the second host is the organic compound of claim 1 or 2.

20

14. The organic light emitting diode according to claim 9, wherein each of the second and third hosts is the organic compound of claim 1 or 2.

15. An organic light emitting display device, comprising:

25

a substrate;  
an organic light emitting diode of claim 3 disposed on the substrate;  
a thin film transistor positioned between the substrate and the organic light emitting diode and connected to the organic light emitting diode.

30

35

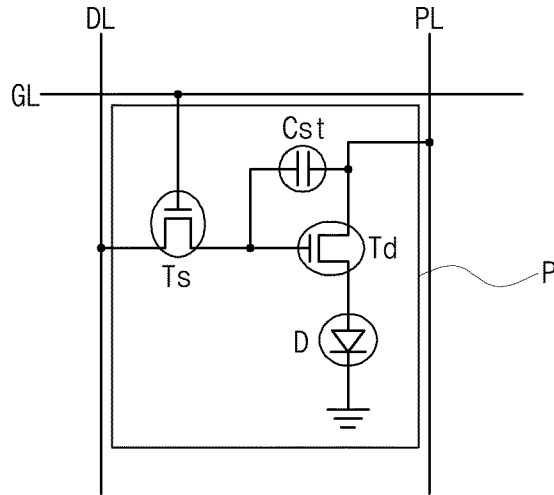
40

45

50

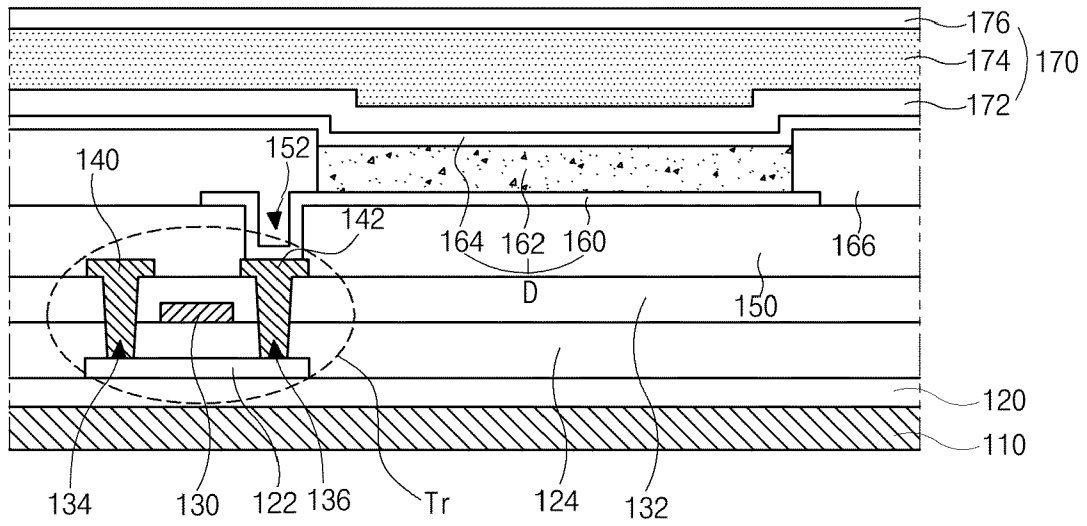
55

**FIG. 1**

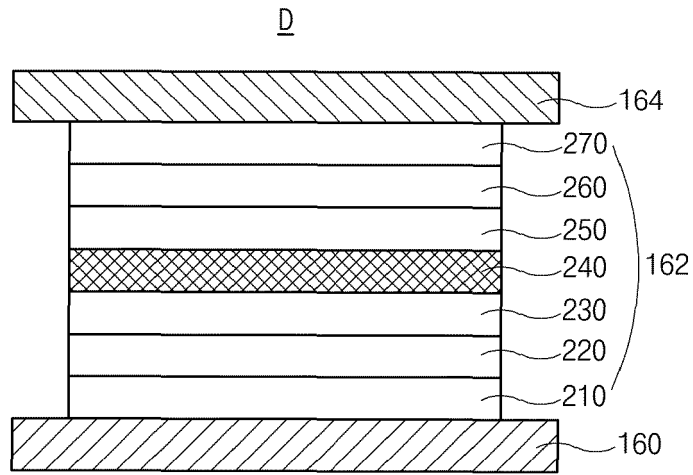


**FIG. 2**

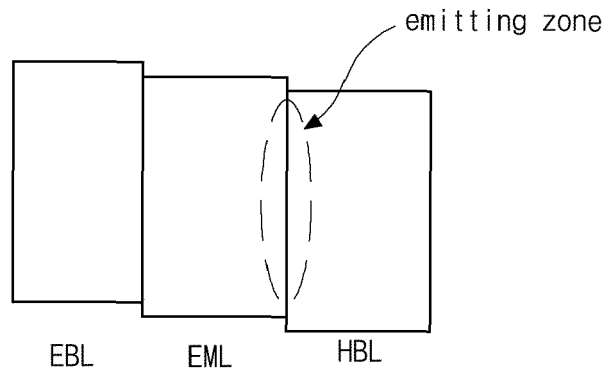
100



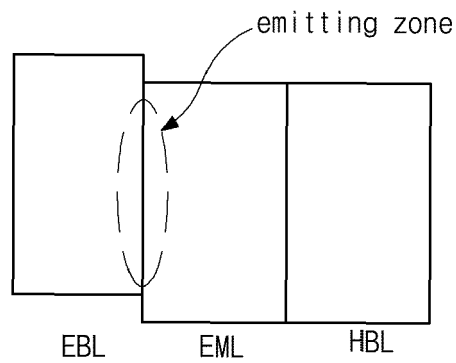
**FIG. 3**



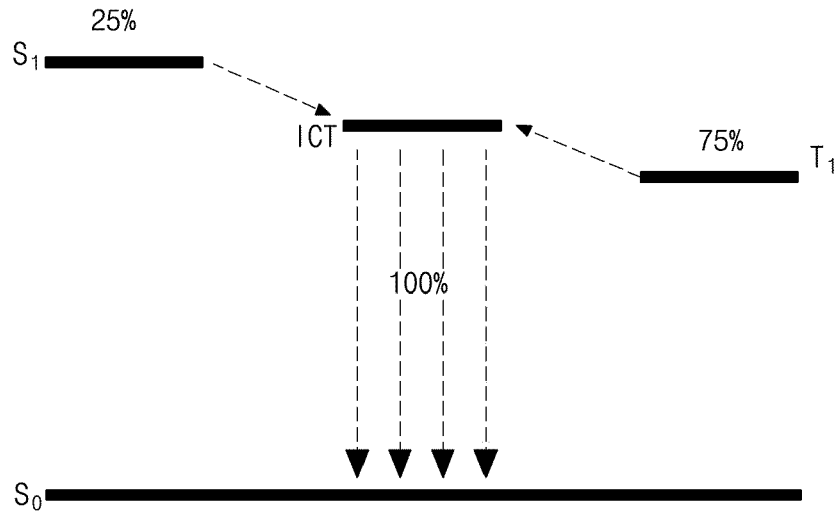
**FIG. 4A**



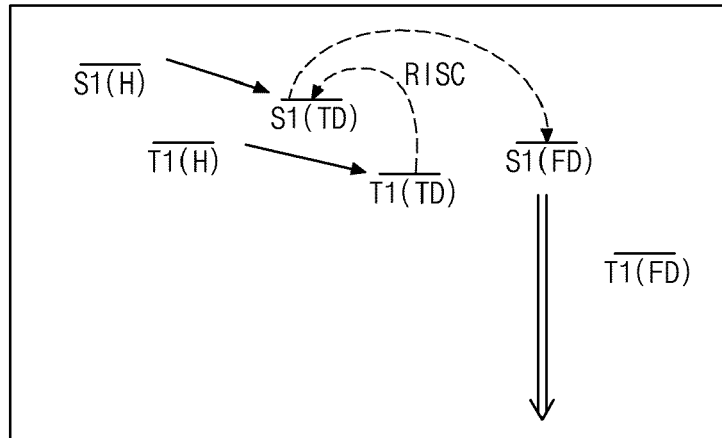
**FIG. 4B**



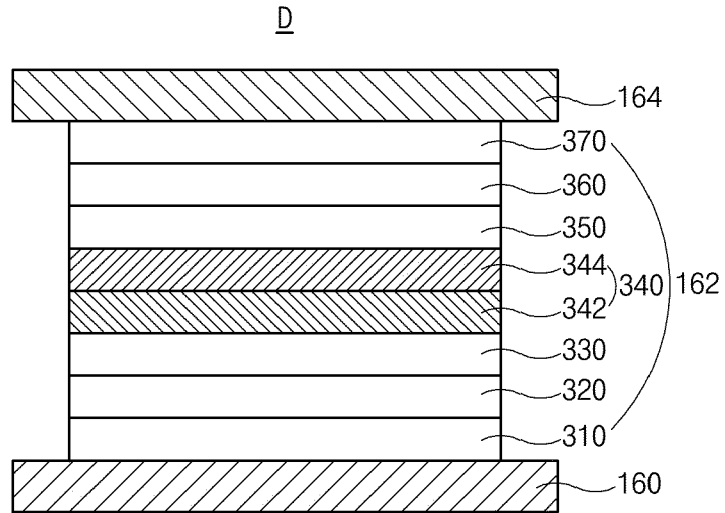
**FIG. 5**



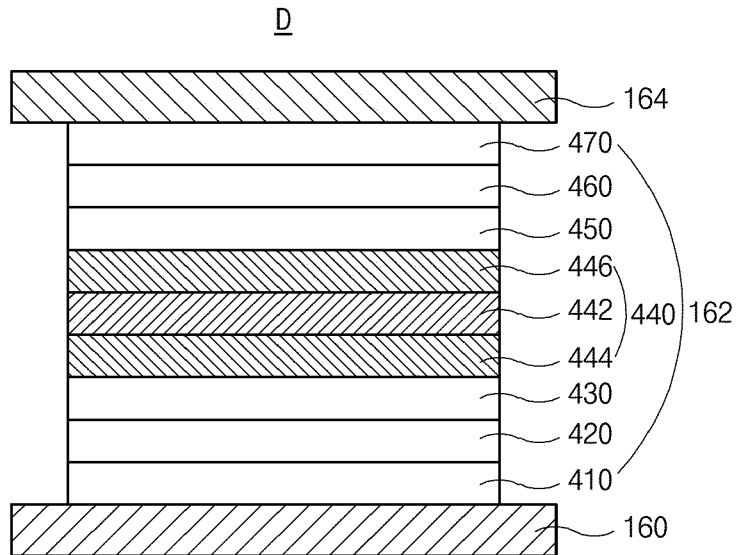
**FIG. 6**



**FIG. 7**



**FIG. 8**





EUROPEAN SEARCH REPORT

Application Number  
EP 19 18 7595

5

10

15

20

25

30

35

40

45

50

55

DOCUMENTS CONSIDERED TO BE RELEVANT			
Category	Citation of document with indication, where appropriate, of relevant passages	Relevant to claim	CLASSIFICATION OF THE APPLICATION (IPC)
X	WO 2017/115753 A1 (KONICA MINOLTA INC [JP]) 6 July 2017 (2017-07-06)	1,3-15	INV. H01L51/54
A	* page 30, paragraphs 1,127,138,149; figure 3; compounds T-91 *	2	
X	JP 2010 021336 A (KONICA MINOLTA HOLDINGS INC) 28 January 2010 (2010-01-28)	1	
A	* page 23; compounds H-26 *		
	-----		
X	JP 2010 021336 A (KONICA MINOLTA HOLDINGS INC) 28 January 2010 (2010-01-28)	1	
	* page 23; compounds H-26 *		
	-----		
A	KR 2011 0016044 A (SFC CO LTD [KR]) 17 February 2011 (2011-02-17)	1-15	
	* compounds SPH01-SPH102 *		
	-----		
The present search report has been drawn up for all claims			
Place of search		Date of completion of the search	Examiner
The Hague		10 December 2019	Fratiloiu, Silvia
CATEGORY OF CITED DOCUMENTS			
X : particularly relevant if taken alone		T : theory or principle underlying the invention	
Y : particularly relevant if combined with another document of the same category		E : earlier patent document, but published on, or after the filing date	
A : technological background		D : document cited in the application	
O : non-written disclosure		L : document cited for other reasons	
P : intermediate document		& : member of the same patent family, corresponding document	

EPO FORM 1503 03/02 (P04C01)

**ANNEX TO THE EUROPEAN SEARCH REPORT  
ON EUROPEAN PATENT APPLICATION NO.**

EP 19 18 7595

5

This annex lists the patent family members relating to the patent documents cited in the above-mentioned European search report. The members are as contained in the European Patent Office EDP file on The European Patent Office is in no way liable for these particulars which are merely given for the purpose of information.

10-12-2019

10

Patent document cited in search report	Publication date	Patent family member(s)	Publication date
WO 2017115753 A1	06-07-2017	JP WO2017115753 A1 WO 2017115753 A1	18-10-2018 06-07-2017
-----	-----	-----	-----
JP 2010021336 A	28-01-2010	NONE	
-----	-----	-----	-----
KR 20110016044 A	17-02-2011	NONE	
-----	-----	-----	-----

15

20

25

30

35

40

45

50

55

EPO FORM P0459

For more details about this annex : see Official Journal of the European Patent Office, No. 12/82

**REFERENCES CITED IN THE DESCRIPTION**

*This list of references cited by the applicant is for the reader's convenience only. It does not form part of the European patent document. Even though great care has been taken in compiling the references, errors or omissions cannot be excluded and the EPO disclaims all liability in this regard.*

**Patent documents cited in the description**

- KR 1020180091757 [0001]

专利名称(译)	有机连接和有机发光二极管以及具有有机发光二极管的显示装置		
公开(公告)号	<a href="#">EP3608985A1</a>	公开(公告)日	2020-02-12
申请号	EP2019187595	申请日	2019-07-22
[标]申请(专利权)人(译)	乐金显示有限公司		
申请(专利权)人(译)	LG DISPLAY CO. , LTD.		
当前申请(专利权)人(译)	LG DISPLAY CO. , LTD.		
[标]发明人	YOON KYUNG JIN NOH HYO JIN		
发明人	YOON, KYUNG-JIN NOH, HYO-JIN BAEK, JEONG-EUN		
IPC分类号	H01L51/54		
CPC分类号	C07D405/14 C07D409/14 H01L51/0067 H01L51/0072 H01L51/0073 H01L51/0074 H01L51/5012 C07D405/12 H01L51/5056 H01L51/5072		
优先权	1020180091757 2018-08-07 KR		
外部链接	<a href="#">Espacenet</a>		

摘要(译)

本发明提供下式的有机化合物和有机发光二极管以及包括该有机化合物的OLED装置。

FIG. 1

