



(12) **EUROPEAN PATENT APPLICATION**

(43) Date of publication:  
**02.04.2014 Bulletin 2014/14**

(51) Int Cl.:  
**H01L 27/32<sup>(2006.01)</sup>**

(21) Application number: **13168105.8**

(22) Date of filing: **16.05.2013**

(84) Designated Contracting States:  
**AL AT BE BG CH CY CZ DE DK EE ES FI FR GB GR HR HU IE IS IT LI LT LU LV MC MK MT NL NO PL PT RO RS SE SI SK SM TR**  
 Designated Extension States:  
**BA ME**

(72) Inventors:  
 • **Son, Young Tae**  
**411-821 Goyang-si, Gyeonggi-do (KR)**  
 • **Kim, Jin Wuk**  
**Goyang-si, Gyeonggi-do 411-736 (KR)**  
 • **Kim, Wy-Yong**  
**152-785 Seoul (KR)**

(30) Priority: **27.09.2012 KR 20120108349**  
**10.04.2013 KR 20130039167**

(74) Representative: **Ter Meer Steinmeister & Partner**  
**Patentanwälte**  
**Mauerkircherstrasse 45**  
**81679 München (DE)**

(71) Applicant: **LG Display Co., Ltd.**  
**Seoul 150-721 (KR)**

(54) **Organic light emitting display device and method for manufacturing the same**

(57) Disclosed is a method of manufacturing an organic light emitting display device. The method include forming a driving thin film transistor and passivation layer on a substrate, forming a bank layer at a boundary portion between adjacent sub-pixels, on the passivation layer, laminating a first photoresist film on the bank layer, forming a first photoresist pattern by irradiating IR light on the first photoresist film in an area except a first sub-pixel, depositing a first organic emission layer in the first sub-

pixel area exposed by the first photoresist pattern, removing the first photoresist pattern, laminating a second photoresist film on the bank layer, forming a second photoresist pattern by irradiating IR light on the second photoresist film in an area except a second sub-pixel, depositing a second organic emission layer in the second sub-pixel area exposed by the second photoresist pattern, and removing the second photoresist pattern.

**FIG. 6**

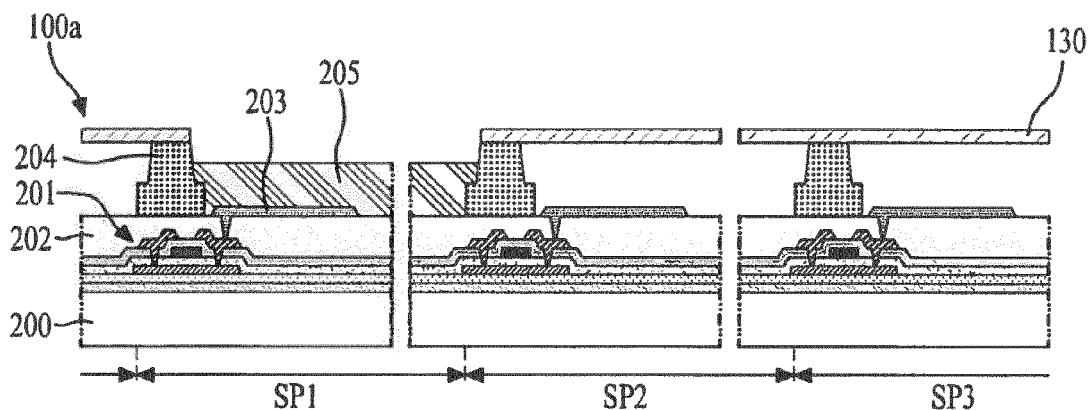

**Description****BACKGROUND****Field of the Invention**

**[0001]** The present invention relates to an organic light emitting display device and a method for manufacturing of an organic light emitting display device, and more particularly, to an organic light emitting display device and a method for manufacturing of an organic light emitting display device applicable to high resolution and a large area.

**Discussion of the Related Art**

**[0002]** As a type of new flat panel display device, organic light emitting display devices including organic light emitting diodes (OLEDs) are self-emitting display devices, and have a better viewing angle and contrast ratio than liquid crystal display (LCD) devices. Also, since the organic light emitting display devices do not need a separate backlight, it is possible to lighten and thin the organic light emitting display devices, and the organic light emitting display devices have excellent power consumption compared to LCD devices and the other flat panel display devices. Furthermore, the organic light emitting display devices are driven with a low direct current (DC) voltage, have a fast response time, and are low in manufacturing cost.

**[0003]** In the organic light emitting display devices, a fine metal mask (FMM) process, an inkjet process, a lift-off process, or the like is used for patterning an emission layer between two electrodes disposed on a substrate.

**[0004]** However, due to limitations of mask manufacturing technology, it is difficult to apply the FMM process to a large size and high resolution. That is, when the organic light emitting display device is applied to a large area, a mask sags due to the weight thereof, and thus, it is difficult to form a desired pattern. Also, the spread of organic materials increases due to a separated distance between the mask and a deposition portion, and therefore, it is difficult to realize high resolution. Furthermore, since the inkjet process needs to use a liquid material, the performance of an OLED exposed by a process is degraded. Especially, in the existing methods including an etching process, a disconnection occurs by direct contact between metal and etching solutions, or it is not easy to control an etching depth, causing the decrease in device characteristic.

**[0005]** Also, the lift-off process includes only an exposure operation and a development operation except an etching operation among operations included in a photo masking process, thereby enabling formation of a fine pattern. However, the defect of an emission layer is caused by organic materials used in a removing operation and foreign matters that are formed by strong adhesive strength in an operation of removing a photoresist

pattern, and therefore, the lift-off process still degrades the efficient characteristic of a display device.

**SUMMARY**

5

**[0006]** Accordingly, the present invention is directed to an organic light emitting display device and a method of manufacturing an organic light emitting display device that substantially obviates one or more problems due to limitations and disadvantages of the related art.

10

**[0007]** An aspect of the present invention is directed to an organic light emitting display device and a method of manufacturing an organic light emitting display device that is applicable to high resolution and a large area, and can improve the emission efficiency of a display device.

15

**[0008]** Additional advantages and features of the invention will be set forth in part in the description which follows and in part will become apparent to those having ordinary skill in the art upon examination of the following or may be learned from practice of the invention. The objectives and other advantages of the invention may be realized and attained by the structure particularly pointed out in the written description and claims hereof as well as the appended drawings.

20

25

**[0009]** The general idea of the invention relates to an organic light emitting display device and a method of manufacturing an organic light emitting display device in which a photoresist pattern formed on a bank layer performs a function of a mask, and thus, the damage of the organic emission layer is minimized and the formation of a pattern is facilitated. In particular, the contact of an organic emission layer can be prevented and damage thereof by foreign matters can be minimized.

30

35

**[0010]** To achieve these and other advantages and in accordance with the purpose of the invention, as embodied and broadly described herein, there is provided a method of manufacturing an organic light emitting display device which includes forming on a substrate a bank layer, or bank layer structures. Preferably, the bank layer is formed on an array substrate of an organic light emitting display device including at least one of driving elements, a passivation layer and an electrode. In one example, the bank layer is formed on a passivation layer. However, most preferably, the bank layer is at least partially formed on an electrode. Here, the bank layer may be patterned as a plurality of spacers or pillars at boundary portions between adjacent sub-pixels. Preferably, the bank layer is used as a spacer or dam layer in the completed device.

40

45

50

On the bank layer, a photoresist film may be formed. Preferably, the photoresist film is laminated on the bank layer such that it rests on the bank layer. Hence, the photoresist film may only be in contact with the bank layer. In other words, the photoresist film may bridge between the adjacent bank layer structures. Preferably, the photoresist film is stable enough to maintain a distance defined by the bank layer to the substrate, i. e. without sagging between pillar-like structures of the bank layer. After forming the photoresist film on the bank layer, the

55

photoresist film may be patterned in order to form a photoresist film pattern. Preferably, IR light, e.g. from a laser, is used for forming the photoresist pattern, which is less harmful than UV light. However, also UV light may be used. The pattern may be formed on all areas except for areas corresponding to sub-pixels that are to be filled with organic emission layer. Thus, the photoresist pattern may include openings in the areas of the substrate, in which an organic emission layer is to be formed in the next step. This may be achieved by irradiating light on the areas in which the photoresist pattern is to be formed or by irradiating light on all areas except for the areas in which the photoresist pattern is to be formed, depending on the type of photoresist film. Then, an organic emission layer may be formed in the open areas of the photoresist pattern and subsequently, the photoresist pattern may be removed. Preferably, the organic emission layer is formed or deposited to a height less than the height of the bank layer. By these means, when repeating the steps of laminating a photoresist and forming a photoresist pattern for depositing an organic emission layer in other areas of the substrate, the already deposited emission layer may be prevented to be influenced by this process. In particular, the photoresist film preferably does not contact the already deposited organic emission layer.

**[0011]** Preferably, the steps of laminating a photoresist film on the bank layer, forming a photoresist pattern and depositing an organic emission layer are repeated wherein a different organic emission layer may be formed on different areas of the substrate. For instance, these steps may be repeated in order to deposit organic emission layers for red, green and blue sub-pixels, respectively, on the substrate.

**[0012]** The bank layer may include an insulating material.

**[0013]** The substrate may include driving elements, e.g. driving thin film transistors, switching thin film transistors or compensation circuits. Furthermore, a passivation layer may be formed on the substrate. In this case, an electrode may be formed on the passivation layer in each of the plurality of sub-pixels. Also, the bank layer may be formed on the passivation layer. Preferably, the bank layer is at least partially overlapping with an electrode or formed on the electrode.

**[0014]** According to a preferred embodiment, the photoresist film includes a photoresist composition material, such as a shield layer or organic shield layer. Preferably, the photoresist film includes further a light expansion layer that may selectively absorb light of a predetermined wavelength, converting the light into heat and then expanding with the generated heat energy. Additionally, the photoresist film may include a supporting film for supporting the photoresist composition material. The photoresist composition material may include a resin hardening at a predetermined wavelength and an additive, such as a photo initiator, a photoacid generator and/or binder. In one embodiment, a photoresist film includes a light expansion layer configured to absorb infrared light

and/or a photoresist composition material including an ultraviolet hardening resin.

**[0015]** In one preferred embodiment, the substrate is inverted such that the photoresist film is disposed in a lower portion, and in the inverted state, an irradiated or a non-irradiated portion of the photoresist film is removed for forming the photoresist pattern. That is, the substrate may be turned such that the photoresist film faces downwards, i.e. in direction of the ground. By these means, foreign matter generated by removing a part of the photoresist film will fall downwards due to gravity and thus not on the substrate. This effect may also be achieved by applying suction in a direction pointing away from the substrate, in order to suck off foreign matter generated during formation of the photoresist pattern.

**[0016]** Preferably, when removing the photoresist pattern, the substrate may be inverted such that the deposited organic emission layer is disposed in a lower portion, and in the inverted state, the photoresist pattern may be removed.

**[0017]** According to one particular embodiment, a method of manufacturing an organic light emitting display device which may include at least some of the steps of: forming a driving thin film transistor on a substrate; forming a passivation layer on the driving thin film transistor; forming an anode electrode in each of a plurality of sub-pixels, on the passivation layer; forming a bank layer at a boundary portion between adjacent sub-pixels, on the passivation layer and/or at least partially on an electrode; laminating a photoresist film on the bank layer; irradiating light in an area of the photoresist film; forming a first photoresist pattern by removing the irradiated or non-irradiated photoresist film on a first sub-pixel area; depositing a first organic emission layer in the first sub-pixel area exposed by the first photoresist pattern; and removing the first photoresist pattern. For forming the first photoresist pattern, preferably the substrate may be inverted such that the photoresist film on the bank layer is facing in a downward direction. Moreover, before removing the photoresist pattern, the substrate may be inverted such that the first deposited organic emission layer is disposed in a lower portion. By these means, it can be prevented that foreign matter caused by the formation of the photoresist pattern or by the removal of the photoresist pattern is getting into contact with the emission layer. Preferably, a second photoresist pattern is formed, as described for the first photoresist pattern, having openings on a second sub-pixel area, a second organic emission layer is formed in the second sub-pixel area and the second photoresist pattern is removed.

**[0018]** According to a further aspect of the present invention, an organic light emitting display device is provided manufactured by any one of the methods according to the present invention.

**[0019]** It is to be understood that both the foregoing general description and the following detailed description of the present invention are exemplary and explanatory and are intended to provide further explanation of the

invention as claimed.

### **BRIEF DESCRIPTION OF THE DRAWINGS**

**[0020]** The accompanying drawings, which are included to provide a further understanding of the invention and are incorporated in and constitute a part of this application, illustrate embodiments of the invention and together with the description serve to explain the principle of the invention. In the drawings:

**[0021]** FIG. 1 is a sectional view illustrating a photoresist film according to an embodiment of the present invention;

**[0022]** FIGS. 2 to 8 are sectional views for describing a method of manufacturing an organic light emitting display device using the photoresist film according to an embodiment of the present invention; and

**[0023]** FIGS. 9 to 18 are sectional views for describing a method of manufacturing an organic light emitting display device using the photoresist film according to another embodiment of the present invention.

### **DETAILED DESCRIPTION OF THE INVENTION**

**[0024]** Hereinafter, embodiments of the present invention will be described in detail with reference to the accompanying drawings. Like reference numerals refer to like elements throughout. In the following description, when the detailed description of the relevant known function or configuration is determined to unnecessarily obscure the important point of the present invention, the detailed description is not provided.

**[0025]** FIG. 1 is a sectional view illustrating a photoresist film according to an embodiment of the present invention.

**[0026]** Referring to FIG. 1, a photoresist film 100 according to an embodiment of the present invention includes a supporting film 110, a light expansion layer 120, and a photoresist composition material 130, such as a shielding material, preferably an organic shielding material 130.

**[0027]** In an embodiment, in the photoresist film 100, the light expansion layer 120 may be formed on the supporting film 110, and the organic shielding material 130 may be formed on the light expansion layer 120.

**[0028]** The supporting film 110 protects and supports the light expansion layer 120 and the organic shielding material 130.

**[0029]** The supporting film 110 may include at least one of glass, a transparent film, or a polymer film that has excellent light transmittance. As an example of a suitable type of polymer film, the supporting film 110 may be at least one of a polyester (PS) film, a polyethylene terephthalate (PET) film or a polyethylene naphthalate (PEN) film. However, the supporting film 10 may also be formed of at least one of various materials.

**[0030]** Moreover, the light expansion layer 120 selectively absorbs only infrared (IR) light, converts the IR light

into heat, and then is expanded with generated heat energy.

**[0031]** The light expansion layer 120 may include a material that has excellent properties for absorbing IR light and has a high ability for converting light energy to heat energy. For example, the light expansion layer 120 may include an organic compound such as carbon black, graphite pigment, and/or IR dye, metal such as Al, Sn, Ti or the like, oxide thereof, or a compound thereof.

**[0032]** The organic shielding material 130 is photoresist (PR) that may include an ultraviolet (UV) hardening resin, so that it is not affected by IR light. Optionally, the organic shielding material 130 additionally includes an additive and thus has good elasticity.

**[0033]** The organic shielding material 130 may include a UV hardening resin, and may be an organic compound having an acrylic group and/or a vinyl group. For example, a UV hardening resin may include poly methyl methacrylate (PMMA), butyl methacrylate (BMA), urethane acrylate, and/or poly vinyl alcohol.

**[0034]** In addition to the above-described configuration, the organic shielding material 130 may include at least one of various additives. For example, the organic shielding material 130 may include a photoinitiator and/or a photoacid generator as an additive, and/or may include an additive such as a binder and/or a monomer including the same.

**[0035]** A photoinitiator hardens a binder in irradiating light, thereby increasing a hardening degree of the photoresist film 100. For example, the photoinitiator may include at least one of acetophenone, benzophenone, oxime or the like. The kind or content of the photoinitiator may be adjusted or determined depending on a desired pattern shape or a wavelength range of an exposure process.

**[0036]** A photoacid generator generates acid in irradiating light. For example, the photoacid generator may include triarylsulfonium salts, diaryliodonium salts, sulfonates, or a compound thereof.

**[0037]** A binder acts as a cross linking agent in irradiating light. For example, the binder may include novolak, polyether acrylate, epoxy acrylate, and/or urethane acrylate.

**[0038]** However, the present invention is not limited thereto, and the photoresist film 100 may be formed of at least one of various materials.

**[0039]** The organic shielding material 130 is sprayed or coated on the light expansion layer 120, e.g. using one of an air knife, a roll coater, a spray, a dipping coater, a gravure coater, a spin coater, a bar coater, a doctor blade, and a slit coater, thereby forming the photoresist film 100. Alternatively, it may be designed that the organic shielding material 130 is formed in a film shape and then adhered to the light expansion layer 120. The organic shielding material 130 may have a thickness of 5  $\mu\text{m}$  to 25  $\mu\text{m}$ .

**[0040]** Therefore, the photoresist film 100 according to an embodiment of the present invention may be disposed

on a bank layer 204, for forming a desired pattern. In this case, the photoresist film 100 is laminated such that a top of the bank layer 204 contacts the organic shielding material 130.

**[0041]** Next, a method that forms a desired pattern by laminating the photoresist film 100 according to an embodiment of the present invention and manufactures an organic light emitting display device will now be described in detail.

**[0042]** FIGS. 2 to 8 are sectional views for describing a method of manufacturing an organic light emitting display device using the photoresist film according to an embodiment of the present invention.

**[0043]** As illustrated in FIG. 2, a driving thin film transistor 201, a passivation layer 202, a first electrode 203, and the bank layer 204 are formed on a substrate 200.

**[0044]** In an embodiment, an organic light emitting diode (OLED) includes the first electrode 203, a second electrode (not shown), and a plurality of organic emission layers 205, 206, and 207 formed therebetween. Therefore, a drain of the driving TFT 201 is electrically connected to the first electrode 203.

**[0045]** In this case, the first electrode 203 is an anode electrode, and is separately formed on the passivation layer 202 to contact the drain, in each of a plurality of sub-pixels. Here, the first electrode 203 may act as one of a plurality of electrodes included in an OLED, and may be formed of at least one of various conductive materials. Also, the first electrode 203 may be formed as a transparent electrode or a reflective electrode. When the first electrode 203 is used as the transparent electrode, the first electrode 203 may be formed of at least one of ITO, IZO, ZnO, or  $\text{In}_2\text{O}_3$ . When the first electrode 203 is used as the reflective electrode, a reflective film may be formed of at least one of Ag, Mg, Al, Pt, Pd, Au, Ni, Nd, Ir, and Cr and a compound thereof, and then, the first electrode 203 may be formed of at least one of ITO, IZO, ZnO, or  $\text{In}_2\text{O}_3$  on the reflective film.

**[0046]** Although not shown, the second electrode (not shown) is formed over the substrate 200, on the organic emission layers 205, 206 and 207. Here, the second electrode may be formed as a transparent electrode or a reflective electrode like the first electrode 203. When the second electrode is used as the transparent electrode, the OLED may include: a layer that is formed of at least one of Li, Ca, LiF/Ca, LiF/Al, Al, Mg, or a compound thereof and an assistant electrode or a bus electrode line that is formed of a transparent-electrode material, such as ITO, IZO, ZnO, and/or  $\text{In}_2\text{O}_3$ , on the layer. Also, when the second electrode is used as the reflective electrode, the second electrode may be formed by depositing at least one of Li, Ca, LiF/Ca, LiF/Al, Al, Mg, or a compound thereof over the substrate 200.

**[0047]** The organic emission layers 205, 206, and 207 are patterned and formed in correspondence with respective sub-pixel areas SP1 to SP3. Here, the organic emission layers 205, 206, and 207 may be formed as a single layer of a light emitting material, or formed as a

multilayer including at least one of a hole injection layer, a hole transport layer, an emission layer (emitting material layer), an electron transport layer, and an electron injection layer for enhancing emission efficiency.

**[0048]** Here, the hole injection layer enables a hole to be smoothly injected from the first electrode 203 into the emission layer, and may be formed of at least one of copper phthalocyanine (CuPc), poly(3,4)-ethylenedioxythiophene (PEDOT), polyaniline (PANI), and N,N-dinaphthyl-N,N'-diphenyl benzidine (NPD).

**[0049]** The hole transport layer easily transports a hole to the emission layer, and moreover prevents an electron, generated from the cathode, from being moved to the emission area, thus increasing emission efficiency. That is, the hole transport layer enables the smooth transport of a hole, and may be formed of at least one of N,N-dinaphthyl-N,N'-diphenyl benzidine (NPD), N,N'-bis-(3-methylphenyl)-N,N'-bis-(phenyl)-benzidine (TPD), s-TAD, and 4,4',4''-Tris(N-3-methylphenyl-N-phenyl-amino)-triphenylamine (MTDATA).

**[0050]** The emission layer may include a host and a dopant. Also, the emission layer may be formed of a light emitting material for emitting red light, green light, blue light, or white light, or formed of a phosphor material or a fluorescent material. In a description on such light emitting materials, various materials will be described with reference to FIG. 6.

**[0051]** The electron transport layer enables the smooth transport of an electron, and may be formed of at least one of tris(8-hydroxyquinolino) aluminum (Alq3), PBD, TAZ, spiro-PBD, BAq, and SAq.

**[0052]** The electron injection layer enables the smooth injection of an electron, and may be formed of at least one of tris(8-hydroxyquinolino) aluminum (Alq3), PBD, TAZ, LiF, spiro-PBD, BAq, and SAq.

**[0053]** The bank layer 204 may be patterned in order for a partial region of the first electrode 203 to be exposed, and at least partially formed in each of the sub-pixel areas SP1 to SP3 on the first electrode 203. That is, by forming the bank layer 204, an opening in a photoresist pattern may be formed on the first electrode 203, and the organic emission layers 205, 206, and 207 may be formed inside the opening.

**[0054]** Here, the bank layer 204 may be formed of an insulating material such as silicon oxide ( $\text{SiO}_x$ ) or silicon nitride ( $\text{SiN}_x$ ). In addition, the bank layer 204 may be formed of at least one of various insulating organic materials.

**[0055]** Therefore, in the organic light emitting display device, when a certain voltage is applied to the first electrode 203 and the second electrode (not shown) to according to a selected color signal, a hole and an electron are transported to the organic emission layers 205, 206, and 207 to generate an exciton, and, when the exciton is shifted from an excited state to a base state, visible light is emitted. At this point, the emitted light is transferred to the outside through the second transparent electrode (not shown), thereby realizing an image.

**[0056]** Subsequently, an encapsulation operation may be performed for protecting an OLED of each sub-pixel from the outside. In the present invention, a general thin film encapsulation process may be used. The thin film encapsulation process is known technology, and thus, its detailed description is not provided in the specification.

**[0057]** As described above, the method of manufacturing the organic light emitting display device (for example, OLED) has been described above as an example. However, in addition to a switching thin film transistor (not shown) and a driving thin film transistor that are formed in a unit pixel, a compensation circuit for compensating for a threshold voltage of the driving thin film transistor may be provided. Namely, a plurality of driving elements may be additionally formed. The driving elements may be freely disposed in a pixel.

**[0058]** Subsequently, as illustrated in FIG. 3, the photoresist film 100 is laminated on the bank layer 204.

**[0059]** In an embodiment, the photoresist film 100 including the supporting film 110, the light expansion layer 120, and the organic shielding material 130 is disposed to face an upper region of the bank layer 204 formed on the passivation layer 202, and then laminated uniformly. In this case, lamination is uniformly performed such that the photoresist film 100 does not sag in an opening formed due to the bank layer 204.

**[0060]** Although not shown, an assistant bank layer (not shown) may be further formed between adjacent bank layers 204 in order for the photoresist film 100 to be uniformly laminated.

**[0061]** Subsequently, as illustrated in FIGS. 4 and 5, a photoresist pattern 100a is formed by irradiating IR light on the photoresist film 100.

**[0062]** In an embodiment, in irradiating a laser on a top of the photoresist film 100, an IR laser is irradiated on only an area except for an area in which an organic emission layer is to be provided, e.g. except the first sub-pixel area SP1 in Fig. 4. Therefore, the photoresist pattern 100a has an opening for depositing an organic emission layer with a red light emitting material.

**[0063]** In this case, an IR laser having a wavelength of 1000 nm or more is irradiated on a scan region in the top of the photoresist film 100 by using a scan process or a separate mask. IR irradiation may be designed to have a constant energy density, wavelength, and irradiating time, but, for example, IR irradiation may be designed to have an energy density and a irradiating time at a wavelength band of 1000 nm or more. Of course, also other wavelengths can be used for irradiation, depending on the composition of the photoresist film 100.

**[0064]** Therefore, in the photoresist film 100, volume expansion due to heat is performed in only a region on which a laser has been irradiated, and layer detachment is performed. That is, volume expansion is performed in only the light expansion layer 120 on which a laser has been irradiated, and the light expansion layer 120 is detached from the organic shielding material 130. Here, layer detachment between the light expansion layer 120

and the organic shielding material 130 is not performed in a region (i.e., the first sub-pixel area SP1) on which a laser is not irradiated. Therefore, layer detachment is performed in only a region (i.e., a region on which a laser has been irradiated) except the first sub-pixel SP1, and, by removing the light expansion layer 120 in which layer detachment has occurred, the photoresist pattern 100a is left in only a region on which a laser has been irradiated.

**[0065]** As a result, the photoresist pattern 100a in which an opening is formed in a first sub-pixel area (SP1 of FIG. 8) may be designed so as to enable the deposition of a red, blue, or green organic emission layer (205 of FIG. 8).

**[0066]** Although not shown, a photoresist pattern in which an opening is formed in a second sub-pixel area (SP2 of FIG. 8) or in a third sub-pixel area (SP3 of FIG. 8) may be designed so as to enable the deposition of a red, blue, or green organic emission layer (206 or 207 of FIG. 8).

**[0067]** In this case, a photoresist pattern may be formed by irradiating an IR laser and separately adjusting a temperature, and an additional process such as temperature adjustment may be variously applied according to characteristic of a photoresist film.

**[0068]** Subsequently, as illustrated in FIG. 6, the organic emission layer 205 is deposited on the first electrode 203 exposed by the photoresist pattern 100a.

**[0069]** In an embodiment, the organic emission layer 205 is deposited with a red light emitting material, on a top of the first electrode 203 exposed by the photoresist pattern 100a, namely, in the first sub-pixel area SP1.

**[0070]** Although not shown, in addition to the red light emitting material, the organic emission layer (206 of FIG. 8) may be deposited with a green light emitting material in the second sub-pixel area SP2, and the organic emission layer (207 of FIG. 8) may be deposited with a blue light emitting material in the third sub-pixel area SP3.

**[0071]** Here, a red light emitting material may include a host material including carbazole biphenyl (CBP) and/or 1,3-bis(carbazol-9-yl) (mCP), and include a phosphor material including a dopant including one or more selected from the group consisting of PIQIr(acac)(bis(1-phenylisoquinoline)acetylacetonate iridium), PQIr(acac)(bis(1-phenylquinoline)acetylacetonate iridium), PQIr(tris(1-phenylquinoline)iridium), and PtOEP(octaethylporphyrin platinum). On the other hand, the red light emitting material may include a phosphor material including PBD:Eu(DBM)3(Phen) and/or Perylene.

**[0072]** A green light emitting material may include a host material including CBP and/or mCP, and may include a phosphor material including a dopant including Ir(ppy)3(fac tris(2-phenylpyridine)iridium). On the other hand, the red light emitting material may include a phosphor material including Alq3(tris(8-hydroxyquinolino)aluminum).

**[0073]** A blue light emitting material may include a host material including CBP and/or mCP, and may include a

phosphor material including a dopant including (4,6-F2ppy)2Irpic and/or L2BD111. On the other hand, the red light emitting material may include a phosphor material including a dopant including one or more selected from the group consisting of spiro-DPVBi, spiro-6P, DSB, DSA, PFO-based polymer, and PPV-based polymer.

**[0074]** For example, the organic emission layer (205 of FIG. 8) may be formed of a low molecular material such as Alq3 (host)/DCJTB (fluorescent dopant), Alq3 (host)/DCM (fluorescent dopant), and/or CBP (host)/PtOEP (phosphor organic metal complex) that is a red light emitting material, and a polymer material such as PFO-based polymer and/or PPV-based polymer. The organic emission layer (206 of FIG. 8) may be formed of a low molecular material such as Alq3, Alq3 (host)/C545t (dopant), and/or CBP (host)/IrPPY (phosphor organic material complex) that is a green light emitting material, and a polymer material such as PFO-based polymer and/or PPV-based polymer. The organic emission layer (207 of FIG. 8) may be formed of a low molecular material such as DPVBi, spiro-DPVBi, spiro-6P, DSB, and/or DSA that is a blue light emitting material, and a polymer material such as PFO-based polymer and/or PPV-based polymer.

**[0075]** Finally, as illustrated in FIGS. 7 and 8, by removing the photoresist pattern 100a, the OLED in which the organic emission layers 205, 206, and 207 are formed on the first electrode 203 is manufactured.

**[0076]** In an embodiment, a separation roller 300 is disposed on the photoresist pattern 100a formed on the bank layer 204, and, by rotating the separation roller 300, the photoresist pattern 100a may be easily removed from the bank layer 204.

**[0077]** In this case, the separation roller 300 may include a detach film having adhesive strength similar to that of a generally used tape. As another example, the photoresist pattern 100a may be easily removed from the bank layer 204 with separation instruments having various sizes or shapes.

**[0078]** According to the present invention, by repeatedly performing the manufacturing method of FIGS. 4 to 7, the organic emission layers 205, 206, and 207 are formed in the respective unit sub-pixels, and, by continuously depositing materials of the hole transport layer as well as the organic emission layer in all corresponding sub-pixels, the OLED may be manufactured.

**[0079]** FIGS. 9 to 18 are sectional views for describing a method of manufacturing an organic light emitting display device using the photoresist film according to another embodiment of the present invention. Here, a description on the configuration that is the same as the configuration of the above-described method of manufacturing an organic light emitting display device using the photoresist film according to the embodiment is not provided or will be briefly described below.

**[0080]** As illustrated in FIG. 9, a driving thin film transistor 201, a passivation layer 202, a first electrode 203, and the bank layer 204 are formed on a substrate 200.

**[0081]** Subsequently, as illustrated in FIG. 10, the photoresist film 100 is laminated on the bank layer 204.

**[0082]** Subsequently, as illustrated in FIGS. 11 and 14, a photoresist pattern 100a is formed by irradiating IR light on the photoresist film 100.

**[0083]** Preferably, the substrate 200 is inverted such that the photoresist film 100 on which IR light is irradiated is disposed in a lower portion, and in the inverted state, the first photoresist pattern 100a is formed by removing a light expansion layer in which layer detachment is created. Here, if the light expansion layer is removed in the inverted state, the falling foreign matter can be removed toward the direction of gravity, and thus, the foreign matter can be prevented from coming to an inside of the sub-pixel area. That is, the defect of an emission layer EML can be improved by preventing the foreign matter, and thus, the efficient characteristic of a device can be enhanced. Additionally, some suction in the lower direction may be applied.

**[0084]** Subsequently, as illustrated in FIG. 15, the organic emission layer 205 is deposited on the first electrode 203 exposed by the photoresist pattern 100a.

**[0085]** Finally, as illustrated in FIGS. 16 to 18, the substrate 200 may be inverted again such that the deposited organic emission layer 205 is disposed in a lower portion, and in the inverted state, a organic light emitting display device, the first electrode 203 of which is formed in the organic emission layers 205, 206 and 207, is manufactured by removing the photoresist pattern 100a.

**[0086]** As described above, in the present invention, the falling foreign matter can be removed toward the direction of gravity by inverting the substrate 200 such that the deposited organic emission layer 205 is disposed in a lower portion, and thus, the foreign matter can be prevented from coming to an inside of the sub-pixel area. That is, the defect of an emission layer EML can be improved by preventing the foreign matter, and thus, the efficient characteristic of a device can be enhanced.

**[0087]** According to the present invention, by repeatedly performing the manufacturing method according to any of the described embodiments, the organic emission layers 205, 206, and 207 are formed in the respective unit sub-pixels, and, by continuously depositing materials of the hole transport layer as well as the organic emission layer in the corresponding sub-pixels for red, green and blue, respectively, the OLED may be manufactured.

**[0088]** Accordingly, in the organic light emitting display device, by introducing the photoresist film according to an embodiment of the present invention, the photoresist pattern formed on the bank layer prevents the contact of the organic emission layer, thus minimizing the damage of the organic emission layer and facilitating the formation of a desired pattern. As a result, the emission characteristic and service life of organic light emitting display device are improved, thus facilitating the manufacturing of the organic light emitting display device and enhancing productivity.

**[0089]** In the method of forming a pattern with the pho-

toresist film according to an embodiment of the present invention, the organic light emitting display device including OLEDs has been exemplified in the specification, but the present invention is not limited thereto. As another example, the present invention may be applied to various display devices such as LCD devices, electrophoresis display (EPD) devices, etc.

**[0090]** According to the present invention, the organic light emitting display device can be applied to high resolution and a large area, and the emission characteristic and service life of organic light emitting display device are improved, thus facilitating the manufacturing of the organic light emitting display device and enhancing productivity.

**[0091]** Moreover, even when the photoresist pattern is formed only one time for each type of sub-pixels, red, green, and blue organic materials and the materials of the HTL and the like may be successively deposited by sub-pixel.

### Claims

1. A method of manufacturing an organic light emitting display device, comprising:

forming a bank layer on a substrate having a plurality of sub-pixels at a boundary portion between adjacent sub-pixels;  
 laminating a photoresist film on the bank layer;  
 forming a photoresist pattern in an area except for predetermined sub-pixels by irradiating light on the photoresist film;  
 depositing an organic emission layer in the predetermined sub-pixel area exposed by the photoresist pattern; and  
 removing the photoresist pattern.

2. The method of claim 1, wherein the steps of laminating a photoresist film on the bank layer; forming a photoresist pattern by irradiating light; depositing an organic emission layer in the predetermined sub-pixel area exposed by the photoresist pattern; and removing the photoresist pattern are repeated for coating a further organic emission layer in different predetermined sub-pixels.

3. The method of claim 1 or 2, wherein the bank layer includes an insulating material.

4. The method of any one of the preceding claims, wherein the substrate includes driving elements including at least one of driving thin film transistors, switching thin film transistors and a compensation circuit.

5. The method of any one of the preceding claims,

wherein the substrate includes a passivation layer and an electrode in each of the plurality of sub-pixels on the passivation layer.

6. The method of any one of the preceding claims, wherein for irradiating light, infrared (IR) or ultraviolet (UV) light is used.

7. The method of any one of the preceding claims, wherein the photoresist film includes a photoresist composition material, a light expansion layer for expanding by selectively absorbing the irradiated light and a supporting film for supporting the light expansion layer and the photoresist composition material.

8. The method of any one of the preceding claims, wherein the photoresist film comprises a photoresist composition material that includes an ultraviolet hardening resin and an additive including at least one of a photoinitiator, a photoacid generator and a binder.

9. The method of any one of the preceding claims, wherein the photoresist film comprises a light expansion layer that includes a material absorbing infrared light and has a high ability for converting light energy into heat.

10. The method of any one of the preceding claims, wherein the photoresist film comprises a supporting film including one of glass, a transparent film or a light-transmissive polymer film.

11. The method of any one of the preceding claims, wherein in the step of forming the photoresist pattern:

light is irradiated on the photoresist film in an area except for the predetermined sub-pixel for removing the photoresist film in the area of the predetermined sub-pixel, or  
 light is irradiated on the photoresist film in the area of the predetermined sub-pixel for removing the photoresist film in the area of the predetermined sub-pixel.

12. The method of any one of the preceding claims, wherein the step of forming the photoresist pattern includes:

inverting the substrate such that the photoresist film is disposed in a lower portion, and in the inverted state, removing an irradiated or a non-irradiated portion of the photoresist film for forming the photoresist pattern.

13. The method of any one of the preceding claims, wherein the step of removing the photoresist pattern includes:

inverting the substrate such that the deposited organic emission layer is disposed in a lower portion, and  
in the inverted state, removing the photoresist pattern.

5

14. The method of any one of the preceding claims, including further:

forming a driving thin film transistor on a substrate; 10  
forming a passivation layer on the driving thin film transistor; and  
forming an anode electrode in each of a plurality of sub-pixels, on the passivation layer, before 15  
forming the bank layer at the boundary portion between adjacent sub-pixels, on the passivation layer.

15. An organic light emitting display device, manufactured by a method according to any one of the preceding claims. 20

25

30

35

40

45

50

55

FIG. 1

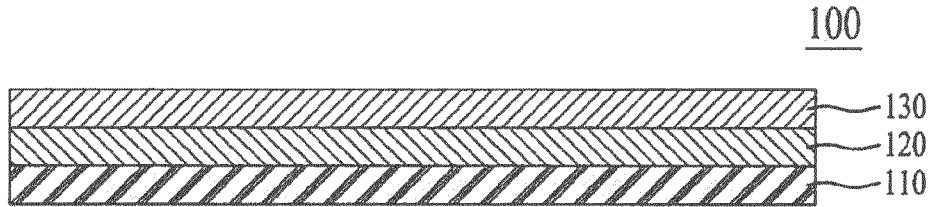

FIG. 2

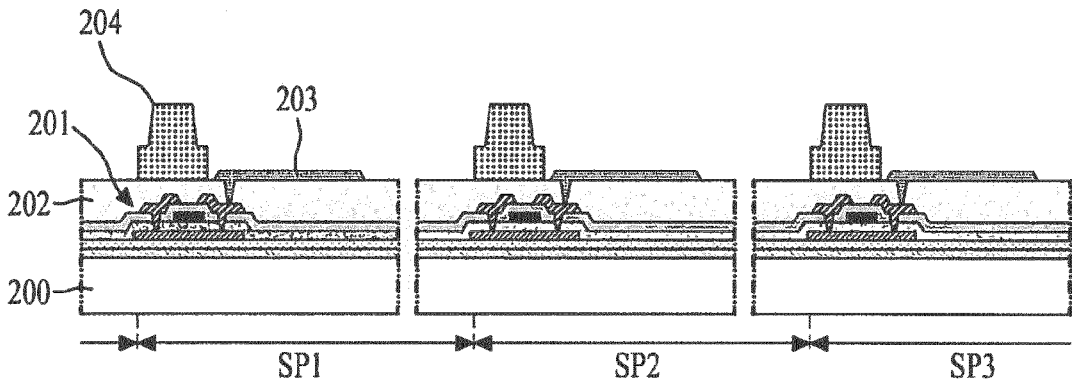

FIG. 3

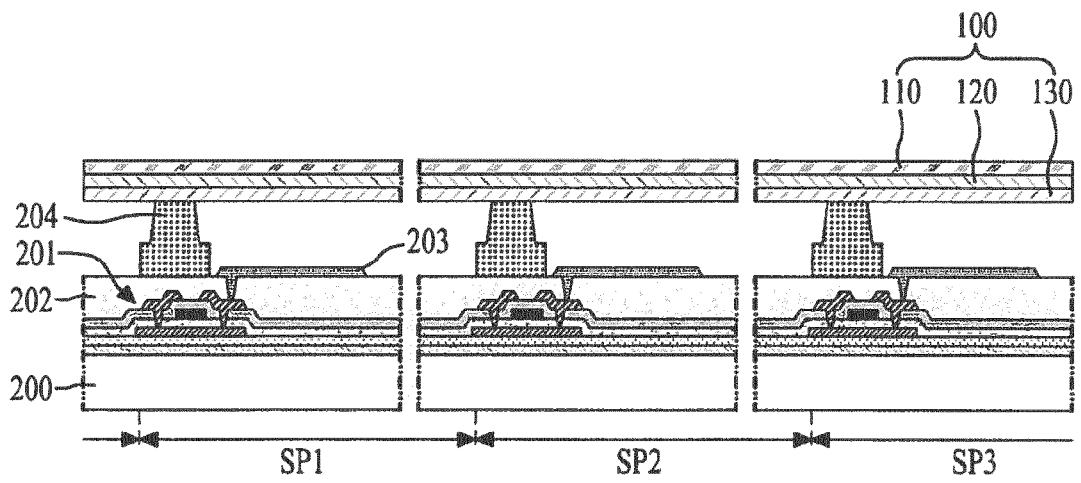

FIG. 4

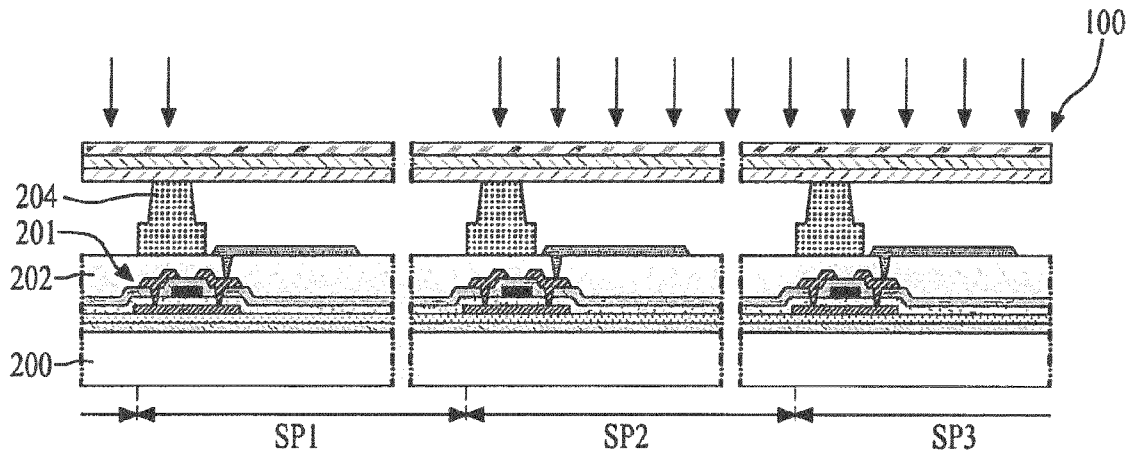

FIG. 5

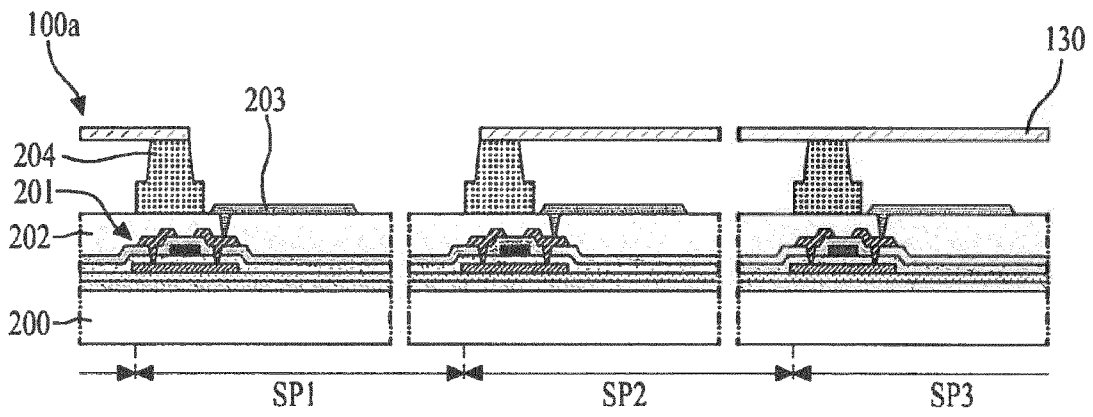

FIG. 6

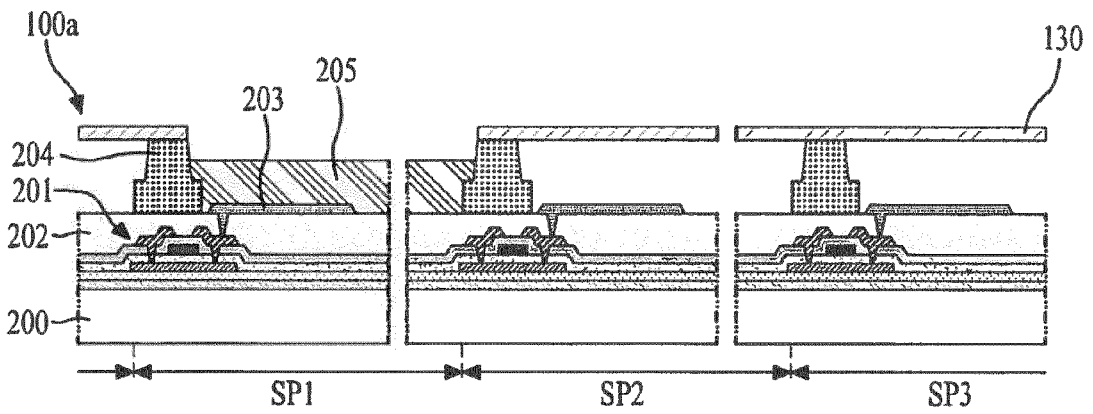

FIG. 7

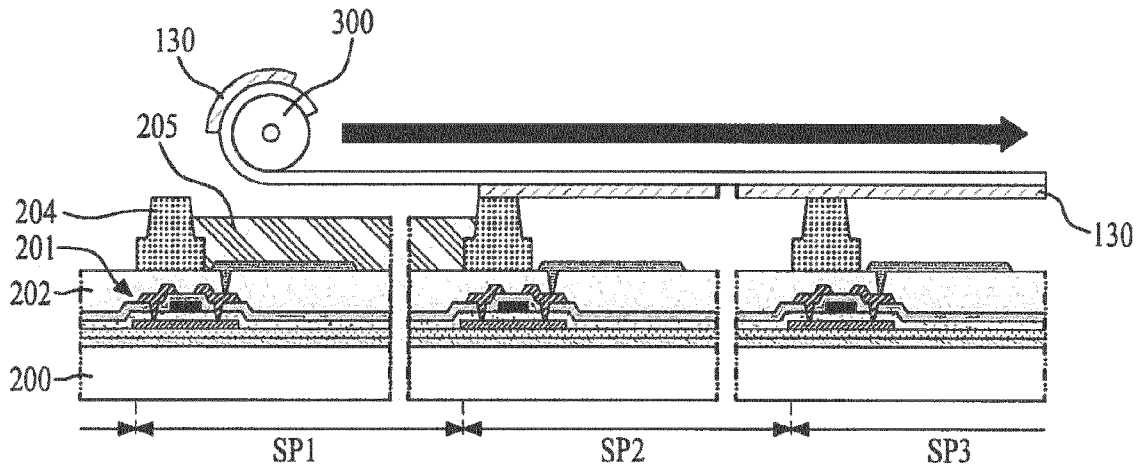

FIG. 8

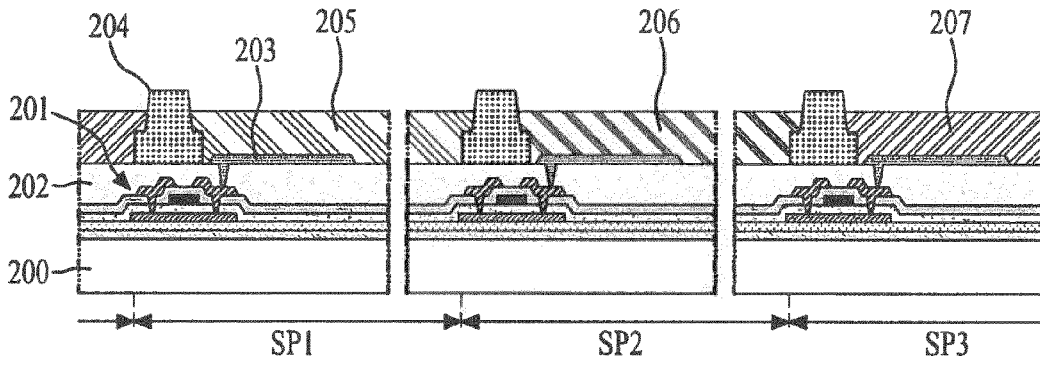

FIG. 9

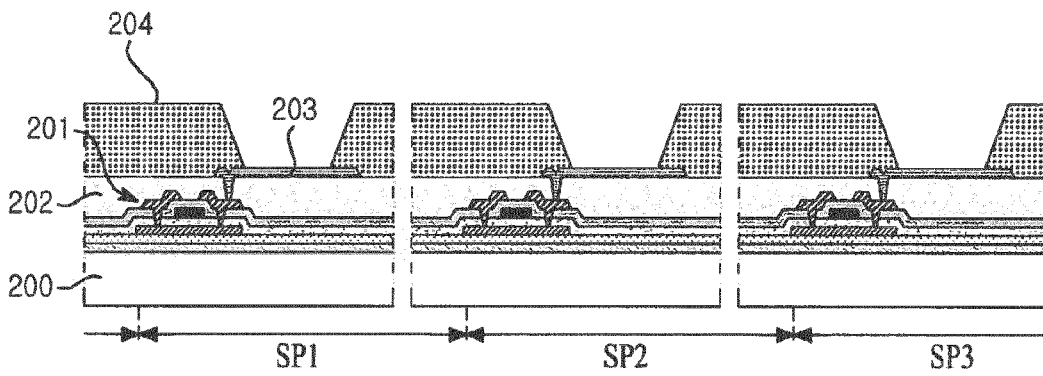

FIG. 10

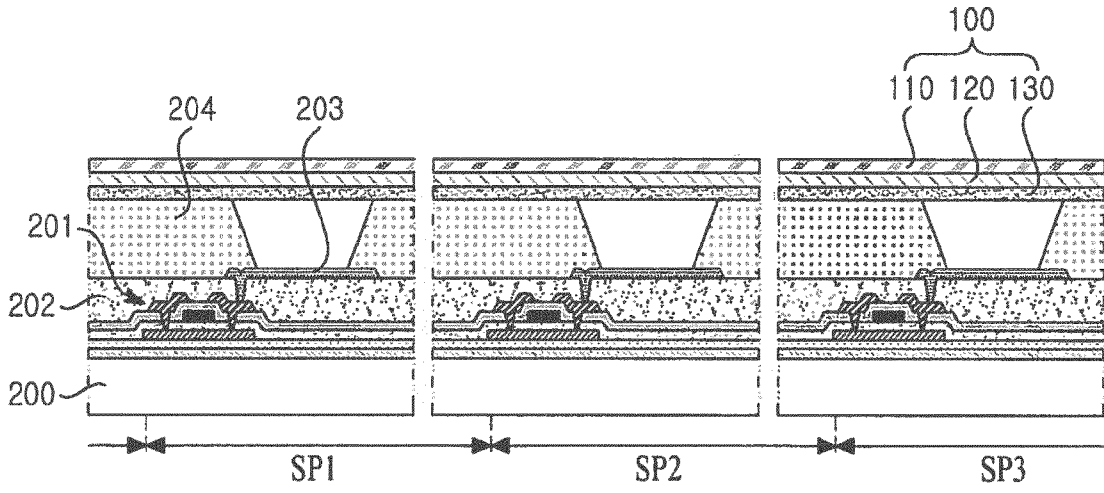

FIG. 11

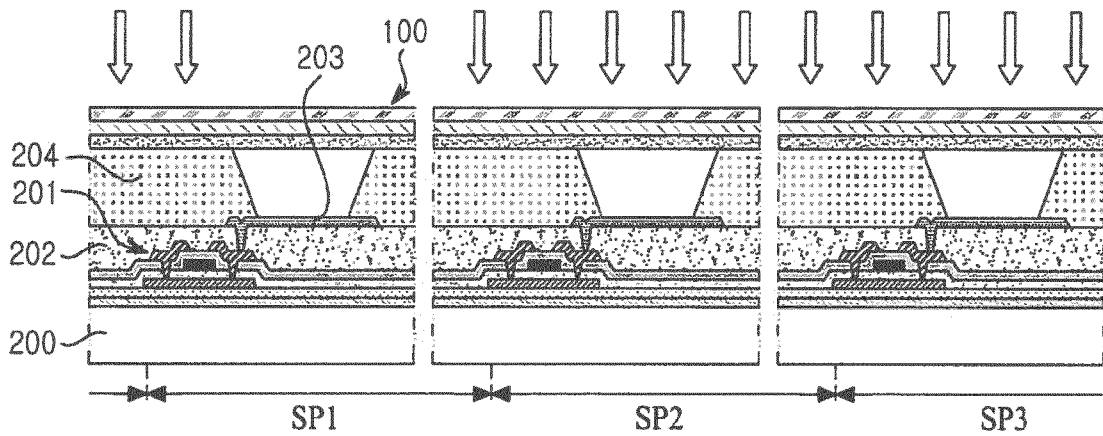

FIG. 12

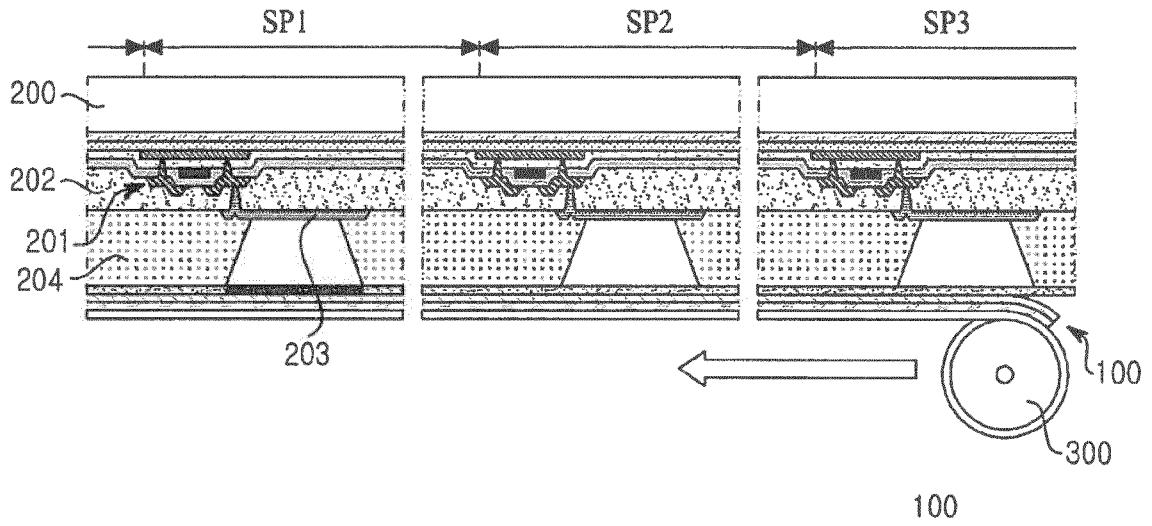

FIG. 13

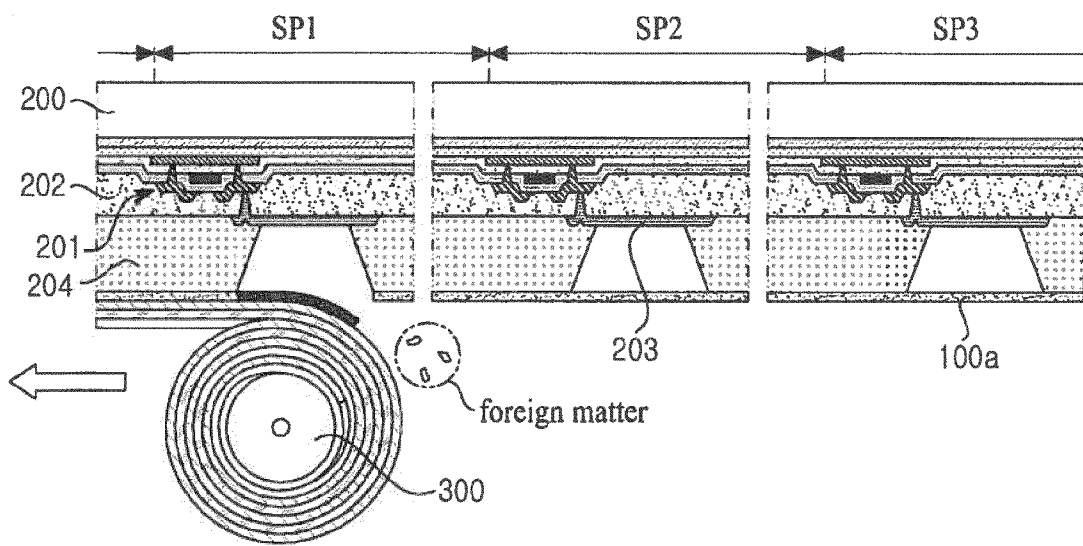

FIG. 14

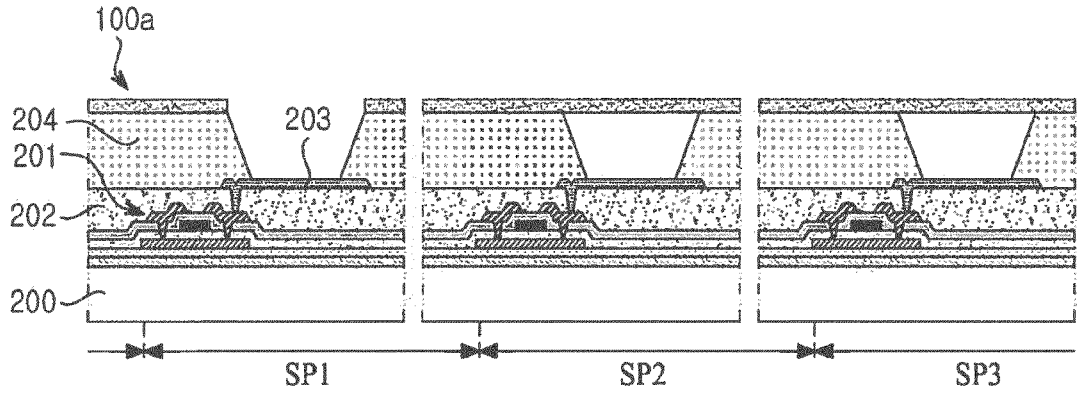

FIG. 15

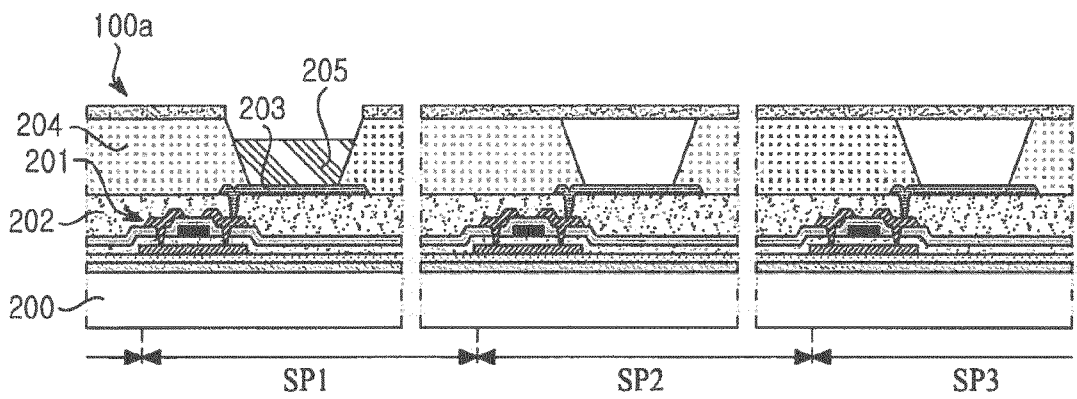

FIG. 16

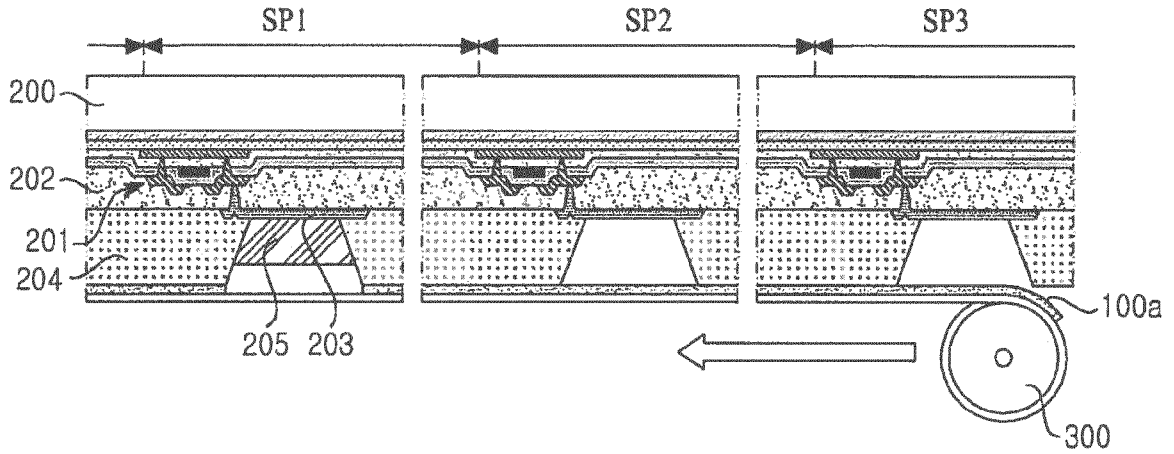

FIG. 17

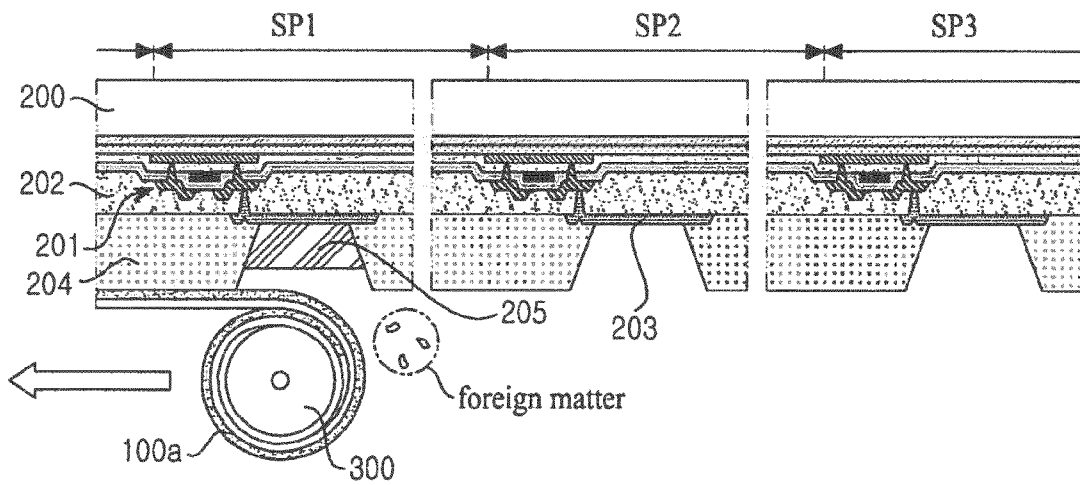
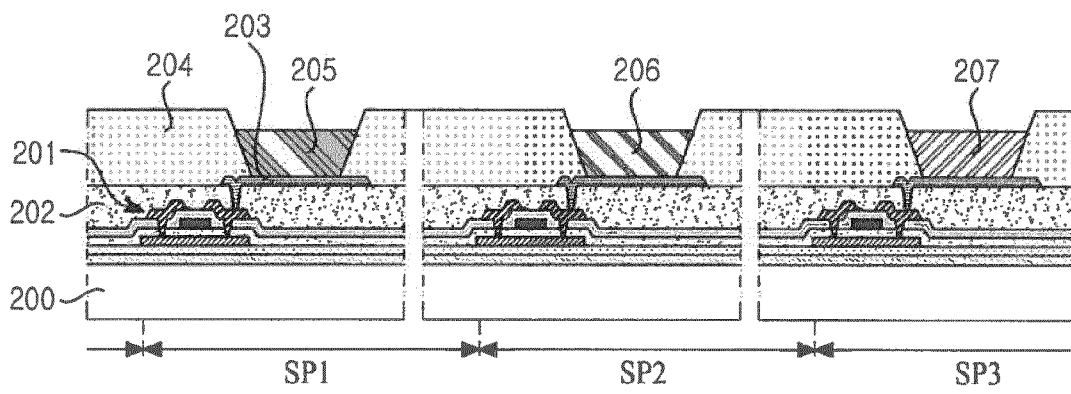

FIG. 18



专利名称(译)	有机发光显示装置及其制造方法		
公开(公告)号	<a href="#">EP2713399A2</a>	公开(公告)日	2014-04-02
申请号	EP2013168105	申请日	2013-05-16
[标]申请(专利权)人(译)	乐金显示有限公司		
申请(专利权)人(译)	LG DISPLAY CO. , LTD.		
当前申请(专利权)人(译)	LG DISPLAY CO. , LTD.		
[标]发明人	SON YOUNG TAE KIM JIN WUK KIM WY YONG		
发明人	SON, YOUNG TAE KIM, JIN WUK KIM, WY-YONG		
IPC分类号	H01L27/32 B41M5/46 G03F7/00 H01L51/56		
CPC分类号	G03F7/0035 H01L27/3246 H01L51/56 H01L2227/323		
优先权	1020120108349 2012-09-27 KR 1020130039167 2013-04-10 KR		
其他公开文献	EP2713399A3		
外部链接	<a href="#">Espacenet</a>		

摘要(译)

公开了一种制造有机发光显示装置的方法。该方法包括在基板上形成驱动薄膜晶体管 and 钝化层，在相邻子像素之间的边界部分处形成堤层，在钝化层上，在堤层上层叠第一光刻胶膜，形成第一光刻胶图案通过在除第一子像素之外的区域中的第一光刻胶膜上照射IR光，在由第一光刻胶图案暴露的第一子像素区域中沉积第一有机发光层，去除第一光刻胶图案，层压第二光刻胶膜在堤层上，通过在除第二子像素之外的区域中的第二光刻胶膜上照射IR光，在由第二光刻胶图案暴露的第二子像素区域中沉积第二有机发光层，形成第二光刻胶图案，以及去除第二光刻胶图案。

