



(11) **EP 2 202 817 A1**

(12) **EUROPEAN PATENT APPLICATION**

(43) Date of publication:  
**30.06.2010 Bulletin 2010/26**

(51) Int Cl.:  
**H01L 51/00 (2006.01)**

(21) Application number: **09175020.8**

(22) Date of filing: **04.11.2009**

(84) Designated Contracting States:  
**AT BE BG CH CY CZ DE DK EE ES FI FR GB GR  
HR HU IE IS IT LI LT LU LV MC MK MT NL NO PL  
PT RO SE SI SK SM TR**  
Designated Extension States:  
**AL BA RS**

(30) Priority: **24.12.2008 KR 20080133274**  
**07.07.2009 KR 20090061771**

(71) Applicant: **LG Display Co., Ltd.**  
**Youngdungpo-gu,**  
**Seoul (KR)**

(72) Inventors:  
• **Lee, Kyung-Hoon**  
**Gyeonggi-do (KR)**  
• **Park, Jong-Hyun**  
**Seoul (KR)**  
• **Park, Tae-Han**  
**Seoul (KR)**  
• **Jeong, Hyun-Cheol**  
**Gyeongsangnam-do (KR)**  
• **Yoo, Dong-Hee**  
**Seoul (KR)**

(74) Representative: **Viering, Jentschura & Partner**  
**Grillparzerstrasse 14**  
**81675 München (DE)**

(54) **Organic light emitting display device and method for manufacturing the same**

(57) Disclosed are an organic light emitting display device with improved yield and processing efficiency, which includes an interlayer (202) capable of being separated into a hydrophilic region (203) and a hydrophobic region on top of a hole injection layer (201) in an organic light emitting device and a plurality of layers including a light emitting layer (204) and which is fabricated without using a shadow mask, as well as a method for manufacturing the same. The manufacturing method includes preparing a substrate having a plurality of pixel regions defined in a matrix form, arranging an anode (200) in each of the pixel regions, forming a hole injection layer (201) on the anode (200) by the solution process, forming an interlayer (202) with hydrophobic properties on the hole injection layer (201) by a solution process, selectively UV irradiating the interlayer (202) to define a hydrophilic region (203) on the interlayer, forming a light emitting layer (204) on the interlayer (202) by the solution process, and arranging a cathode (206) on the substrate having the light emitting layer (204).

FIG. 3

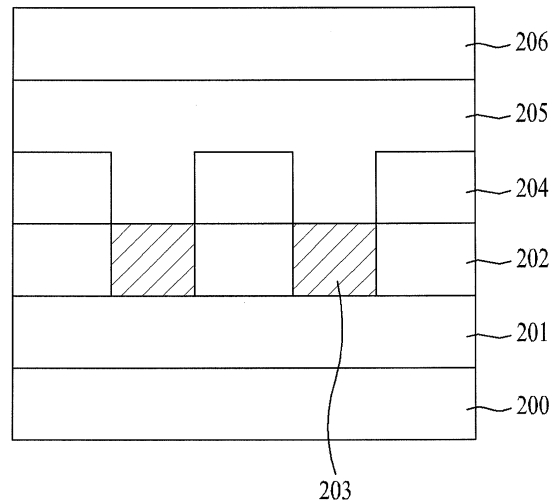

**EP 2 202 817 A1**

**Description**

**[0001]** This application claims the benefit of Korean Patent Applications No. P 10-2008-0133274, filed on December 24, 2008 and No. P 10-2009-0061771, filed on July 7, 2009, which are hereby incorporated by references as if fully set forth herein.

**BACKGROUND OF THE INVENTION****Field of the Invention**

**[0002]** The present invention relates to organic light emitting devices and, more particularly, to an organic light emitting display device with improved yield and processing efficiency, which includes an interlayer capable of being separated into a hydrophilic region and a hydrophobic region at a top of a hole injection layer in an organic light emitting device and a plurality of layers including a light emitting layer and which is fabricated without using a shadow mask, as well as a method for manufacturing the same.

**Discussion of the Related Art**

**[0003]** Recently, with progress towards an advanced information society, display applications for visual expression of electric information signals are rapidly growing. In response to such progress, a variety of thin, low weight, low power consumption and excellent performance flat display devices are currently being developed and rapidly replacing existing products such as cathode ray tubes (CRTs).

**[0004]** Examples of such a flat display device ("FDD") may include a liquid crystal display device (LCD), a plasma display panel device (PDP), a field emission display device (FED), an organic light emitting device (OLED), and the like.

**[0005]** Among these, an OLED useful for manufacturing a compact device and embodying a clear picture quality without need for an additional light source such as backlight is considered to have competitiveness in related applications.

**[0006]** In general, such an OLED requires an organic emitting layer and formation of the organic emitting layer is conducted by deposition using a shadow mask.

**[0007]** A conventional method for fabrication of an OLED will be described in detail by the following description with reference to the accompanying drawings.

**[0008]** FIG. 1 is a perspective view illustrating a general shadow mask and a process for deposition of a light emitting layer using the same.

**[0009]** As illustrated in FIG. 1, a commonly used shadow mask comprises a flat base 1 having at least one slit 2 extended in one direction at a certain width.

**[0010]** A vaporized emission material is exhausted as a gas through the slit 2 and is in turn deposited on a substrate 10 to form a light emitting layer 5.

**[0011]** FIG. 2 depicts a cross-section of the commonly used shadow mask with some problems thereof.

**[0012]** As illustrated in FIG. 2, the shadow mask 1 is positioned below the substrate 10 and the substrate 10 is placed such that the mask 1 is opposite to a face of the substrate on which a light emitting layer 5 is formed. In this case, vaporized gas is fed from a bottom of the mask 1 through slits 2 so as to form the light emitting layer 5.

**[0013]** However, if the shadow mask is used for a process for manufacturing a large-scale organic light emitting display device as shown in FIG. 2, a heavy weight of the shadow mask may cause deflection. Accordingly, the shadow mask has difficulty in repetitive use and may cause failure in forming a pattern on an organic emitting layer. For instance, use of the base 1 has problems in that the base may be bent or deformed, a cleaning agent ingredient may remain after rinsing, damage may occur at a boundary of the slit 2 during formation of the shadow mask 1, and/or alignment error may be encountered. Optionally, particles 1a generated during deposition may cause failure during a following deposition.

**[0014]** In order to solve the above problems, a novel alternative to conventional shadow masks is required. Especially, there is a strong requirement for development of a new deposition process in order to replace use of a shadow mask in an apparatus for fabrication of a large-scale organic light emitting display device, which causes deflection of the center portion of the shadow mask due to a weight thereof.

**[0015]** A conventional process for fabrication of an organic light emitting display device commonly used in the art entails the following problems.

**[0016]** A process for fabrication of a large-scale organic light emitting display device has difficulties in manufacturing a product caused by a weight of a shadow mask and may cause pattern failure due to deflection of the shadow mask.

**[0017]** With regard to manufacturing of a large-scale organic light emitting display device, a new process for formation of an organic semiconductor layer including a light emitting layer is required.

**[0018]** In addition, for general evaporation deposition using a shadow mask, raw material consumption is high. Therefore, investigation into a process change has been proposed in order to increase raw material utilization efficiency.

**SUMMARY OF THE INVENTION**

5 [0019] Accordingly, the present invention is directed to solving the problems described above, and an object of the present invention is to provide an organic light emitting display device with improved yield and processing efficiency, which includes an interlayer capable of being separated into a hydrophilic region and a hydrophobic region on top of a hole injection layer in an OLED and a plurality of layers including a light emitting layer and which is fabricated without using a shadow mask, as well as a method for manufacturing the same.

10 [0020] To achieve this object and other advantages and in accordance with the purpose of the invention, there is provided a method for manufacturing an organic light emitting display device, including: preparing a substrate having a plurality of pixel regions defined in a matrix form; arranging an anode in each of the pixel regions; forming a hole injection layer on the anode by the solution process; forming an interlayer with hydrophobic properties on the hole injection layer by the solution process; selectively UV irradiating the interlayer to define a hydrophilic region on the interlayer; forming a light emitting layer on the interlayer by the solution process; and arranging a cathode on the substrate having the light emitting layer.

15 [0021] More particularly, a method for manufacturing an organic light emitting display device according to an exemplary embodiment of the present invention may include: preparing a substrate having a plurality of pixel regions defined in a matrix form; arranging an anode in each of the pixel regions; forming a hole injection layer on the anode by the solution process; forming an interlayer with a water contact angle of 70° or more and hydrophobic properties on the hole injection layer by the solution process; selectively UV irradiating the interlayer to enable hydrophilic treatment of the interlayer so as to have a water contact angle of less than 70° at the UV irradiated portion of the interlayer; forming a light emitting layer on the interlayer except for the UV irradiated portion; and arranging a cathode on the substrate having the light emitting layer.

20 [0022] The formation of the interlayer may include dipping the substrate having the anode and the hole injection layer into an interlayer material or, otherwise, applying the interlayer material to the top of the substrate having the anode and the hole injection layer by at least one selected from a group consisting of spin coating, roll printing, slit coating, nozzle coating and ink-jetting.

25 [0023] The formation of the light emitting layer may include dipping the substrate having the anode, the hole injection layer and the interlayer into a light emitting material or, otherwise, applying the light emitting material to the top of the substrate having the anode, the hole injection layer and the interlayer by at least one selected from a group consisting of spin coating, roll printing, slit coating, nozzle coating and ink-jetting.

30 [0024] The foregoing method may further include, after formation of the light emitting layer, forming an electron transport layer on the top of the light emitting layer by at least one selected from a group consisting of dipping, spin coating, nozzle coating, slit coating, roll printing, ink-jetting and evaporation deposition.

35 [0025] The interlayer formed above may be composed of a material with UV absorption or photolysis performance. The interlayer may contain an organic substance having at least one bond selected from C-C, C=N, C=C, Si-O, C-O and C=O. The interlayer may contain at least one selected from a group consisting of imide, amine, silane, carbonate, ester, acetate, sulfonate, nitrate, ketone, fluorine, oxetane and epoxy. Preferably, the interlayer may include triphenylamine.

40 [0026] The UV irradiation is performed at a wavelength of 150 to 260nm under a pressure of  $1 \times 10^{-5}$  torr to 800 torr.

45 [0027] In order to achieve the same object described above, a method for manufacturing an organic light emitting display device according to another exemplary embodiment of the present invention may include: preparing a substrate having a plurality of pixel regions defined in a matrix form; arranging an anode in each of the pixel regions; forming a hole injection layer on the anode by the solution process; forming an interlayer with hydrophobic properties on the hole injection layer by the solution process; selectively UV irradiating the interlayer to pattern the same; forming a light emitting layer on the patterned interlayer by the solution process; and arranging a cathode on the substrate having the light emitting layer.

50 [0028] The fabricated organic light emitting display device may include: a substrate having a plurality of pixel regions defined in a matrix form; an anode arranged in each of the pixel regions; a hole injection layer formed on the anode; an interlayer with hydrophobic properties formed on the hole injection layer by the solution process, wherein the interlayer has substantially the same interface properties at a face coming into contact with the hole injection layer as well as hydrophobic properties at the top thereof, and comprises a hydrophobic region and a hydrophilic region separated therein by UV irradiation; a light emitting layer and an electron transport layer formed on the hydrophobic interlayer; and a cathode arranged on the electron transport layer.

55 [0029] The foregoing organic light emitting display device and the method for manufacturing the same according to the present invention have various advantages as follows.

[0030] After preparing a hole injection layer on an anode and then an interlayer, a following layer may be formed on top of the hole injection layer by the solution process. Here, a surface of the interlayer has hydrophobic properties with a water contact angle of 70° or more. The interlayer is composed of a material with UV activity and, after selective UV

irradiation, a hydrophobic light emitting layer is formed on the interlayer except for a portion under hydrophilic treatment to control the water contact angle to less than 70°, so as to precisely align the light emitting layer in a patterned region of the interlayer. Briefly, the interlayer is hydrophobic when formed by a solution process and may have a hydrophilic region selectively defined by UV irradiation. Therefore, even if a solvent used for forming a top layer is hydrophobic, the solvent comes into contact with a hydrophobic part of the interlayer so as to enable precise alignment of the solvent in a patterned region of the interlayer.

**[0031]** Also, the interlayer is composed of the material with UV activity. After UV irradiation of the interlayer, the irradiated layer is aligned on a surface-treated region so as to enable precise alignment of the top layer (such as a light emitting layer and an electron transport layer) in a desired position.

**[0032]** For the fabricated organic light emitting display device, a layer (such as the light emitting layer together with upper and lower layers thereof) may be formed above the hole injection layer by the solution process and, therefore, a shadow mask typically used in the art may be omitted. As a result, process failure possibly caused by the shadow mask may be effectively prevented, thus enhancing productivity and yield. The present invention may enable film treatment and patterning using film characteristics and may be favorably applied to manufacturing of a large-scale organic light emitting display device.

**[0033]** Placing an interlayer on top of a hole injection layer, a solution process may be performed at an interface of the hole injection layer and an upper layer thereon without difficulty. The hole injection layer may be formed using a conductive polymer material so as to enhance luminance relative to current and extend a lifespan of a display device.

**[0034]** It is to be understood that both the foregoing general description and the following detailed description of the present invention are exemplary and explanatory and are intended to concretely describe the invention as claimed.

### **BRIEF DESCRIPTION OF THE DRAWINGS**

**[0035]** The accompanying drawings, which are included to provide a further understanding of the invention and are incorporated in and constitute a part of this application, illustrate embodiment(s) of the invention and together with the description serve to explain the principle of the invention. In the drawings:

**[0036]** FIG. 1 is a perspective view illustrating a conventional shadow mask and a process for deposition of a light emitting layer using the shadow mask;

**[0037]** FIG. 2 is a cross-sectional view illustrating a conventional shadow mask with some problems thereof;

**[0038]** FIG. 3 is a cross-sectional view illustrating an organic light emitting display device of the present invention;

**[0039]** FIGS. 4A to 4G are cross-sectional views illustrating a process for fabrication of an organic light emitting display device according to an exemplary embodiment of the present invention;

**[0040]** FIGS. 5A to 5C depict water contact angles of solutions with different properties; and

**[0041]** FIGS. 6A to 6G are cross-sectional views illustrating a process for fabrication of an organic light emitting display device according to another exemplary embodiment of the present invention.

### **DETAILED DESCRIPTION OF THE INVENTION**

**[0042]** Hereinafter, an organic light emitting display device and a method for fabricating the same according to the present invention will be described in detail from the following description with reference to exemplary embodiments, taken in conjunction with the accompanying drawings.

**[0043]** FIG. 3 is a cross-sectional view illustrating an organic light emitting display device of the present invention.

**[0044]** As illustrated in FIG. 3, the inventive organic light emitting display device comprises: a substrate having a plurality of pixel regions defined in a matrix form; an anode 200 arranged in each of the pixel regions; a hole injection layer 201 placed on the anode 200; an interlayer 202 having a hydrophilic region 203 and a hydrophobic region; a light emitting layer 204 formed in the hydrophobic region of the interlayer 202 and an electron transport layer 205 placed on the substrate having the light emitting layer 204; and a cathode 206 arranged on the electron transport layer 205.

**[0045]** Although the interlayer 202 initially formed by a solution process has hydrophobic properties, selectively UV irradiating the same may modify the irradiated part 203 to be hydrophilic or remove the irradiated part, thereby enabling selective formation of plural films by the solution process.

**[0046]** When the hole injection layer 201 contains a super-hydrophilic conductive polymer such as polystyrene-sulphonate-doped polyethylene-dioxythiophene (PEDOT:PSS), the interlayer 202 having super-hydrophilic properties may be provided in order to eliminate difficulty in directly applying a hydrophobic solvent to the hole injection layer 201.

**[0047]** Briefly, the interlayer 202 primarily comprises the hydrophilic region 203 formed by UV treatment as well as the hydrophobic region. Here, the light emitting layer 204 on top of the interlayer 202 may be selectively formed in the hydrophobic region, which was not subjected to selective UV irradiation, when a solution is applied to the interlayer 202 by the solution process.

**[0048]** In this case, a top of the interlayer 202, especially, a surface thereof on which the light emitting layer 204 is

formed may have hydrophobic properties with a water contact angle of 70° or more.

**[0049]** As for raw materials, the interlayer 202 may comprise a material with UV absorption or photolysis performance. Alternatively, the interlayer 202 may have modified physical properties such as hydrophilic properties without being patterned by UV irradiation.

5 **[0050]** The interlayer 202 may contain an organic material having at least one bond selected from C-C, C=N, C=C, Si-O, CO, C=O, etc. For instance, the interlayer may have at least one functional group selected from a group consisting of imide, amine, silane, carbonate, ester, acetate, sulfonate, nitrate, ketone, fluorine, oxetane, epoxy, and the like. An example of the organic material having an amine group is triphenylamine.

10 **[0051]** Hereinafter, examples of an organic ingredient contained in the interlayer 202 will be described in detail.

**[0052]**

Formula 1

15

20

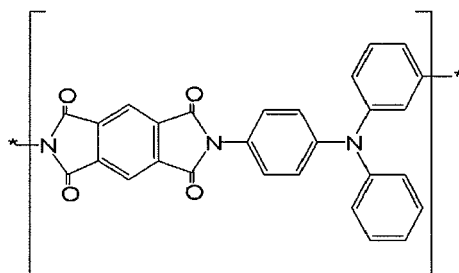

25

**[0053]**

Formula 2

30

35

40

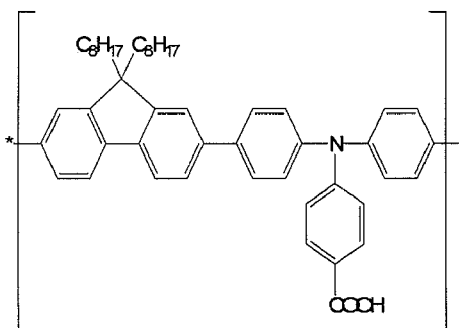

45

**[0054]**

50

55

Formula 3

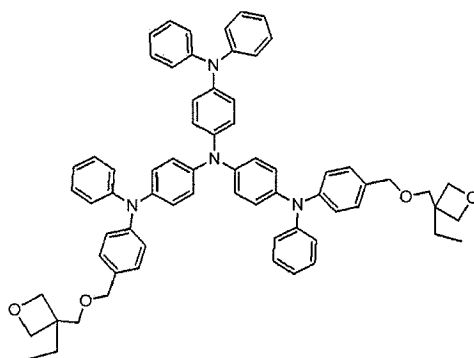

**[0055]** Here, all the interlayer 202, the light emitting layer 204 and the electron transport layer 205 may be fabricated by a solution process and the solution process may include, for example: dipping a substrate (not shown) having the anode 200 and the hole injection layer 201 into a desired solvent for a material used for the foregoing film or layer; applying the foregoing solvent over the top of the substrate having the anode 200 and the hole injection layer 201 by spin coating, roll printing, nozzle coating to continuously spray the solvent over the substrate, slit coating using a flat slit so as to coat a part corresponding to the slit, ink-jetting the solvent in dot units, and so forth.

**[0056]** As illustrated above, all of the hole injection layer 201, the interlayer 202, the light emitting layer 204 and the electron transport layer 205 except for the cathode 206 may be fabricated by the foregoing solution process.

**[0057]** The interlayer 202 may be selectively separated into the hydrophilic region 203 and the hydrophobic region by UV irradiation and, after the irradiation, may have both the hydrophilic region and the hydrophobic region. Accordingly, if a UV irradiated portion in the hydrophobic region of the interlayer 202 is modified to have hydrophilic properties, the remaining hydrophobic groups meet with other hydrophobic groups of a solvent for each layer formed by the solution process so as to enable coating of the layer.

**[0058]** FIGS. 4A to 4G are cross-sectional views illustrating a process for fabrication of an organic light emitting display device according to an exemplary embodiment of the present invention, while FIGS. 5A to 5C depict water contact angles of solutions with different properties.

**[0059]** The following description will be given of a method for manufacturing an organic light emitting display device according to another exemplary embodiment of the present invention.

**[0060]** First, a substrate (not shown) having a plurality of pixel regions defined in a matrix form is prepared. For each of the pixel regions on the substrate, a thin film transistor is provided. Although not illustrated, the thin film transistor may comprise a gate electrode arranged at a desired site on the substrate, a semiconductor layer formed on top of the gate electrode by interposing a gate insulation film therebetween, and a source/drain electrode arranged at both ends of the semiconductor layer.

**[0061]** As shown in FIG. 4A, an anode 200 is formed in each pixel region. The anode 200 may be connected to the thin film transistor.

**[0062]** Next, a hole injection layer 201 is placed on the anode 200. As described above, the hole injection layer 201 may comprise a material with moderate acidity to protect the thin film transistor from damage, and may be composed of PEDOT:PSS with improved conductive properties. In this case, the hole injection layer 201 is formed by coating the anode with a solution including the foregoing material at 1,000 to 3,000 rpm and baking the coating at not more than 200°C for 5 to 30 minutes. In order to improve coating ability and to control coating thickness, water or any other organic solvent such as alcohol, glycol, etc. may be added during coating. Here, the material of the hole injection layer 201 is not particularly restricted to PEDOT:PSS and may also include any materials subjected to the solution process.

**[0063]** Following this, as shown in FIG. 4B, an interlayer 202 having hydrophobic surface characteristics with a water contact angle of 70° or more is formed on top of the hole injection layer 201. This interlayer 202 may be composed of a material exhibiting hydrophobicity at a surface coming into contact with a following layer to be formed.

**[0064]** As illustrated in FIGS. 5A to 5C, the water contact angle means an angle between a normal line passing the surface of a solution and a test plate, when the solution falls on the test plate.

**[0065]** FIG. 5A shows a strong hydrophilic material to illustrate that the foregoing solution 451 sufficiently spreads on the test plate. That is, it is found that a water contact angle  $\Theta_1$  of the material is very small such as not more than 20°.

**[0066]** FIG. 5B shows a solution 452 with a water contact angle  $\Theta_2$  corresponding to a boundary between hydrophilic and hydrophobic properties, approximately 60° or less.

**[0067]** FIG. 5C shows a super-hydrophobic solution 453, wherein a water contact angle  $\Theta_3$  of the solution is 90° or

more. Such a solution contains a material to capture hydrophobic ingredients on a surface of the super-hydrophobic solution 453 when a hydrophobic material is applied to the top of the solution, while applying a hydrophilic material to the top of the solution pushes hydrophilic ingredients out of the solution so as to substantially eliminate the hydrophilic ingredients from the super-hydrophobic solution 453.

5 [0068] Briefly, decreasing the water contact angle of the solution may increase hydrophilic properties of the solution while increasing the water contact angle may tend to increase hydrophobic properties of the solution.

[0069] With the water contact angle of approximately not less than 70°, the material is considered to exhibit hydrophobic tendencies. The interlayer 202 may comprise any one selected from hydrophobic materials with a water contact angle of not less than 70°, as shown in FIGS. 5B and 5C.

10 [0070] Formation of the interlayer 202 may be performed by the solution process, for example, dipping a substrate (not shown) having the anode 200 and the hole injection layer 201 into an interlayer material or, otherwise, applying the interlayer material to the top of the substrate having the anode 200 and the hole injection layer 201 by at least one selected from a group consisting of spin coating, roll printing, nozzle coating, slit coating and ink-jetting.

15 [0071] A functional group contained in the interlayer material may have at least one bond selected from a group consisting of C-C, C=N, C=C, Si-O, C-O and C=O. For example, the interlayer may contain at least one selected from a group consisting of imide, amine, silane, carbonate, ester, acetate, sulfonate, nitrate, ketone, fluorine, oxetane and epoxy. More particularly, the interlayer comprises triphenylamine.

[0072] As shown in FIG. 4C, the interlayer 202 is subjected to UV irradiation using a mask 300 (having a transmission part 301 and a shading part 302).

20 [0073] UV irradiating a material of the interlayer 202 as shown in FIG. 4D, an irradiated portion of the interlayer has a water contact angle of not more than 70° which in turn changes the hydrophobic properties of the irradiated portion into hydrophilic properties, thus forming a transformation part 203 in the interlayer 202.

[0074] Accordingly, the transformation part 203 modified after UV irradiation may exhibit hydrophilic properties while the other part of the interlayer remains hydrophobic. Consequently, when a following film is formed above the interlayer 202 having the transformation part 203, selective patterning may be carried out depending on whether the formed film is hydrophilic or hydrophobic.

25 [0075] UV irradiation of the interlayer 202 may be conducted at a wavelength of 100 to 400nm, preferably, 150 to 260nm. Further, a pressure required for UV irradiation may range  $1 \times 10^{-5}$  torr to 800 torr.

30 [0076] As illustrated in FIG. 4E, the interlayer 202 having the transformation part 203 is subjected to a solution process in order to selectively form a light emitting layer 204 at a site retaining hydrophobic properties due to not being subjected to UV irradiation. Such selective formation of the light emitting layer 204 does not require specific external influences or conditions but is attained by the interlayer 202 having the transformation part 203 modified into hydrophilic conditions. Accordingly, the light emitting layer 204 is formed by differences in physical properties of different regions of the interlayer 202. That is, the solution sprayed over the interlayer 202 may remain on the interlayer 202 selectively excluding the transformation part 203 thereof.

35 [0077] As illustrated in FIG. 4F, an electron transport layer 205 is placed on the substrate having the light emitting layer 204.

[0078] The light emitting layer 204 and the electron transport layer 205 may be provided as a combined film wherein the electron transport layer 205 may comprise hydrophobic ingredients.

40 [0079] Each of the hole injection layer 201, the interlayer 202, the light emitting layer 204 and the electron transport layer 205 may be formed using the solution process, especially, by dipping, spin coating, nozzle coating, roll printing, slit coating and/or ink-jetting as described above.

[0080] Alternatively, the electron transport layer 205 capable of being formed throughout the substrate may also be provided by evaporation deposition.

45 [0081] Subsequently, as illustrated in FIG. 4G, a cathode 206 is formed on top of the electron transport layer 205.

[0082] The hole injection layer 201, the interlayer 202, the light emitting layer 204 and the electron transport layer 205 may be separately prepared by a solution process, or a combination of two or more thereof may be formed. In consideration of convenience, the interlayer 202 requires UV radiation for region segmentation and, therefore, the foregoing solution process may be separately performed before and after formation of the interlayer 202.

50 [0083] FIGS. 6A to 6G are cross-sectional views illustrating a process for fabrication of an organic light emitting display device according to another exemplary embodiment of the present invention.

[0084] A method for manufacturing an organic light emitting display device according to another exemplary embodiment of the present invention may be progressed by the following steps.

55 [0085] First, a substrate (not shown) having a plurality of pixel regions defined in a matrix form is prepared. For each of the pixel regions on the substrate, a thin film transistor is provided. Although not illustrated, the thin film transistor may comprise a gate electrode arranged at a desired site on the substrate, a semiconductor layer formed on top of the gate electrode by interposing a gate insulation film therebetween, and a source/drain electrode arranged at both ends of the semiconductor layer.

[0086] As shown in FIG. 6A, an anode 400 is formed in each pixel region such that the anode is connected to the thin film transistor.

[0087] Next, a hole injection layer 401 is placed on the anode 400. As described above, the hole injection layer 401 may comprise a material with moderate acidity to protect the thin film transistor from damage, and may be composed of PEDOT:PSS with improved conductive properties. In this case, the hole injection layer 401 is formed by coating the anode with a solution including the foregoing material at 1,000 to 3,000 rpm and baking the coating at not more than 200°C for 5 to 30 minutes. In order to improve coating ability and to control coating thickness, water or any other organic solvent such as alcohol, glycol, etc. may be added during coating. Here, the material of the hole injection layer 401 is not particularly restricted to PEDOT:PSS and may also include any materials having characteristics of a hydrophilic conductive polymer material.

[0088] Following this, as shown in FIG. 6B, an interlayer 402 having hydrophobic surface characteristics with a water contact angle of 70° or more is formed on top of the hole injection layer 401. This interlayer 402 may be composed of a material exhibiting hydrophobicity at a surface coming into contact with a following layer to be formed.

[0089] Formation of the interlayer 402 may be performed by the solution process, for example, dipping a substrate (not shown) having the anode 400 and the hole injection layer 401 into an interlayer material, or applying the interlayer material to the top of the substrate having the anode 400 and the hole injection layer 401 by at least one selected from a group consisting of spin coating, roll printing, slit coating, nozzle coating and ink-jetting.

[0090] After UV irradiation, the foregoing interlayer material is subjected to patterning and may comprise a material exhibiting UV absorption or photolysis performance. For instance, if the interlayer material has UV photolysis performance, an UV irradiated part will be duly eliminated after UV irradiation. In contrast, when the interlayer material has UV absorption and cross-linkable ability, only a UV irradiated part remains after UV irradiation.

[0091] Such an interlayer 402 may entirely cover the hole injection layer 401 with excellent adhesiveness during coating regardless of hydrophilic/hydrophobic properties of the hole injection layer. Subsequently, hydrophobic groups present in the remaining pattern, which was formed after UV irradiation, may support adhesion of ingredients (hydrophobic groups) coated by the solution process during formation of a following light emitting layer.

[0092] A functional group contained in a material for the interlayer 402 may have at least one bond selected from a group consisting of C-C, C=N, C=C, Si-O, C-O and C=O. For instance, the interlayer may contain at least one selected from a group consisting of imide, amine, silane, carbonate, ester, acetate, sulfonate, nitrate, ketone, fluorine, oxetane and epoxy. More particularly, the interlayer may contain triphenylamine.

[0093] The foregoing material for the interlayer may be a material having a cross-linkable group (exhibiting UV absorption) and/or a functional group with UV photolysis performance.

[0094] As illustrated in FIG. 6C, the interlayer 402 is subjected to UV irradiation using a mask 300 (having a transmission part 301 and a shading part 302) and patterning, so as to produce an interlayer pattern 402a, as illustrated in FIG. 6D. The interlayer pattern 402a is obtained by the patterning process to leave behind a hydrophobic region. On the other hand, a part activated by UV irradiation is eliminated while the hydrophobic interlayer pattern 402a may yet remain on the top of the hole injection layer, as illustrated in FIG. 6D. UV irradiation of the interlayer 402 may be conducted at a wavelength of 100 to 400nm, preferably, 150 to 260nm. A pressure of UV irradiation may range from  $1 \times 10^{-5}$  torr to 800 torr. In the drawings, the interlayer 402 is an illustrative example of materials with photolysis performance. For a material with absorptive performance, using a mask 300 in a reverse form relative to that illustrated in FIG. 6C may produce the interlayer pattern 402a illustrated in FIG. 6D.

[0095] As illustrated in FIG. 6E, a light emitting layer 404 is formed on the interlayer pattern 402a remaining as the hydrophobic region by the solution process. Formation of the light emitting layer 404 does not require specific external influences or conditions but is provided on the hydrophobic interposing pattern 402a patterned by UV irradiation. Here, the light emitting layer 404 including an organic emitting material with high hydrophobicity is formed on the top of the hydrophobic interlayer pattern 402a by differences in physical properties of an area at which the above hydrophobic interlayer pattern 402a is present and the other area without the pattern. That is, since the hole injection layer 401 exposed between plural interlayer patterns 402a is hydrophilic, a solution sprayed throughout the interlayer including the foregoing film patterns 402a may selectively remain on the film patterns 402a with hydrophobic properties.

[0096] The solution process used for forming the light emitting layer 404 may include dipping the substrate (not shown) having the anode 400, the hole injection layer 401 and the interlayer pattern 402a into a light emitting material or, otherwise, applying the light emitting material to the top of the substrate having the anode 400, the hole injection layer 401 and the interlayer pattern 402a by spin coating, nozzle coating, roll printing or ink-jetting.

[0097] Next, as shown in FIG. 6F, an electron transport layer 405 is placed on the substrate (not shown) having the light emitting layer 404.

[0098] The light emitting layer 404 may be combined with a hole transport layer (not shown) and the foregoing electron transport layer 405 to form a single laminate layer.

[0099] Each of the interlayer 402, the hole transport layer, the light emitting layer 404 and the electron transport layer 405 described above may be formed using the solution process, especially, by dipping, spin coating, nozzle coating,

roll printing, slit coating and/or ink-jetting described above. Here, the interlayer 402, the light emitting layer 404 and the electron transport layer 405 may be separately formed or, otherwise, may form a region defined by a single patterning. [0100] Alternatively, the electron transport layer 405 capable of being formed throughout the substrate may also be provided by evaporation deposition.

[0101] Subsequently, as illustrated in FIG. 6G, a cathode 406 is formed on top of the electron transport layer 405.

[0102] Hereinafter, material properties of the interlayer used in an organic light emitting display device according to the present invention will be more concretely discussed.

[0103] A top of the interlayer formed on the hole injection layer is hydrophobic. If a film formed thereon is hydrophobic, a part of the formed film is subjected to UV irradiation to modify the irradiated portion only, thereby enabling selective formation of a light emitting layer only on the hydrophobic area without using an alternative mask. The top of the formed interlayer is hydrophobic and in turn may be modified to be hydrophilic by UV irradiation or may have UV absorption or photolysis performance, so that only the irradiated part remains or is eliminated.

[0104] As disclosed in the above description, the method for manufacturing an organic light emitting display device of the present invention may include: forming a hole injection layer 201 or 401 on an anode 200 or 400; forming an interlayer 202 or 402 thereon; UV irradiating the interlayer 202 or 402 to define a hydrophilic region 203 on the interlayer 202 or, otherwise, removing a UV irradiated portion to form an interlayer pattern 402a to selectively expose a bottom hole injection layer 401; separating the pattern into a hydrophilic region and a hydrophobic region; and selectively forming a light emitting layer 204 or 404 in only the hydrophobic region of the interlayer or the interlayer pattern 202 or 402a. Briefly, as for formation of a film such as the light emitting layer 204 or 404, even when a desired solvent for the film is hydrophobic, the solvent comes into contact with a hydrophobic-treated face of the interlayer which in turn enables precise alignment of the solvent in a patterned region of the interlayer.

[0105] The interlayer 202 or the interlayer pattern 402a may be fabricated using a UV active material, for example, one that is cross-linkable or degradable at an irradiated site or has specific physical properties such as hydrophobicity modified into hydrophilicity. After UV irradiation of the interlayer, the irradiated layer is aligned on a surface treated region so as to enable precise alignment of the top layer (the light emitting layer 204 or 404) in a desired position.

[0106] The above description will be more apparent from the following test results in relation to UV irradiation of an interlayer comprising each of the foregoing materials represented by Formulae 1 to 3.

[0107] First, a pixel accuracy of each interlayer formed using the material represented by Formula 1 was examined. It was found that the UV treated interlayer exhibited 20% higher pixel accuracy, compared to the interlayer without UV treatment. Also, all of the interlayers subjected to UV treatment have a pixel accuracy of not less than 95% and essentially no alignment error was detected.

[0108]

TABLE 1

Number of treatment	Pixel accuracy of UV treated interlayer (%)	Pixel accuracy at UV un-treated interlayer (%)
1	95	72
2	96	75
3	98	74

[0109] A pixel accuracy of each interlayer formed using the material represented by Formula 2 was examined. It was found that the UV treated interlayer exhibited 20% higher pixel accuracy, compared to the interlayer without UV treatment. Also, all of the interlayers subjected to UV treatment have a pixel accuracy of not less than 94% and essentially no alignment error was detected.

[0110]

TABLE 2

Number of treatment	Pixel accuracy of UV treated interlayer (%)	Pixel accuracy at UV un-treated interlayer (%)
1	94	74
2	95	72
3	97	74

[0111] A pixel accuracy of each interlayer formed using the material represented by Formula 3 was examined. Similarly to the above results, it was found that the UV treated interlayer exhibited 18% higher pixel accuracy, compared to the

interlayer without UV treatment. Also, all of the interlayers subjected to UV treatment have a pixel accuracy of not less than 94% and essentially no alignment error was detected.

**[0112]**

TABLE 3

Number of treatment	Pixel accuracy of UV treated interlayer (%)	Pixel accuracy at UV un-treated interlayer (%)
1	96	78
2	97	74
3	94	76

**[0113]** For the fabricated organic light emitting display device, a layer (such as an interlayer, a light emitting layer, an electron transport layer, etc.) may be formed above the hole injection layer by the solution process and, therefore, a shadow mask typically used in the art may be omitted. As a result, process failure possibly caused by the shadow mask may be effectively prevented, thus enhancing productivity and yield. The present invention may enable film treatment and patterning using film characteristics and may be favorably applied to manufacturing of a large-scale organic light emitting display device.

**[0114]** Placing an interlayer on top of a hole injection layer, a solution process may be performed at an interface of the hole injection layer and an upper layer thereon without difficulty. The hole injection layer may be formed using a conductive polymer material so as to enhance luminance relative to current and extend a lifespan of a display device.

**[0115]** Although technical constructions and other features of the present invention have been described, it will be apparent to those skilled in the art that the present invention is not limited to the exemplary embodiments and accompanying drawings described above but may cover substitutions, variations and/or modifications thereof without departing from the scope of the invention defined in the appended claims.

## Claims

1. A method for manufacturing an organic light emitting display device, comprising:

preparing a substrate having a plurality of pixel regions defined in a matrix form;  
 arranging an anode in each of the pixel regions;  
 forming a hole injection layer on the anode by a solution process;  
 forming an interlayer with hydrophobic properties on the hole injection layer by the solution process;  
 selectively UV irradiating the interlayer to define a hydrophilic region on the interlayer;  
 forming a light emitting layer on the interlayer by the solution process; and  
 arranging a cathode on the substrate having the light emitting layer.

2. A method for manufacturing an organic light emitting display device, comprising:

preparing a substrate having a plurality of pixel regions defined in a matrix form;  
 arranging an anode in each of the pixel regions;  
 forming a hole injection layer on the anode by a solution process;  
 forming an interlayer with a water contact angle of 70° or more and hydrophobic properties on the hole injection layer by the solution process;  
 selectively UV irradiating the interlayer to enable hydrophilic treatment of the interlayer so as to have a water contact angle of less than 70° at the UV irradiated portion of the interlayer;  
 forming a light emitting layer on the interlayer except for the UV irradiated portion; and  
 arranging a cathode on the substrate having the light emitting layer.

3. The method according to claim 2, further comprising:

after formation of the light emitting layer, forming an electron transport layer on top of the light emitting layer by at least one selected from a group consisting of dipping, spin coating, nozzle coating, slit coating, roll printing, ink-jetting and evaporation deposition.

4. The method according to claim 2, wherein the UV irradiation is performed at a wavelength of 150 to 260nm.
5. The method according to claim 2, wherein a pressure of the UV irradiation ranges from  $1 \times 10^{-5}$  torr to 800 torr.
- 5 6. A method for manufacturing an organic light emitting display device, comprising:
- preparing a substrate having a plurality of pixel regions defined in a matrix form;  
arranging an anode in each of the pixel regions;  
forming a hole injection layer on the anode by a solution process;  
10 forming an interlayer with hydrophobic properties on the hole injection layer by the solution process;  
selectively UV irradiating the interlayer to pattern the same;  
forming a light emitting layer on the patterned interlayer by the solution process; and  
arranging a cathode on the substrate having the light emitting layer.
- 15 7. The method according to claim 2 or 6, wherein the formation of the interlayer comprises dipping the substrate having the anode and the hole injection layer into an interlayer material or, otherwise, applying the interlayer material to the top of the substrate having the anode and the hole injection layer by at least one selected from a group consisting of spin coating, roll printing, nozzle coating, slit coating and ink-jetting.
- 20 8. The method according to claim 2 or 6, wherein the formation of the light emitting layer comprises dipping the substrate having the anode, the hole injection layer and the interlayer into a light emitting material or, otherwise, applying the light emitting material to the top of the substrate having the anode, the hole injection layer and the interlayer by at least one selected from a group consisting of spin coating, roll printing, nozzle coating, slit coating and ink-jetting.
- 25 9. The method according to claim 6, further comprising:
- before or after formation of the light emitting layer, forming an electron transport layer on top of the light emitting layer by at least one selected from a group consisting of dipping, spin coating, nozzle coating, roll  
30 printing, slit coating and ink-jetting.
10. The method according to claim 2 or 6, wherein the interlayer is composed of a material exhibiting UV absorption or photolysis performance.
- 35 11. The method according to claim 2 or 6, wherein the interlayer contains an organic substance having at least one bond selected from C-C, C=N, C=C, Si-O, C-O and C=O.
12. The method according to claim 11, wherein the interlayer contains at least one selected from a group consisting of imide, amine, silane, carbonate, ester, acetate, sulfonate, nitrate, ketone, fluorine, oxetane and epoxy.
- 40 13. The method according to claim 12, wherein the interlayer contains triphenylamine.
14. The method according to claim 6, wherein the UV irradiation is performed at a wavelength of 150 to 260nm under a pressure of from  $1 \times 10^{-5}$  torr to 800 torr.
- 45 15. An organic light emitting display device, comprising:
- a substrate having a plurality of pixel regions defined in a matrix form;  
an anode arranged in each of the pixel regions;  
a hole injection layer formed on the anode;  
50 an interlayer with hydrophobic properties formed on the hole injection layer by a solution process, wherein the interlayer comprises a hydrophobic region and a hydrophilic region separated therein by UV irradiation;  
a light emitting layer and an electron transport layer formed on the hydrophobic interlayer; and  
a cathode arranged on the electron transport layer.
- 55

RELATED ART  
FIG. 1

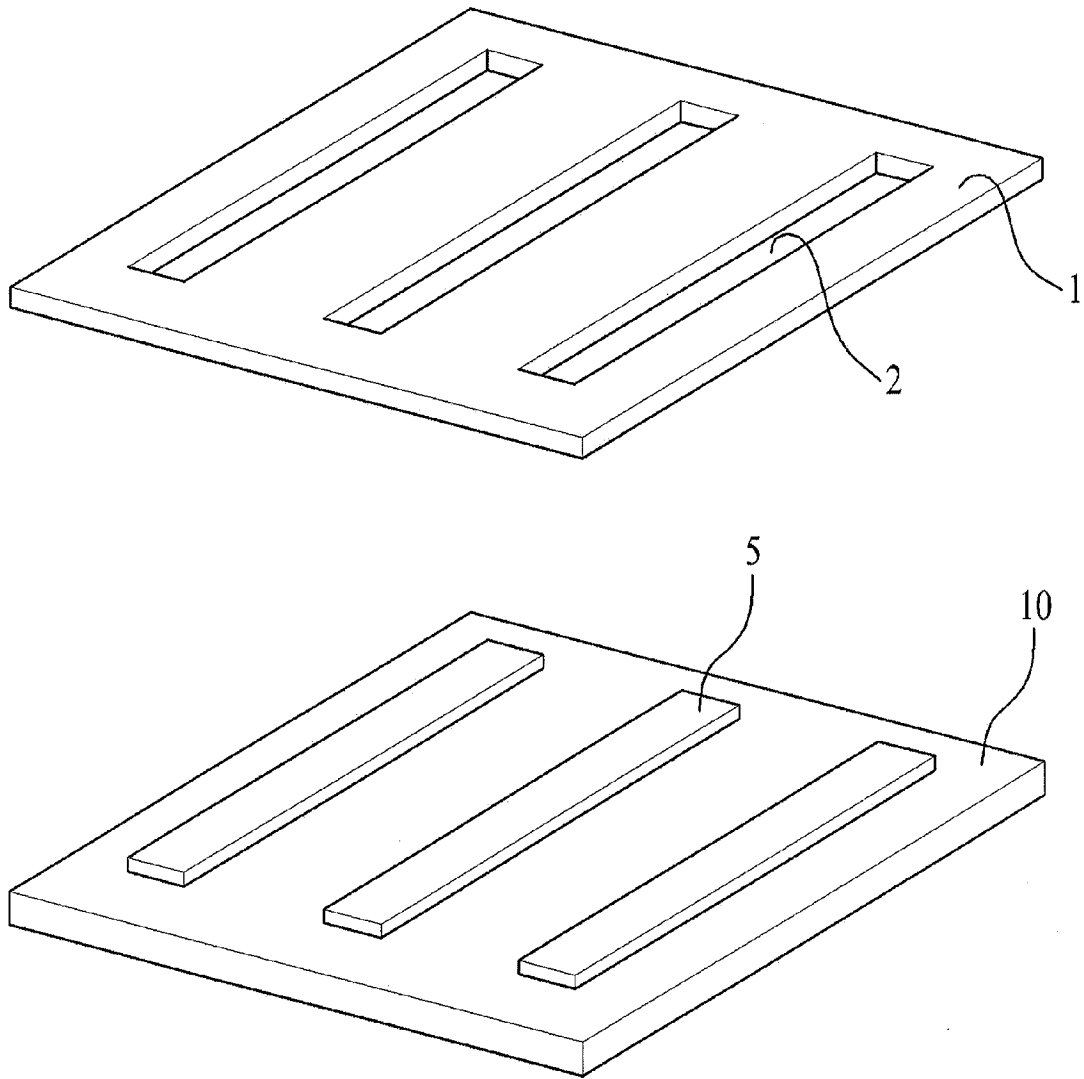

RELATED ART  
FIG. 2

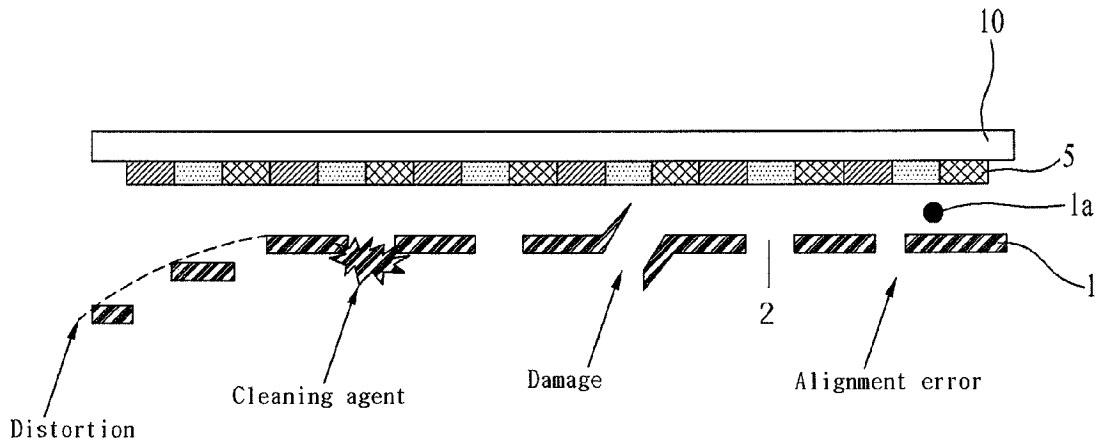

FIG. 3

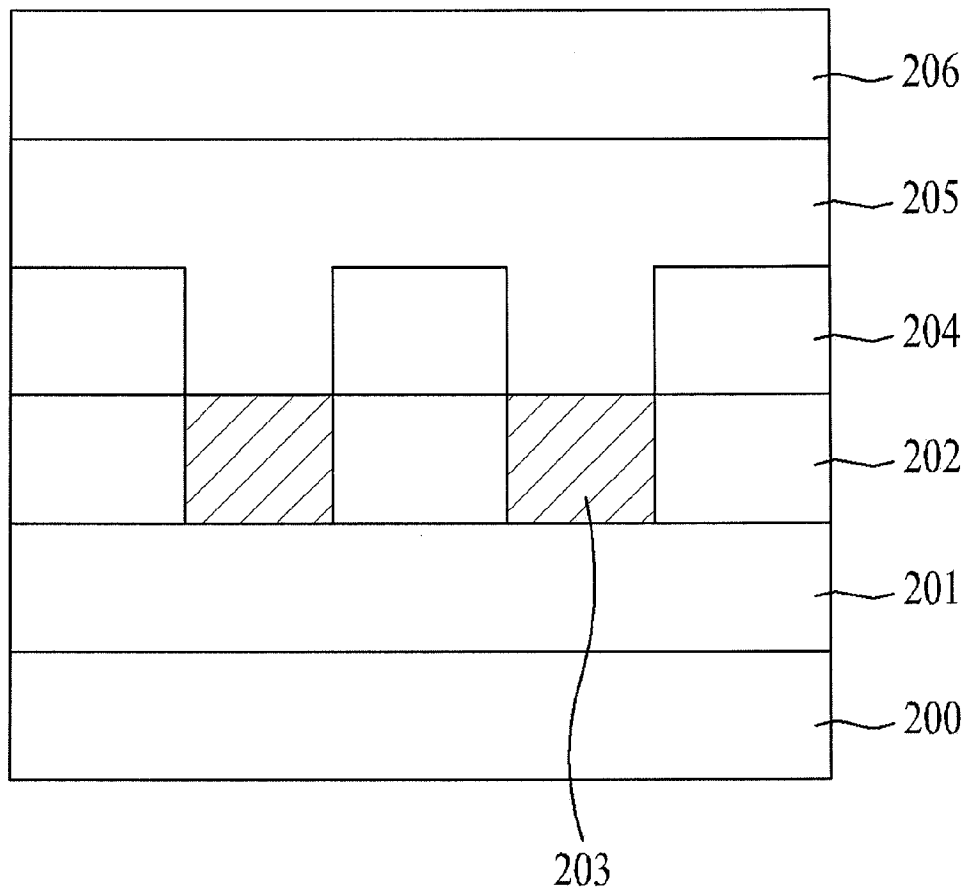

FIG. 4A

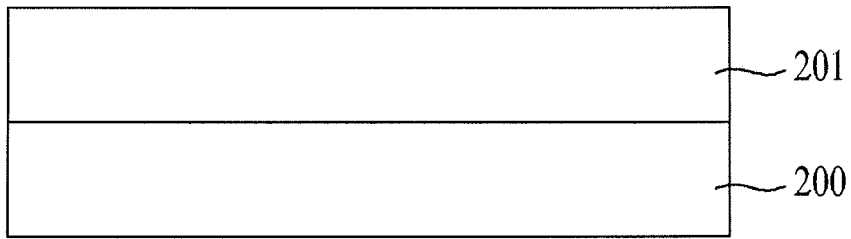

FIG. 4B

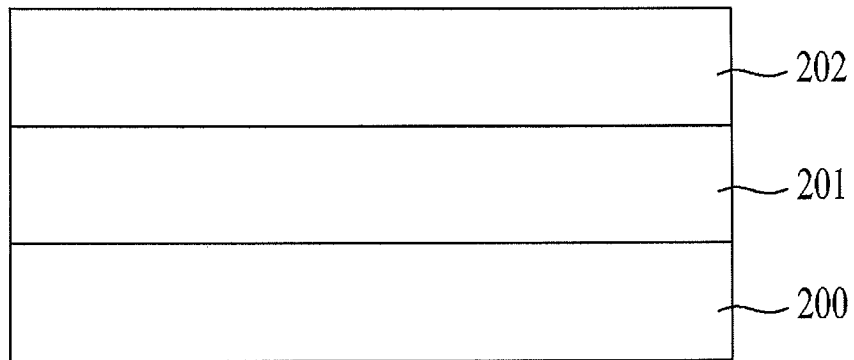

FIG. 4C

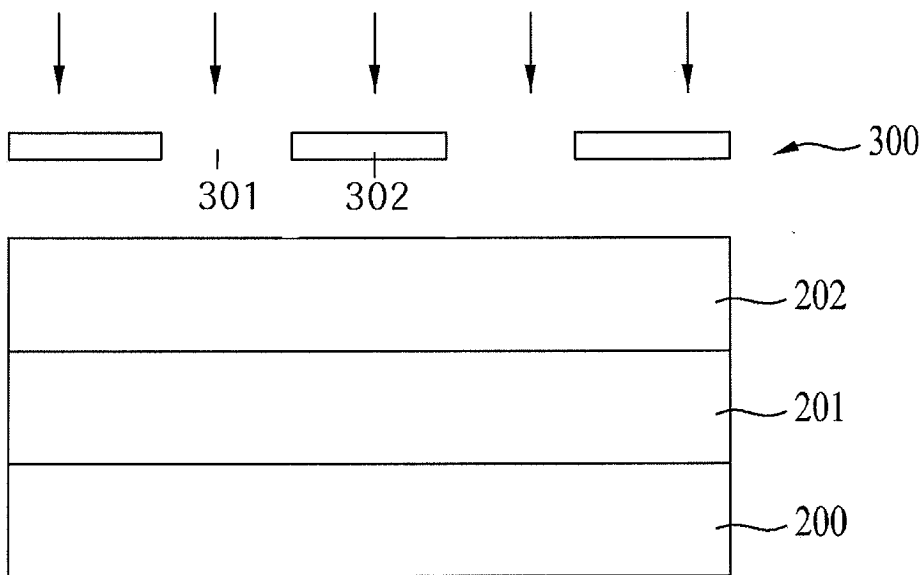

FIG. 4D

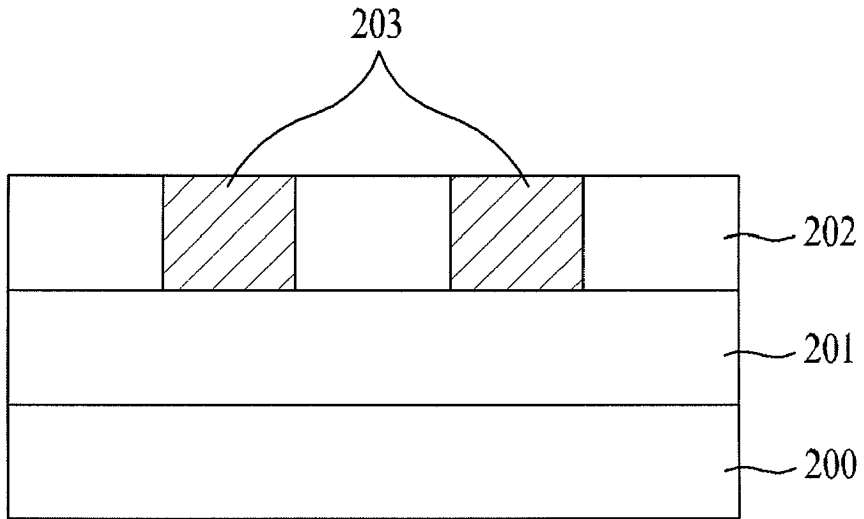

FIG. 4E

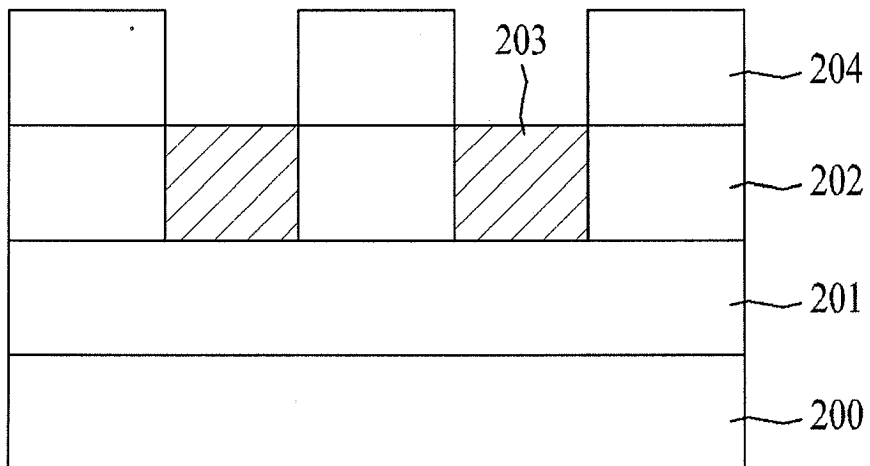

FIG. 4F

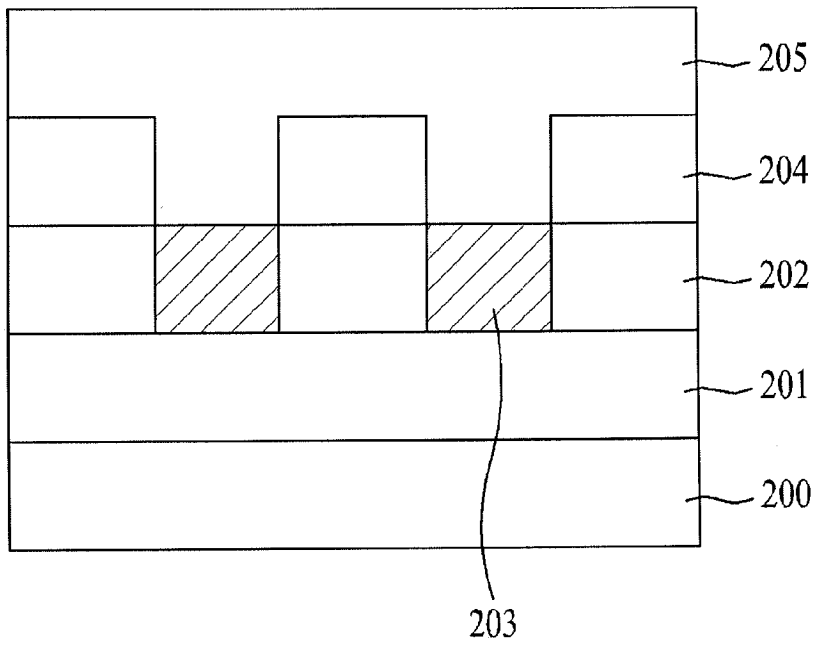

FIG. 4G

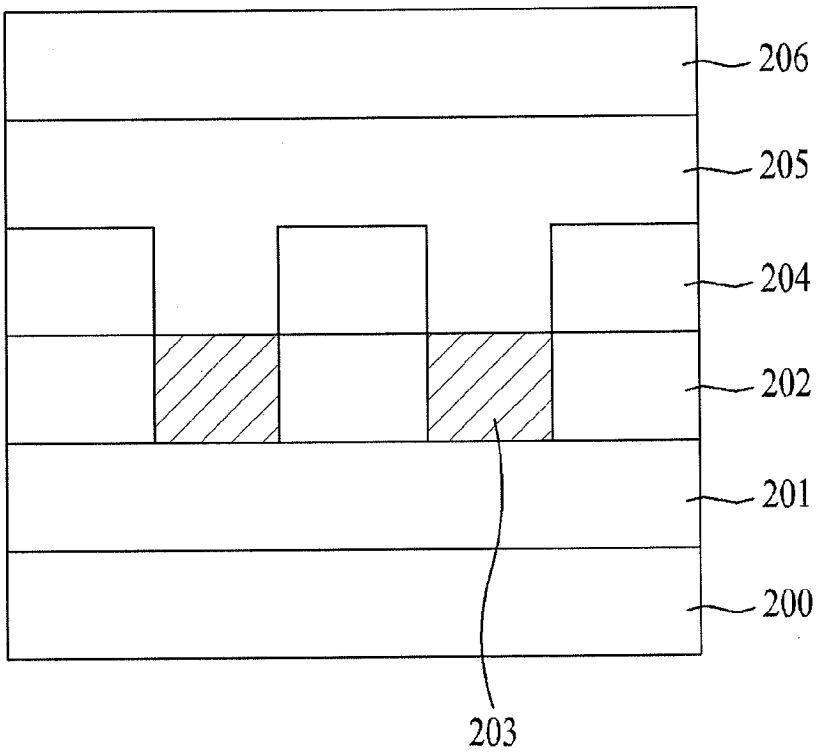

FIG. 5A

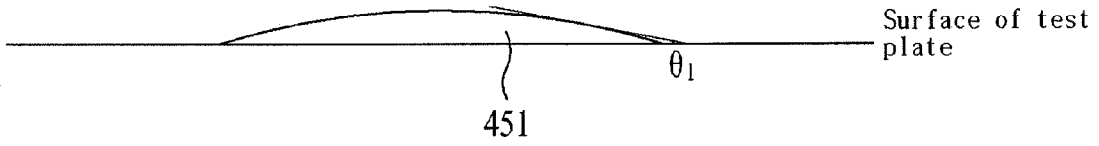

FIG. 5B

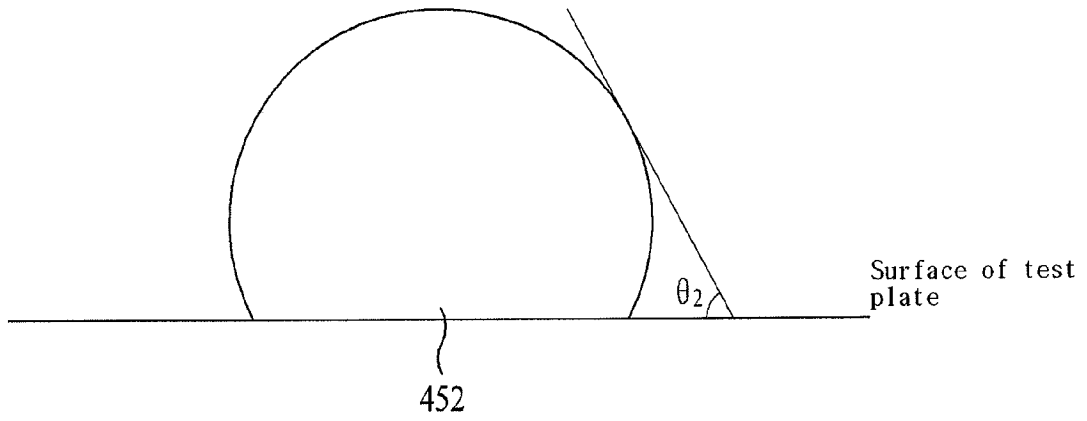

FIG. 5C

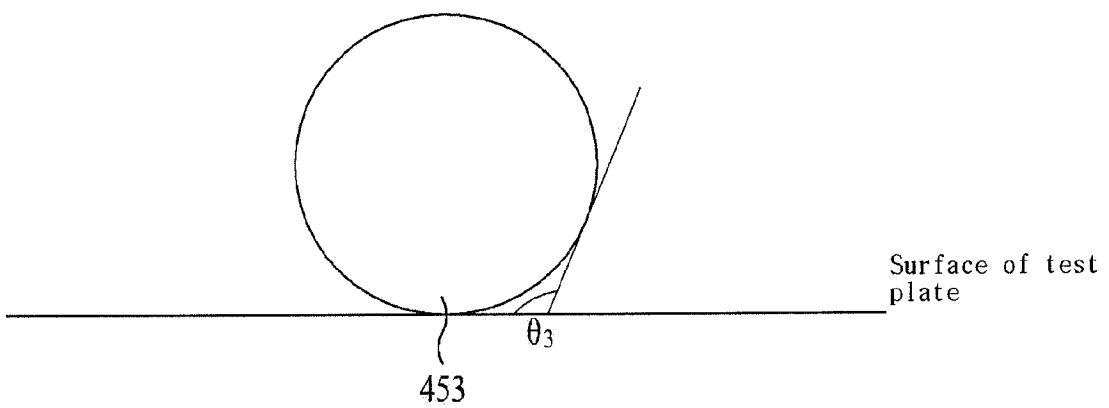

FIG. 6A

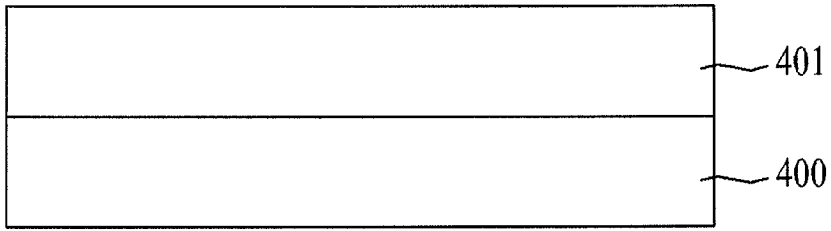

FIG. 6B

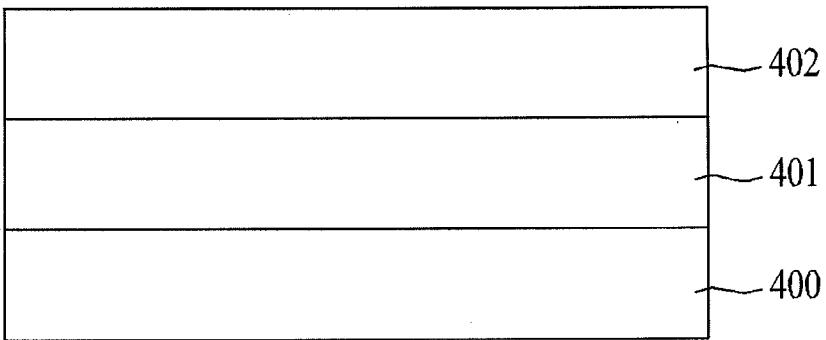

FIG. 6C

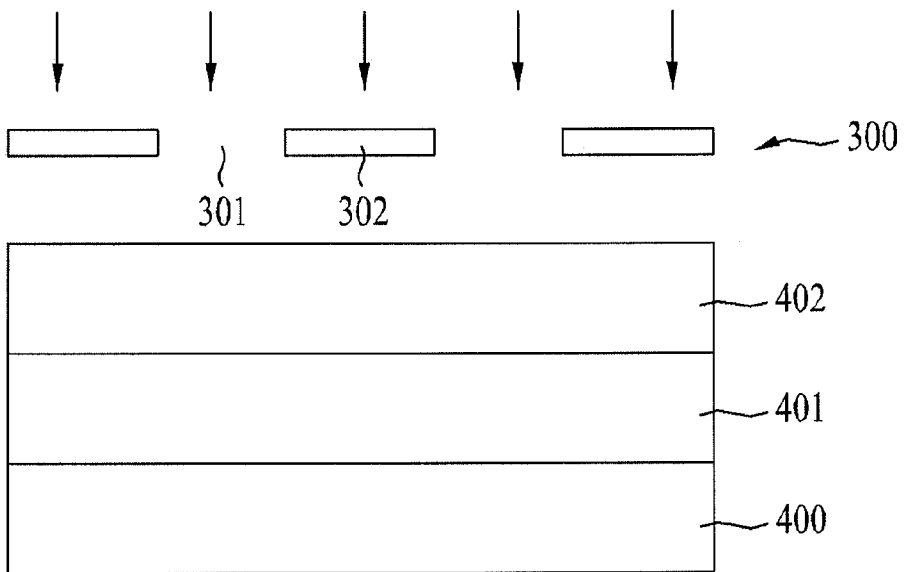

FIG. 6D

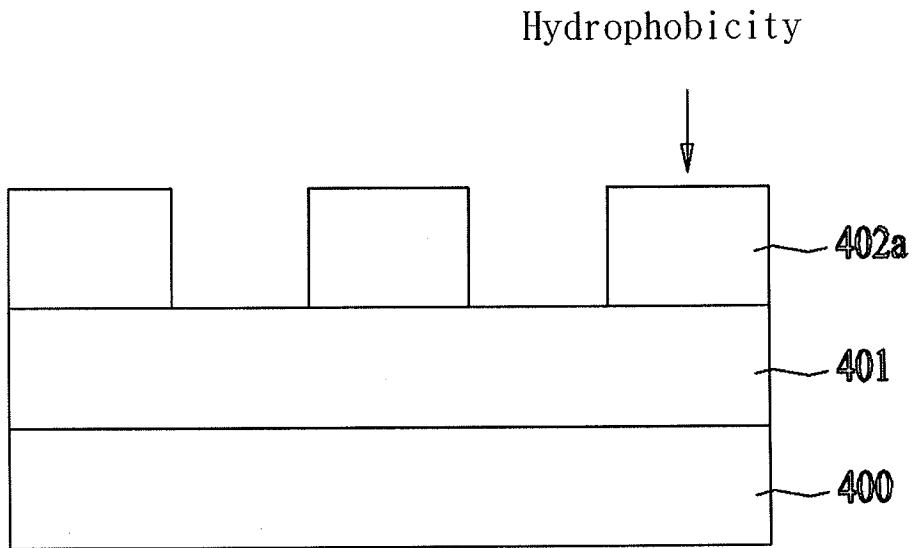

FIG. 6E

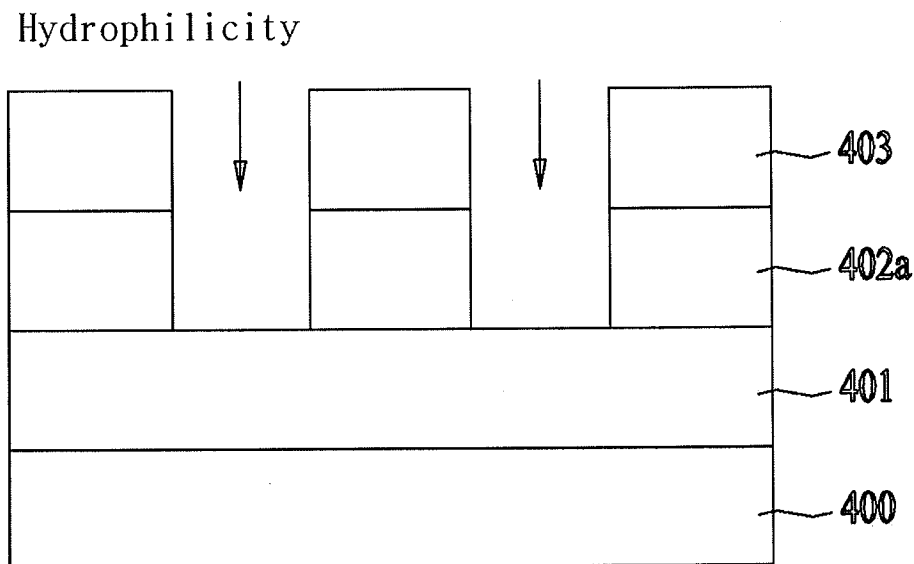

FIG. 6F

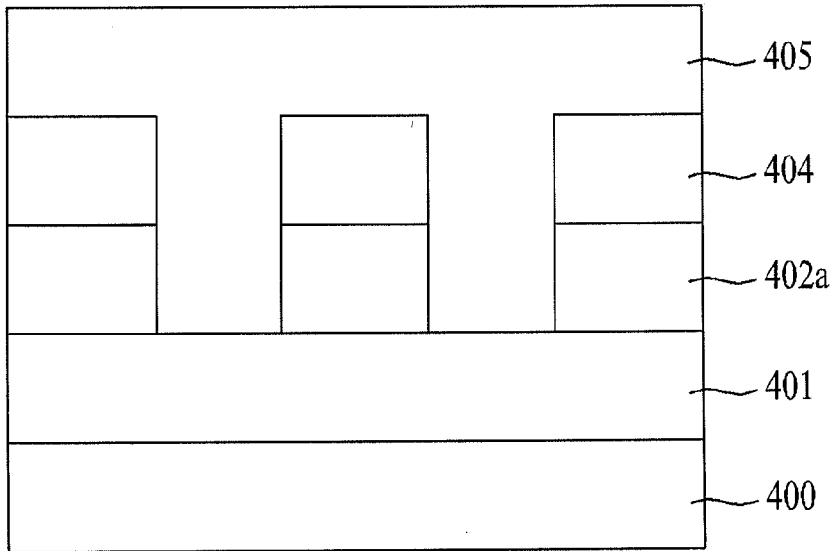
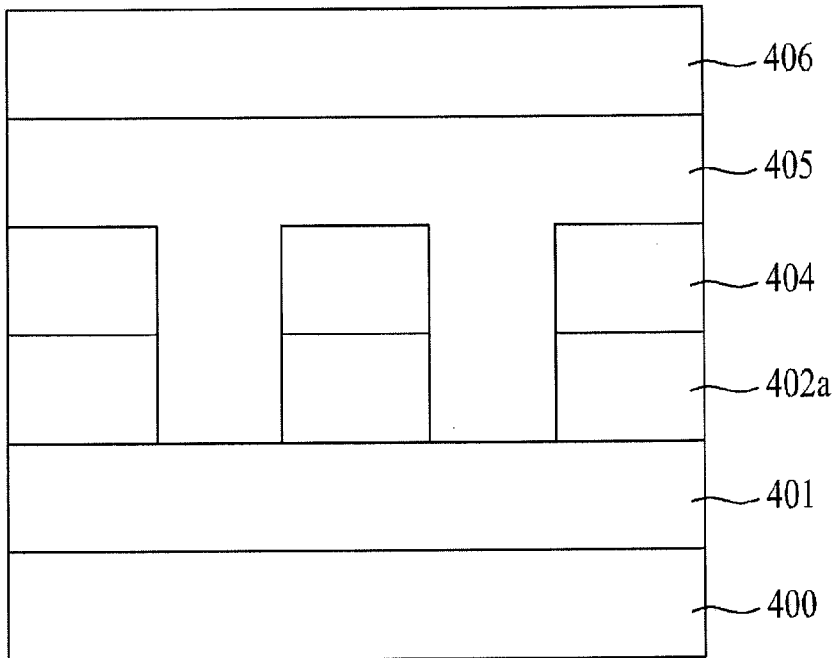

FIG. 6G





EUROPEAN SEARCH REPORT

Application Number  
EP 09 17 5020

DOCUMENTS CONSIDERED TO BE RELEVANT			
Category	Citation of document with indication, where appropriate, of relevant passages	Relevant to claim	CLASSIFICATION OF THE APPLICATION (IPC)
X	US 2007/190885 A1 (AOKI DAIGO [JP]) 16 August 2007 (2007-08-16) * paragraph [0042] - paragraph [0052] * * paragraph [0159] - paragraph [0163]; figures 1a-e *	1,3, 6-11,15	INV. H01L51/00
X	US 2006/087228 A1 (KOBAYASHI YOSHIHIRO [JP]) 27 April 2006 (2006-04-27) * paragraph [0031] - paragraph [0041] * * paragraph [0054] - paragraph [0090] * * paragraph [0128] * * paragraph [0165] - paragraph [0209]; figures 2,4a-d *	1-15	
X	US 2007/248746 A1 (ITO NORIHITO [JP] ET AL) 25 October 2007 (2007-10-25) * paragraph [0051] - paragraph [0064] * * paragraph [0266] - paragraph [0290]; figures 6a-f *	1,3,4, 6-12,15	
			TECHNICAL FIELDS SEARCHED (IPC)
			H01L H05B
The present search report has been drawn up for all claims			
Place of search The Hague		Date of completion of the search 20 April 2010	Examiner Bakos, Tamás
CATEGORY OF CITED DOCUMENTS X : particularly relevant if taken alone Y : particularly relevant if combined with another document of the same category A : technological background O : non-written disclosure P : intermediate document		T : theory or principle underlying the invention E : earlier patent document, but published on, or after the filing date D : document cited in the application L : document cited for other reasons ..... & : member of the same patent family, corresponding document	

2  
EPC FORM 1503 03.82 (F04C01)

**ANNEX TO THE EUROPEAN SEARCH REPORT  
ON EUROPEAN PATENT APPLICATION NO.**

EP 09 17 5020

This annex lists the patent family members relating to the patent documents cited in the above-mentioned European search report.  
The members are as contained in the European Patent Office EDP file on  
The European Patent Office is in no way liable for these particulars which are merely given for the purpose of information.

20-04-2010

Patent document cited in search report	Publication date	Patent family member(s)	Publication date
US 2007190885 A1	16-08-2007	CN 1487776 A	07-04-2004
		GB 2394120 A	14-04-2004
		JP 4165692 B2	15-10-2008
		JP 2004071286 A	04-03-2004
		US 2004075384 A1	22-04-2004
-----			
US 2006087228 A1	27-04-2006	GB 2419740 A	03-05-2006
		JP 2006127783 A	18-05-2006
-----			
US 2007248746 A1	25-10-2007	JP 2007287623 A	01-11-2007
-----			

**REFERENCES CITED IN THE DESCRIPTION**

*This list of references cited by the applicant is for the reader's convenience only. It does not form part of the European patent document. Even though great care has been taken in compiling the references, errors or omissions cannot be excluded and the EPO disclaims all liability in this regard.*

**Patent documents cited in the description**

- KR P1020080133274 [0001]
- KR P1020090061771 [0001]

专利名称(译)	有机发光显示装置及其制造方法		
公开(公告)号	<a href="#">EP2202817A1</a>	公开(公告)日	2010-06-30
申请号	EP2009175020	申请日	2009-11-04
[标]申请(专利权)人(译)	乐金显示有限公司		
申请(专利权)人(译)	LG DISPLAY CO. , LTD.		
当前申请(专利权)人(译)	LG DISPLAY CO. , LTD.		
[标]发明人	LEE KYUNG HOON PARK JONG HYUN PARK TAE HAN JEONG HYUN CHEOL YOO DONG HEE		
发明人	LEE, KYUNG-HOON PARK, JONG-HYUN PARK, TAE-HAN JEONG, HYUN-CHEOL YOO, DONG-HEE		
IPC分类号	H01L51/00 H01L51/56		
CPC分类号	H01L51/0012 H01L51/0015 H01L51/5088 H01L51/56		
代理机构(译)	庆祝活动, JENTSCHURA & PARTNER		
优先权	1020080133274 2008-12-24 KR 1020090061771 2009-07-07 KR		
其他公开文献	EP2202817B1		
外部链接	<a href="#">Espacenet</a>		

摘要(译)

公开了一种具有提高的产率和加工效率的有机发光显示装置，其包括能够在有机层中的空穴注入层（201）的顶部上分离成亲水区域（203）和疏水区域的中间层（202）。发光器件和包括发光层（204）的多个层并且不使用阴影掩模制造，以及制造该发光器件的方法。制造方法包括制备具有以矩阵形式限定的多个像素区域的基板，在每个像素区域中布置阳极（200），通过溶液工艺在阳极（200）上形成空穴注入层（201）通过溶液工艺在空穴注入层（201）上形成具有疏水性的中间层（202），选择性地UV照射中间层（202）以在中间层上形成亲水区域（203），形成发光层（204）通过溶液工艺在中间层（202）上，并在具有发光层（204）的基板上设置阴极（206）。

FIG. 3

