

(19)



(11)

EP 1 814 183 B1

(12)

EUROPEAN PATENT SPECIFICATION

(45) Date of publication and mention
of the grant of the patent:
13.11.2013 Bulletin 2013/46

(51) Int Cl.:
H01L 51/52^(2006.01) H01L 27/32^(2006.01)

(21) Application number: **07250337.8**

(22) Date of filing: **26.01.2007**

(54) Organic light-emitting display device

Organische lichtemittierende Anzeigevorrichtung

Dispositif à affichage électroluminescent organique

(84) Designated Contracting States:
DE FR GB

(30) Priority: **26.01.2006 KR 20060008461**
20.02.2006 KR 20060016187

(43) Date of publication of application:
01.08.2007 Bulletin 2007/31

(73) Proprietor: **Samsung Display Co., Ltd.**
Gyeonggi-Do (KR)

(72) Inventor: **Kwak, Won-Kyu**
Yongin-si
Gyeonggi-do (KR)

(74) Representative: **Mounteney, Simon James**
Marks & Clerk LLP
90 Long Acre
London
WC2E 9RA (GB)

(56) References cited:
EP-A2- 0 971 564 EP-A2- 1 511 081
JP-A- 2005 078 881 US-A1- 2004 263 059

EP 1 814 183 B1

Note: Within nine months of the publication of the mention of the grant of the European patent in the European Patent Bulletin, any person may give notice to the European Patent Office of opposition to that patent, in accordance with the Implementing Regulations. Notice of opposition shall not be deemed to have been filed until the opposition fee has been paid. (Art. 99(1) European Patent Convention).

Description

1. Field

[0001] The present invention relates to display technologies, and more particularly to an organic light-emitting display device.

2. Discussion of Related Technologies

[0002] In general, an organic light-emitting display device comprises a first substrate, and a second substrate opposing the first substrate and a sealing structure. The sealing structure combines the first and second substrates, which in combination form an enclosed space. The sealing structure often is made of a material such as epoxy. The organic light-emitting display device further includes an array of organic light-emitting diodes within the enclosed space.

[0003] However, since the organic light-emitting diodes include organic materials, it may be vulnerable to moisture. Further, since one or more electrically conductive lines formed in the array are made of metallic materials, the lines may be easily oxidized by oxygen contained in the air, which can deteriorate their electrical characteristics and light-emitting characteristics of the display device. To prevent this, a moisture absorbent can be mounted within the enclosed space as an approach.

[0004] However, mounting the moisture absorbent in the display device is not without problems. As an alternative or in addition, more hermetic sealing can be introduced using glass frit substituting a conventional sealant. U.S. Patent No. 6,998,776 discloses glass frit to encapsulate an organic light-emitting device.

[0005] EP0971564 discloses an organic electroluminescent (EL) display panel which has a protective cover sealed thereon with a radiation-cured perimeter seal. The organic EL display panel is formed on a radiation-transmissive substrate, and includes at least one metallized leader which is in electrical contact with at least one anode electrode or with at least one cathode electrode. The metallized leader has a patterned seal zone which defines radiation-transmissive apertures.

SUMMARY OF THE INVENTION

[0006] The present invention sets out to solve the above problems and provides an organic light-emitting display device as set out in Claim 1 and a method of manufacturing an organic display device as set out in Claim 17. Preferred features of the invention are set out in Claims 2 to 16.

BRIEF DESCRIPTION OF THE DRAWINGS

[0007] These and/or other advantages of the invention will become apparent and more readily appreciated from the following description of various embodiments, taken

in conjunction with the accompanying drawings in which:

[0008] FIG. 1 illustrates a first substrate and an array of organic light-emitting pixels formed on the first substrate according to an embodiment of the present invention;

[0009] FIG. 2a and FIG. 2b illustrate a second substrate with a frit sealing structure formed thereon;

[0010] FIG. 3 is a schematic view showing the first and second substrates when interconnected.;

10 [0011] FIG. 4 is a side view showing an electrically conductive line formed on a substrate of an organic light-emitting device;

[0012] FIG. 5a is a side view of an electrically conductive line formed on a substrate of an organic light-emitting device with a meniscus formed by selective etching;

15 [0013] FIG. 5b is a photograph of a cross-section of an area where the electrically conductive line of FIG. 5a is overlapped with a frit seal;

[0014] FIG. 6 is a schematic view showing an intersecting region of the frit and the electrically conductive line (not forming an embodiment of the present invention);

20 [0015] FIGS. 7a, 7b, 8, 9a and 9b illustrate alternative embodiments of electrically conductive lines as illustrated in FIG. 6;

[0016] FIG. 10A is a schematic exploded view of a passive matrix type organic light emitting display device;

[0017] FIG. 10B is a schematic exploded view of an active matrix type organic light emitting display device;

30 [0018] FIG. 10C is a schematic top plan view of an organic light emitting display;

[0019] FIG. 10D is a cross-sectional view of the organic light emitting display of FIG. 10C, taken along the line d-d; and

35 [0020] FIG. 10E is a schematic perspective view illustrating mass production of organic light emitting devices.

DETAILED DESCRIPTION OF EMBODIMENTS

40 [0021] Hereinafter, embodiments of the present invention will be described by way of example and with reference to the accompanying drawings. In the drawings, like reference numerals refer to like elements throughout.

[0022] An organic light emitting display (OLED) is a display device comprising an array of organic light emitting diodes. Organic light emitting diodes are solid state devices which include an organic material and are adapted to generate and emit light when appropriate electrical potentials are applied.

50 [0023] OLEDs can be generally grouped into two basic types dependent on the arrangement with which the stimulating electrical current is provided. Fig. 10A schematically illustrates an exploded view of a simplified structure of a passive matrix type OLED 1000. Fig. 10B schematically illustrates a simplified structure of an active matrix type OLED 1001. In both configurations, the OLED 1000, 1001 includes OLED pixels built over a substrate 1002, and the OLED pixels include an anode 1004, a cathode

1006 and an organic layer 1010. When an appropriate electrical current is applied to the anode 1004, electric current flows through the pixels and visible light is emitted from the organic layer.

[0024] Referring to Fig. 10A, the passive matrix OLED (PMOLED) design includes elongate strips of anode 1004 arranged generally perpendicular to elongate strips of cathode 1006 with organic layers interposed therebetween. The intersections of the strips of cathode 1006 and anode 1004 define individual OLED pixels where light is generated and emitted upon appropriate excitation of the corresponding strips of anode 1004 and cathode 1006. PMOLEDs provide the advantage of relatively simple fabrication.

[0025] Referring to Fig. 10B, the active matrix OLED (AMOLED) includes local driving circuits 1012 arranged between the substrate 1002 and an array of OLED pixels. An individual pixel of AMOLEDs is defined between the common cathode 1006 and an anode 1004, which is electrically isolated from other anodes. Each driving circuit 1012 is coupled with an anode 1004 of the OLED pixels and further coupled with a data line 1016 and a scan line 1018. The scan lines 1018 supply scan signals that select rows of the driving circuits, and the data lines 1016 supply data signals for particular driving circuits. The data signals and scan signals stimulate the local driving circuits 1012, which excite the anodes 1004 so as to emit light from their corresponding pixels.

[0026] In the illustrated AMOLED, the local driving circuits 1012, the data lines 1016 and scan lines 1018 are buried in a planarization layer 1014, which is interposed between the pixel array and the substrate 1002. The planarization layer 1014 provides a planar top surface on which the organic light emitting pixel array is formed. The planarization layer 1014 may be formed of organic or inorganic materials, and formed of two or more layers although shown as a single layer. The local driving circuits 1012 are typically formed with thin film transistors (TFT) and arranged in a grid or array under the OLED pixel array. The local driving circuits 1012 may be at least partly made of organic materials, including organic TFT. AMOLEDs have the advantage of fast response time improving their desirability for use in displaying data signals. Also, AMOLEDs have the advantages of consuming less power than passive matrix OLEDs.

[0027] Referring to common features of the PMOLED and AMOLED designs, the substrate 1002 provides structural support for the OLED pixels and circuits. The substrate 1002 can comprise rigid or flexible materials as well as opaque or transparent materials, such as plastic, glass, and/or foil. As noted above, each OLED pixel or diode is formed with the anode 1004, cathode 1006 and organic layer 1010 interposed therebetween. When an appropriate electrical current is applied to the anode 1004, the cathode 1006 injects electrons and the anode 1004 injects holes. In certain cases, the anode 1004 and cathode 1006 are inverted; i.e., the cathode is formed on the substrate 1002 and the anode is opposingly ar-

ranged.

[0028] Interposed between the cathode 1006 and anode 1004 are one or more organic layers. More specifically, at least one emissive or light emitting layer is interposed between the cathode 1006 and anode 1004. The light emitting layer may comprise one or more light emitting organic compounds. Typically, the light emitting layer is configured to emit visible light in a single color such as blue, green, red or white. In the illustrated device, one organic layer 1010 is formed between the cathode 1006 and anode 1004 and acts as a light emitting layer. Additional layers, which can be formed between the anode 1004 and cathode 1006, can include a hole transporting layer, a hole injection layer, an electron transporting layer and an electron injection layer.

[0029] Hole transporting and/or injection layers can be interposed between the light emitting layer 1010 and the anode 1004. Electron transporting and/or injecting layers can be interposed between the cathode 1006 and the light emitting layer 1010. The electron injection layer facilitates injection of electrons from the cathode 1006 toward the light emitting layer 1010 by reducing the work function for injecting electrons from the cathode 1006. Similarly, the hole injection layer facilitates injection of holes from the anode 1004 toward the light emitting layer 1010. The hole and electron transporting layers facilitate movement of the carriers injected from the respective electrodes toward the light emitting layer.

[0030] In some cases, a single layer may serve both electron injection and transportation functions or both hole injection and transportation functions. In some cases, one or more of these layers are lacking. In some cases, one or more organic layers are doped with one or more materials that help injection and/or transportation of the carriers. In structures where only one organic layer is formed between the cathode and anode, the organic layer may include not only an organic light emitting compound but also certain functional materials that help injection or transportation of carriers within that layer.

[0031] There are numerous organic materials that have been developed for use in these layers including the light emitting layer. Also, numerous other organic materials for use in these layers are being developed. In some cases, these organic materials may be macromolecules including oligomers and polymers. In some cases, the organic materials for these layers may be relatively small molecules. The skilled artisan will be able to select appropriate materials for each of these layers in view of the desired functions of the individual layers and the materials for the neighboring layers in particular designs.

[0032] In operation, an electrical circuit provides appropriate potential between the cathode 1006 and anode 1004. This results in an electrical current flowing from the anode 1004 to the cathode 1006 via the interposed organic layer(s). In one structure, the cathode 1006 provides electrons to the adjacent organic layer 1010. The anode 1004 injects holes to the organic layer 1010. The holes and electrons recombine in the organic layer 1010

and generate energy particles called "excitons." The excitons transfer their energy to the organic light emitting material in the organic layer 1010, and the energy is used to emit visible light from the organic light emitting material. The spectral characteristics of light generated and emitted by the OLED 1000, 1001 depend on the nature and composition of organic molecules in the organic layer(s). The composition of the one or more organic layers can be selected to suit the needs of a particular application by one of ordinary skill in the art.

[0033] OLED devices can also be categorized based on the direction of the light emission. In one type referred to as "top emission" type, OLED devices emit light and display images through the cathode or top electrode 1006. In these devices, the cathode 1006 is made of a material transparent or at least partially transparent with respect to visible light. In certain cases, to avoid losing any light that can pass through the anode or bottom electrode 1004, the anode may be made of a material substantially reflective of the visible light. A second type of OLED devices emits light through the anode or bottom electrode 1004 and is called "bottom emission" type. In the bottom emission type OLED devices, the anode 1004 is made of a material which is at least partially transparent with respect to visible light. Often, in bottom emission type OLED devices, the cathode 1006 is made of a material substantially reflective of the visible light. A third type of OLED devices emits light in two directions, e.g. through both anode 1004 and cathode 1006. Depending upon the direction(s) of the light emission, the substrate may be formed of a material which is transparent, opaque or reflective of visible light.

[0034] In many structures, an OLED pixel array 1021 comprising a plurality of organic light emitting pixels is arranged over a substrate 1002 as shown in Fig. 10C. The pixels in the array 1021 are controlled to be turned on and off by a driving circuit (not shown), and the plurality of the pixels as a whole displays information or image on the array 1021. In certain cases, the OLED pixel array 1021 is arranged with respect to other components, such as drive and control electronics to define a display region and a non-display region. In these structures, the display region refers to the area of the substrate 1002 where OLED pixel array 1021 is formed. The non-display region refers to the remaining areas of the substrate 1002. The non-display region can contain logic and/or power supply circuitry. It will be understood that there will be at least portions of control/drive circuit elements arranged within the display region. For example, in PMOLEDs, conductive components will extend into the display region to provide appropriate potential to the anode and cathodes. In AMOLEDs, local driving circuits and data/scan lines coupled with the driving circuits will extend into the display region to drive and control the individual pixels of the AMOLEDs.

[0035] One design and fabrication consideration in OLED devices is that certain organic material layers of OLED devices can suffer damage or accelerated deteri-

oration from exposure to water, oxygen or other harmful gases. Accordingly, it is generally understood that OLED devices be sealed or encapsulated to inhibit exposure to moisture and oxygen or other harmful gases found in a manufacturing or operational environment. Fig. 10D schematically illustrates a cross-section of an encapsulated OLED device 1011 having a layout of Fig. 10C and taken along the line d-d of Fig. 10C. In this device, a generally planar top plate or substrate 1061 engages with a seal 1071 which further engages with a bottom plate or substrate 1002 to enclose or encapsulate the OLED pixel array 1021. In other structures, one or more layers are formed on the top plate 1061 or bottom plate 1002, and the seal 1071 is coupled with the bottom or top substrate 1002, 1061 via such a layer. In the illustrated device, the seal 1071 extends along the periphery of the OLED pixel array 1021 or the bottom or top plate 1002, 1061.

[0036] The seal 1071 is made of a frit material as will be further discussed below. In various structures, the top and bottom plates 1061, 1002 comprise materials such as plastics, glass and/or metal foils which can provide a barrier to passage of oxygen and/or water to thereby protect the OLED pixel array 1021 from exposure to these substances. At least one of the top plate 1061 and the bottom plate 1002 are formed of a substantially transparent material.

[0037] To lengthen the life time of OLED devices 1011, it is generally desired that seal 1071 and the top and bottom plates 1061, 1002 provide a substantially non-permeable seal to oxygen and water vapor and provide a substantially hermetically enclosed space 1081. In certain applications, it is indicated that the seal 1071 of a frit material in combination with the top and bottom plates 1061, 1002 provide a barrier to oxygen of less than approximately 10^{-3} cc/m²-day and to water of less than 10^{-6} g/m²-day. Given that some oxygen and moisture can permeate into the enclosed space 1081, in some cases, a material that can take up oxygen and/or moisture is formed within the enclosed space 1081.

[0038] The seal 1071 has a width W, which is its thickness in a direction parallel to a surface of the top or bottom substrate 1061, 1002 as shown in Fig. 10D. The width varies among devices and ranges from about 300 μ m to about 3000 μ m, optionally from about 500 μ m to about 1500 μ m. Also, the width may vary at different positions of the seal 1071. In some cases, the width of the seal 1071 may be the largest where the seal 1071 contacts one of the bottom and top substrate 1002, 1061 or a layer formed thereon. The width may be the smallest where the seal 1071 contacts the other. The width variation in a single cross-section of the seal 1071 relates to the cross-sectional shape of the seal 1071 and other design parameters.

[0039] The seal 1071 has a height H, which is its thickness in a direction perpendicular to a surface of the top or bottom substrate 1061, 1002 as shown in Fig. 10D. The height varies among devices and ranges from about

2 μm to about 30 μm , optionally from about 10 μm to about 15 μm . Generally, the height does not significantly vary at different positions of the seal 1071. However, in certain cases, the height of the seal 1071 may vary at different positions thereof.

[0040] In the illustrated structure, the seal 1071 has a generally rectangular cross-section. In other cases, however, the seal 1071 can have other various cross-sectional shapes such as a generally square cross-section, a generally trapezoidal cross-section, a cross-section with one or more rounded edges, or other configuration as indicated by the needs of a given application. To improve hermeticity, it is generally desired to increase the interfacial area where the seal 1071 directly contacts the bottom or top substrate 1002, 1061 or a layer formed thereon. In some structures, the shape of the seal can be designed such that the interfacial area can be increased.

[0041] The seal 1071 can be arranged immediately adjacent the OLED array 1021, and in other structures, the seal 1071 is spaced some distance from the OLED array 1021. In certain cases, the seal 1071 comprises generally linear segments that are connected together to surround the OLED array 1021. Such linear segments of the seal 1071 can extend, in certain cases, generally parallel to respective boundaries of the OLED array 1021. In other structures, one or more of the linear segments of the seal 1071 are arranged in a non-parallel relationship with respective boundaries of the OLED array 1021. In yet other structures, at least part of the seal 1071 extends between the top plate 1061 and bottom plate 1002 in a curvilinear manner.

[0042] As noted above, in certain cases, the seal 1071 is formed using a frit material or simply "frit" or glass frit," which includes fine glass particles. The frit particles includes one or more of magnesium oxide (MgO), calcium oxide (CaO), barium oxide (BaO), lithium oxide (Li_2O), sodium oxide (Na_2O), potassium oxide (K_2O), boron oxide (B_2O_3), vanadium oxide (V_2O_5), zinc oxide (ZnO), tellurium oxide (TeO_2), aluminum oxide (Al_2O_3), silicon dioxide (SiO_2), lead oxide (PbO), tin oxide (SnO), phosphorous oxide (P_2O_5), ruthenium oxide (Ru_2O), rutherfordium oxide (Rf_2O), rhodium oxide (Rh_2O), ferrite oxide (Fe_2O_3), copper oxide (CuO), titanium oxide (TiO_2), tungsten oxide (WO_3), bismuth oxide (Bi_2O_3), antimony oxide (Sb_2O_3), lead-borate glass, tin-phosphate glass, vanadate glass, and borosilicate, etc. These particles range in size from about 2 μm to about 30 μm , optionally about 5 μm to about 10 μm , although not limited only thereto. The particles can be as large as about the distance between the top and bottom substrates 1061, 1002 or any layers formed on these substrates where the frit seal 1071 contacts.

[0043] The frit material used to form the seal 1071 can also include one or more filler or additive materials. The filler or additive materials can be provided to adjust an overall thermal expansion characteristic of the seal 1071 and/or to adjust the absorption characteristics of the seal

1071 for selected frequencies of incident radiant energy. The filler or additive material(s) can also include inversion and/or additive fillers to adjust a coefficient of thermal expansion of the frit. For example, the filler or additive materials can include transition metals, such as chromium (Cr), iron (Fe), manganese (Mn), cobalt (Co), copper (Cu), and/or vanadium. Additional materials for the filler or additives include ZnSiO_4 , PbTiO_3 , ZrO_2 , eucryptite.

[0044] A frit material as a dry composition contains glass particles from about 20 to 90 about wt%, and the remaining includes fillers and/or additives. In some cases, the frit paste contains about 10-30 wt% organic materials and about 70-90% inorganic materials. In some cases, the frit paste contains about 20 wt% organic materials and about 80 wt% organic materials. In some cases, the organic materials may include about 0-30 wt% binder(s) and about 70-100 wt% solvent(s). In some cases, about 10 wt% is binder(s) and about 90 wt% is solvent (s) among the organic materials. In some cases, the inorganic materials may include about 0-10 wt% additives, about 20-40 wt% fillers and about 50-80 wt% glass powder. In some cases, about 0-5 wt% is additive(s), about 25-30 wt% is filler(s) and about 65-75 wt% is the glass powder among the inorganic materials.

[0045] In forming a frit seal, a liquid material is added to the dry frit material to form a frit paste. Any organic or inorganic solvent with or without additives can be used as the liquid material. Typically, the solvent includes one or more organic compounds. For example, applicable organic compounds are ethyl cellulose, nitro cellulose, hydroxyl propyl cellulose, butyl carbitol acetate, terpineol, butyl cellulose, acrylate compounds. Then, the thus formed frit paste can be applied to form a shape of the seal 1071 on the top and/or bottom plate 1061, 1002.

[0046] The shape of the seal 1071 is initially formed from the frit paste and interposed between the top plate 1061 and the bottom plate 1002. The seal 1071 can in certain cases be pre-cured or pre-sintered to one of the top plate and bottom plate 1061, 1002. Following assembly of the top plate 1061 and the bottom plate 1002 with the seal 1071 interposed therebetween, portions of the seal 1071 are selectively heated such that the frit material forming the seal 1071 at least partially melts. The seal 1071 is then allowed to resolidify to form a secure joint between the top plate 1061 and the bottom plate 1002 to thereby inhibit exposure of the enclosed OLED pixel array 1021 to oxygen or water.

[0047] Typically, the selective heating of the frit seal is carried out by irradiation of light, such as a laser or directed infrared lamp. As previously noted, the frit material forming the seal 1071 can be combined with one or more additives or filler such as species selected for improved absorption of the irradiated light to facilitate heating and melting of the frit material to form the seal 1071.

[0048] Typically, OLED devices 1011 are mass produced. In an arrangement illustrated in Fig. 10E, a plurality of separate OLED arrays 1021 is formed on a common bottom substrate 1101. In the case embodiment,

each OLED array 1021 is surrounded by a shaped frit to form the seal 1071. A common top substrate (not shown) is placed over the common bottom substrate 1101 and the structures formed thereon such that the OLED arrays 1021 and the shaped frit paste are interposed between the common bottom substrate 1101 and the common top substrate. The OLED arrays 1021 are encapsulated and sealed, such as via the previously described enclosure process for a single OLED display device. The resulting product includes a plurality of OLED devices kept together by the common bottom and top substrates. Then, the resulting product is cut into a plurality of pieces, each of which constitutes an OLED device 1011 of Fig. 10D. In certain cases, the individual OLED devices 1011 then further undergo additional packaging operations to further improve the sealing formed by the frit seal 1071 and the top and bottom substrates 1061, 1002.

[0049] Referring to FIG. 1, a first substrate 200 is comprised of a pixel region 210 and a non-pixel region 220. The pixel region 210 is provided with a plurality of organic light-emitting pixels, each of which is connected with a scan line 104b and a data line 106c. The non-pixel region 220 is provided with a scan driver 410 connected with the scan lines 104b and a data driver 420 connected with the data lines 106c. The non-pixel region 220 is further provided with a power supplying line (or metal line: not shown) for supplying power to various circuits.

[0050] Each pixel comprises an organic light-emitting diode (not shown). In some embodiments, each pixel is connected to at least one thin film transistor for driving the organic light-emitting diode. The organic light-emitting diode comprises an anode electrode, a cathode electrode and organic layers located between the anode and cathode electrodes. The organic layers comprise at least one light-emitting layer and may further comprise one or more of a hole transporting layer, and an electron transporting layer, etc. The thin film transistor comprises a gate electrode, a source electrode and a drain electrode. The transistor controls the amount of current supplied to the organic light-emitting diode. In operation, a pixel 100 is selected when a scan signal and a data signal are applied to that pixel. The selected pixel 100 emits light.

[0051] Referring to FIGS. 2A and 2B, the second substrate 300 is provided with a frit 320 that is to bond to the first substrate 200. For example, the frit 320 is formed using a method as described now. In general, the frit in the form of glass powder is produced by rapidly falling temperature in the course of heating glass material at high temperature. The frit powder is mixed with organic fillers so as to form a frit paste. The paste is applied onto the second substrate 300 in a desired structure such as shown in FIGS. 2A and 2B. The second substrate 300 and the paste structure are heated at a predetermined temperature so as to cure the frit and fix it to the second substrate 300. Here, the temperature for curing the frit 320 is approximately 300 °C to 500 °C. In some embodiments, the frit 320 has the height of about 14 to about 15 μm and the width of about 0.6 to about 0.7mm.

[0052] Referring to FIG. 3, the frit 320 is interposed between and bonds the first substrate 200 and the second substrate 300. The frit 320 is irradiated with infrared rays or laser beams so that at least part of the frit 320 is melted and bonded to the first substrate 200, thereby bonding the first substrate and the second substrate. As above, the first substrate 200 and the second substrate 300 are substantially hermetically bonded with the frit 320, thereby preventing oxygen and moisture, etc., from inflicting into the pixel region 210.

[0053] Meanwhile, when the first substrate 200 is bonded to the second substrate 300, the frit 320 is overlapped with at least one of electrically conductive lines. For example, the frit 320 is overlapped with electrically conductive lines such as the scan lines 104b, the data lines 106c, the power supply lines, etc. Here, at least some of the electrically conductive lines are formed when the thin film transistors and the organic light-emitting diodes are formed. In some embodiments, the electrically conductive lines are made simultaneously with gate electrodes, source or drain electrodes and anodes for the light-emitting pixels. Therefore, the electrically conductive lines may be in the same materials as those circuit elements. For example, the scan lines 104 can be made of the gate metal, and the data lines 106c and the power supply lines can be made of the source/drain metals. In other embodiments, the electrically conductive lines can be made of the same substance as the semiconductor layer of the thin film transistors. In embodiments, the frit 320 can be formed in various sizes and configurations. For example, the frit 320 can surround or exclude the scan driver 410.

[0054] Referring to FIG. 4, the electrically conductive line 400 is manufactured in the form of three layers including different kinds of metal substances. For example, the electrically conductive line 400 comprises a first metal film 401a, a second metal film 401b and a third metal film 401c. In some embodiments, the first metal film 401a and the third metal film 401c are made of the same substances, and the second metal film 401b is made of a substance different from the first metal film 401a and the third metal film 401c. For example, the first film 401a and the third film metal 401c are made of titanium (Ti) or molybdenum (Mo). For example, the second metal film 401b is made of aluminum (Al) having good conductivity. As above, the electrically conductive line 400 is manufactured in the form of three layers, capable of improving the electrical characteristics such as conductivity, etc. Also, the multiple layer construction may minimize unwanted chemical reactions with materials adjacent the conductive line. During the manufacturing of the organic light-emitting display device, the electrically conductive line 400 is subject to at least one or more etching processes. In such etching processes the first metal film 401a and the second metal film 401b made of different metals are etched at different rates. As illustrated in FIG. 5A and FIG. 5B, the second metal film 401b made of aluminum (Al) is more easily etched than the first and third metal

films 401 a and 401c, thereby forming a meniscus 402 on the side of the electrically conductive line 400. The meniscus 402 viewed from another direction (not illustrated) extends along the conductive line and forms a groove. The terms "meniscus" and "groove" are interchangeably used hereinafter. In particular, as the groove 402 is subject to a washing process after etching, it may become larger.

[0055] FIG. 5B illustrates the electrically conductive line with the meniscus 402 in the second metal film 401b along with frit 320 formed over the conductive line. As illustrated, the meniscus 402 and the frit next thereto together form a hole 412, which extends along the extension of the electrically conductive line. This hole may interconnect inside and outside of the space enclosed by the two substrates and the frit, and can provide a channel through which moisture or air can travel. The moisture and/or air reaching the enclosed space may react with materials of important elements of the organic light-emitting device, and may significantly reduce the longevity of the device.

[0056] Referring to FIG. 6, the electrically conductive line 400 include certain geometrical structures along both edges of a portion thereof which overlaps with the frit 320. The illustrated geometrical structures comprise protrusions from an otherwise straight edge line of the portion. The adjacent protrusions are separated with an interval such that the geometrical structures are viewed as a plurality of protrusions and a plurality of recesses. Although not illustrated, the electrically conductive line under the geometric structures may still have the meniscus 402 (FIG 5A) along the edge thereof. Therefore, the meniscus 402 and the frit 320 next thereto may form one or more passages or channels that can allow travel of moisture or air therethrough. In certain embodiments, the geometric structures may be formed only on one of the edges. With the foregoing geometric structures, the length of the edges is substantially longer than that without such structures. The longer edges of the conductive line 400 makes the penetration of moisture or air less likely or less severe. This is because the longer the edge is, the longer the channel or passage interconnecting the inside and outside of the frit, if at all. Also, in some situations, the channel or passage may be blocked by a portion of the frit 320 or by collapse of portions of the geometric structures at one or more locations thereof. In such situations, moisture or air may not reach the space enclosed by the two substrates and the frit.

[0057] The geometric structures may be formed in various shapes and configurations as long as their existence increases the length of the edges of the conductive line 400 where it overlaps with the frit 320. For example, the geometric structures may be shaped and configured as illustrated in FIG. 7A. The illustrated structures include a protrusion 405a from the main body of the conductive line 400 and an extension 405b contacting the protrusion 405a. The extension 405b extends in a direction along the main body of the conductive line 400 and is longer

than the protrusion 405a in that direction. Overall, the length of the edge line of the geometric structures is significantly longer than the length of the otherwise edge 414 of the conductive line without the geometric structures.

[0058] Referring to FIG. 7B, the geometric structures further include portions 405c connected to the extension 405b of FIG. 7A. These additional portions further increase the length of the edge line of the conductive line 400.

[0059] The geometric structures formed along the edge of the electrically conductive line may also be used in electronic devices other than the organic light-emitting display device. Also, the geometric structures may be used with other forms of sealing of organic light-emitting devices or other electronic devices. Such other forms of sealing include epoxy.

[0060] FIGS. 8, 9A and 9B provide additional examples of the geometric structures that can be formed along the edges of electrically conductive lines that can be overlapping with frit or other forms of sealing. More specifically, FIG. 8 illustrates the same geometric structures as FIG. 6 with the difference that the recesses of FIG. 8 are formed into the body of the conductive line 400. FIGS. 9A and 9B provides negative geometric structures 502a, 502b, 502c that are formed into the body of the conductive line 400 while lengthening the edge line thereof. In the illustrated embodiments, the electrically conductive line 400 intersects with the frit 320 or other forms of sealing substantially perpendicular to each other. However, in other embodiments, the intersection between the electrically conductive line 400 and the frit 320 may be at other angles. Furthermore, different types of negative structures may be framed on opposite sides of the conductive line and/or be formed together on the same side of the conductive line. The geometric structures need not be formed on both sides of the conductive line, but could just be formed on one side.

[0061] Although certain embodiments have been shown and described, one of ordinary skill in the art will appreciate that changes might be made in these embodiments without departing from the principles of the invention, the scope of which is defined in the claims and their equivalents.

Claims

1. An organic light-emitting display device comprising:
 - a first substrate (200);
 - a second substrate (300);
 - a frit seal interconnecting (320) the first and second substrate (200, 300); and
 - an electrically conductive line (400) formed on the first substrate (200) and comprising a portion overlapping with the frit seal (320), wherein the portion of the electrically conductive line (400)

- comprises a first edge with first geometrical structures such that the length along the first edge with the first geometrical structures is substantially longer than it would be without the first geometrical structures;
 wherein the first geometrical structures comprise a protrusion **characterised in that** the first geometrical structure comprises an extension from the protrusion, wherein the extension of the first geometrical structures extends in a direction substantially parallel to the portion of the electrically conductive line (400).
2. A device according to Claim 1, wherein the first substrate (200), the second substrate (300) and the frit seal (320) define an enclosed space, wherein the electrically conductive line (400) interconnects a first circuit located within the enclosed space and a second circuit located outside the enclosed space.
 3. A device according to Claim 1 or 2, wherein the portion further comprises a second edge generally parallel to the first edge, wherein the second edge comprises second geometrical structures such that the length along the second edge with the second geometrical structures is substantially longer than it would be without the second geometrical structures.
 4. A device according to claim 3, wherein the second geometrical structures comprise at least one of a protrusion and a recess.
 5. A device according to any preceding claim, wherein the first and/or second geometrical structures respectively provide a plurality of turns along the edge.
 6. A device according to any preceding claim, wherein the second geometrical structures comprise a protrusion and an extension from the protrusion, wherein the extension of the second geometrical structure extends in a direction substantially parallel to the portion of the electrically conductive line (400).
 7. A device according to any preceding claim, wherein the first and/or second geometrical structures respectively comprise a recess into conductive line and a canal extending from the recess, wherein the canal extends in a direction substantially parallel to the portion of the electrically conductive line.
 8. A device according to any preceding claim, wherein the electrically conductive line (400) comprises two or more lasers.
 9. A device according to Claim 8, wherein the electrically conductive line (400) comprises an interposed layer interposed between two conductive layers.
 10. A device according to Claim 9, wherein each of the two conductive layers comprise a common material.
 11. A device according to any preceding claim, wherein the electrically conductive line comprises a layered structure of titanium (Ti)/aluminium (Al)/titanium (Ti) or molybdenum (Mo)/aluminum (Al)/molybdenum (Mo).
 12. A device according to any preceding claim, wherein the electrically conductive line (400) does not comprise through holes therein.
 13. A device according to any preceding claim, wherein the frit seal (320) contacts at least part of a first side surface of the electrically conductive line (400).
 14. A device according to any preceding claim, wherein a side surface of the conductive line (400) comprises a groove and the frit seal (320) comprises a portion partly received in the groove.
 15. A device according to Claim 15, wherein the frit seal (320) comprises a portion blocking a portion of the groove.
 16. A device according to any preceding claim, wherein the frit seal (320) comprises one or more materials selected from the group consisting of magnesium oxide (MgO), calcium oxide (CaO), barium oxide (BaO), lithium oxide (Li₂O), sodium oxide (Na₂O), potassium oxide (K₂O), boron oxide (B₂O₃), vanadium oxide (V₂O₅), zinc oxide (ZnO), tellurium oxide (TeO₂), aluminum oxide (Al₂O₃), silicon dioxide (SiO₂), lead oxide (PbO), tin oxide (SnO), phosphorous oxide (P₂O₅), ruthenium oxide (Ru₂O), rubidium oxide (Rb₂O), rhodium oxide (Rh₂O), ferrite oxide (Fe₂O₃), copper oxide (CuO), titanium oxide (TiO₂), tungsten oxide (WO₃), bismuth oxide (Bi₂O₃), antimony oxide (Sb₂O₃), lead-borate glass, tin-phosphate glass, vanadate glass, and borosilicate.
 17. A method of making an organic light-emitting display device, the method comprising:
 - providing a first substrate (200) and an electrically conductive line (400) formed on the first substrate (200);
 - providing a second substrate (300); and
 - interconnecting the first and second substrates (200, 300) with a frit seal (320) interposed therebetween;
 - wherein the electrically conductive line (400) comprises a portion overlapping with the frit seal (320), wherein the portion of the electrically conductive line comprises (400) a edge with geometrical structures such that the length along the edge with the geometrical structures is sub-

stantially longer than that without the geometrical structures;
 wherein the first geometrical structures comprise a protrusion **characterised in that** the protrusion comprises an extension from the protrusion, wherein the extension of the first geometrical structures extends in a direction substantially parallel to the portion of the electrically conductive line (400).

Patentansprüche

1. Organische Leuchtanzeigevorrichtung, umfassend:

ein erstes Substrat (200);
 ein zweites Substrat (300);
 eine Sinterdichtung (320), die das erste und das zweite Substrat (200, 300) miteinander verbindet; und
 eine elektrisch leitfähige Leitung (400), die auf dem ersten Substrat (200) ausgebildet ist und einen Abschnitt umfasst, der sich mit der Sinterdichtung (320) überschneidet, worin der Abschnitt der elektrisch leitfähigen Leitung (400) einen ersten Rand mit ersten geometrischen Strukturen umfasst, so dass die Länge entlang dem ersten Rand mit den ersten geometrischen Strukturen wesentlich länger ist, als sie ohne die ersten geometrischen Strukturen wäre;
 worin die ersten geometrischen Strukturen einen Vorsprung umfassen, **dadurch gekennzeichnet, dass** die erste geometrische Struktur eine Verlängerung des Vorsprungs umfasst, worin sich die Verlängerung der ersten geometrischen Strukturen in einer Richtung erstreckt, die im wesentlichen parallel zu dem Abschnitt der elektrisch leitfähigen Leitung (400) ist.

2. Vorrichtung nach Anspruch 1, worin das erste Substrat (200), das zweite Substrat (300) und die Sinterdichtung (320) einen eingeschlossenen Raum definieren, worin die elektrisch leitfähige Leitung (400) eine innerhalb des eingeschlossenen Raums angeordnete erste Schaltung und eine außerhalb des eingeschlossenen Raums angeordnete zweite Schaltung miteinander verbindet.

3. Vorrichtung nach Anspruch 1 oder 2, worin der Abschnitt ferner einen zweiten Rand umfasst, der im wesentlichen parallel zum ersten Rand ist, worin der zweite Rand zweite geometrische Strukturen umfasst, so dass die Länge entlang dem zweiten Rand mit den zweiten geometrischen Strukturen wesentlich länger ist, als sie ohne die zweiten geometrischen Strukturen wäre.

4. Vorrichtung nach Anspruch 3, worin die zweiten geo-

metrischen Strukturen mindestens eines von Folgendem umfassen: ein Vorsprung und eine Aussparung.

5. Vorrichtung nach einem der vorhergehenden Ansprüche, worin die ersten und/oder zweiten geometrischen Strukturen jeweils eine Vielzahl von Windungen entlang dem Rand bereitstellen.

6. Vorrichtung nach einem der vorhergehenden Ansprüche, worin die zweiten geometrischen Strukturen einen Vorsprung und eine Verlängerung des Vorsprungs umfassen, worin sich die Verlängerung der zweiten geometrischen Strukturen in einer Richtung erstreckt, die im wesentlichen parallel zu dem Abschnitt der elektrisch leitfähigen Leitung (400) ist.

7. Vorrichtung nach einem der vorhergehenden Ansprüche, worin die ersten und/oder zweiten geometrischen Strukturen jeweils eine Aussparung in der leitfähigen Leitung und einen sich von der Aussparung erstreckenden Kanal umfassen, worin sich der Kanal in einer Richtung erstreckt, die im wesentlichen parallel zu dem Abschnitt der elektrisch leitfähigen Leitung ist.

8. Vorrichtung nach einem der vorhergehenden Ansprüche, worin die elektrisch leitfähige Leitung (400) zwei oder mehr Schichten umfasst.

9. Vorrichtung nach Anspruch 8, worin die elektrisch leitfähige Leitung (400) eine Zwischenschicht umfasst, die zwischen zwei leitfähige Schichten geschichtet ist.

10. Vorrichtung nach Anspruch 9, worin jede der zwei leitfähigen Schichten ein gemeinsames Material umfasst.

11. Vorrichtung nach einem der vorhergehenden Ansprüche, worin die elektrisch leitfähige Leitung eine geschichtete Struktur aus Titan (Ti)/Aluminium (Al)/Titan (Ti) oder Molybdän (Mo)/Aluminium (Al)/Molybdän (Mo) umfasst.

12. Vorrichtung nach einem der vorhergehenden Ansprüche, worin die elektrisch leitfähige Leitung (400) keine Durchgangslöcher darin umfasst.

13. Vorrichtung nach einem der vorhergehenden Ansprüche, worin die Sinterdichtung (320) mindestens einen Teil einer ersten seitlichen Oberfläche der elektrisch leitfähigen Leitung (400) berührt.

14. Vorrichtung nach einem der vorhergehenden Ansprüche, worin eine seitliche Oberfläche der elektrisch leitfähigen Leitung (400) eine Nut umfasst und die Sinterdichtung (320) einen Abschnitt umfasst,

der teilweise in der Nut aufgenommen wird.

15. Vorrichtung nach Anspruch 15, worin die Sinterdichtung (320) einen Abschnitt umfasst, der einen Abschnitt der Nut sperrt.

16. Vorrichtung nach einem der vorhergehenden Ansprüche, worin die Sinterdichtung (320) ein oder mehrere Materialien umfasst, die aus der Gruppe ausgewählt werden, die aus Folgendem besteht: Magnesiumoxid (MgO), Kalziumoxid (CaO), Bariumoxid (BaO), Lithiumoxid (Li₂O), Natriumoxid (Na₂O), Kaliumoxid (K₂O), Boroxid (B₂O₃), Vanadiumoxid (V₂O₅), Zinkoxid (ZnO), Telluroxid (TeO₂), Aluminiumoxid (Al₂O₃), Siliziumdioxid (SiO₂), Bleioxid (PbO), Zinnoxid (SnO), Phosphorpentoxid (P₂O₅), Rutheniumoxid (Ru₂O), Rubidiumoxid (Rb₂O), Rhodiumoxid (Rh₂O), Eisen(III)-oxid (Fe₂O₃), Kupferoxid (CuO), Titanoxid (TiO₂), Wolframoxid (WO₃), Bismutoxid (Bi₂O₃), Antimonoxid (Sb₂O₃), Bleiboratglas, Zinnphosphatglas, Vanadatglas und Borosilikat.

17. Verfahren zur Herstellung einer organischen Leuchtanzeigevorrichtung, wobei das Verfahren umfasst:

Bereitstellen eines ersten Substrats (200) und einer auf dem ersten Substrat (200) ausgebildeten elektrisch leitfähigen Leitung (400);
 Bereitstellen eines zweiten Substrats (300); und miteinander Verbinden des ersten und des zweiten Substrats (200, 300) mit einer dazwischengeschichteten Sinterdichtung (320);
 worin die elektrisch leitfähigen Leitung (400) einen Abschnitt umfasst, der sich mit der Sinterdichtung (320) überschneidet, worin der Abschnitt der elektrisch leitfähigen Leitung (400) einen Rand mit geometrischen Strukturen umfasst, so dass die Länge entlang dem Rand mit den geometrischen Strukturen wesentlich länger als die ohne die geometrischen Strukturen ist;
 worin die geometrischen Strukturen einen Vorsprung umfassen, **dadurch gekennzeichnet, dass** der Vorsprung eine Verlängerung des Vorsprungs umfasst, worin sich die Verlängerung der geometrischen Strukturen in einer Richtung erstreckt, die im wesentlichen parallel zu dem Abschnitt der elektrisch leitfähigen Leitung (400) ist.

Revendications

1. Dispositif d'affichage électroluminescent organique comprenant :

un premier substrat (200) ;

un deuxième substrat (300) ;

un joint de frit interconnectant (320) les premier et deuxième substrats (200, 300) ; et
 une ligne électriquement conductrice (400) formée sur le premier substrat (200) et comprenant une partie de superposition avec le joint de frit (320), dans lequel la partie de la ligne électriquement conductrice (400) comprend un premier bord avec des premières structures géométriques de sorte que la longueur le long du premier bord avec les premières structures géométriques est sensiblement plus longue qu'elle le serait sans les premières structures géométriques ;

dans lequel les premières structures géométriques comprennent une protubérance, **caractérisé en ce que** la première structure géométrique comprend une extension de la protubérance, dans lequel l'extension des premières structures géométriques s'étend dans une direction sensiblement parallèle à la partie de la ligne électriquement conductrice (400).

2. Dispositif selon la revendication 1, dans lequel le premier substrat (200), le deuxième substrat (300) et le joint de frit (320) définissent un espace clos, dans lequel la ligne électriquement conductrice (400) interconnecte un premier circuit situé dans l'espace clos et un deuxième circuit situé à l'extérieur de l'espace clos.

3. Dispositif selon la revendication 1 ou 2, dans lequel la partie comprend en outre un deuxième bord généralement parallèle au premier bord, dans lequel le deuxième bord comprend des deuxièmes structures géométriques de sorte que la longueur le long du deuxième bord avec les deuxièmes structures géométriques est sensiblement plus longue qu'elle le serait sans les deuxièmes structures géométriques.

4. Dispositif selon la revendication 3, dans lequel les deuxièmes structures géométriques comprennent au moins l'un d'une protubérance et d'un évidement.

5. Dispositif selon l'une quelconque des revendications précédentes, dans lequel les premières et/ou les deuxièmes structures géométriques réalisent respectivement une pluralité de tours le long du bord.

6. Dispositif selon l'une quelconque des revendications précédentes, dans lequel les deuxièmes structures géométriques comprennent une protubérance et une extension de la protubérance, dans lequel l'extension de la deuxième structure géométriques s'étend dans une direction sensiblement parallèle à la partie de la ligne électriquement conductrice (400).

7. Dispositif selon l'une quelconque des revendications précédentes, dans lequel les premières et/ou deuxièmes structures géométriques comprennent respectivement un évidement dans la ligne conductrice et un canal s'étendant de l'évidement, dans lequel le canal s'étend dans une direction sensiblement parallèle à la partie de la ligne électriquement conductrice. 5
8. Dispositif selon l'une quelconque des revendications précédentes, dans lequel la ligne électriquement conductrice (400) comprend deux couches ou plus. 10
9. Dispositif selon la revendication 8, dans lequel la ligne électriquement conductrice (400) comprend une couche interposée qui est interposée entre deux couches conductrices. 15
10. Dispositif selon la revendication 9, dans lequel chacune des deux couches conductrices comprend un matériau commun, 20
11. Dispositif selon l'une quelconque des revendications précédentes, dans lequel la ligne électriquement conductrice comprend une structure en couches de titane (Ti)/aluminium (Al)/titane (Ti) ou de molybdène (Mo)/aluminium (Al)/molybdène (Mo). 25
12. Dispositif selon l'une quelconque des revendications précédentes, dans lequel la ligne électriquement conductrice (400) ne comprend pas de trous traversants dans celle-ci. 30
13. Dispositif selon l'une quelconque des revendications précédentes, dans lequel le joint de frit (320) est en contact avec au moins une partie d'une première surface latérale de la ligne électriquement conductrice (400). 35
14. Dispositif selon l'une quelconque des revendications précédentes, dans lequel une surface latérale de la ligne conductrice (400) comprend une rainure et le joint de frit (320) comprend une partie reçue partiellement dans la rainure. 40
15. Dispositif selon la revendication 15, dans lequel le joint de frit (320) comprend une partie bloquant une partie de la rainure. 45
16. Dispositif selon l'une quelconque des revendications précédentes, dans lequel le joint de frit (320) comprend un ou plusieurs matériaux sélectionnés dans le groupe consistant en l'oxyde de magnésium (MgO), l'oxyde de calcium (CaO), l'oxyde de baryum (BaO), l'oxyde de lithium (Li₂O), l'oxyde de sodium (Na₂O), l'oxyde de potassium (K₂O), l'oxyde de bore (B₂O₃), l'oxyde de vanadium (V₂O₅), l'oxyde de zinc (ZnO), l'oxyde de tellurium (TeO₂), l'oxyde d'aluminium (Al₂O₃), le dioxyde de silicium (SiO₂), l'oxyde de plomb (PbO), l'oxyde d'étain (SnO), l'oxyde de phosphore (P₂O₅), l'oxyde de ruthénium (Ru₂O), l'oxyde de rubidium (Rb₂O), l'oxyde de rhodium (Rh₂O), l'oxyde de ferrite (Fe₂O₃), l'oxyde de cuivre (CuO), l'oxyde de titane (TiO₂), l'oxyde de tungstène (WO₃), l'oxyde de bismuth (Bi₂O₃), l'oxyde d'antimoine (Sb₂O₃), le verre de plomb-borate, le verre d'étain-phosphate, le verre de vanadate et le borosilicate. 50
17. Procédé de fabrication d'un dispositif d'affichage électroluminescent organique, le procédé comprenant : 55
- la fourniture d'un premier substrat (200) et d'une ligne électriquement conductrice (400) formée sur le premier substrat (200) ;
- la fourniture d'un deuxième substrat (300) ; et
- l'interconnexion des premier et deuxième substrats (200, 300) avec un joint de frit (320) interposé entre ceux-ci ;
- dans lequel la ligne électriquement conductrice (400) comprend une partie de superposition avec le joint de frit (320), dans lequel la partie de la ligne électriquement conductrice (400) comprend un bord avec des structures géométriques de sorte que la longueur le long du bord avec les structures géométriques est sensiblement plus longue qu'elle le serait sans les structures géométriques ;
- dans lequel les premières structures géométriques comprennent une protubérance, **caractérisé en ce que** la protubérance comprend une extension de la protubérance, dans lequel l'extension des premières structures géométriques s'étend dans une direction sensiblement parallèle à la partie de la ligne électriquement conductrice (400).

FIG. 1

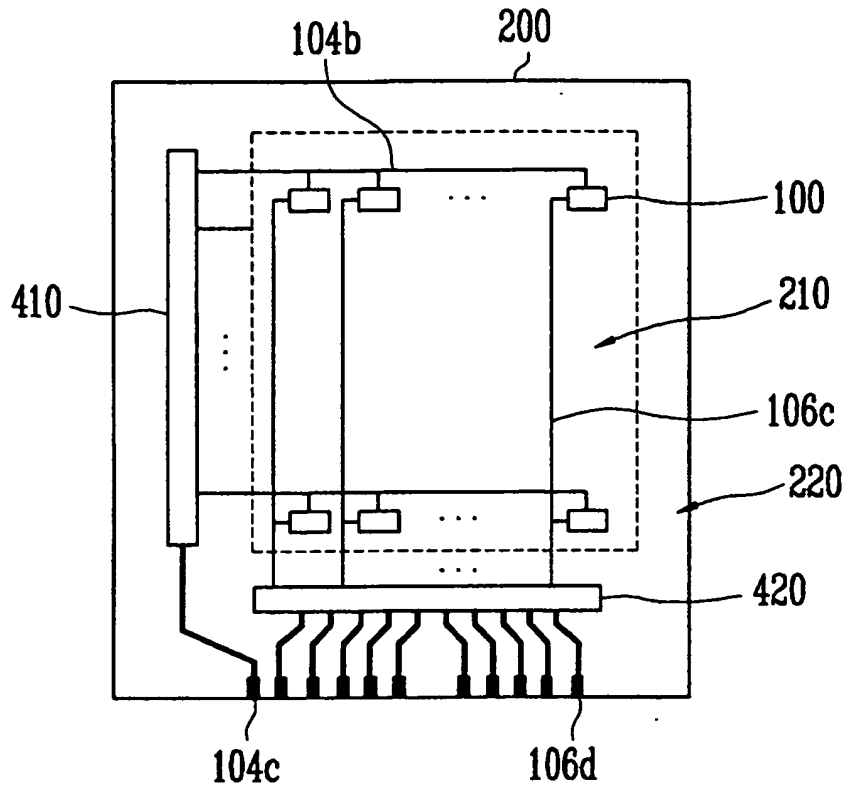

FIG. 2A

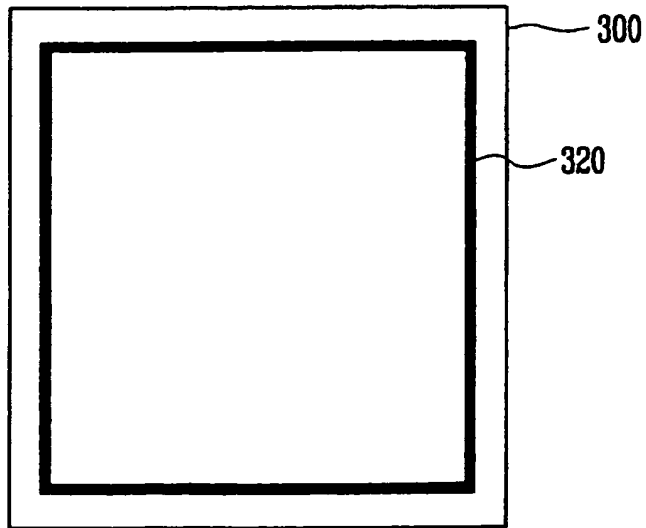

FIG. 2B

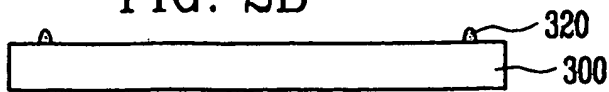

FIG. 3

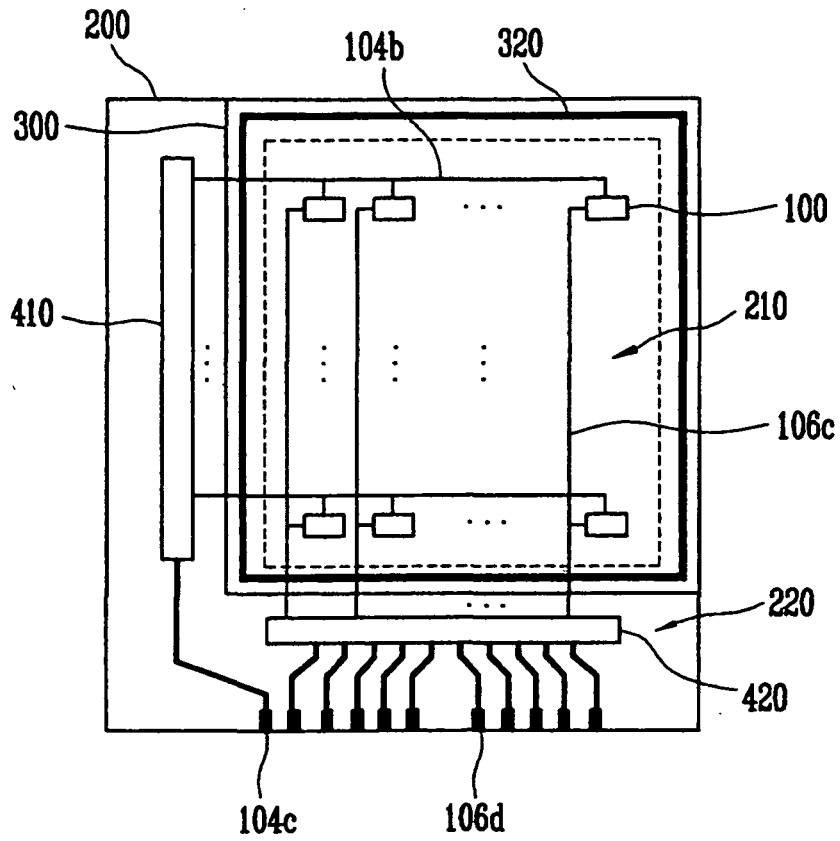

FIG. 4

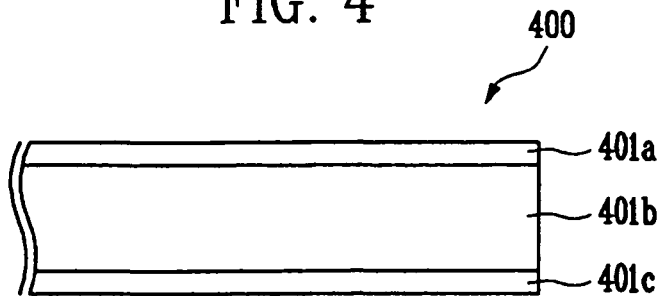

FIG. 5A

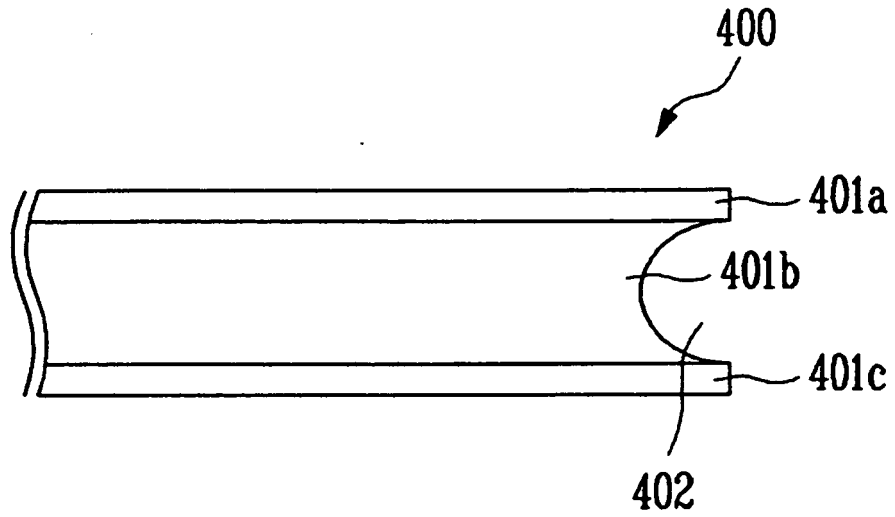

FIG. 5B

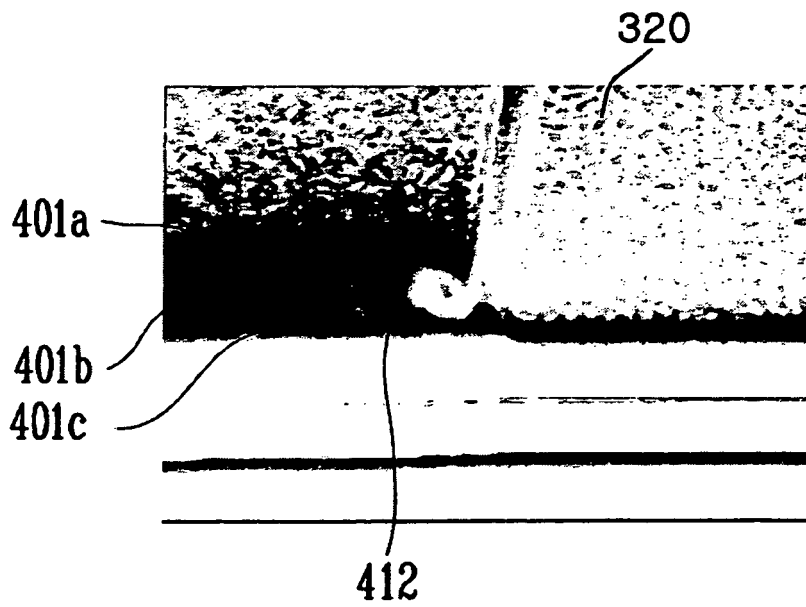

FIG. 6

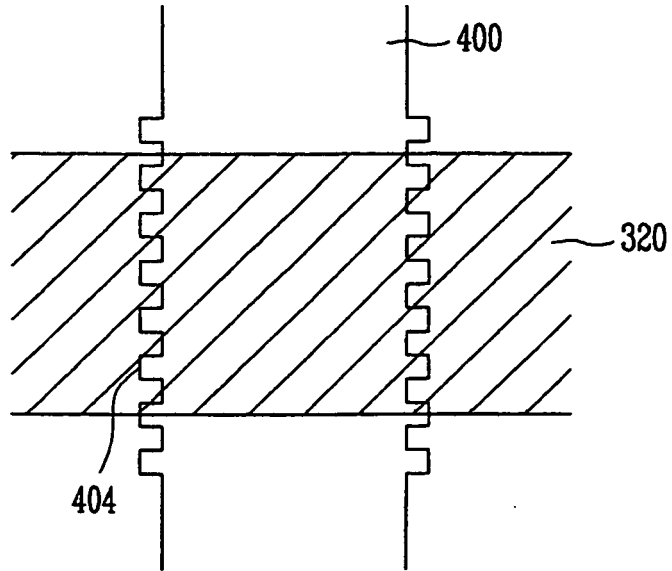

FIG. 7A

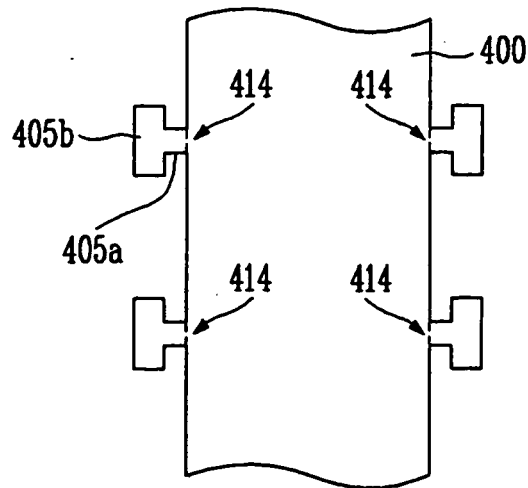

FIG. 7B

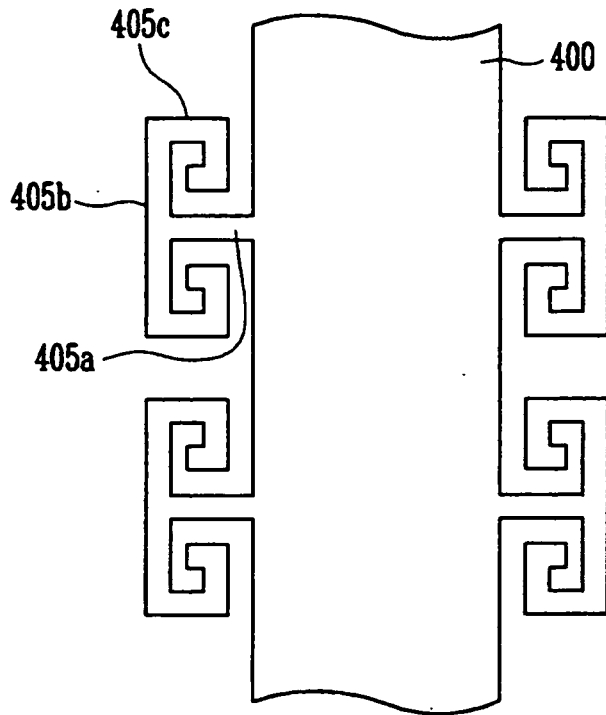

FIG. 8

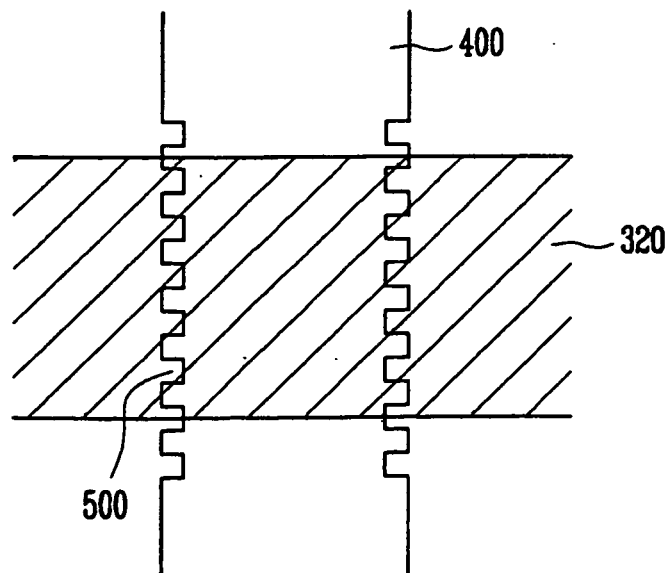

FIG. 9A

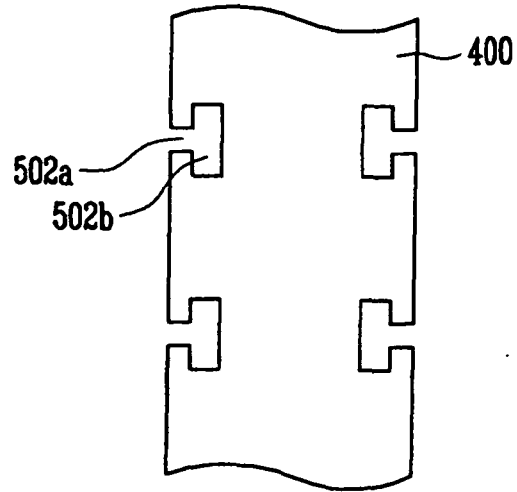

FIG. 9B

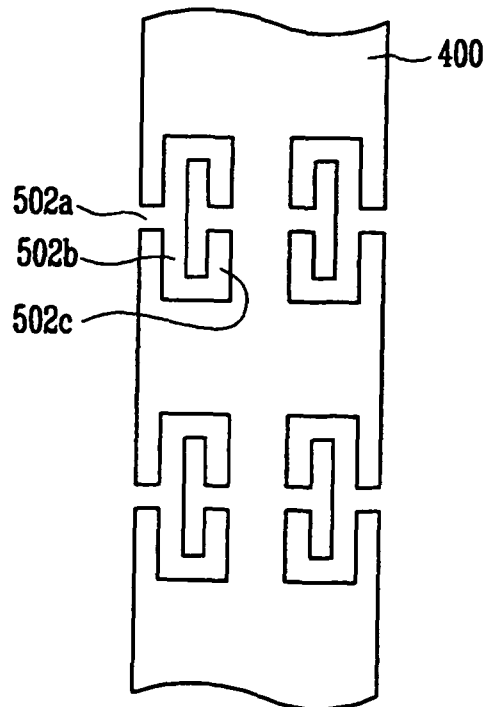

FIG. 10A

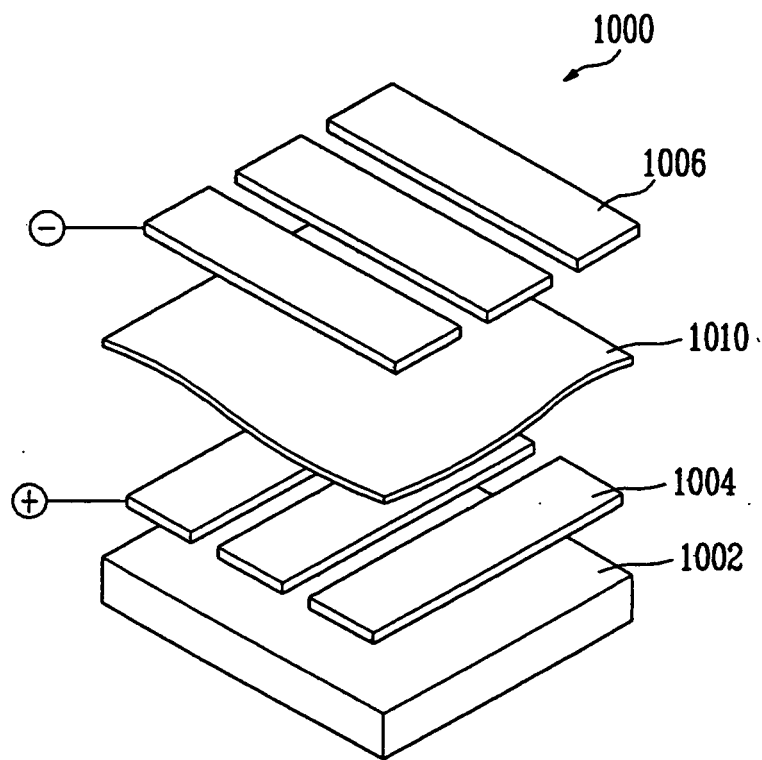

FIG. 10B

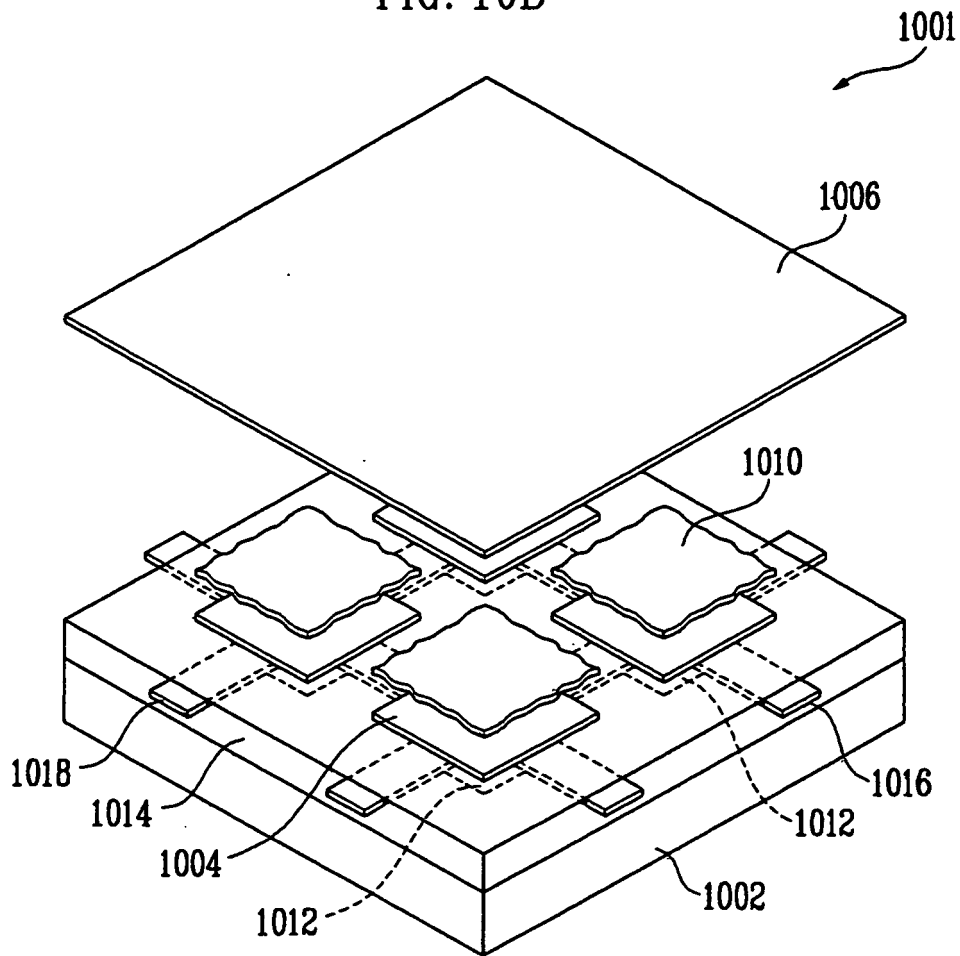

FIG. 10C

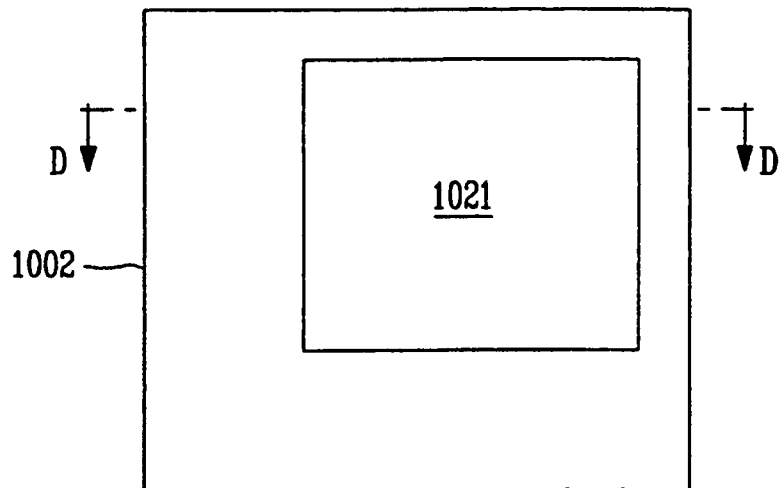

FIG. 10D

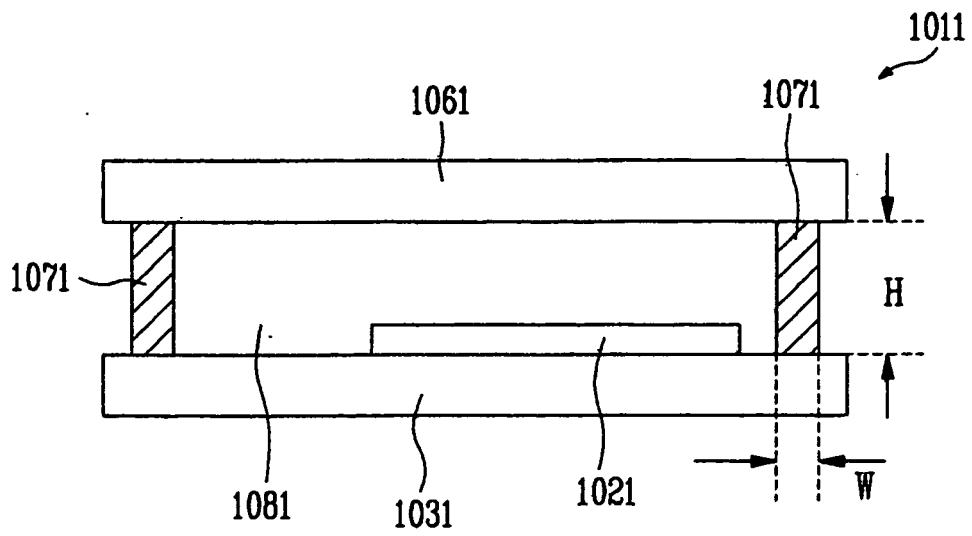
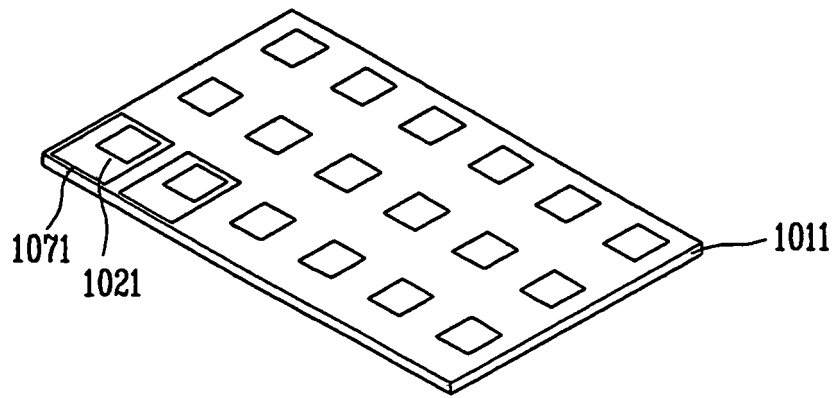

FIG. 10E



REFERENCES CITED IN THE DESCRIPTION

This list of references cited by the applicant is for the reader's convenience only. It does not form part of the European patent document. Even though great care has been taken in compiling the references, errors or omissions cannot be excluded and the EPO disclaims all liability in this regard.

Patent documents cited in the description

- US 6998776 B [0004]
- EP 0971564 A [0005]

专利名称(译)	有机发光显示装置		
公开(公告)号	EP1814183B1	公开(公告)日	2013-11-13
申请号	EP2007250337	申请日	2007-01-26
[标]申请(专利权)人(译)	三星斯笛爱股份有限公司		
申请(专利权)人(译)	三星SDI CO., LTD.		
当前申请(专利权)人(译)	三星DISPLAY CO., LTD.		
[标]发明人	KWAK WON KYU		
发明人	KWAK, WON-KYU		
IPC分类号	H01L51/52 H01L27/32		
CPC分类号	H01L27/3276 H01L27/3288 H01L51/5246		
优先权	1020060016187 2006-02-20 KR 1020060008461 2006-01-26 KR		
其他公开文献	EP1814183A2 EP1814183A3		
外部链接	Espacenet		

摘要(译)

一种有机发光显示装置，适于防止氧气，湿气等的渗入。所述有机发光显示装置包括：第一基板，包括形成像素的像素区域和除所述像素区域外的非像素区域；第二基板，在包括像素区域的一个区域中与第一基板相对并接合；玻璃料位于非像素区域和第二基板之间，以粘合第一基板和第二基板；形成在第一基板上的至少一条金属线与部分玻璃料重叠。金属线的侧面在重叠区域中设有几何结构，以避免在玻璃料和金属线之间形成通道。

