

(19)



(11)

EP 3 544 075 A1

(12)

EUROPEAN PATENT APPLICATION

(43) Date of publication:
25.09.2019 Bulletin 2019/39

(51) Int Cl.:
H01L 51/54 (2006.01) C07F 15/00 (2006.01)

(21) Application number: **19154092.1**

(22) Date of filing: **29.01.2019**

(84) Designated Contracting States:
AL AT BE BG CH CY CZ DE DK EE ES FI FR GB GR HR HU IE IS IT LI LT LU LV MC MK MT NL NO PL PT RO RS SE SI SK SM TR
Designated Extension States:
BA ME
Designated Validation States:
KH MA MD TN

- **PARK, Junha**
Gyeonggi-do (KR)
- **AHN, Heechoon**
Gyeonggi-do (KR)
- **LEE, Hyoyoung**
Gyeonggi-do (KR)
- **JEON, Mina**
Gyeonggi-do (KR)
- **JUN, Mieun**
Gyeonggi-do (KR)
- **HAN, Junghoon**
Gyeonggi-do (KR)
- **KIM, Youngkook**
Gyeonggi-do (KR)
- **HWANG, Seokhwan**
Gyeonggi-do (KR)

(30) Priority: **22.03.2018 KR 20180033483**

(71) Applicant: **Samsung Display Co., Ltd.**
Gyeonggi-Do (KR)

- (72) Inventors:
- **SIM, Munki**
Gyeonggi-do (KR)
 - **KO, Soobyung**
Gyeonggi-do (KR)
 - **KIM, Sungbum**
Gyeonggi-do (KR)

(74) Representative: **Shearman, James Ward**
Marks & Clerk LLP
15 Fetter Lane
London EC4A 1BW (GB)

(54) **ORGANOMETALLIC COMPOUND, ORGANIC LIGHT-EMITTING DEVICE INCLUDING THE SAME, AND ORGANIC LIGHT-EMITTING APPARATUS INCLUDING THE ORGANIC LIGHT-EMITTING DEVICE**

(57) Provided are an organometallic compound, an organic light-emitting device including the organometallic compound, and an electronic apparatus including the organic light-emitting device. The organic light-emitting device includes: a first electrode; a second electrode facing the first electrode; and an organic layer between the first electrode and the second electrode and including an emission layer, wherein the organic layer comprises at least one of the organometallic compound represented by Formula 1.

EP 3 544 075 A1

<Formula 1>

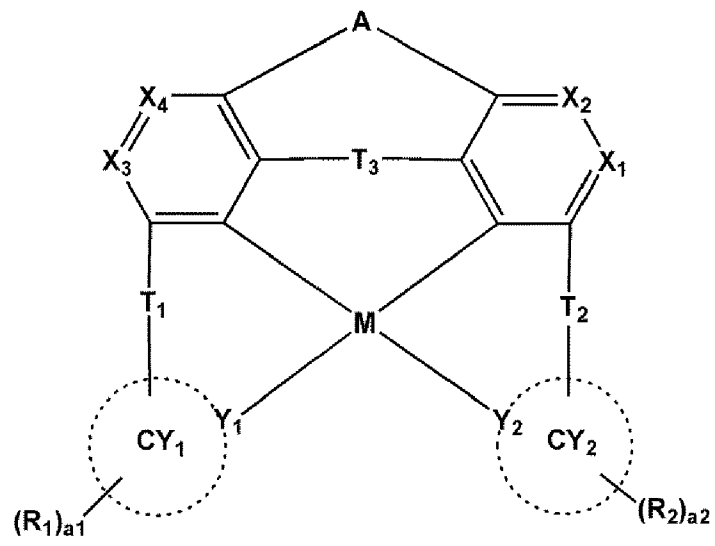

FIG. 1

10

190
150
110

Description

BACKGROUND

5 1. Field

[0001] One or more embodiments relate to an organometallic compound, an organic light-emitting device including the same, and an organic light-emitting apparatus including the organic light-emitting device.

10 2. Description of the Related Art

[0002] Organic light-emitting devices are self-emission devices that produce full-color images, and also have wide viewing angles, high contrast ratios, short response times, and excellent characteristics in terms of brightness, driving voltage, and response speed, as compared to other devices in the art.

15 [0003] An example of such organic light-emitting devices may include a first electrode disposed on a substrate, and a hole transport region, an emission layer, an electron transport region, and a second electrode, which are sequentially disposed on the first electrode. Holes provided from the first electrode may move toward the emission layer through the hole transport region, and electrons provided from the second electrode may move toward the emission layer through the electron transport region. Carriers, such as holes and electrons, recombine in the emission layer to produce excitons.
20 These excitons transit (e.g., transition or relax) from an excited state to a ground state, thereby generating light.

SUMMARY

25 [0004] Aspects of embodiments of the present disclosure provide a novel organometallic compound and an organic light-emitting device including the same.

[0005] Additional aspects of embodiments will be set forth in part in the description which follows and, in part, will be apparent from the description, or may be learned by practice of the presented embodiments.

[0006] An aspect of an embodiment provides an organometallic compound represented by Formula 1:

30

Formula 1

35

40

45

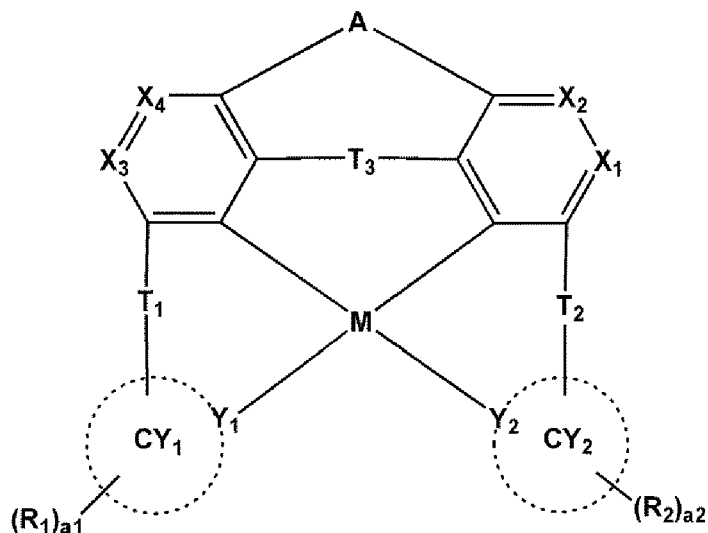

50 [0007] In Formula 1,

M is selected from transition metals,

CY₁ and CY₂ are each independently a C₅-C₆₀ carbocyclic group or a C₁-C₆₀ heterocyclic group,

X₁ is C(R₁₁) or N, X₂ is C(R₁₂) or N, X₃ is C(R₁₃) or N, and X₄ is C(R₁₄) or N,

55 Y₁ and Y₂ are each independently C or N,

a bond between Y₁ and M and a bond between Y₂ and M are each a coordinate bond,

A is selected from O, S, N(R₃), C(R₃)(R₄), and Si(R₃)(R₄),

T₁ to T₃ are each independently selected from a single bond, *-O-*, *-S-*, *-C(R₅)(R₆)-*, *-C(R₅)=*, *=C(R₅)-*, *-

$C(R_5)=C(R_6)^{-*}$, $^*C(=O)^{-*}$, $^*C(=S)^{-*}$, $^*C\equiv C^*$, $^*B(R_5)^{-*}$, $^*N(R_5)^{-*}$, $^*P(R_5)^{-*}$, $^*Si(R_5)(R_6)^{-*}$, and $^*Ge(R_5)(R_6)^{-*}$,
 R_1 to R_6 and R_{11} to R_{14} are each independently be selected from hydrogen, deuterium, -F, -Cl, -Br, -I, a hydroxyl
 group, a cyano group, a nitro group, an amidino group, a hydrazino group, a hydrazono group, a substituted or
 unsubstituted C_1 - C_{60} alkyl group, a substituted or unsubstituted C_2 - C_{60} alkenyl group, a substituted or unsubstituted
 C_2 - C_{60} alkynyl group, a substituted or unsubstituted C_1 - C_{60} alkoxy group, a substituted or unsubstituted C_3 - C_{10}
 cycloalkyl group, a substituted or unsubstituted C_1 - C_{10} heterocycloalkyl group, a substituted or unsubstituted C_3 - C_{10}
 cycloalkenyl group, a substituted or unsubstituted C_1 - C_{10} heterocycloalkenyl group, a substituted or unsubstituted
 C_6 - C_{60} aryl group, a substituted or unsubstituted C_6 - C_{60} aryloxy group, a substituted or unsubstituted C_6 - C_{60} arylthio
 group, a substituted or unsubstituted C_1 - C_{60} heteroaryl group, a substituted or unsubstituted monovalent non-
 aromatic condensed polycyclic group, a substituted or unsubstituted monovalent non-aromatic condensed hetero-
 polycyclic group, $-Si(Q_1)(Q_2)(Q_3)$, $-N(Q_1)(Q_2)$, $-B(Q_1)(Q_2)$, $-P(Q_1)(Q_2)$, $-C(=O)(Q_1)$, $-S(=O)_2(Q_1)$, and
 $-P(=O)(Q_1)(Q_2)$, wherein two neighboring groups selected from R_1 to R_6 are optionally linked to form a substituted
 or unsubstituted C_5 - C_{60} carbocyclic group or a substituted or unsubstituted C_1 - C_{60} heterocyclic group,

a_1 and a_2 are each independently an integer of 1 to 5, wherein, when a_1 is two or more, two or more $R_1(s)$ are
 identical to or different from each other, and when a_2 is two or more, two or more $R_2(s)$ are identical to or different
 from each other,

at least one substituent of the substituted C_5 - C_{60} carbocyclic group, the substituted C_1 - C_{60} heterocyclic group, the
 substituted C_1 - C_{60} alkyl group, the substituted C_2 - C_{60} alkenyl group, the substituted C_2 - C_{60} alkynyl group, the
 substituted C_1 - C_{60} alkoxy group, the substituted C_3 - C_{10} cycloalkyl group, the substituted C_1 - C_{10} heterocycloalkyl
 group, the substituted C_3 - C_{10} cycloalkenyl group, the substituted C_1 - C_{10} heterocycloalkenyl group, the substituted
 C_6 - C_{60} aryl group, the substituted C_6 - C_{60} aryloxy group, the substituted C_6 - C_{60} arylthio group, the substituted C_1 - C_{60}
 heteroaryl group, the substituted monovalent non-aromatic condensed polycyclic group, and the substituted mono-
 valent non-aromatic condensed heteropolycyclic group is selected from:

deuterium (-D), -F, -Cl, -Br, -I, a hydroxyl group, a cyano group, a nitro group, an amidino group, a hydrazino group,
 a hydrazono group, a C_1 - C_{60} alkyl group, a C_2 - C_{60} alkenyl group, a C_2 - C_{60} alkynyl group, and a C_1 - C_{60} alkoxy group;
 a C_1 - C_{60} alkyl group, a C_2 - C_{60} alkenyl group, a C_2 - C_{60} alkynyl group, and a C_1 - C_{60} alkoxy group, each substituted
 with at least one selected from deuterium, -F, -Cl, -Br, -I, a hydroxyl group, a cyano group, a nitro group, an amidino
 group, a hydrazino group, a hydrazono group, a C_3 - C_{10} cycloalkyl group, a C_1 - C_{10} heterocycloalkyl group, a C_3 - C_{10}
 cycloalkenyl group, a C_1 - C_{10} heterocycloalkenyl group, a C_6 - C_{60} aryl group, a C_6 - C_{60} aryloxy group, a C_6 - C_{60}
 arylthio group, a C_1 - C_{60} heteroaryl group, a monovalent non-aromatic condensed polycyclic group, a monovalent
 non-aromatic condensed heteropolycyclic group, $-Si(Q_{11})(Q_{12})(Q_{13})$, $-N(Q_{11})(Q_{12})$, $-B(Q_{11})(Q_{12})$, $-C(=O)(Q_{11})$,
 $-S(=O)_2(Q_{11})$, and $-P(=O)(Q_{11})(Q_{12})$;

a C_3 - C_{10} cycloalkyl group, a C_1 - C_{10} heterocycloalkyl group, a C_3 - C_{10} cycloalkenyl group, a C_1 - C_{10} heterocycloalkenyl
 group, a C_6 - C_{60} aryl group, a C_6 - C_{60} aryloxy group, a C_6 - C_{60} arylthio group, a C_1 - C_{60} heteroaryl group, a monovalent
 non-aromatic condensed polycyclic group, and a monovalent non-aromatic condensed heteropolycyclic group;

a C_3 - C_{10} cycloalkyl group, a C_1 - C_{10} heterocycloalkyl group, a C_3 - C_{10} cycloalkenyl group, a C_1 - C_{10} heterocycloalkenyl
 group, a C_6 - C_{60} aryl group, a C_6 - C_{60} aryloxy group, a C_6 - C_{60} arylthio group, a C_1 - C_{60} heteroaryl group, a monovalent
 non-aromatic condensed polycyclic group, and a monovalent non-aromatic condensed heteropolycyclic group, each
 substituted with at least one selected from deuterium, -F, -Cl, -Br, -I, a hydroxyl group, a cyano group, a nitro group,
 an amidino group, a hydrazino group, a hydrazono group, a C_1 - C_{60} alkyl group, a C_2 - C_{60} alkenyl group, a C_2 - C_{60}
 alkynyl group, a C_1 - C_{60} alkoxy group, a C_3 - C_{10} cycloalkyl group, a C_1 - C_{10} heterocycloalkyl group, a C_3 - C_{10} cy-
 cloalkenyl group, a C_1 - C_{10} heterocycloalkenyl group, a C_6 - C_{60} aryl group, a C_6 - C_{60} aryloxy group, a C_6 - C_{60} arylthio
 group, a C_1 - C_{60} heteroaryl group, a monovalent non-aromatic condensed polycyclic group, a monovalent non-
 aromatic condensed heteropolycyclic group, $-Si(Q_{21})(Q_{22})(Q_{23})$, $-N(Q_{21})(Q_{22})$, $-B(Q_{21})(Q_{22})$, $-C(=O)(Q_{21})$,
 $-S(=O)_2(Q_{21})$, and $-P(=O)(Q_{21})(Q_{22})$; and

$-Si(Q_{31})(Q_{32})(Q_{33})$, $-N(Q_{31})(Q_{32})$, $-B(Q_{31})(Q_{32})$, $-C(=O)(Q_{31})$, $-S(=O)_2(Q_{31})$, and $-P(=O)(Q_{31})(Q_{32})$,

Q_1 to Q_3 , Q_{11} to Q_{13} , Q_{21} to Q_{23} , and Q_{31} to Q_{33} are each independently selected from hydrogen, deuterium, -F,
 -Cl, -Br, -I, a hydroxyl group, a cyano group, a nitro group, an amidino group, a hydrazino group, a hydrazono group,
 a C_1 - C_{60} alkyl group, a C_2 - C_{60} alkenyl group, a C_2 - C_{60} alkynyl group, a C_1 - C_{60} alkoxy group, a C_3 - C_{10} cycloalkyl
 group, a C_1 - C_{10} heterocycloalkyl group, a C_3 - C_{10} cycloalkenyl group, a C_1 - C_{10} heterocycloalkenyl group, a C_6 - C_{60}
 aryl group, a C_1 - C_{60} heteroaryl group, a monovalent non-aromatic condensed polycyclic group, a monovalent non-
 aromatic condensed heteropolycyclic group, a biphenyl group, and a terphenyl group, and

* and *' each indicate a binding site to a neighboring atom.

[0008] Another aspect of an embodiment provides an organic light-emitting device including: a first electrode; a second
 electrode facing the first electrode; and an organic layer between the first electrode and the second electrode and
 including an emission layer, wherein the organic layer includes at least one of the organometallic compound.

[0009] Another aspect of an embodiment provides an electronic apparatus including a thin film transistor and the

organic light-emitting device, wherein the thin film transistor includes a source electrode, a drain electrode, an active layer, and a gate electrode, and the first electrode of the organic light-emitting device is electrically coupled to (e.g., electrically connected to) one of the source electrode and the drain electrode of the thin film transistor.

5 BRIEF DESCRIPTION OF THE DRAWINGS

[0010] These and/or other aspects of embodiments will become apparent and more readily appreciated from the following description of the embodiments, taken in conjunction with the accompanying drawings in which:

- 10 FIG. 1 is a schematic view of an organic light-emitting device according to an embodiment;
 FIG. 2 is a schematic view of an organic light-emitting device according to an embodiment;
 FIG. 3 is a schematic view of an organic light-emitting device according to an embodiment; and
 FIG. 4 is a schematic view of an organic light-emitting device according to an embodiment.

15 DETAILED DESCRIPTION

[0011] Reference will now be made in more detail to embodiments, examples of which are illustrated in the accompanying drawings, wherein like reference numerals refer to like elements throughout. In this regard, the present embodiments may have different forms and should not be construed as being limited to the descriptions set forth herein. Accordingly, the embodiments are merely described below, by referring to the figures, to explain aspects of embodiments of the present description. As used herein, the term "and/or" includes any and all combinations of one or more of the associated listed items. Expressions such as "at least one of," when preceding a list of elements, modify the entire list of elements and do not modify the individual elements of the list.

[0012] An organometallic compound according to an embodiment is represented by Formula 1 below:

25

Formula 1

30

35

40

45

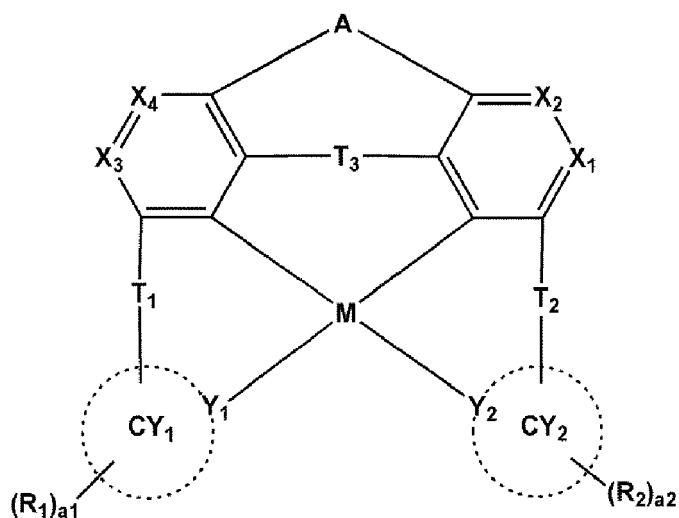

[0013] In Formula 1, M is selected from transition metals.

50

[0014] In one embodiment, M may be selected from platinum (Pt), palladium (Pd), copper (Cu), silver (Ag), gold (Au), rhodium (Rh), iridium (Ir), ruthenium (Ru), and osmium (Os), but embodiments of the present disclosure are not limited thereto.

[0015] For example, M may be selected from platinum (Pt), palladium (Pd), copper (Cu), silver (Ag), and gold (Au). For example, M may be selected from platinum (Pt) and palladium (Pd). For example, M may be platinum (Pt).

55

[0016] In Formula 1, CY₁ and CY₂ are each independently a C₅-C₆₀ carbocyclic group or a C₁-C₆₀ heterocyclic group. For example, CY₁ and CY₂ may each independently be a C₅-C₃₀ carbocyclic group or a C₁-C₂₀ heterocyclic group. For example, CY₁ and CY₂ may each independently be a C₅-C₂₀ carbocyclic group or a C₁-C₁₀ heterocyclic group. For example, CY₁ and CY₂ may each independently be a C₅-C₁₀ carbocyclic group or a C₁-C₁₀ heterocyclic group. For example, CY₁ and CY₂ may each independently be a C₆-C₁₀ carbocyclic group or a C₁-C₁₀ heterocyclic group.

[0017] In one embodiment, CY_1 and CY_2 may each independently be selected from:

a 5-membered carbocyclic group, a 6-membered carbocyclic group, a 5-membered heterocyclic group, and a 6-membered heterocyclic group; and

a condensed ring in which two or more groups selected from a 5-membered carbocyclic group, a 6-membered carbocyclic group, a 5-membered heterocyclic group, and a 6-membered heterocyclic group are condensed; but embodiments of the present disclosure are not limited thereto.

[0018] For example, CY_1 and CY_2 may each independently be selected from a benzene group, a pyridine group, a pyrimidine group, a pyridazine group, a pyrazine group, a triazine group, a tetrazine group, a pyrrole group, an imidazole group, a triazole group, an indole group, an isoindole group, an indolizine group, a pyrrolopyridine group, a pyrrolopyrimidine group, a pyrrolopyrazine group, a pyrrolopyridazine group, a pyrrolotriazine group, a pyrrolotetrazine group, a quinoline group, an isoquinoline group, a quinoxaline group, and a quinazoline group.

[0019] In one embodiment, in Formula 1, a moiety represented by

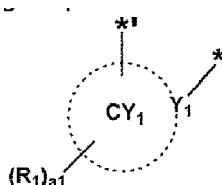

may be selected from groups represented by Formulae 3-1 to 3-40, but embodiments of the present disclosure are not limited thereto:

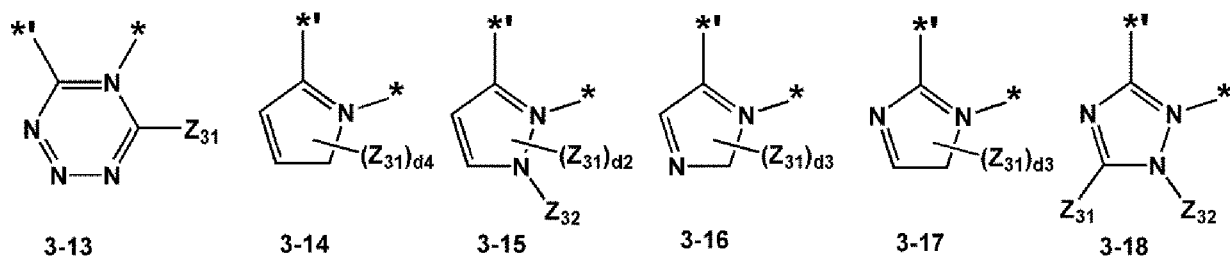
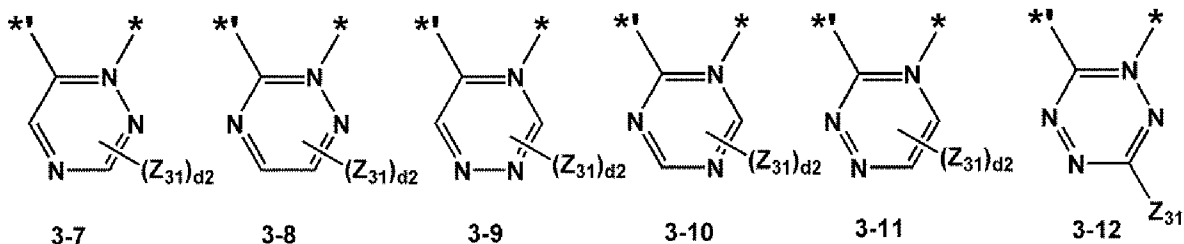
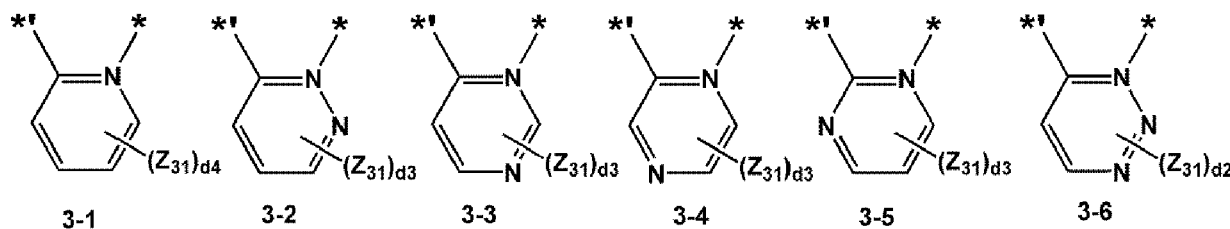

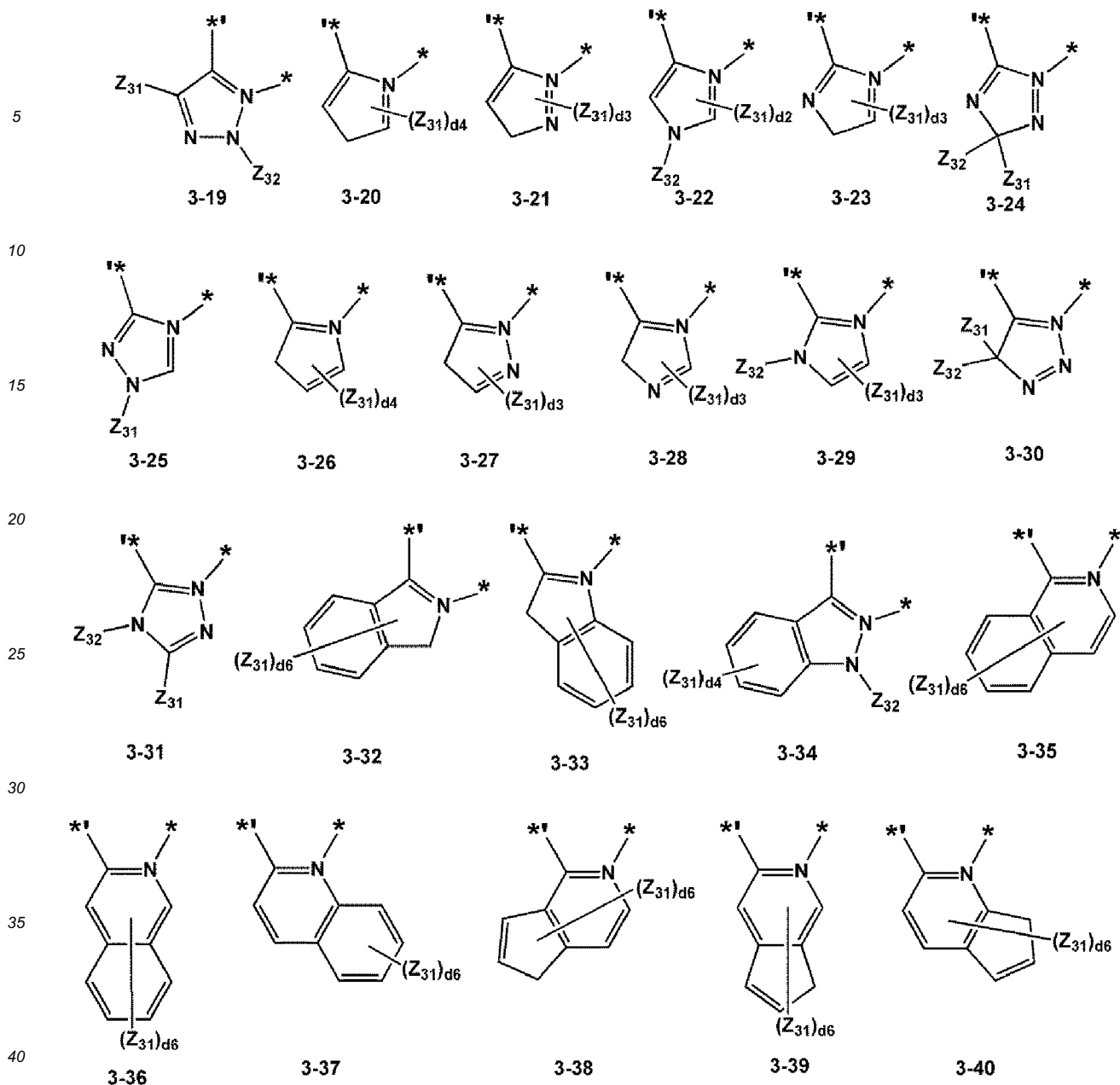

Z_{31} to Z_{32} are each independently selected from hydrogen, deuterium, -F, -Cl, -Br, -I, a hydroxyl group, a cyano group, a nitro group, an amidino group, a hydrazino group, a hydrazono group, a C_1 - C_{20} (e.g. C_1 - C_{10}) alkyl group, a C_2 - C_{20} (e.g. C_2 - C_{10}) alkenyl group, a C_2 - C_{20} (e.g. C_2 - C_{10}) alkynyl group, a C_1 - C_{20} (e.g. C_1 - C_{10}) alkoxy group, a cyclopentyl group, a cyclohexyl group, a phenyl group, a naphthyl group, a pyridinyl group, a pyrimidinyl group, a pyrazinyl group, a pyridazinyl group, an indolyl group, an isoindolyl group, an indazolyl group, a quinolinyl group, an isoquinolinyl group, a quinoxaliny group, a quinazoliny group, a cinnolinyl group, and a triazinyl group,

d_2 is an integer of 0 to 2,

d_3 is an integer of 0 to 3,

d_4 is an integer of 0 to 4,

d_6 is an integer of 0 to 6, and

* indicates a binding site to M in Formula 1, and *[†] indicates a binding site to a neighboring group.

55 [0020] In one embodiment, in Formula 1, a moiety represented by

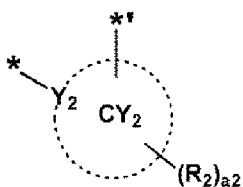

may be selected from groups represented by Formulae 4-1 to 4-40, but embodiments of the present disclosure are not limited thereto:

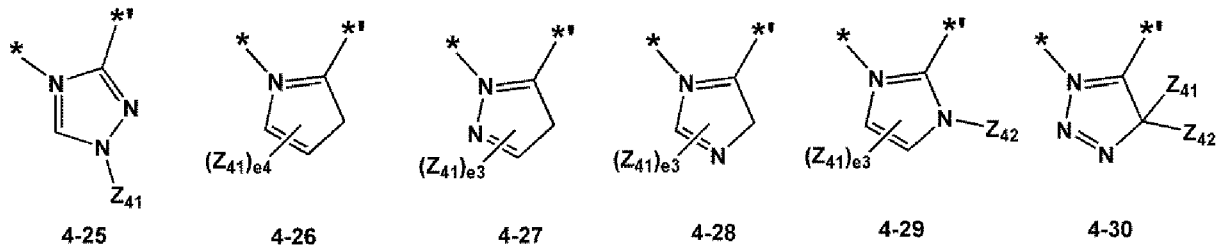
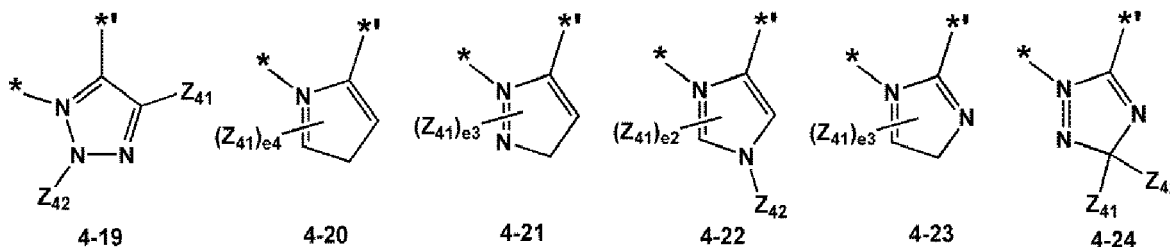
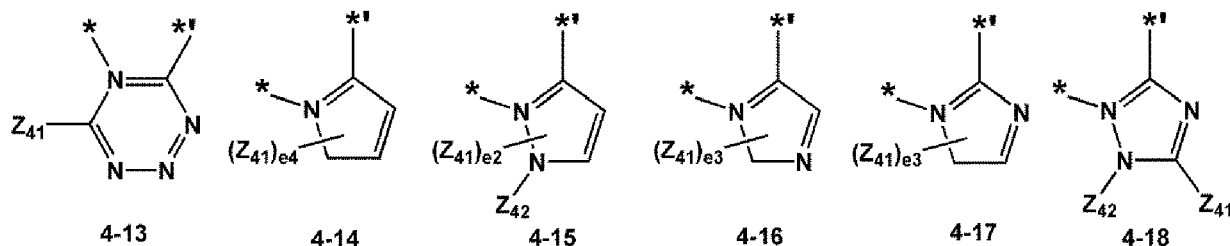
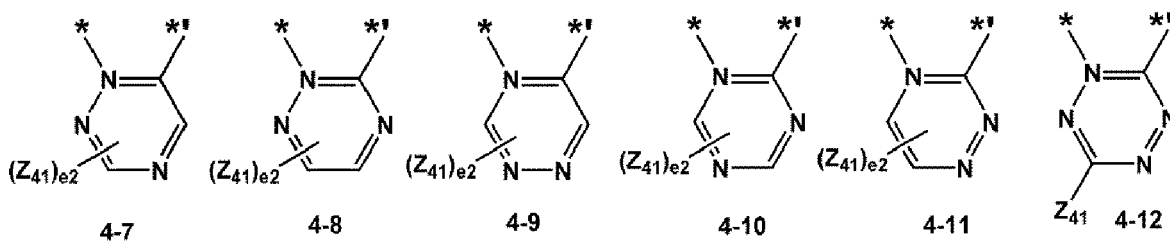
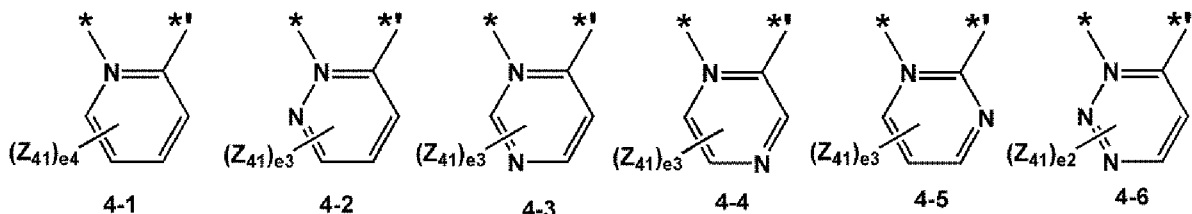

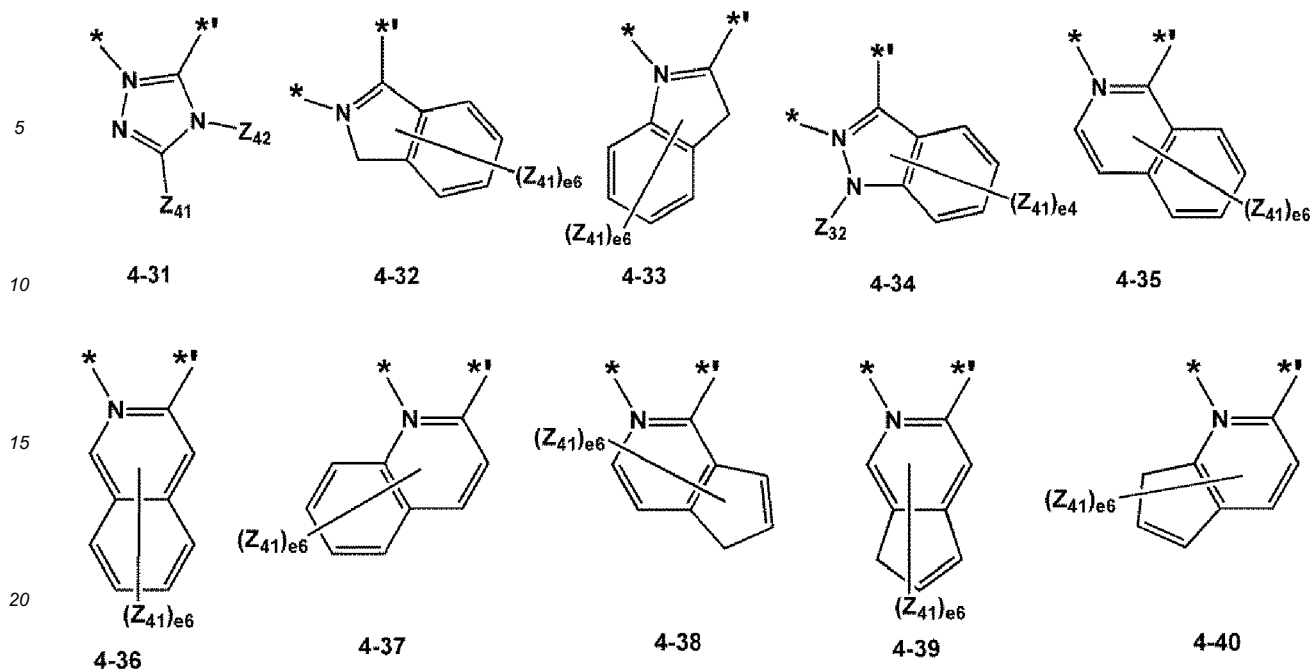

Z_{41} to Z_{42} are each independently selected from hydrogen, deuterium, -F, -Cl, -Br, -I, a hydroxyl group, a cyano group, a nitro group, an amidino group, a hydrazino group, a hydrazono group, a C_1 - C_{20} (e.g. C_1 - C_{10}) alkyl group, a C_2 - C_{20} (e.g. C_2 - C_{10}) alkenyl group, a C_2 - C_{20} (e.g. C_2 - C_{10}) alkynyl group, a C_1 - C_{20} (e.g. C_1 - C_{10}) alkoxy group, a cyclopentyl group, a cyclohexyl group, a phenyl group, a naphthyl group, a pyridinyl group, a pyrimidinyl group, a pyrazinyl group, a pyridazinyl group, an indolyl group, an isoindolyl group, an indazolyl group, a quinolinyl group, an isoquinolinyl group, a quinoxaliny group, a quinazoliny group, a cinnolinyl group, and a triazinyl group,

e_2 is an integer of 0 to 2,

e_3 is an integer of 0 to 3,

e_4 is an integer of 0 to 4,

e_6 is an integer of 0 to 6, and

* indicates a binding site to M in Formula 1, and *' indicates a binding site to a neighboring group.

[0021] In Formula 1, X_1 is $C(R_{11})$ or N, X_2 is $C(R_{12})$ or N, X_3 is $C(R_{13})$ or N, and X_4 is $C(R_{14})$ or N.

[0022] In one embodiment, X_1 may be $C(R_{11})$, X_2 may be $C(R_{12})$, X_3 may be $C(R_{13})$, and X_4 may be $C(R_{14})$, wherein R_{11} to R_{14} may each independently be selected from hydrogen, deuterium, -F, -Cl, -Br, -I, a hydroxyl group, a cyano group, a nitro group, an amidino group, a hydrazino group, a hydrazono group, a C_1 - C_{20} (e.g. C_1 - C_{10}) alkyl group, and a C_1 - C_{20} (e.g. C_1 - C_{10}) alkoxy group, but embodiments of the present disclosure are not limited thereto.

[0023] For example, each of X_1 to X_4 may be CH.

[0024] In Formula 1, Y_1 and Y_2 are each independently C or N.

[0025] In one embodiment, Y_1 and Y_2 may each be N, but embodiments of the present disclosure are not limited thereto.

[0026] In Formula 1, a bond between Y_1 and M and a bond between Y_2 and M are each a coordinate bond.

[0027] In Formula 1, A is selected from O, S, $N(R_3)$, $C(R_3)(R_4)$, and $Si(R_3)(R_4)$.

[0028] In Formula 1, T_1 to T_3 are each independently selected from a single bond, $*-O-*$, $*-S-*$, $*-C(R_5)(R_6)-*$, $*-C(R_5)=*$, $*=C(R_5)-*$, $*-C(R_5)=C(R_6)-*$, $*-C(=O)-*$, $*-C(=S)-*$, $*-C\equiv C-*$, $*-B(R_5)-*$, $*-N(R_5)-*$, $*-P(R_5)-*$, $*-Si(R_5)(R_6)-*$, and $*-Ge(R_5)(R_6)-*$.

[0029] In one embodiment, T_3 may be a single bond, and

T_1 and T_2 may each independently be selected from $*-O-*$, $*-S-*$, $*-C(R_7)(R_8)-*$, $*-B(R_7)-*$, $*-N(R_7)-*$, $*-P(R_7)-*$, $*-Si(R_7)(R_8)-*$, and $*-P(R_7)(R_8)-*$.

[0030] In one embodiment, T_3 may be a single bond, and

T_1 and T_2 may each independently be selected from $*-O-*$, $*-C(R_7)(R_8)-*$, $*-N(R_7)-*$, and $*-Si(R_7)(R_8)-*$.

[0031] In one embodiment, T_3 may be a single bond, and

T_1 and T_2 may each independently be selected from $*-O-*$, $*-C(Me)(Me)-*$, $*-N(Ph)-*$, and $*-Si(Me)(Me)-*$.

[0032] In one or more embodiments, T_3 may be a single bond, and T_1 and T_2 may be identical to each other, but embodiments of the present disclosure are not limited thereto.

[0033] In one embodiment, T_1 may be a single bond, and

T_2 and T_3 may each independently be selected from $*-O-*$, $*-S-*$, $*-C(R_7)(R_8)-*$, $*-B(R_7)-*$, $*-N(R_7)-*$, $*-P(R_7)-*$, $*-Si(R_7)(R_8)-*$, and $*-P(R_7)(R_8)-*$.

[0034] In one or more embodiments, T_1 may be a single bond, and T_2 and T_3 may be identical to each other, but embodiments of the present disclosure are not limited thereto.

[0035] In Formula 1, R_1 to R_6 and R_{11} to R_{14} are each independently selected from hydrogen, deuterium, -F, -Cl, -Br, -I, a hydroxyl group, a cyano group, a nitro group, an amidino group, a hydrazino group, a hydrazono group, a substituted or unsubstituted C_1-C_{60} (e.g. C_1-C_{20}) alkyl group, a substituted or unsubstituted C_2-C_{60} (e.g. C_2-C_{20}) alkenyl group, a substituted or unsubstituted C_2-C_{60} (e.g. C_2-C_{20}) alkynyl group, a substituted or unsubstituted C_1-C_{60} (e.g. C_1-C_{20}) alkoxy group, a substituted or unsubstituted C_3-C_{10} cycloalkyl group, a substituted or unsubstituted C_1-C_{10} heterocycloalkyl group, a substituted or unsubstituted C_3-C_{10} cycloalkenyl group, a substituted or unsubstituted C_1-C_{10} heterocycloalkenyl group, a substituted or unsubstituted C_6-C_{60} (e.g. C_6-C_{30}) aryl group, a substituted or unsubstituted C_6-C_{60} (e.g. C_6-C_{30}) aryloxy group, a substituted or unsubstituted C_6-C_{60} (e.g. C_6-C_{30}) arylthio group, a substituted or unsubstituted C_1-C_{60} (e.g. C_1-C_{20}) heteroaryl group, a substituted or unsubstituted monovalent non-aromatic condensed polycyclic group, a substituted or unsubstituted monovalent non-aromatic condensed heteropolycyclic group, $-Si(Q_1)(Q_2)(Q_3)$, $-N(Q_1)(Q_2)$, $-B(Q_1)(Q_2)$, $-P(Q_1)(Q_2)$, $-C(=O)(Q_1)$, $-S(=O)_2(Q_1)$, and $-P(=O)(Q_1)(Q_2)$, wherein two adjacent groups selected from R_1 to R_6 are optionally linked to each other to form a substituted or unsubstituted C_5-C_{60} (e.g. C_5-C_{30}) carbocyclic group or a substituted or unsubstituted C_1-C_{60} (e.g. C_1-C_{20}) heterocyclic group.

[0036] Q_1 to Q_3 are each independently selected from hydrogen, deuterium, -F, -Cl, -Br, -I, a hydroxyl group, a cyano group, a nitro group, an amidino group, a hydrazino group, a hydrazono group, a C_1-C_{60} (e.g. C_1-C_{20}) alkyl group, a C_2-C_{60} (e.g. C_2-C_{20}) alkenyl group, a C_2-C_{60} (e.g. C_2-C_{20}) alkynyl group, a C_1-C_{60} (e.g. C_1-C_{20}) alkoxy group, a C_3-C_{10} cycloalkyl group, a C_1-C_{10} heterocycloalkyl group, a C_3-C_{10} cycloalkenyl group, a C_1-C_{10} heterocycloalkenyl group, a C_6-C_{60} (e.g. C_6-C_{30}) aryl group, a C_1-C_{60} (e.g. C_1-C_{20}) heteroaryl group, a monovalent non-aromatic condensed polycyclic group, a monovalent non-aromatic condensed heteropolycyclic group, a biphenyl group, and a terphenyl group.

[0037] In one embodiment, R_1 to R_6 and R_{11} to R_{14} may each independently be selected from:

hydrogen, deuterium, -F, -Cl, -Br, -I, a hydroxyl group, a cyano group, a nitro group, an amidino group, a hydrazino group, a hydrazono group, a C_1-C_{20} (e.g. C_1-C_{10}) alkyl group, and a C_1-C_{20} (e.g. C_1-C_{10}) alkoxy group;

a C_1-C_{20} (e.g. C_1-C_{10}) alkyl group and a C_1-C_{20} (e.g. C_1-C_{10}) alkoxy group, each substituted with at least one selected from deuterium, -F, -Cl, -Br, -I, a hydroxyl group, a cyano group, a nitro group, an amidino group, a hydrazino group, a hydrazono group, a C_1-C_{20} (e.g. C_1-C_{10}) alkyl group, and a C_1-C_{20} (e.g. C_1-C_{10}) alkoxy group;

a cyclopentyl group, a cyclohexyl group, a phenyl group, a naphthyl group, a pyridinyl group, a pyrimidinyl group, a pyrazinyl group, a pyridazinyl group, a pyrrolyl group, an indolyl group, an isoindolyl group, an indazolyl group, a quinolinyl group, an isoquinolinyl group, a quinoxalinyl group, a quinazoliny group, a cinnolinyl group, and a triazinyl group; and

a cyclopentyl group, a cyclohexyl group, a phenyl group, a naphthyl group, a pyridinyl group, a pyrimidinyl group, a pyrazinyl group, a pyridazinyl group, a pyrrolyl group, an indolyl group, an isoindolyl group, an indazolyl group, a quinolinyl group, an isoquinolinyl group, a quinoxalinyl group, a quinazoliny group, a cinnolinyl group, and a triazinyl group, each substituted with at least one selected from deuterium, -F, -Cl, -Br, -I, a hydroxyl group, a cyano group, a nitro group, an amidino group, a hydrazino group, a hydrazono group, a C_1-C_{20} (e.g. C_1-C_{10}) alkyl group, a C_1-C_{20} (e.g. C_1-C_{10}) alkoxy group, a cyclopentyl group, a cyclohexyl group, a phenyl group, a naphthyl group, a pyridinyl group, a pyrimidinyl group, a pyrazinyl group, a pyridazinyl group, an indolyl group, an isoindolyl group, an indazolyl group, a quinolinyl group, an isoquinolinyl group, a quinoxalinyl group, a quinazoliny group, a cinnolinyl group, and a triazinyl group, $-Si(Q_{31})(Q_{32})(Q_{33})$, $-N(Q_{31})(Q_{32})$, $-B(Q_{31})(Q_{32})$, $-C(=O)(Q_{31})$, $-S(=O)_2(Q_{31})$, and $-P(=O)(Q_{31})(Q_{32})$;

and $-Si(Q_1)(Q_2)(Q_3)$, $-N(Q_1)(Q_2)$, $-B(Q_1)(Q_2)$, $-C(=O)(Q_1)$, $-S(=O)_2(Q_1)$, and $-P(=O)(Q_1)(Q_2)$ but embodiments of the present disclosure are not limited thereto, and

Q_1 to Q_3 and Q_{31} to Q_{33} may each independently be selected from hydrogen, deuterium, -F, -Cl, -Br, -I, a cyano group, a C_1-C_{20} (e.g. C_1-C_{10}) alkyl group, a C_2-C_{20} (e.g. C_2-C_{10}) alkenyl group, a C_2-C_{20} (e.g. C_2-C_{10}) alkynyl group, a C_1-C_{20} (e.g. C_1-C_{10}) alkoxy group, a C_3-C_{10} cycloalkyl group, a C_1-C_{10} heterocycloalkyl group, a C_3-C_{10} cycloalkenyl group, a C_1-C_{10} heterocycloalkenyl group, a C_6-C_{20} aryl group, a C_1-C_{20} heteroaryl group, a monovalent non-aromatic condensed polycyclic group, and a monovalent non-aromatic condensed heteropolycyclic group.

[0038] In Formula 1, a_1 and a_2 are each independently an integer of 1 to 5, wherein, when a_1 is two or more, two or more of $R_1(s)$ are identical to or different from each other, and when a_2 is two or more, two or more of $R_2(s)$ are identical to or different from each other.

[0039] In one embodiment, Formula 1 may be represented by Formula 1-1 or 1-2:

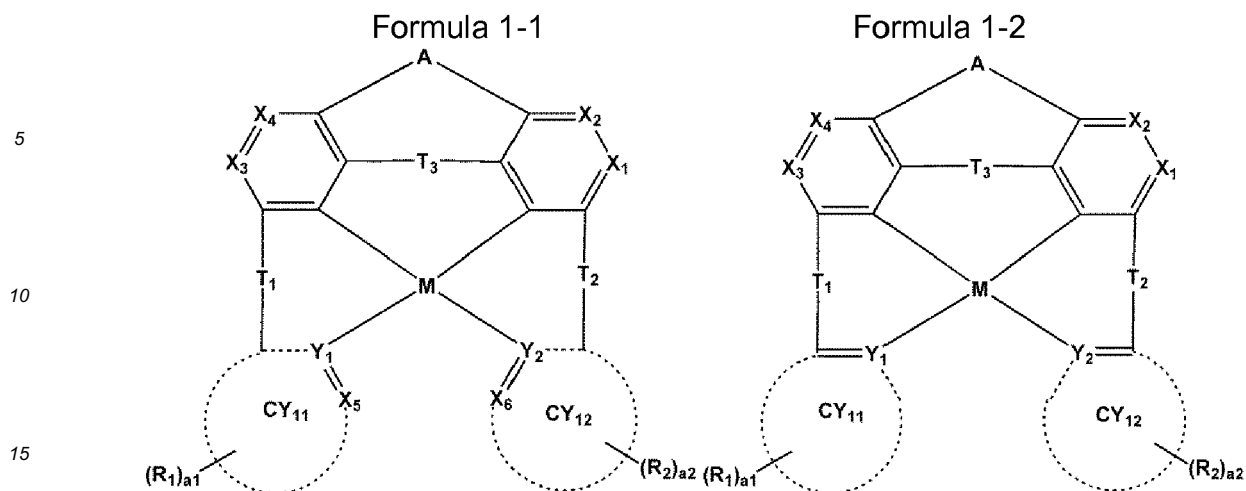

[0040] In Formulae 1-1 and 1-2,

20 M, A, X₁ to X₄, T₁ to T₃, Y₁, Y₂, R₁, R₂, a1, and a2 are respectively the same as defined above, CY₁₁ and CY₁₂ are respectively the same as defined in connection with CY₁ and CY₂, and X₅ is C(R₁₅) or N, and X₆ is C(R₁₆) or N.

In one embodiment, in Formulae 1-1 and 1-2,

25 X₁ to X₄ may each be CH,

T₃ may be a single bond,

A may be selected from O, S, N(R₃), C(R₃)(R₄), and Si(R₃)(R₄),

R₃ and R₄ may each independently be selected from:

30 hydrogen, deuterium, -F, -Cl, -Br, -I, a hydroxyl group, a cyano group, a C₁-C₂₀ (e.g. C₁-C₁₀) alkyl group, a C₁-C₂₀ (e.g. C₁-C₁₀) alkoxy group, a phenyl group, a naphthyl group, a pyridinyl group, a pyrimidinyl group, a pyrazinyl group, and a pyridazinyl group; and

a phenyl group, a naphthyl group, a pyridinyl group, a pyrimidinyl group, a pyrazinyl group, a pyridazinyl group, each substituted with at least one selected from deuterium, -F, -Cl, -Br, -I, a hydroxyl group, a cyano group, a C₁-C₂₀ (e.g. C₁-C₁₀) alkyl group, and a C₁-C₂₀ (e.g. C₁-C₁₀) alkoxy group, but embodiments of the present disclosure are not limited thereto.

35

[0041] In one embodiment, Formula 1 may be represented by one of Formulae 1-1a to 1-1d:

40 Formula 1-1a

Formula 1-1b

40

45

50

55

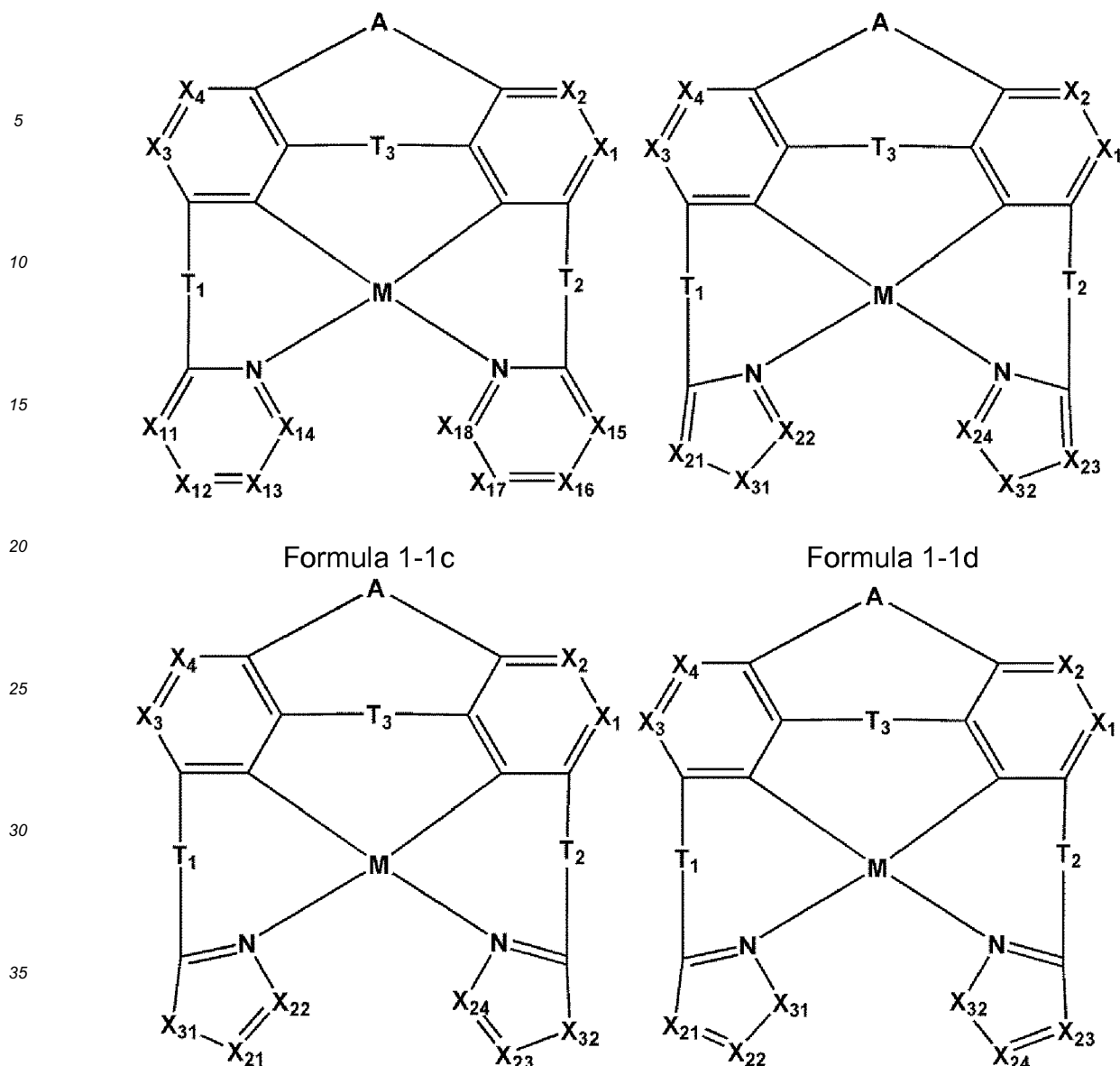

[0042] In Formulae 1-1a to 1-1d,

M, A, X₁ to X₄, and T₁ to T₃ are respectively the same as defined above,

X₁₁ is C(R_{11a}) or N, X₁₂ is C(R_{12a}) or N, X₁₃ is C(R_{13a}) or N, X₁₄ is C(R_{14a}) or N, X₁₅ is C(R_{15a}) or N, X₁₆ is C(R_{16a}) or N, X₁₇ is C(R_{17a}) or N, and X₁₈ is C(R_{18a}) or N,

R_{11a} to R_{14a} are respectively the same as defined in connection with R₁, and R_{15a} to R_{18a} are respectively the same as defined in connection with R₂,

two neighboring groups selected from R_{11a} to R_{18a} are optionally linked to form a substituted or unsubstituted C₅-C₆₀ (e.g. C₅-C₃₀) carbocyclic group or a substituted or unsubstituted C₁-C₆₀ (e.g. C₁-C₂₀) heterocyclic group,

X₂₁ is C(R_{21a}) or N, X₂₂ is C(R_{22a}) or N, X₂₃ is C(R_{23a}) or N, and X₂₄ is C(R_{24a}) or N,

X₃₁ is C(R_{31a})(R_{31b}) or N(R_{31a}), and X₃₂ is C(R_{32a})(R_{32b}) or N(R_{32a}),

R_{21a}, R_{22a}, R_{31a}, and R_{31b} are respectively the same as defined in connection with R₁, and R_{23a}, R_{24a}, R_{32a}, and R_{32b} are respectively the same as defined in connection with R₂, and

two neighboring groups selected from R_{21a} to R_{24a}, R_{31a}, R_{31b}, R_{32a}, and R_{32b} are optionally linked to form a substituted or unsubstituted C₅-C₆₀ (e.g. C₅-C₃₀) carbocyclic group or a substituted or unsubstituted C₁-C₆₀ (e.g. C₁-C₂₀) heterocyclic group.

[0043] The organometallic compound may be selected from Compounds 1 to 107:

5

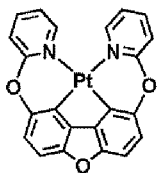

1

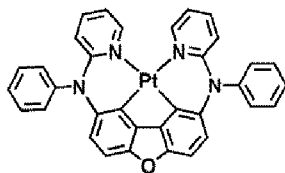

2

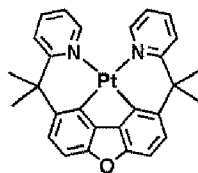

3

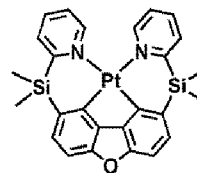

4

10

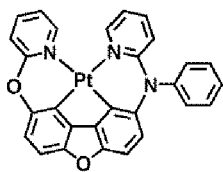

5

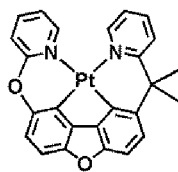

6

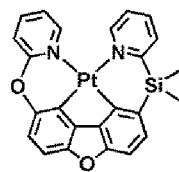

7

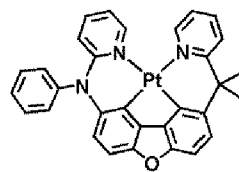

8

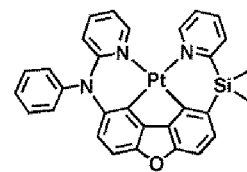

9

15

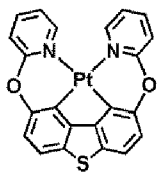

10

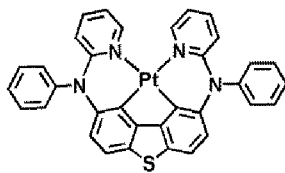

11

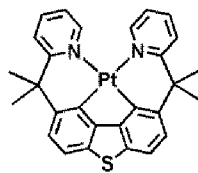

12

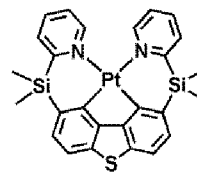

13

25

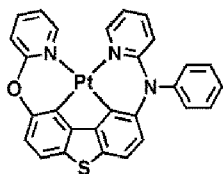

14

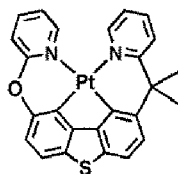

15

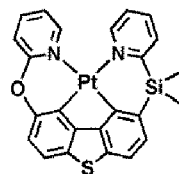

16

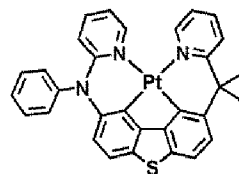

17

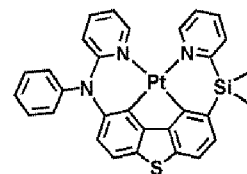

18

30

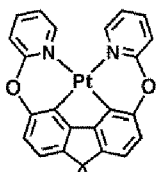

19

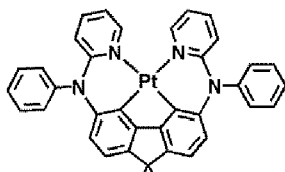

20

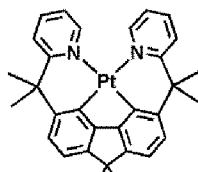

21

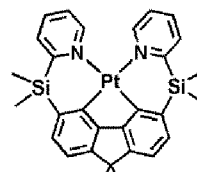

22

35

40

45

50

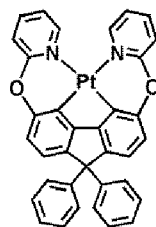

23

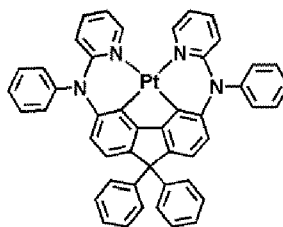

24

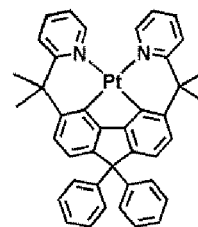

25

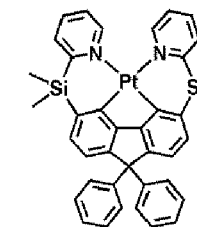

26

55

5

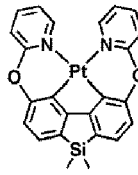

27

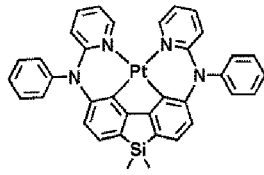

28

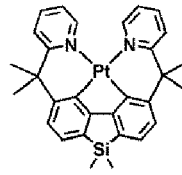

29

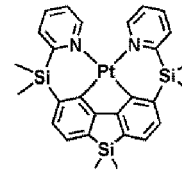

30

10

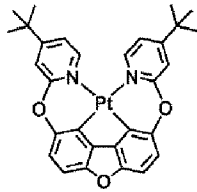

31

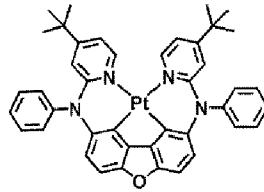

32

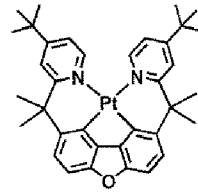

33

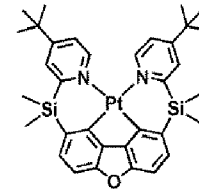

34

15

20

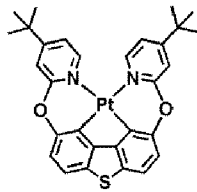

35

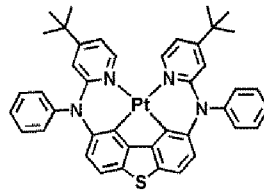

36

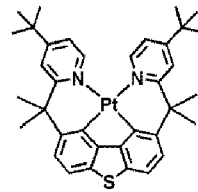

37

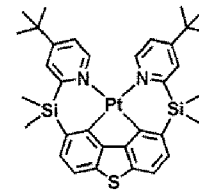

38

25

30

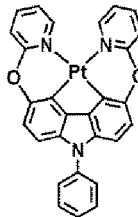

39

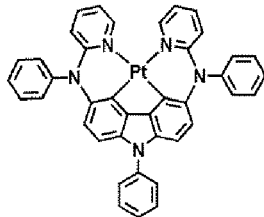

40

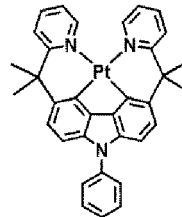

41

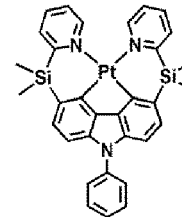

42

35

40

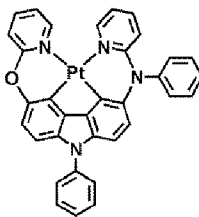

43

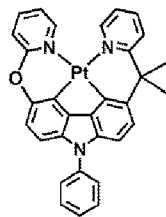

44

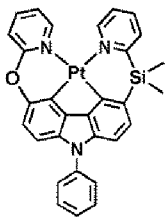

45

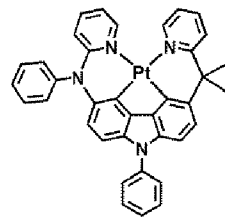

46

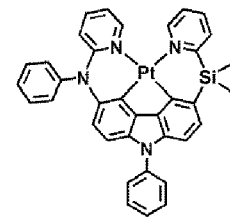

47

45

50

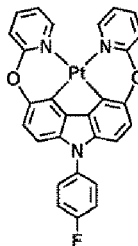

48

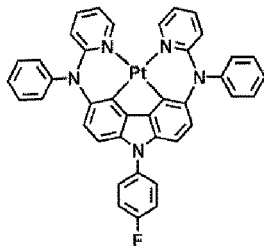

49

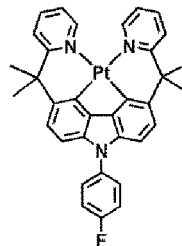

50

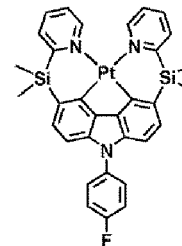

51

55

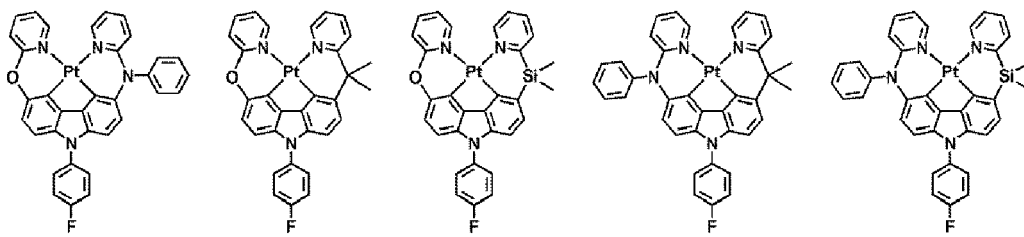

52 53 54 55 56

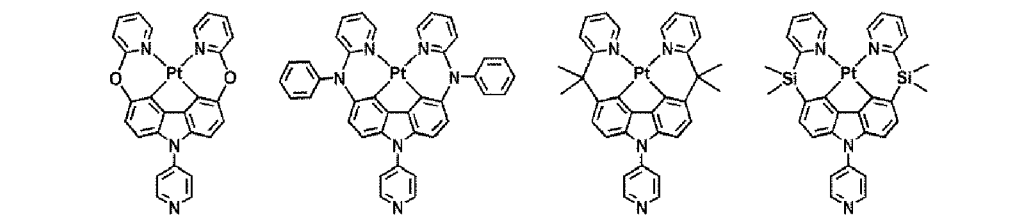

57 58 59 60

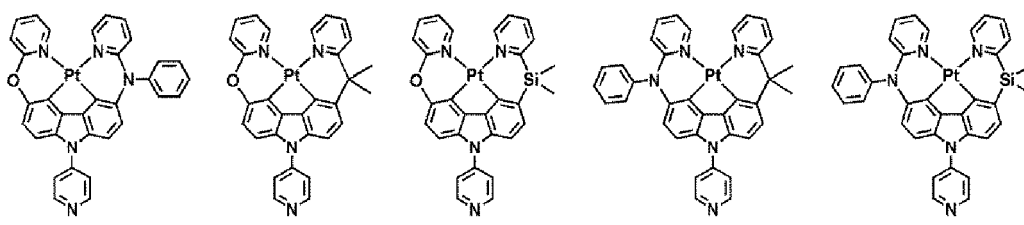

61 62 63 64 65

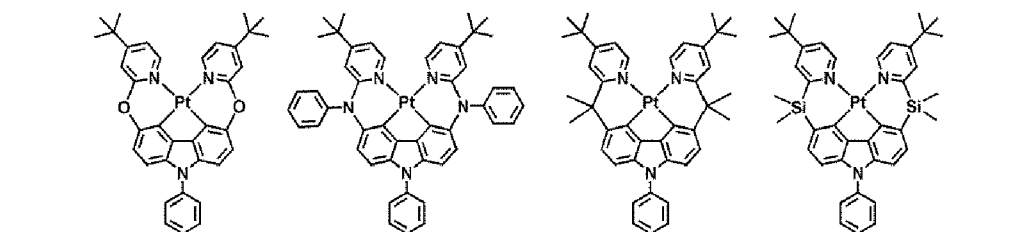

66 67 68 69

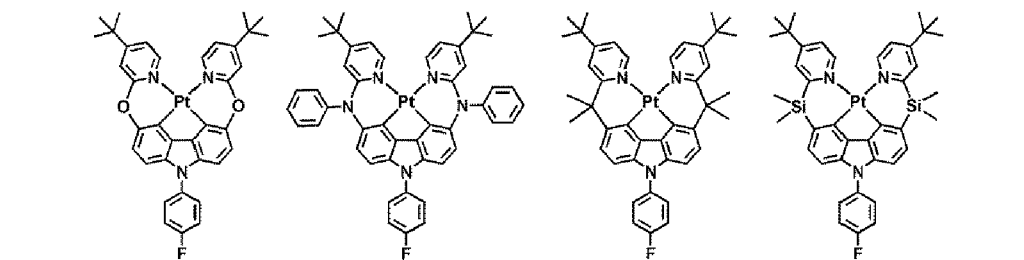

70 71 72 73

5

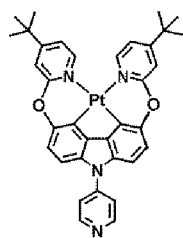

74

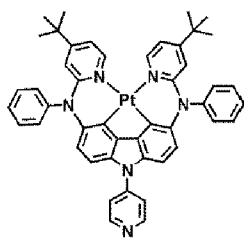

75

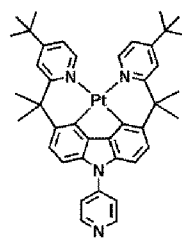

76

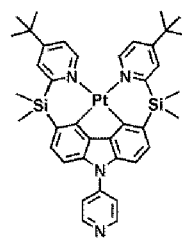

77

10

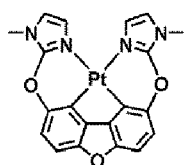

78

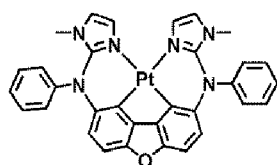

79

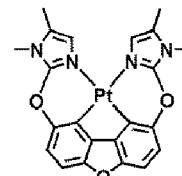

80

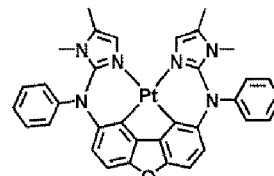

81

15

20

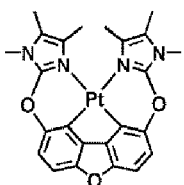

82

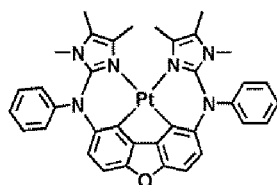

83

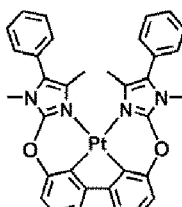

84

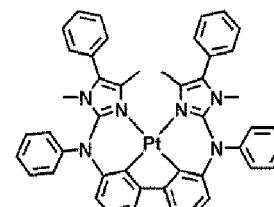

85

25

30

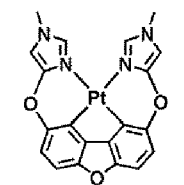

86

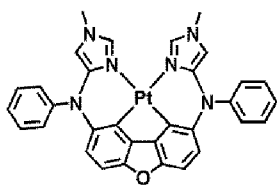

87

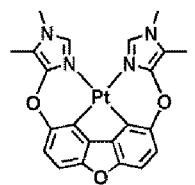

88

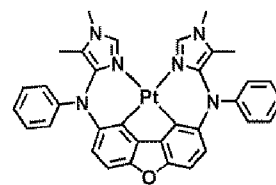

89

35

40

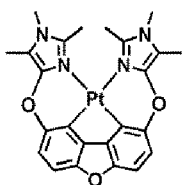

90

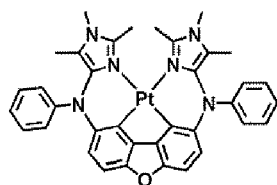

91

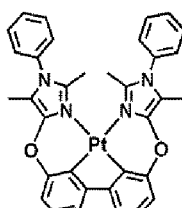

92

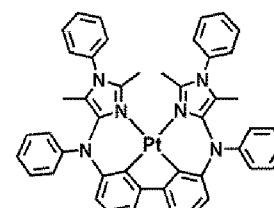

93

45

50

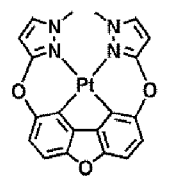

94

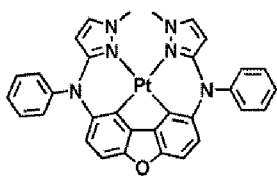

95

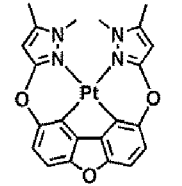

96

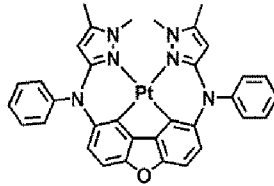

97

55

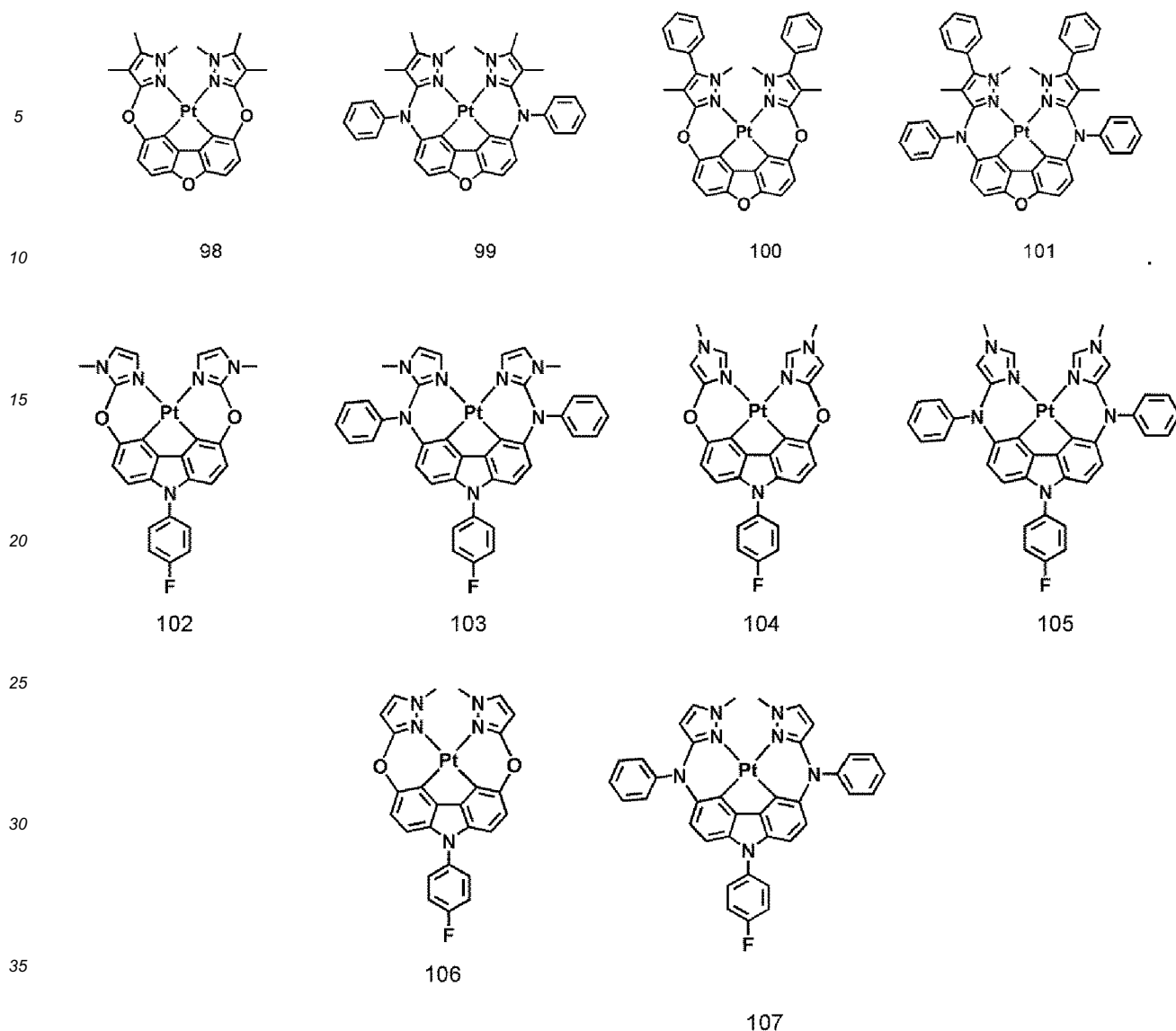

[0044] The organometallic compound represented by Formula 1 is suitable for high efficiency, high color purity, and energy transfer.

[0045] For example, since the organometallic compound has a structure in which a condensed ring such as a fluorene, a carbazole, a dibenzosilane, a dibenzofuran, or a dibenzothiophene is linked to a metal via two covalent bonds in a tetradentate ligand, the organometallic compound is rigid, as compared with a bidentate or tridentate ligand structure. In addition, since the organometallic compound suppresses or reduces vibration, the organometallic compound has features of good blue light wavelength and efficiency. In addition, since there are many metal-ligand binding sites, material durability may increase and thus the organometallic compound may have a feature of good lifespan. Furthermore, in the organometallic compound, a portion at which a highest occupied molecular orbital (HOMO) level is positioned is in the form of a condensed ring, vibration may be further suppressed or reduced, thereby reducing a full width at half maximum (FWHM).

[0046] A synthesis method for the organometallic compound represented by Formula 1 would be apparent to those of ordinary skill in the art by referring to the following examples.

[0047] At least one of the organometallic compound of Formula 1 may be used between a pair of electrodes of an organic light-emitting device. Accordingly, provided is an organic light-emitting device including: a first electrode; a second electrode facing the first electrode; and an organic layer between the first electrode and the second electrode, the organic layer including an emission layer, wherein the organic layer includes at least one organometallic cyclic compound represented by Formula 1.

[0048] The expression "(an organic layer) includes at least one of organometallic compounds," as used herein, may include a case in which "(an organic layer) includes identical organometallic compounds represented by Formula 1" and

a case in which "(an organic layer) includes two or more different organometallic compounds represented by Formula 1."

[0049] For example, the organic layer may include, as the organometallic compound, only Compound 1. In this regard, Compound 1 may be present in an emission layer of the organic light-emitting device. In one or more embodiments, the organic layer may include, as the organometallic compound, Compound 1 and Compound 2. In this regard, Compound 1 and Compound 2 may be present in an identical layer (for example, Compound 1 and Compound 2 may all be present in an emission layer), or different layers (for example, Compound 1 may be present in an emission layer and Compound 2 may be present in an electron transport region).

[0050] According to one embodiment,

the first electrode of the organic light-emitting device may be an anode, the second electrode of the organic light-emitting device may be a cathode, the organic layer may further include a hole transport region between the first electrode and the emission layer and an electron transport region between the emission layer and the second electrode, the hole transport region may include a hole injection layer, a hole transport layer, a buffer layer, an emission auxiliary layer, an electron blocking layer, or any combination thereof, and

the electron transport region may include a hole blocking layer, an electron transport layer, an electron injection layer, or any combination thereof.

[0051] The emission layer may include the organometallic compound,

[0052] The organometallic compound included in the emission layer may serve as a phosphorescent dopant so that phosphorescence may be emitted from the emission layer; or

[0053] the organometallic compound included in the emission layer may serve as a delayed fluorescent dopant so that delayed fluorescence may be emitted from the emission layer.

[0054] The emission layer may consist of the organometallic compound; or

the emission layer may further include a host,

wherein an amount of the organometallic compound included in the emission layer may be in a range of about 0.01 parts by weight to about 50 parts by weight based on 100 parts by weight of the emission layer. For example, an amount of the organometallic compound included in the emission layer may be in a range of about 0.01 parts by weight to about 20 parts by weight based on 100 parts by weight of the emission layer. For example, an amount of the organometallic compound included in the emission layer may be in a range of about 5 parts by weight to about 15 parts by weight based on 100 parts by weight of the emission layer.

[0055] The emission layer may further include at least one selected from a pyrene-containing compound, an arylamine-based compound, and a styryl-based compound that will be described below, but embodiments of the present disclosure are not limited thereto. Here, any suitable host compound available in the art may be suitably or appropriately selected.

[0056] An aspect of an embodiment of the present disclosure provides an electronic apparatus including: a thin film transistor; and the organic light-emitting device, wherein the thin film transistor includes a source electrode, a drain electrode, an activation layer, and a gate electrode, and wherein at least one of the source electrode and the drain electrode of the thin film transistor may be electrically coupled with (e.g., electrically connected with) the first electrode of the organic light-emitting device.

[0057] The term "organic layer," as used herein, refers to a single layer and/or a plurality of layers disposed between the first electrode and the second electrode of the organic light-emitting device. A material included in the "organic layer" is not limited to an organic material.

Description of FIG. 1

[0058] FIG. 1 is a schematic view of an organic light-emitting device 10 according to an embodiment. The organic light-emitting device 10 includes a first electrode 110, an organic layer 150, and a second electrode 190.

[0059] Hereinafter, the structure of the organic light-emitting device 10 according to an embodiment and a method of manufacturing the organic light-emitting device 10 will be described in connection with FIG. 1.

First electrode 110

[0060] In FIG. 1, a substrate may be additionally disposed under the first electrode 110 or above the second electrode 190. The substrate may be a glass substrate or a plastic substrate, each having excellent mechanical strength, thermal stability, transparency, surface smoothness, ease of handling, and water resistance.

[0061] The first electrode 110 may be formed by depositing or sputtering a material for forming the first electrode 110 on the substrate. When the first electrode 110 is an anode, the material for a first electrode may be selected from materials with a high work function to facilitate hole injection.

[0062] The first electrode 110 may be a reflective electrode, a semi-transmissive electrode, or a transmissive electrode. When the first electrode 110 is a transmissive electrode, a material for forming a first electrode may be selected from

indium tin oxide (ITO), indium zinc oxide (IZO), tin oxide (SnO₂), zinc oxide (ZnO), and any combinations thereof, but embodiments of the present disclosure are not limited thereto. In one or more embodiments, when the first electrode 110 is a semi-transmissive electrode or a reflectable electrode, a material for forming a first electrode may be selected from magnesium (Mg), silver (Ag), aluminium (Al), aluminium-lithium (Al-Li), calcium (Ca), magnesium-indium (Mg-In), magnesium-silver (Mg-Ag), and any combinations thereof, but embodiments of the present disclosure are not limited thereto.

[0063] The first electrode 110 may have a single-layered structure, or a multi-layered structure including two or more layers. For example, the first electrode 110 may have a three-layered structure of ITO/Ag/ITO, but the structure of the first electrode 110 is not limited thereto.

Organic layer 150

[0064] The organic layer 150 is disposed on the first electrode 110. The organic layer 150 may include an emission layer.

[0065] The organic layer 150 may further include a hole transport region between the first electrode 110 and the emission layer, and an electron transport region between the emission layer and the second electrode 190.

Hole transport region in organic layer 150

[0066] The hole transport region may have i) a single-layered structure including a single layer including a single material, ii) a single-layered structure including a single layer including a plurality of different materials, or iii) a multi-layered structure having a plurality of layers including a plurality of different materials.

[0067] The hole transport region may include at least one layer selected from a hole injection layer, a hole transport layer, a buffer layer, an emission auxiliary layer, and an electron blocking layer.

[0068] For example, the hole transport region may have a single-layered structure including a single layer including a plurality of different materials, or a multi-layered structure having a hole injection layer/hole transport layer structure, a hole injection layer/hole transport layer/emission auxiliary layer structure, a hole injection layer/emission auxiliary layer structure, a hole transport layer/emission auxiliary layer structure, or a hole injection layer/hole transport layer/electron blocking layer structure, wherein for each structure, constituting layers are sequentially stacked from the first electrode 110 in this stated order, but the structure of the hole transport region is not limited thereto.

[0069] The hole transport region may include at least one selected from m-MTDATA, TDATA, 2-TNATA, NPB (NPD), β-NPB, TPD, Spiro-TPD, Spiro-NPB, methylated-NPB, TAPC, HMTDPD, 4,4',4"-tris(N-carbazolyl)triphenylamine (TCTA), polyaniline/dodecylbenzenesulfonic acid (PANI/DBSA), poly(3,4-ethylenedioxythiophene)/poly(4-styrenesulfonate) (PEDOT/PSS), polyaniline/camphor sulfonic acid (PANI/CSA), polyaniline/poly(4-styrenesulfonate) (PANI/PSS), a compound represented by Formula 201, and a compound represented by Formula 202:

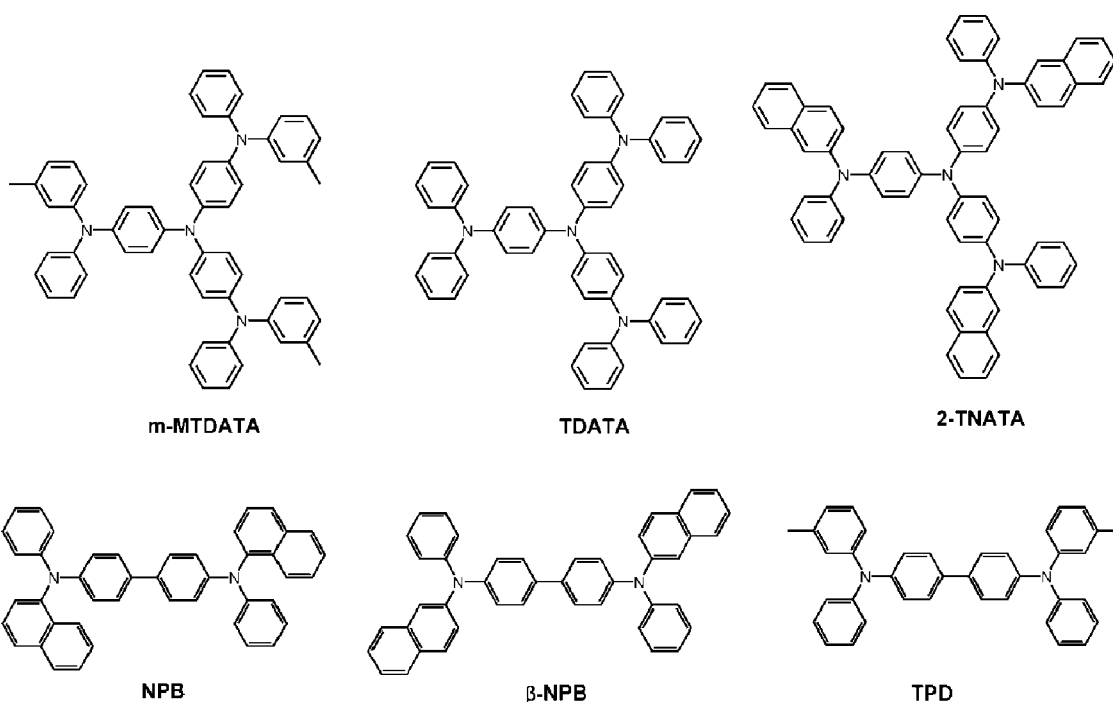

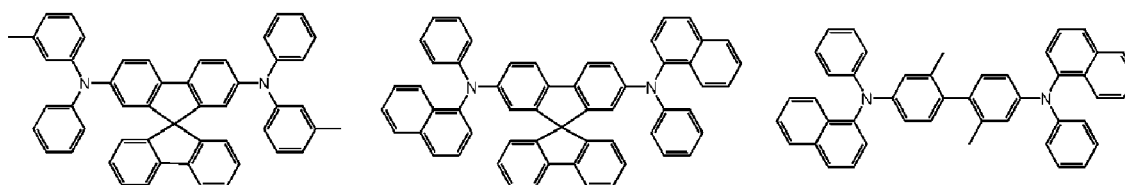

Spiro-TPD

Spiro-NPB

methylated NPB

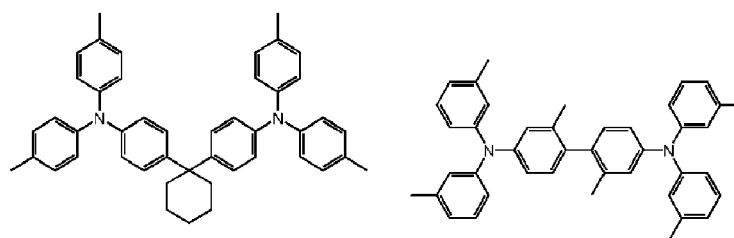

TAPC

HMTPD

Formula 201

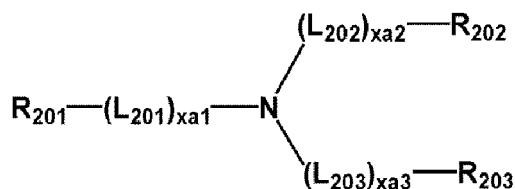

Formula 202

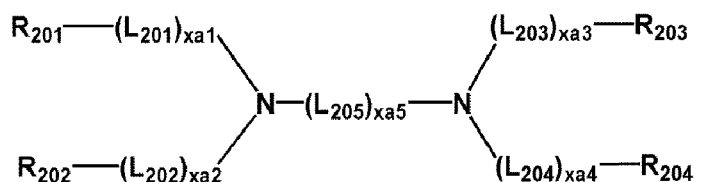

[0070] In Formulae 201 and 202,

40 L_{201} to L_{204} may each independently be selected from a substituted or unsubstituted C_3 - C_{10} cycloalkylene group, a substituted or unsubstituted C_1 - C_{10} heterocycloalkylene group, a substituted or unsubstituted C_3 - C_{10} cycloalkenylene group, a substituted or unsubstituted C_1 - C_{10} heterocycloalkenylene group, a substituted or unsubstituted C_6 - C_{60} (e.g. C_6 - C_{32}) arylene group, a substituted or unsubstituted C_1 - C_{60} (e.g. C_1 - C_{20}) heteroarylene group, a substituted or unsubstituted divalent non-aromatic condensed polycyclic group, and a substituted or unsubstituted divalent non-aromatic condensed heteropolycyclic group,

45 L_{205} may be selected from $^*O^*$, $^*S^*$, $^*N(Q_{201})^*$, a substituted or unsubstituted C_1 - C_{20} alkylene group, a substituted or unsubstituted C_2 - C_{20} alkenylene group, a substituted or unsubstituted C_3 - C_{10} cycloalkylene group, a substituted or unsubstituted C_1 - C_{10} heterocycloalkylene group, a substituted or unsubstituted C_3 - C_{10} cycloalkenylene group, a substituted or unsubstituted C_1 - C_{10} heterocycloalkenylene group, a substituted or unsubstituted C_6 - C_{60} (e.g. C_6 - C_{32}) arylene group, a substituted or unsubstituted C_1 - C_{60} (e.g. C_1 - C_{20}) heteroarylene group, a substituted or unsubstituted divalent non-aromatic condensed polycyclic group, and a substituted or unsubstituted divalent non-aromatic condensed heteropolycyclic group,

50 xa_1 to xa_4 may each independently be an integer of 0 to 3,

xa_5 may be an integer of 1 to 10, and

55 R_{201} to R_{204} and Q_{201} may each independently be selected from a substituted or unsubstituted C_3 - C_{10} cycloalkyl group, a substituted or unsubstituted C_1 - C_{10} heterocycloalkyl group, a substituted or unsubstituted C_3 - C_{10} cycloalkenyl group, a substituted or unsubstituted C_1 - C_{10} heterocycloalkenyl group, a substituted or unsubstituted C_6 - C_{60} (e.g. C_6 - C_{32}) aryl group, a substituted or unsubstituted C_6 - C_{60} (e.g. C_6 - C_{32}) aryloxy group, a substituted or unsub-

stituted C₆-C₆₀ (e.g. C₆-C₃₂) arylthio group, a substituted or unsubstituted C₁-C₆₀ (e.g. C₁-C₂₀) heteroaryl group, a substituted or unsubstituted monovalent non-aromatic condensed polycyclic group, and a substituted or unsubstituted monovalent non-aromatic condensed heteropolycyclic group.

5 **[0071]** For example, R₂₀₁ and R₂₀₂ in Formula 202 may optionally be linked each other via a single bond, a dimethyl-methylene group, or a diphenyl-methylene group, and R₂₀₃ and R₂₀₄ in Formula 202 may optionally be linked each other via a single bond, a dimethyl-methylene group, or a diphenyl-methylene group.

[0072] In one or more embodiments, in Formulae 201 and 202, L₂₀₁ to L₂₀₅ may each independently be selected from:

10 a phenylene group, a pentalenylene group, an indenylene group, a naphthylene group, an azulenylenylene group, a heptalenylene group, an indacenylene group, an acenaphthylene group, a fluorenylene group, a spiro-bifluorenylene group, a benzofluorenylene group, a dibenzofluorenylene group, a phenalenylene group, a phenanthrenylene group, an anthracenylene group, a fluoranthenylene group, a triphenylenylene group, a pyrenylene group, a chrysenylene group, a naphthacenylene group, a picenylene group, a perylenylene group, a pentaphenylenylene group, a hexacenylenylene group, a pentacenylene group, a rubicenylene group, a coronenylene group, an ovalenylene group, a thiophenylene group, a furanylene group, a carbazolylenylene group, an indolylenylene group, an isoindolylenylene group, a benzofuranylene group, a benzothiophenylene group, a dibenzofuranylene group, a dibenzothiophenylene group, a benzocarbazolylenylene group, a dibenzocarbazolylenylene group, a dibenzosilolylenylene group, and a pyridinylenylene group;

20 and
a phenylene group, a pentalenylene group, an indenylene group, a naphthylene group, an azulenylenylene group, a heptalenylene group, an indacenylene group, an acenaphthylene group, a fluorenylene group, a spiro-bifluorenylene group, a benzofluorenylene group, a dibenzofluorenylene group, a phenalenylene group, a phenanthrenylene group, an anthracenylene group, a fluoranthenylene group, a triphenylenylene group, a pyrenylene group, a chrysenylene group, a naphthacenylene group, a picenylene group, a perylenylene group, a pentaphenylenylene group, a hexacenylenylene group, a pentacenylene group, a rubicenylene group, a coronenylene group, an ovalenylene group, a thiophenylene group, a furanylene group, a carbazolylenylene group, an indolylenylene group, an isoindolylenylene group, a benzofuranylene group, a benzothiophenylene group, a dibenzofuranylene group, a dibenzothiophenylene group, a benzocarbazolylenylene group, a dibenzocarbazolylenylene group, a dibenzosilolylenylene group, and a pyridinylenylene group,
25 each substituted with at least one selected from deuterium, -F, -Cl, -Br, -I, a hydroxyl group, a cyano group, a nitro group, an amidino group, a hydrazino group, a hydrazono group, a C₁-C₂₀ alkyl group, a C₁-C₂₀ alkoxy group, a cyclopentyl group, a cyclohexyl group, a cycloheptyl group, a cyclopentenyl group, a cyclohexenyl group, a phenyl group, a biphenyl group, a terphenyl group, a phenyl group substituted with a C₁-C₁₀ alkyl group, a phenyl group substituted with -F, a pentalenyl group, an indenyl group, a naphthyl group, an azulenylyl group, a heptalenyl group, an indacenyl group, an acenaphthyl group, a fluorenyl group, a spiro-bifluorenyl group, a benzofluorenyl group, a dibenzofluorenyl group, a phenalenyl group, a phenanthrenyl group, an anthracenyl group, a fluoranthenyl group, a triphenylenyl group, a pyrenyl group, a chrysenyl group, a naphthacenyl group, a picenyl group, a perylenyl group, a pentaphenylyl group, a hexacenylyl group, a pentacenylyl group, a rubicenyl group, a coronenyl group, an ovalenyl group, a thiophenyl group, a furanyl group, a carbazolyl group, an indolyl group, an isoindolyl group, a benzofuranyl group, a benzothiophenyl group, a dibenzofuranyl group, a dibenzothiophenyl group, a benzocarbazolyl group, a dibenzocarbazolyl group, a dibenzosilolyl group, and a pyridinyl group, -Si(Q₃₁)(Q₃₂)(Q₃₃), and -N(Q₃₁)(Q₃₂), and Q₃₁ to Q₃₃ may each independently be selected from a C₁-C₁₀ alkyl group, a C₁-C₁₀ alkoxy group, a phenyl group, a biphenyl group, a terphenyl group, and a naphthyl group.

45 **[0073]** In one or more embodiments, xa1 to xa4 may each independently be 0, 1, or 2.

[0074] In one or more embodiments, xa5 may be 1, 2, 3, or 4.

[0075] In one or more embodiments, R₂₀₁ to R₂₀₄ and Q₂₀₁ may each independently be selected from:

50 a phenyl group, a biphenyl group, a terphenyl group, a pentalenyl group, an indenyl group, a naphthyl group, an azulenylyl group, a heptalenyl group, an indacenyl group, an acenaphthyl group, a fluorenyl group, a spiro-bifluorenyl group, a benzofluorenyl group, a dibenzofluorenyl group, a phenalenyl group, a phenanthrenyl group, an anthracenyl group, a fluoranthenyl group, a triphenylenyl group, a pyrenyl group, a chrysenyl group, a naphthacenyl group, a picenyl group, a perylenyl group, a pentaphenylyl group, a hexacenylyl group, a pentacenylyl group, a rubicenyl group, a coronenyl group, an ovalenyl group, a thiophenyl group, a furanyl group, a carbazolyl group, an indolyl group, an isoindolyl group, a benzofuranyl group, a benzothiophenyl group, a dibenzofuranyl group, a dibenzothiophenyl group, a benzocarbazolyl group, a dibenzocarbazolyl group, a dibenzosilolyl group, and a pyridinyl group; and
55 a phenyl group, a biphenyl group, a terphenyl group, a pentalenyl group, an indenyl group, a naphthyl group, an azulenylyl group, a heptalenyl group, an indacenyl group, an acenaphthyl group, a fluorenyl group, a spiro-bifluorenyl

group, a benzofluorenyl group, a dibenzofluorenyl group, a phenalenyl group, a phenanthrenyl group, an anthracenyl group, a fluoranthenyl group, a triphenylenyl group, a pyrenyl group, a chrysenyl group, a naphthacenyl group, a picenyl group, a perylenyl group, a pentaphenyl group, a hexacacenyl group, a pentacacenyl group, a rubicenyl group, a coronenyl group, an ovalenyl group, a thiophenyl group, a furanyl group, a carbazolyl group, an indolyl group, an isoindolyl group, a benzofuranyl group, a benzothiophenyl group, a dibenzofuranyl group, a dibenzothiophenyl group, a benzocarbazolyl group, a dibenzocarbazolyl group, a dibenzosilolyl group, and a pyridinyl group, each substituted with at least one selected from deuterium, -F, -Cl, -Br, -I, a hydroxyl group, a cyano group, a nitro group, an amidino group, a hydrazino group, a hydrazono group, a C₁-C₂₀ alkyl group, a C₁-C₂₀ alkoxy group, a cyclopentyl group, a cyclohexyl group, a cycloheptyl group, a cyclopentenyl group, a cyclohexenyl group, a phenyl group, a biphenyl group, a terphenyl group, a phenyl group substituted with a C₁-C₁₀ alkyl group, a phenyl group substituted with -F, a pentalenyl group, an indenyl group, a naphthyl group, an azulenyl group, a heptalenyl group, an indacenyl group, an acenaphthyl group, a fluorenyl group, a spiro-bifluorenyl group, a benzofluorenyl group, a dibenzofluorenyl group, a phenalenyl group, a phenanthrenyl group, an anthracenyl group, a fluoranthenyl group, a triphenylenyl group, a pyrenyl group, a chrysenyl group, a naphthacenyl group, a picenyl group, a perylenyl group, a pentaphenyl group, a hexacacenyl group, a pentacacenyl group, a rubicenyl group, a coronenyl group, an ovalenyl group, a thiophenyl group, a furanyl group, a carbazolyl group, an indolyl group, an isoindolyl group, a benzofuranyl group, a benzothiophenyl group, a dibenzofuranyl group, a dibenzothiophenyl group, a benzocarbazolyl group, a dibenzocarbazolyl group, a dibenzosilolyl group, a pyridinyl group, -Si(Q₃₁)(Q₃₂)(Q₃₃), and -N(Q₃₁)(Q₃₂), and Q₃₁ to Q₃₃ may respectively be the same as defined above.

[0076] In one or more embodiments, in Formula 201, at least one selected from R₂₀₁ to R₂₀₃ may each independently be selected from:

a fluorenyl group, a spiro-bifluorenyl group, a carbazolyl group, a dibenzofuranyl group, and a dibenzothiophenyl group; and

a fluorenyl group, a spiro-bifluorenyl group, a carbazolyl group, a dibenzofuranyl group, and a dibenzothiophenyl group, each substituted with at least one selected from deuterium, -F, -Cl, -Br, -I, a hydroxyl group, a cyano group, a nitro group, an amidino group, a hydrazino group, a hydrazono group, a C₁-C₂₀ alkyl group, a C₁-C₂₀ alkoxy group, a cyclopentyl group, a cyclohexyl group, a cycloheptyl group, a cyclopentenyl group, a cyclohexenyl group, a phenyl group, a biphenyl group, a terphenyl group, a phenyl group substituted with a C₁-C₁₀ alkyl group, a phenyl group substituted with -F, a naphthyl group, a fluorenyl group, a spiro-bifluorenyl group, a carbazolyl group, a dibenzofuranyl group, and a dibenzothiophenyl group;

but embodiments of the present disclosure are not limited thereto.

[0077] In one or more embodiments, in Formula 202, i) R₂₀₁ and R₂₀₂ may be linked each other via a single bond, and/or ii) R₂₀₃ and R₂₀₄ may be linked each other via a single bond.

[0078] In one or more embodiments, in Formula 202, at least one selected from R₂₀₁ to R₂₀₄ may be selected from:

a carbazolyl group; and

a carbazolyl group substituted with at least one selected from deuterium, -F, -Cl, -Br, -I, a hydroxyl group, a cyano group, a nitro group, an amidino group, a hydrazino group, a hydrazono group, a C₁-C₂₀ alkyl group, a C₁-C₂₀ alkoxy group, a cyclopentyl group, a cyclohexyl group, a cycloheptyl group, a cyclopentenyl group, a cyclohexenyl group, a phenyl group, a biphenyl group, a terphenyl group, a phenyl group substituted with a C₁-C₁₀ alkyl group, a phenyl group substituted with -F, a naphthyl group, a fluorenyl group, a spiro-bifluorenyl group, a carbazolyl group, a dibenzofuranyl group, and a dibenzothiophenyl group;

but embodiments of the present disclosure are not limited thereto.

[0079] The compound represented by Formula 201 may be represented by Formula 201A:

Formula 201A

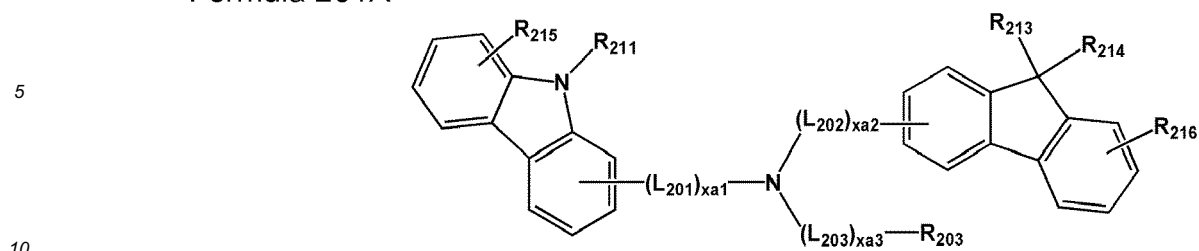

[0080] In one embodiment, the compound represented by Formula 201 may be represented by Formula 201A(1), but embodiments of the present disclosure are not limited thereto:

Formula 201A(1)

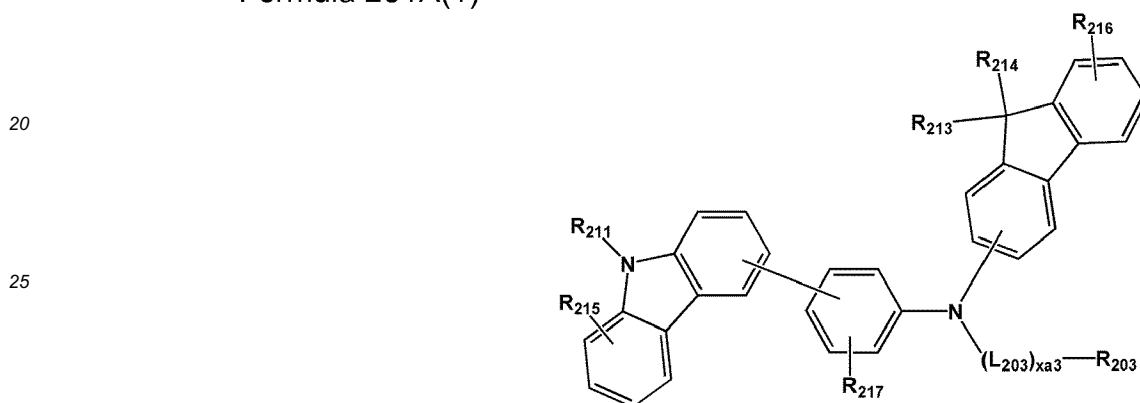

[0081] In one embodiment, the compound represented by Formula 201 may be represented by Formula 201A-1, but embodiments of the present disclosure are not limited thereto:

Formula 201A-1

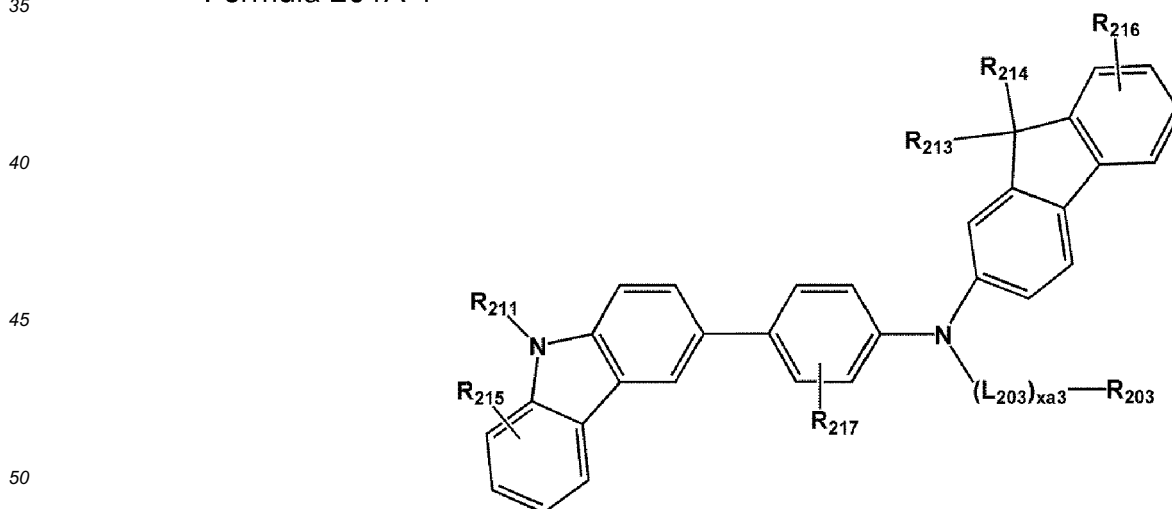

[0082] In one embodiment, the compound represented by Formula 202 may be represented by Formula 202A:

55

Formula 202A

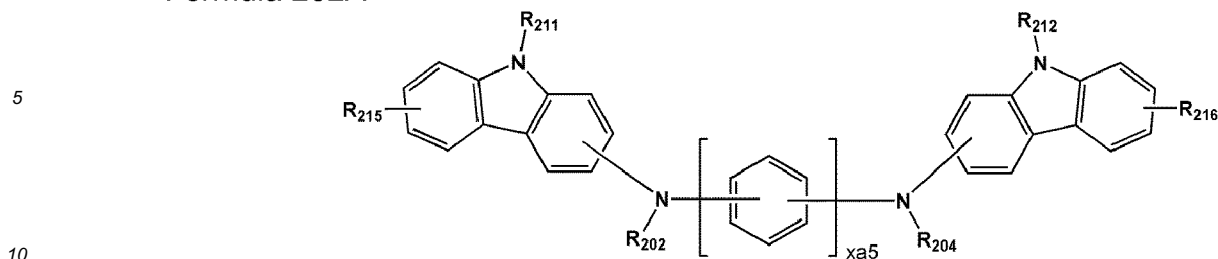

[0083] In one embodiment, the compound represented by Formula 202 may be represented by Formula 202A-1:

Formula 202A-1

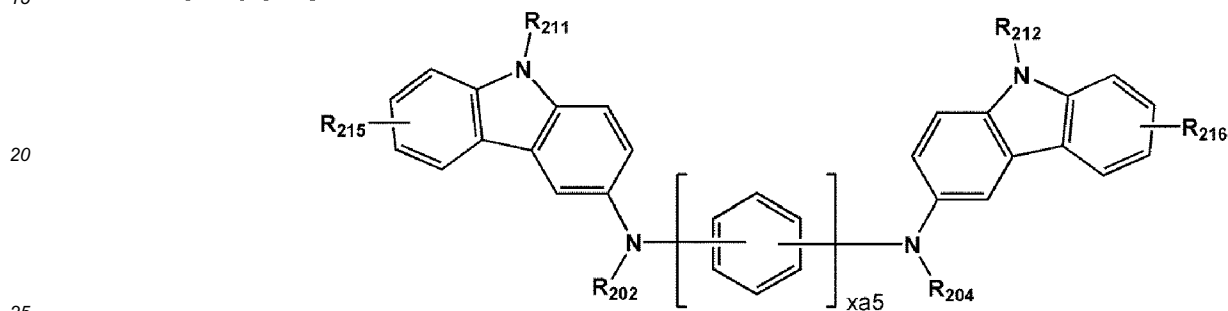

[0084] In Formulae 201A, 201A(1), 201A-1, 202A, and 202A-1,

L_{201} to L_{203} , $xa1$ to $xa3$, $xa5$, and R_{202} to R_{204} may respectively be the same as defined above,

R_{211} and R_{212} may respectively be the same as defined in connection with R_{203} .

R_{213} to R_{217} may each independently be selected from hydrogen, deuterium, -F, -Cl, -Br, -I, a hydroxyl group, a cyano group, a nitro group, an amidino group, a hydrazino group, a hydrazono group, a C_1 - C_{20} alkyl group, a C_1 - C_{20} alkoxy group, a cyclopentyl group, a cyclohexyl group, a cycloheptyl group, a cyclopentenyl group, a cyclohexenyl group, a phenyl group, a biphenyl group, a terphenyl group, a phenyl group substituted with a C_1 - C_{10} alkyl group, a phenyl group substituted with -F, a pentalenyl group, an indenyl group, a naphthyl group, an azulenyl group, a heptalenyl group, an indacenyl group, an acenaphthyl group, a fluorenyl group, a spiro-bifluorenyl group, a benzofluorenyl group, a dibenzofluorenyl group, a phenalenyl group, a phenanthrenyl group, an anthracenyl group, a fluoranthenyl group, a triphenylenyl group, a pyrenyl group, a chrysenyl group, a naphthacenyl group, a picenyl group, a perylenyl group, a pentaphenyl group, a hexacenyl group, a pentacenyl group, a rubicenyl group, a coronenyl group, an ovalenyl group, a thiophenyl group, a furanyl group, a carbazolyl group, an indolyl group, an isoindolyl group, a benzofuran group, a benzothiophenyl group, a dibenzofuran group, a dibenzothiophenyl group, a benzocarbazolyl group, a dibenzocarbazolyl group, a dibenzosilolyl group, and a pyridinyl group.

[0085] The hole transport region may include at least one compound selected from Compounds HT1 to HT39, but embodiments of the present disclosure are not limited thereto:

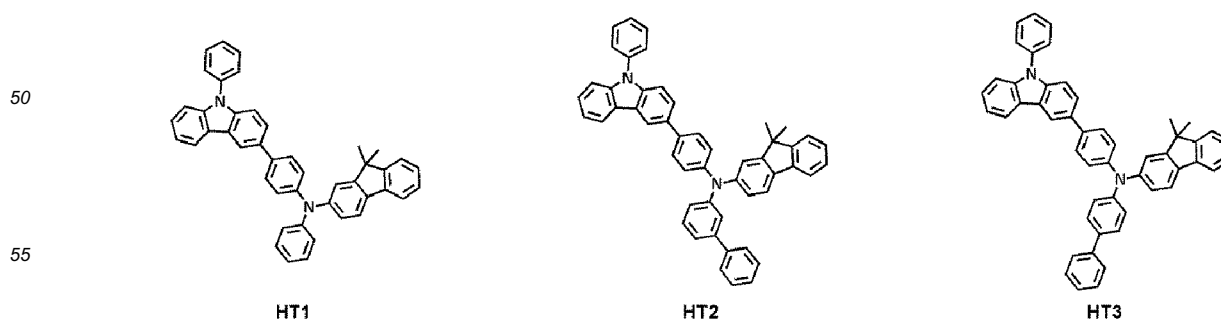

5

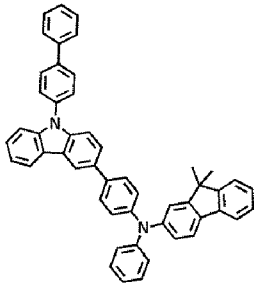

HT4

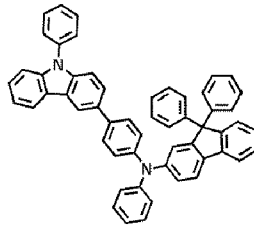

HT5

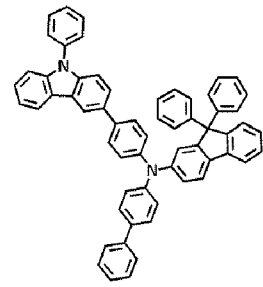

HT6

10

15

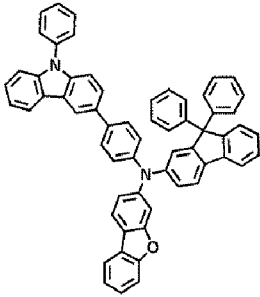

HT7

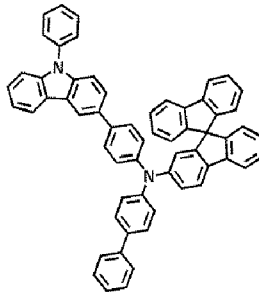

HT8

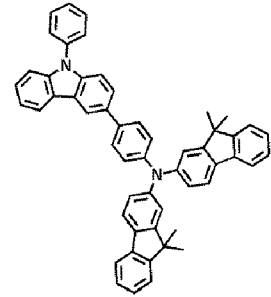

HT9

20

25

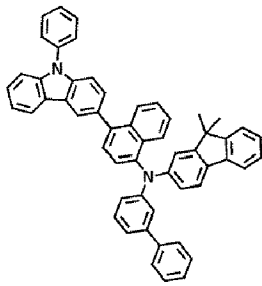

HT10

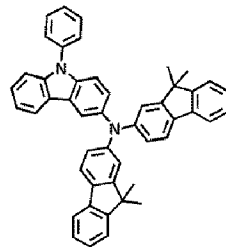

HT11

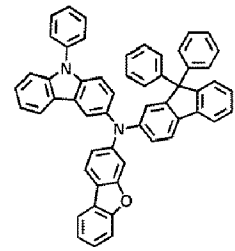

HT12

30

35

40

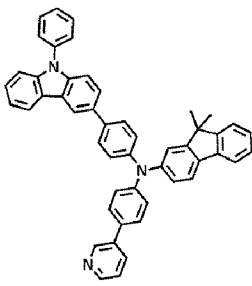

HT13

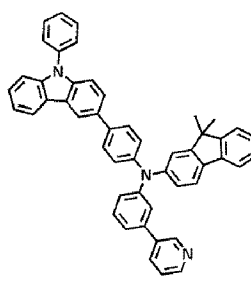

HT14

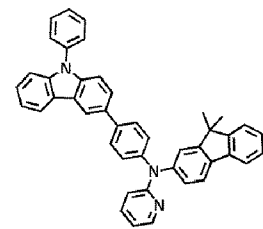

HT15

45

50

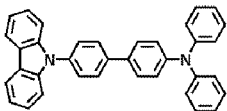

HT16

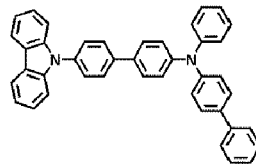

HT17

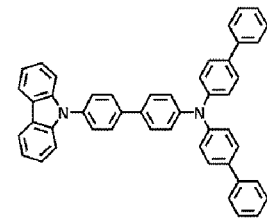

HT18

55

5

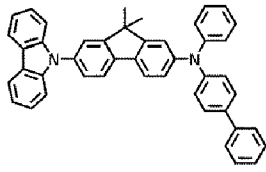

HT19

10

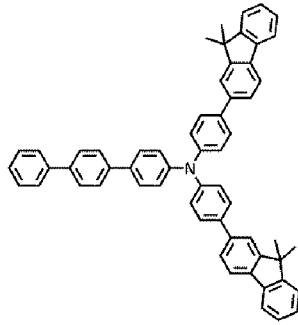

HT20

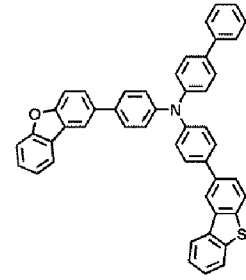

HT21

15

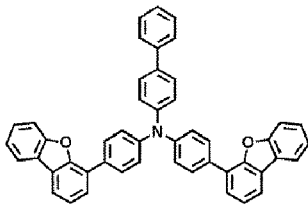

HT22

20

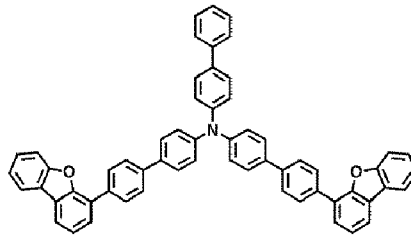

HT23

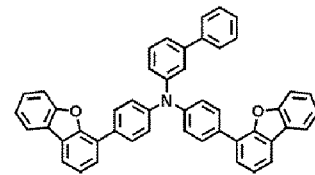

HT24

25

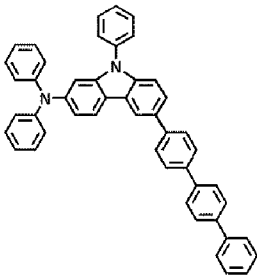

HT25

30

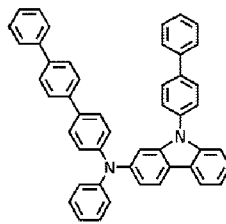

HT26

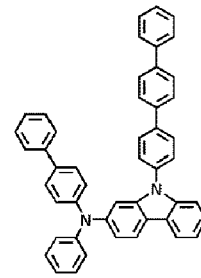

HT27

35

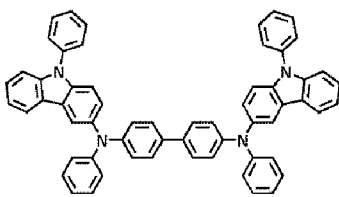

HT28

40

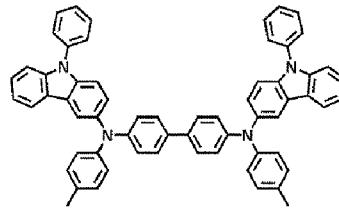

HT29

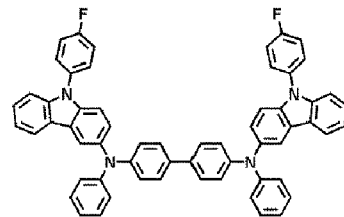

HT30

45

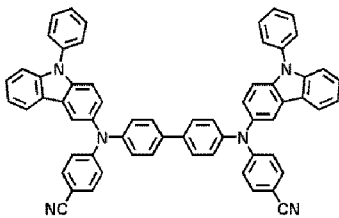

HT31

50

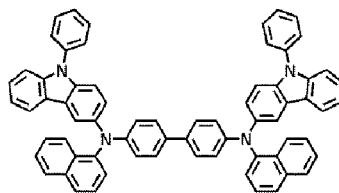

HT32

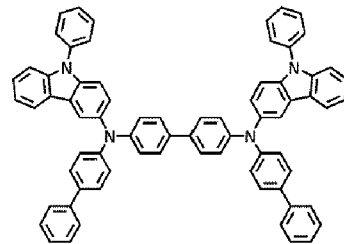

HT33

55

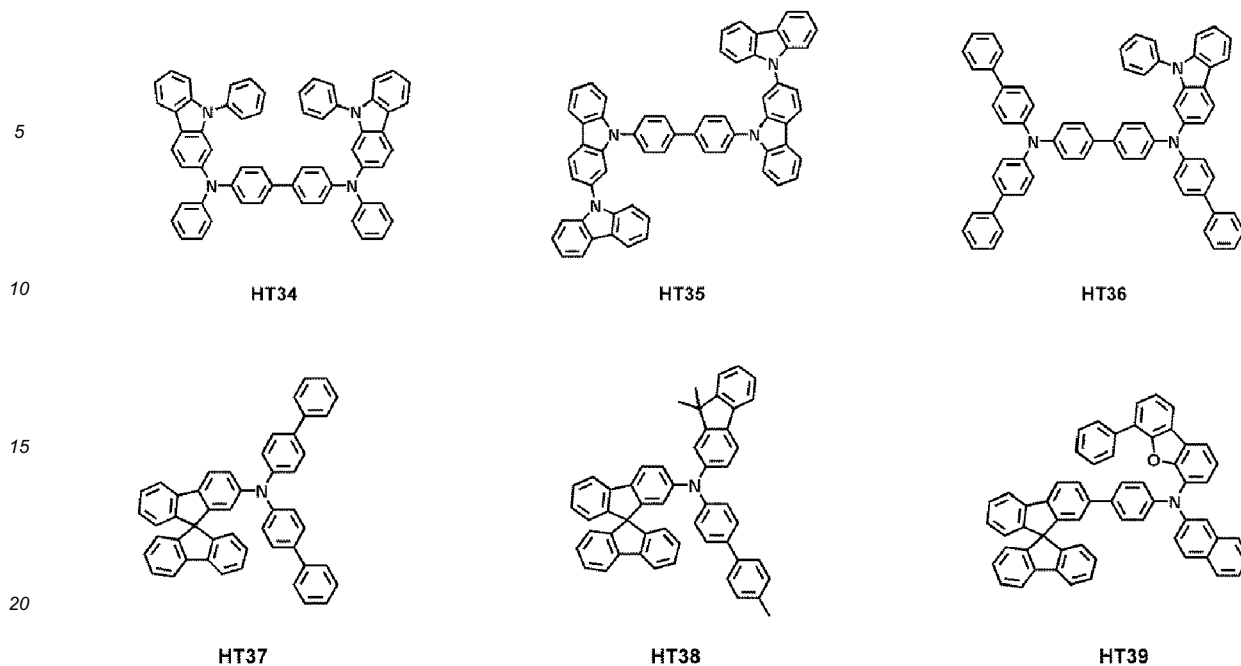

25 **[0086]** A thickness of the hole transport region may be in a range of about 100 Å to about 10,000 Å, for example, about 100 Å to about 7000 Å, about 100 Å to about 5000 Å, about 100 Å to about 3000 Å, or about 100 Å to about 1,000 Å. When the hole transport region includes at least one selected from a hole injection layer and a hole transport layer, the thickness of the hole injection layer may be in a range of about 100 Å to about 9,000 Å, and for example, about 100 Å to about 7,000 Å, about 100 Å to about 5,000 Å, about 100 Å to about 3,000 Å, about 100 Å to about 2,000 Å about 100 Å to about 1,000 Å or about 500 Å to about 700 Å, and the thickness of the hole transport layer may be in a range of

30 about 50 Å to about 2,000 Å, and for example, about 100 Å to about 1500 Å, about 100 Å to about 1,000 Å, about 100 Å to about 800 Å, about 100 Å to about 500 Å, or about 200 Å to about 400 Å. When the thicknesses of the hole transport region, the hole injection layer, and the hole transport layer are within these ranges, suitable or satisfactory hole transporting characteristics may be obtained without a substantial increase in driving voltage.

35 **[0087]** The emission auxiliary layer may increase light-emission efficiency by compensating for an optical resonance distance according to the wavelength of light emitted by an emission layer, and the electron blocking layer may block the flow of electrons from an electron transport region. The emission auxiliary layer and the electron blocking layer may include the materials as described above.

40 p-dopant

[0088] The hole transport region may further include, in addition to these materials, a charge-generation material for the improvement of conductive properties. The charge-generation material may be homogeneously or non-homogeneously dispersed in the hole transport region.

[0089] The charge-generation material may be, for example, a p-dopant.

45 **[0090]** In one embodiment, the p-dopant may have a lowest unoccupied molecular orbital (LUMO) level of -3.5 eV or less.

[0091] The p-dopant may include at least one selected from a quinone derivative, a metal oxide, and a cyano group-containing compound, but embodiments of the present disclosure are not limited thereto.

[0092] For example, the p-dopant may include at least one selected from:

50 a quinone derivative, such as tetracyanoquinodimethane (TCNQ) and 2,3,5,6-tetrafluoro-7,7,8,8-tetracyanoquinodimethane (F4-TCNQ); a metal oxide, such as tungsten oxide or molybdenum oxide; 1,4,5,8,9,11-hexaazatriphenylene-hexacarbonitrile (HAT-CN); and a compound represented by Formula 221,

55 but embodiments of the present disclosure are not limited thereto:

HAT-CN

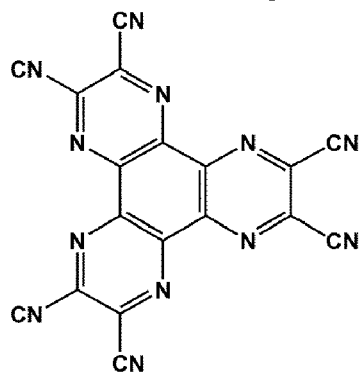

F4-TCNQ

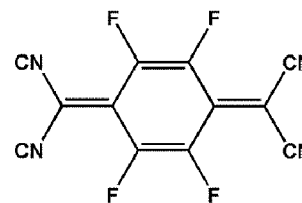

Formula 221

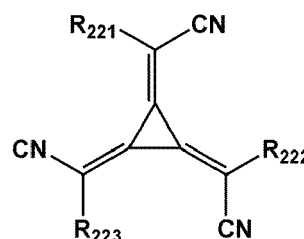

[0093] In Formula 221,

R_{221} to R_{223} may each independently be selected from a substituted or unsubstituted C_3 - C_{10} cycloalkyl group, a substituted or unsubstituted C_1 - C_{10} heterocycloalkyl group, a substituted or unsubstituted C_3 - C_{10} cycloalkenyl group, a substituted or unsubstituted C_1 - C_{10} heterocycloalkenyl group, a substituted or unsubstituted C_6 - C_{60} (e.g. C_6 - C_{32}) aryl group, a substituted or unsubstituted C_1 - C_{60} (e.g. C_1 - C_{20}) heteroaryl group, a substituted or unsubstituted monovalent non-aromatic condensed polycyclic group, and a substituted or unsubstituted monovalent non-aromatic condensed heteropolycyclic group, provided that at least one selected from R_{221} to R_{223} has at least one substituent selected from a cyano group, -F, -Cl, -Br, -I, a C_1 - C_{20} alkyl group substituted with -F, a C_1 - C_{20} alkyl group substituted with -Cl, a C_1 - C_{20} alkyl group substituted with -Br, and a C_1 - C_{20} alkyl group substituted with -I.

Emission layer in organic layer 150

[0094] When the organic light-emitting device 10 is a full-color organic light-emitting device, the emission layer may be patterned into a red emission layer, a green emission layer, or a blue emission layer, according to a sub-pixel. In one or more embodiments, the emission layer may have a stacked structure of two or more layers selected from a red emission layer, a green emission layer, and a blue emission layer, in which the two or more layers contact each other or are separated from each other. In one or more embodiments, the emission layer may include two or more materials selected from a red light-emitting material, a green light-emitting material, and a blue light-emitting material, in which the two or more materials are mixed with each other in a single layer to emit white light.

[0095] The emission layer may include a host and a dopant. The dopant may include at least one selected from a phosphorescent dopant and a fluorescent dopant.

[0096] In the emission layer, an amount of the dopant may be generally in a range of about 0.01 parts by weight to about 15 parts by weight based on 100 parts by weight of the host, but embodiments of the present disclosure are not limited thereto.

[0097] A thickness of the emission layer may be in a range of about 100 Å to about 1,000 Å, for example, about 100 Å to about 800 Å, about 150 Å to about 800 Å, about 150 Å to about 700 Å, about 150 Å to about 650 Å, about 200 Å to about 600 Å or about 200 Å to about 400 Å. When the thickness of the emission layer is within this range, excellent emission characteristics may be obtained without a substantial increase in driving voltage.

Host in emission layer

[0098] In one or more embodiments, the host may include a compound represented by Formula 301:

Formula 301

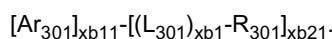

[0099] In Formula 301,

Ar₃₀₁ may be a substituted or unsubstituted C₅-C₆₀ carbocyclic group or a substituted or unsubstituted C₁-C₆₀ heterocyclic group,

xb11 may be 1, 2, or 3,

L₃₀₁ may be selected from a substituted or unsubstituted C₃-C₁₀ cycloalkylene group, a substituted or unsubstituted C₁-C₁₀ heterocycloalkylene group, a substituted or unsubstituted C₃-C₁₀ cycloalkenylene group, a substituted or unsubstituted C₁-C₁₀ heterocycloalkenylene group, a substituted or unsubstituted C₆-C₆₀ arylene group, a substituted or unsubstituted C₁-C₆₀ heteroarylene group, a substituted or unsubstituted divalent non-aromatic condensed polycyclic group, and a substituted or unsubstituted divalent non-aromatic condensed heteropolycyclic group;

xb1 may be an integer of 0 to 5,

R₃₀₁ may be selected from deuterium, -F, -Cl, -Br, -I, a hydroxyl group, a cyano group, a nitro group, an amidino group, a hydrazino group, a hydrazono group, a substituted or unsubstituted C₁-C₆₀ alkyl group, a substituted or unsubstituted C₂-C₆₀ alkenyl group, a substituted or unsubstituted C₂-C₆₀ alkynyl group, a substituted or unsubstituted C₁-C₆₀ alkoxy group, a substituted or unsubstituted C₃-C₁₀ cycloalkyl group, a substituted or unsubstituted C₁-C₁₀ heterocycloalkyl group, a substituted or unsubstituted C₃-C₁₀ cycloalkenyl group, a substituted or unsubstituted C₁-C₁₀ heterocycloalkenyl group, a substituted or unsubstituted C₆-C₆₀ aryl group, a substituted or unsubstituted C₆-C₆₀ aryloxy group, a substituted or unsubstituted C₆-C₆₀ arylthio group, a substituted or unsubstituted C₁-C₆₀ heteroaryl group, a substituted or unsubstituted monovalent non-aromatic condensed polycyclic group, a substituted or unsubstituted monovalent non-aromatic condensed heteropolycyclic group, -Si(Q₃₀₁)(Q₃₀₂)(Q₃₀₃), -N(Q₃₀₁)(Q₃₀₂), -B(Q₃₀₁)(Q₃₀₂), -C(=O)(Q₃₀₁), -S(=O)₂(Q₃₀₁), and -P(=O)(Q₃₀₁)(Q₃₀₂),

xb21 may be an integer of 1 to 5, and

Q₃₀₁ to Q₃₀₃ may each independently be selected from a C₁-C₁₀ alkyl group, a C₁-C₁₀ alkoxy group, a phenyl group, a biphenyl group, a terphenyl group, and a naphthyl group, but embodiments of the present disclosure are not limited thereto.

[0100] For example, Ar₃₀₁ may be a substituted or unsubstituted C₆-C₃₂ carbocyclic group or a substituted or unsubstituted C₁-C₁₂ heterocyclic group, but embodiments are not limited thereto.

[0101] In one embodiment, Ar₃₀₁ in Formula 301 may be selected from:

a naphthalene group, a fluorene group, a spiro-bifluorene group, a benzofluorene group, a dibenzofluorene group, a phenalene group, a phenanthrene group, an anthracene group, a fluoranthene group, a triphenylene group, a pyrene group, a chrysene group, a naphthacene group, a picene group, a perylene group, a pentaphene group, an indenoanthracene group, a dibenzofuran group, and a dibenzothiophene group; and

a naphthalene group, a fluorene group, a spiro-bifluorene group, a benzofluorene group, a dibenzofluorene group, a phenalene group, a phenanthrene group, an anthracene group, a fluoranthene group, a triphenylene group, a pyrene group, a chrysene group, a naphthacene group, a picene group, a perylene group, a pentaphene group, an indenoanthracene group, a dibenzofuran group, and a dibenzothiophene group, each substituted with at least one selected from deuterium, -F, -Cl, -Br, -I, a hydroxyl group, a cyano group, a nitro group, an amidino group, a hydrazino group, a hydrazono group, a C₁-C₂₀ alkyl group, a C₁-C₂₀ alkoxy group, a phenyl group, a biphenyl group, a terphenyl group, a naphthyl group, -Si(Q₃₁)(Q₃₂)(Q₃₃), -N(Q₃₁)(Q₃₂), -B(Q₃₁)(Q₃₂), -C(=O)(Q₃₁), -S(=O)₂(Q₃₁), and -P(=O)(Q₃₁)(Q₃₂), and

Q₃₁ to Q₃₃ may each independently be selected from a C₁-C₁₀ alkyl group, a C₁-C₁₀ alkoxy group, a phenyl group, a biphenyl group, a terphenyl group, and a naphthyl group, but embodiments of the present disclosure are not limited thereto.

[0102] In Formula 301, when xb11 is two or more, two or more of Ar₃₀₁(s) may be linked each other via a single bond.

[0103] In one or more embodiments, the compound represented by Formula 301 may be represented by Formula 301-1 or 301-2:

Formula 301-1

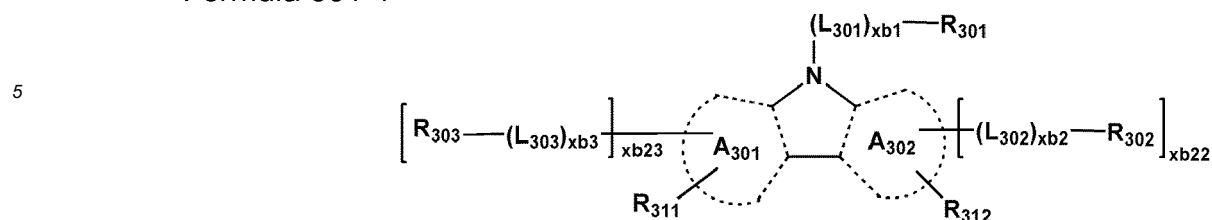

Formula 301-2

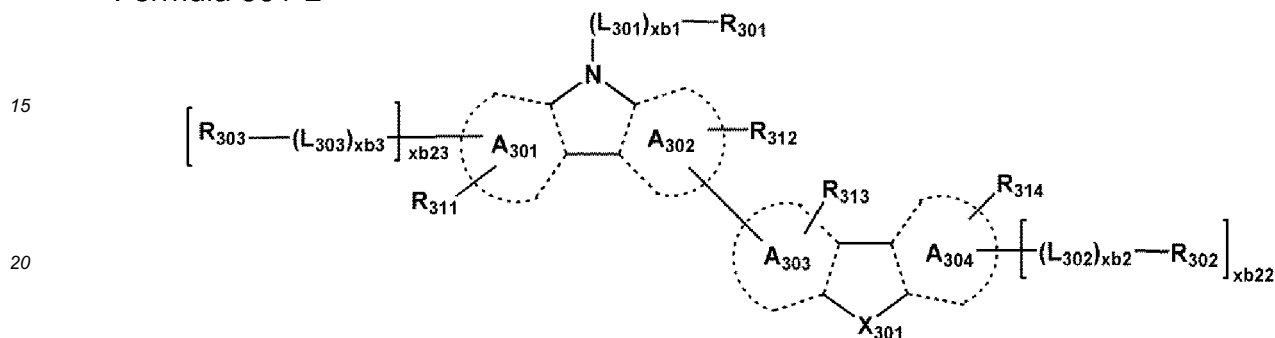

25 **[0104]** In Formulae 301-1 and 301-2,

A_{301} to A_{304} may each independently be selected from a benzene group, a naphthalene group, a phenanthrene group, a fluoranthene group, a triphenylene group, a pyrene group, a chrysene group, a pyridine group, a pyrimidine group, an indene group, a fluorene group, a spiro-bifluorene group, a benzofluorene group, a dibenzofluorene group, an indole group, a carbazole group, a benzocarbazole group, a dibenzocarbazole group, a furan group, a benzofuran group, a dibenzofuran group, a naphthofuran group, a benzonaphthofuran group, a dinaphthofuran group, a thiophene group, a benzothiophene group, a dibenzothiophene group, a naphthothiophene group, a benzonaphthothiophene group, and a dinaphthothiophene group,

X_{301} may be O, S, or N- $[(L_{304})_{xb4}-R_{304}]$,

R_{311} to R_{314} may each independently be selected from hydrogen, deuterium, -F, -Cl, -Br, -I, a hydroxyl group, a cyano group, a nitro group, an amidino group, a hydrazino group, a hydrazono group, a C_1 - C_{20} alkyl group, a C_1 - C_{20} alkoxy group, a phenyl group, a biphenyl group, a terphenyl group, a naphthyl group -Si(Q_{31})(Q_{32})(Q_{33}), -N(Q_{31})(Q_{32}), -B(Q_{31})(Q_{32}), -C(=O)(Q_{31}), -S(=O)₂(Q_{31}), and -P(=O)(Q_{31})(Q_{32}),

xb_{22} and xb_{23} may each independently be 0, 1, or 2,

L_{301} , xb_1 , R_{301} , and Q_{31} to Q_{33} may respectively be the same as defined above,

L_{302} to L_{304} may respectively be the same as defined in connection with L_{301} ,

xb_2 to xb_4 may respectively be the same as defined in connection with xb_1 , and

R_{302} to R_{304} may respectively be the same as defined in connection with R_{301} .

30 **[0105]** For example, L_{301} to L_{304} in Formulae 301, 301-1, and 301-2 may each independently be selected from: a substituted or unsubstituted C_3 - C_{10} cycloalkylene group, a substituted or unsubstituted C_1 - C_{10} heterocycloalkylene group, a substituted or unsubstituted C_3 - C_{10} cycloalkenylene group, a substituted or unsubstituted C_1 - C_{10} heterocycloalkenylene group, a substituted or unsubstituted C_6 - C_{30} arylene group, a substituted or unsubstituted C_1 - C_{20} heteroarylene group, a substituted or unsubstituted divalent non-aromatic condensed polycyclic group, and a substituted or unsubstituted divalent non-aromatic condensed heteropolycyclic group, but embodiments are not limited thereto.

35 **[0106]** For example, in Formulae 301, 301-1, and 301-2, L_{301} to L_{304} may each independently be selected from:

40 a phenylene group, a naphthylene group, a fluorenylene group, a spiro-bifluorenylene group, a benzofluorenylene group, a dibenzofluorenylene group, a phenanthrenylene group, an anthracenylenylene group, a fluoranthenylenylene group, a triphenylenylene group, a pyrenylene group, a chrysenylene group, a perylenylene group, a pentaphenylenylene group, a hexacenylenylene group, a pentacenylenylene group, a thiophenylenylene group, a furanylenylene group, a carbazolylene group, an indolylenylene group, an isoindolylenylene group, a benzofuranylenylene group, a benzothiophenylenylene group, a dibenzofuranylenylene group, a dibenzothiophenylenylene group, a benzocarbazolylene group, a dibenzocarbazolylene group, a dibenzosilolylenylene group, a pyridinylenylene group, an imidazolylene group, a pyrazolylene group, a thiazolylene group,

45

50

55

an isothiazolylene group, an oxazolylene group, an isoxazolylene group, a thiadiazolylene group, an oxadiazolylene group, a pyrazinylene group, a pyrimidinylene group, a pyridazinylene group, a triazinylene group, a quinolinylene group, an isoquinolinylene group, a benzoquinolinylene group, a phthalazinylene group, a naphthyridinylene group, a quinoxalinylene group, a quinazolinylene group, a cinnolinylene group, a phenanthridinylene group, an acridinylene group, a phenanthrolinylene group, a phenazinylene group, a benzimidazolylene group, an isobenzothiazolylene group, a benzoxazolylene group, an isobenzoxazolylene group, a triazolylene group, a tetrazolylene group, an imidazopyridinylene group, an imidazopyrimidinylene group, and an azacarbazolylene group; and
 a phenylene group, a naphthylene group, a fluorenylene group, a spiro-bifluorenylene group, a benzofluorenylene group, a dibenzofluorenylene group, a phenanthrenylene group, an anthracenylene group, a fluoranthenylene group, a triphenylenylene group, a pyrenylene group, a chrysenylene group, a perylenylene group, a pentaphenylene group, a hexacenylenylene group, a pentacenylenylene group, a thiophenylene group, a furanylene group, a carbazolylene group, an indolylene group, an isoindolylene group, a benzofuranylene group, a benzothiophenylene group, a dibenzofuranylene group, a dibenzothiophenylene group, a benzocarbazolylene group, a dibenzocarbazolylene group, a dibenzosilolylene group, a pyridinylene group, an imidazolylene group, a pyrazolylene group, a thiazolylene group, an isothiazolylene group, an oxazolylene group, an isoxazolylene group, a thiadiazolylene group, an oxadiazolylene group, a pyrazinylene group, a pyrimidinylene group, a pyridazinylene group, a triazinylene group, a quinolinylene group, an isoquinolinylene group, a benzoquinolinylene group, a phthalazinylene group, a naphthyridinylene group, a quinoxalinylene group, a quinazolinylene group, a cinnolinylene group, a phenanthridinylene group, a phenanthrolinylene group, a phenazinylene group, a benzimidazolylene group, an isobenzothiazolylene group, a benzoxazolylene group, an isobenzoxazolylene group, a triazolylene group, a tetrazolylene group, an imidazopyridinylene group, an imidazopyrimidinylene group, and an azacarbazolylene group, each substituted with at least one selected from deuterium, -F, -Cl, -Br, -I, a hydroxyl group, a cyano group, a nitro group, an amidino group, a hydrazino group, a hydrazono group, a C₁-C₂₀ alkyl group, a C₁-C₂₀ alkoxy group, a phenyl group, a biphenyl group, a terphenyl group, a naphthyl group, a fluorenyl group, a spiro-bifluorenyl group, a benzofluorenyl group, a dibenzofluorenyl group, a phenanthrenyl group, an anthracenyl group, a fluoranthenyl group, a triphenylenyl group, a pyrenyl group, a chrysenyl group, a perylenyl group, a pentaphenyl group, a hexacenylyl group, a pentacenylyl group, a thiophenyl group, a furanyl group, a carbazolyl group, an indolyl group, an isoindolyl group, a benzofuranyl group, a benzothiophenyl group, a dibenzofuranyl group, a dibenzothiophenyl group, a benzocarbazolyl group, a dibenzocarbazolyl group, a dibenzosilolyl group, a pyridinyl group, an imidazolyl group, a pyrazolyl group, a thiazolyl group, an isothiazolyl group, an oxazolyl group, an isoxazolyl group, a thiadiazolyl group, an oxadiazolyl group, a pyrazinyl group, a pyrimidinyl group, a pyridazinyl group, a triazinyl group, a quinolinyl group, an isoquinolinyl group, a benzoquinolinyl group, a phthalazinyl group, a naphthyridinyl group, a quinoxalinyl group, a quinazolinyl group, a cinnolinyl group, a phenanthridinyl group, an acridinyl group, a phenanthrolinyl group, a phenazinyl group, a benzimidazolyl group, an isobenzothiazolyl group, a benzoxazolyl group, an isobenzoxazolyl group, a triazolyl group, a tetrazolyl group, an imidazopyridinyl group, an imidazopyrimidinyl group, an azacarbazolyl group, -Si(Q₃₁)(Q₃₂)(Q₃₃), -N(Q₃₁)(Q₃₂), -B(Q₃₁)(Q₃₂), -C(=O)(Q₃₁), -S(=O)₂(Q₃₁), and -P(=O)(Q₃₁)(Q₃₂), and Q₃₁ and Q₃₃ may respectively be the same as defined above.

[0107] As another example, R₃₀₁ to R₃₀₄ in Formulae 301, 301-1, and 301-2 may each independently be selected from: deuterium, -F, -Cl, -Br, -I, a hydroxyl group, a cyano group, a nitro group, an amidino group, a hydrazino group, a hydrazono group, a substituted or unsubstituted C₁-C₆₀ (e.g. C₁-C₁₀) alkyl group, a substituted or unsubstituted C₂-C₆₀ (e.g. C₂-C₁₀) alkenyl group, a substituted or unsubstituted C₂-C₆₀ (e.g. C₂-C₁₀) alkynyl group, a substituted or unsubstituted C₁-C₆₀ (e.g. C₁-C₁₀) alkoxy group, a substituted or unsubstituted C₃-C₁₀ cycloalkyl group, a substituted or unsubstituted C₁-C₁₀ heterocycloalkyl group, a substituted or unsubstituted C₃-C₁₀ cycloalkenyl group, a substituted or unsubstituted C₁-C₁₀ heterocycloalkenyl group, a substituted or unsubstituted C₆-C₃₀ aryl group, a substituted or unsubstituted C₆-C₃₀ aryloxy group, a substituted or unsubstituted C₆-C₃₀ arylthio group, a substituted or unsubstituted C₁-C₂₀ heteroaryl group, a substituted or unsubstituted monovalent non-aromatic condensed polycyclic group, a substituted or unsubstituted monovalent non-aromatic condensed heteropolycyclic group, -Si(Q₃₀₁)(Q₃₀₂)(Q₃₀₃), -N(Q₃₀₁)(Q₃₀₂), -B(Q₃₀₁)(Q₃₀₂), -C(=O)(Q₃₀₁), -S(=O)₂(Q₃₀₁), and -P(=O)(Q₃₀₁)(Q₃₀₂), but embodiments are not limited thereto.

[0108] In one embodiment, in Formulae 301, 301-1, and 301-2, R₃₀₁ to R₃₀₄ may each independently be selected from:

a phenyl group, a biphenyl group, a terphenyl group, a naphthyl group, a fluorenyl group, a spiro-bifluorenyl group, a benzofluorenyl group, a dibenzofluorenyl group, a phenanthrenyl group, an anthracenyl group, a fluoranthenyl group, a triphenylenyl group, a pyrenyl group, a chrysenyl group, a perylenyl group, a pentaphenyl group, a hexacenylyl group, a pentacenylyl group, a thiophenyl group, a furanyl group, a carbazolyl group, an indolyl group, an isoindolyl group, a benzofuranyl group, a benzothiophenyl group, a dibenzofuranyl group, a dibenzothiophenyl group, a benzocarbazolyl group, a dibenzocarbazolyl group, a dibenzosilolyl group, a pyridinyl group, an imidazolyl group, a

pyrazolyl group, a thiazolyl group, an isothiazolyl group, an oxazolyl group, an isoxazolyl group, a thiadiazolyl group, an oxadiazolyl group, a pyrazinyl group, a pyrimidinyl group, a pyridazinyl group, a triazinyl group, a quinolinyl group, an isoquinolinyl group, a benzoquinolinyl group, a phthalazinyl group, a naphthyridinyl group, a quinoxalinyl group, a quinazolinyl group, a cinnolinyl group, a phenanthridinyl group, an acridinyl group, a phenanthrolinyl group, a phenazinyl group, a benzimidazolyl group, an isobenzothiazolyl group, a benzoxazolyl group, an isobenzoxazolyl group, a triazolyl group, a tetrazolyl group, an imidazopyridinyl group, an imidazopyrimidinyl group, and an azacarbazolyl group; and

a phenyl group, a biphenyl group, a terphenyl group, a naphthyl group, a fluorenyl group, a spiro-bifluorenyl group, a benzofluorenyl group, a dibenzofluorenyl group, a phenanthrenyl group, an anthracenyl group, a fluoranthenyl group, a triphenylenyl group, a pyrenyl group, a chrysenyl group, a perylenyl group, a pentaphenyl group, a hexacacenyl group, a pentacacenyl group, a thiophenyl group, a furanyl group, a carbazolyl group, an indolyl group, an isoindolyl group, a benzofuranyl group, a benzothiophenyl group, a dibenzofuranyl group, a dibenzothiophenyl group, a benzocarbazolyl group, a dibenzocarbazolyl group, a dibenzosilolyl group, a pyridinyl group, an imidazolyl group, a pyrazolyl group, a thiazolyl group, an isothiazolyl group, an oxazolyl group, an isoxazolyl group, a thiadiazolyl group, an oxadiazolyl group, a pyrazinyl group, a pyrimidinyl group, a pyridazinyl group, a triazinyl group, a quinolinyl group, an isoquinolinyl group, a benzoquinolinyl group, a phthalazinyl group, a naphthyridinyl group, a quinoxalinyl group, a quinazolinyl group, a cinnolinyl group, a phenanthridinyl group, an acridinyl group, a phenanthrolinyl group, a phenazinyl group, a benzimidazolyl group, an isobenzothiazolyl group, a benzoxazolyl group, an isobenzoxazolyl group, a triazolyl group, a tetrazolyl group, an imidazopyridinyl group, an imidazopyrimidinyl group, and an azacarbazolyl group, each substituted with at least one selected from deuterium, -F, -Cl, -Br, -I, a hydroxyl group, a cyano group, a nitro group, an amidino group, a hydrazino group, a hydrazono group, a C₁-C₂₀ alkyl group, a C₁-C₂₀ alkoxy group, a phenyl group, a biphenyl group, a terphenyl group, a naphthyl group, a fluorenyl group, a spiro-bifluorenyl group, a benzofluorenyl group, a dibenzofluorenyl group, a phenanthrenyl group, an anthracenyl group, a fluoranthenyl group, a triphenylenyl group, a pyrenyl group, a chrysenyl group, a perylenyl group, a pentaphenyl group, a hexacacenyl group, a pentacacenyl group, a thiophenyl group, a furanyl group, a carbazolyl group, an indolyl group, an isoindolyl group, a benzofuranyl group, a benzothiophenyl group, a dibenzofuranyl group, a dibenzothiophenyl group, a benzocarbazolyl group, a dibenzocarbazolyl group, a dibenzosilolyl group, a pyridinyl group, an imidazolyl group, a pyrazolyl group, a thiazolyl group, an isothiazolyl group, an oxazolyl group, an isoxazolyl group, a thiadiazolyl group, an oxadiazolyl group, a pyrazinyl group, a pyrimidinyl group, a pyridazinyl group, a triazinyl group, a quinolinyl group, an isoquinolinyl group, a benzoquinolinyl group, a phthalazinyl group, a naphthyridinyl group, a quinoxalinyl group, a quinazolinyl group, a cinnolinyl group, a phenanthridinyl group, an acridinyl group, a phenanthrolinyl group, a phenazinyl group, a benzimidazolyl group, an isobenzothiazolyl group, a benzoxazolyl group, an isobenzoxazolyl group, a triazolyl group, a tetrazolyl group, an imidazopyridinyl group, an imidazopyrimidinyl group, an azacarbazolyl group, -Si(Q₃₁)(Q₃₂)(Q₃₃), -N(Q₃₁)(Q₃₂), -B(Q₃₁)(Q₃₂), -C(=O)(Q₃₁), -S(=O)₂(Q₃₁), and -P(=O)(Q₃₁)(Q₃₂), and Q₃₁ and Q₃₃ may respectively be the same as defined above.

[0109] In one or more embodiments, the host may include an alkaline earth metal complex. For example, the host may include a complex selected from a Be complex (for example, Compound H55), a Mg complex, and a Zn complex. For example, the host may be selected from a Be complex (for example, Compound H55), a Mg complex, and a Zn complex.

[0110] The host may include at least one selected from 9,10-di(2-naphthyl)anthracene (ADN), 2-methyl-9,10-bis(naphthalen-2-yl)anthracene (MADN), 9,10-di(2-naphthyl)-2-t-butyl-anthracene (TBADN), 4,4'-bis(N-carbazolyl)-1,1'-biphenyl (CBP), 1,3-di-9-carbazolylbenzene (mCP), 1,3,5-tri(carbazol-9-yl)benzene (TCP), and Compounds H1 to H55, but embodiments of the present disclosure are not limited thereto:

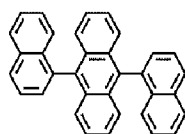

H1

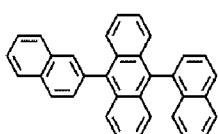

H2

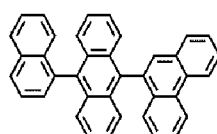

H3

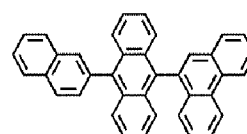

H4

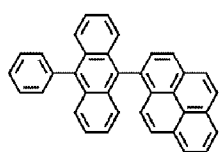

H5

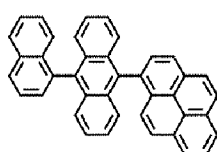

H6

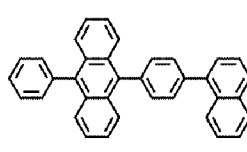

H7

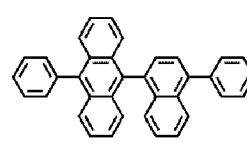

H8

5

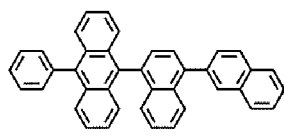

H9

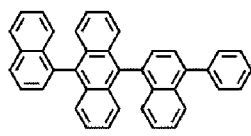

H10

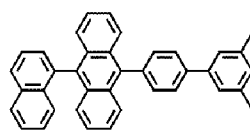

H11

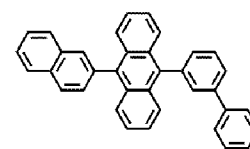

H12

10

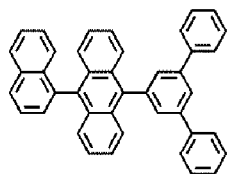

H13

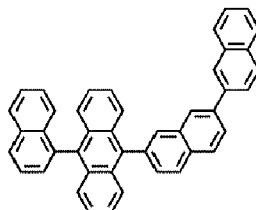

H14

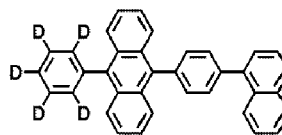

H15

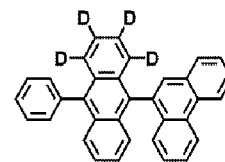

H16

15

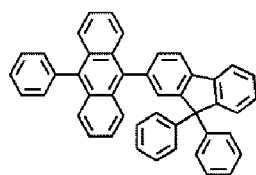

H17

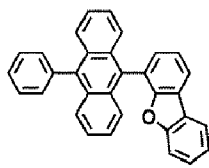

H18

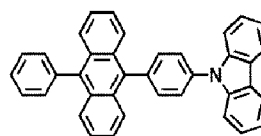

H19

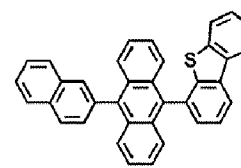

H20

20

25

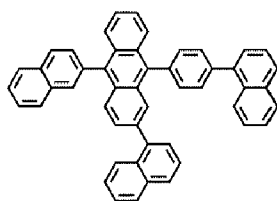

H21

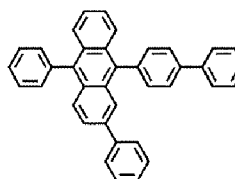

H22

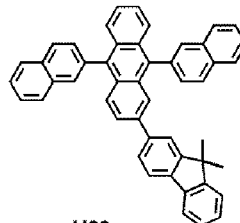

H23

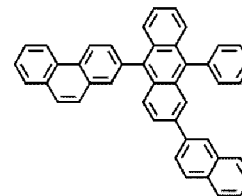

H24

30

35

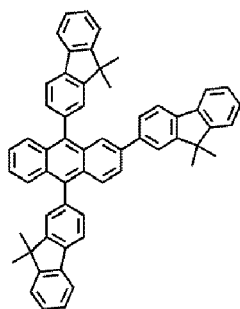

H25

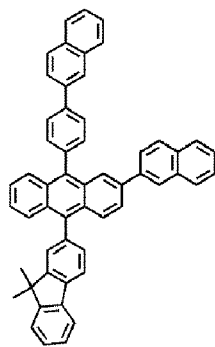

H26

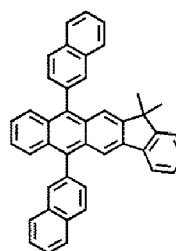

H27

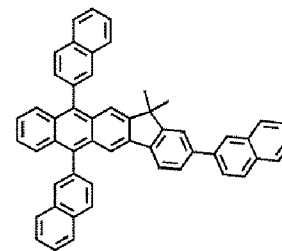

H28

40

45

50

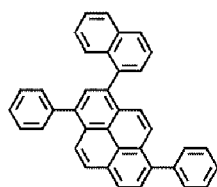

H29

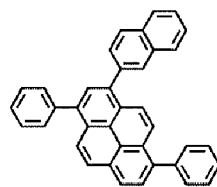

H30

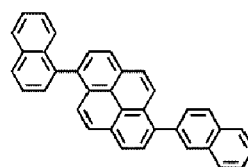

H31

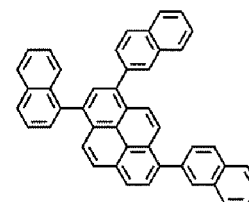

H32

55

5

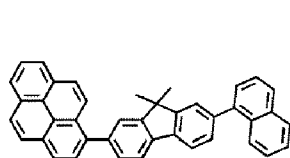

H33

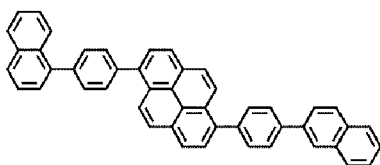

H34

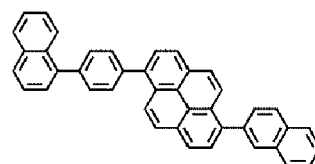

H35

10

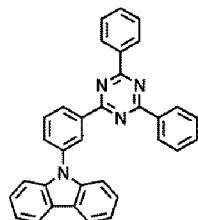

H36

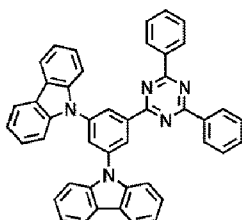

H37

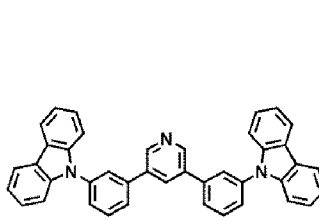

H38

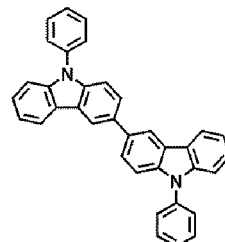

H39

15

20

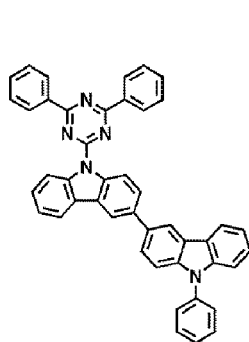

H40

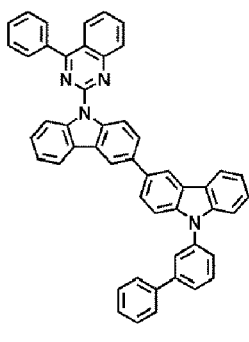

H41

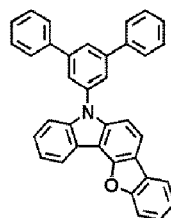

H42

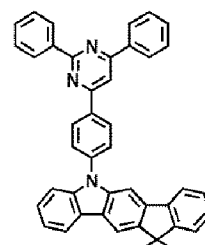

H43

25

30

35

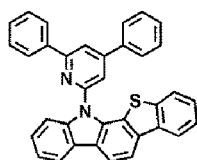

H44

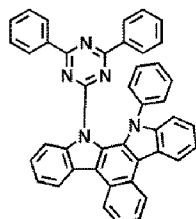

H45

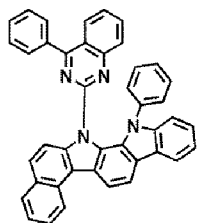

H46

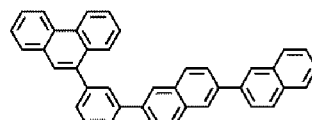

H47

40

45

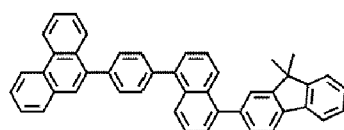

H48

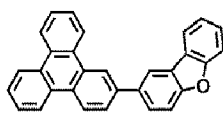

H49

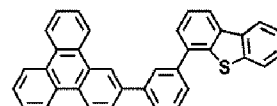

H50

50

55

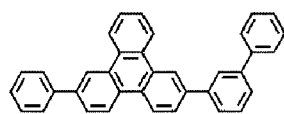

H51

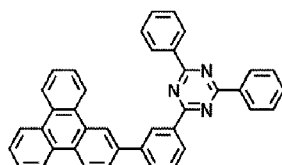

H52

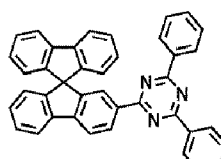

H53

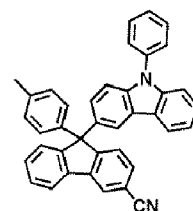

H54

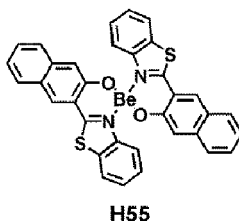

5

10 **[0111]** In one embodiment, the host may include at least one selected from a silicon-containing compound (for example, BCPDS used in the following examples or the like) and a phosphine oxide-containing compound (for example, POPCPA used in the following examples or the like).

15 **[0112]** However, embodiments of the present disclosure are not limited thereto. In one embodiment, the host may include only one compound, or two or more different compounds (for example, a host used in the following examples includes BCPDS and POPCPA).

Phosphorescent dopant included in emission layer in organic layer 150

20

[0113] The phosphorescent dopant may include an organometallic compound represented by Formula 1.

[Electron transport region in organic layer 150]

25

[0114] The electron transport region may have i) a single-layered structure including a single layer including a single material, ii) a single-layered structure including a single layer including a plurality of different materials, or iii) a multi-layered structure having a plurality of layers including a plurality of different materials.

[0115] The electron transport region may include at least one selected from a buffer layer, a hole blocking layer, an electron control layer, an electron transport layer, and an electron injection layer, but embodiments of the present disclosure are not limited thereto.

30

[0116] For example, the electron transport region may have an electron transport layer/electron injection layer structure, a hole blocking layer/electron transport layer/electron injection layer structure, an electron control layer/electron transport layer/electron injection layer structure, or a buffer layer/electron transport layer/electron injection layer structure, wherein for each structure, constituting layers are sequentially stacked from an emission layer. However, embodiments of the structure of the electron transport region are not limited thereto.

35

[0117] The electron transport region (for example, a buffer layer, a hole blocking layer, an electron control layer, or an electron transport layer in the electron transport region) may include a metal-free compound containing at least one π electron-depleted nitrogen-containing ring.

[0118] The term " π electron-depleted nitrogen-containing ring," as used herein, refers to a C_1 - C_{60} (e.g. C_1 - C_{30}) heterocyclic group having at least one $*-N=*$ moiety as a ring-forming moiety.

40

[0119] For example, the " π electron-depleted nitrogen-containing ring" may be i) a 5-membered to 7-membered heteromonocyclic group having at least one $*-N=*$ moiety, ii) a heteropolycyclic group in which two or more 5-membered to 7-membered heteromonocyclic groups each having at least one $*-N=*$ moiety are condensed with each other (e.g., combined together), or iii) a heteropolycyclic group in which at least one of 5-membered to 7-membered heteromonocyclic groups, each having at least one $*-N=*$ moiety, is condensed with (e.g., combined with) at least one C_5 - C_{60} (e.g. C_5 - C_{30}) carbocyclic group.

45

[0120] Examples of the π electron-depleted nitrogen-containing ring include an imidazole, a pyrazole, a thiazole, an isothiazole, an oxazole, an isoxazole, a pyridine, a pyrazine, a pyrimidine, a pyridazine, an indazole, a purine, a quinoline, an isoquinoline, a benzoquinoline, a phthalazine, a naphthyridine, a quinoxaline, a quinazoline, a cinnoline, a phenanthridine, an acridine, a phenanthroline, a phenazine, a benzimidazole, an isobenzothiazole, a benzoxazole, an isobenzoxazole, a triazole, a tetrazole, an oxadiazole, a triazine, thiadiazole, an imidazopyridine, an imidazopyrimidine, and an azacarbazole, but are not limited thereto.

50

[0121] For example, the electron transport region may include a compound represented by Formula 601:

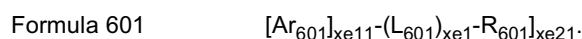

55

[0122] In Formula 601,

Ar_{601} may be a substituted or unsubstituted C_5 - C_{60} carbocyclic group or a substituted or unsubstituted C_1 - C_{60} heterocyclic group,

xe11 may be 1, 2, or 3,

L_{601} may each independently be selected from a substituted or unsubstituted C₃-C₁₀ cycloalkylene group, a substituted or unsubstituted C₁-C₁₀ heterocycloalkylene group, a substituted or unsubstituted C₃-C₁₀ cycloalkenylene group, a substituted or unsubstituted C₁-C₁₀ heterocycloalkenylene group, a substituted or unsubstituted C₆-C₆₀ arylene group, a substituted or unsubstituted C₁-C₆₀ heteroarylene group, a substituted or unsubstituted divalent non-aromatic condensed polycyclic group, and a substituted or unsubstituted divalent non-aromatic condensed heteropolycyclic group;

xe1 may be an integer of 0 to 5,

R_{601} may be selected from a substituted or unsubstituted C₃-C₁₀ cycloalkyl group, a substituted or unsubstituted C₁-C₁₀ heterocycloalkyl group, a substituted or unsubstituted C₃-C₁₀ cycloalkenyl group, a substituted or unsubstituted C₁-C₁₀ heterocycloalkenyl group, a substituted or unsubstituted C₆-C₆₀ aryl group, a substituted or unsubstituted C₆-C₆₀ aryloxy group, a substituted or unsubstituted C₆-C₆₀ arylthio group, a substituted or unsubstituted C₁-C₆₀ heteroaryl group, a substituted or unsubstituted monovalent non-aromatic condensed polycyclic group, a substituted or unsubstituted monovalent non-aromatic condensed heteropolycyclic group, -Si(Q₆₀₁)(Q₆₀₂)(Q₆₀₃), -C(=O)(Q₆₀₁), -S(=O)₂(Q₆₀₁), and -P(=O)(Q₆₀₁)(Q₆₀₂),

Q₆₀₁ to Q₆₀₃ may each independently be a C₁-C₁₀ alkyl group, a C₁-C₁₀ alkoxy group, a phenyl group, a biphenyl group, a terphenyl group, or a naphthyl group, and

xe21 may be an integer of 1 to 5.

[0123] In one embodiment, at least one of Ar₆₀₁(s) in the number of xe11 and R₆₀₁(s) in the number of xe21 may include the π electron-depleted nitrogen-containing ring.

[0124] For example, Ar₆₀₁ may be a substituted or unsubstituted C₅-C₃₀ carbocyclic group or a substituted or unsubstituted C₁-C₂₀ heterocyclic group, but embodiments are not limited thereto.

[0125] In one embodiment, ring Ar₆₀₁ in Formula 601 may be selected from:

a benzene group, a naphthalene group, a fluorene group, a spiro-bifluorene group, a benzofluorene group, a dibenzofluorene group, a phenalene group, a phenanthrene group, an anthracene group, a fluoranthene group, a triphenylene group, a pyrene group, a chrysene group, a naphthacene group, a picene group, a perylene group, a pentaphene group, an indenoanthracene group, a dibenzofuran group, a dibenzothiophene group, a carbazole group, an imidazole group, a pyrazole group, a thiazole group, an isothiazole group, an oxazole group, an isoxazole group, a pyridine group, a pyrazine group, a pyrimidine group, a pyridazine group, an indazole group, a purine group, a quinoline group, an isoquinoline group, a benzoquinoline group, a phthalazine group, a naphthyridine group, a quinoxaline group, a quinazoline group, a cinnoline group, a phenanthridine group, an acridine group, a phenanthroline group, a phenazine group, a benzimidazole group, an isobenzothiazole group, a benzoxazole group, an isobenzoxazole group, a triazole group, a tetrazole group, an oxadiazole group, a triazine group, a thiadiazole group, an imidazopyridine group, an imidazopyrimidine group, and an azacarbazole group; and

a benzene group, a naphthalene group, a fluorene group, a spiro-bifluorene group, a benzofluorene group, a dibenzofluorene group, a phenalene group, a phenanthrene group, an anthracene group, a fluoranthene group, a triphenylene group, a pyrene group, a chrysene group, a naphthacene group, a picene group, a perylene group, a pentaphene group, an indenoanthracene group, a dibenzofuran group, a dibenzothiophene group, a carbazole group, an imidazole group, a pyrazole group, a thiazole group, an isothiazole group, an oxazole group, an isoxazole group, a pyridine group, a pyrazine group, a pyrimidine group, a pyridazine group, an indazole group, a purine group, a quinoline group, an isoquinoline group, a benzoquinoline group, a phthalazine group, a naphthyridine group, a quinoxaline group, a quinazoline group, a cinnoline group, a phenanthridine group, an acridine group, a phenanthroline group, a phenazine group, a benzimidazole group, an isobenzothiazole group, a benzoxazole group, an isobenzoxazole group, a triazole group, a tetrazole group, an oxadiazole group, a triazine group, a thiadiazole group, an imidazopyridine group, an imidazopyrimidine group, and an azacarbazole group, each substituted with at least one selected from deuterium, -F, -Cl, -Br, -I, a hydroxyl group, a cyano group, a nitro group, an amidino group, a hydrazino group, a hydrazono group, a C₁-C₂₀ alkyl group, a C₁-C₂₀ alkoxy group, a phenyl group, a biphenyl group, a terphenyl group, a naphthyl group, -Si(Q₃₁)(Q₃₂)(Q₃₃), -S(=O)₂(Q₃₁), and -P(=O)(Q₃₁)(Q₃₂), and

Q₃₁ to Q₃₃ may each independently be selected from a C₁-C₁₀ alkyl group, a C₁-C₁₀ alkoxy group, a phenyl group, a biphenyl group, a terphenyl group, and a naphthyl group.

[0126] When xe11 in Formula 601 is two or more, two or more Ar₆₀₁(s) may be linked each other via a single bond.

[0127] In one or more embodiments, Ar₆₀₁ in Formula 601 may be an anthracene group.

[0128] In one or more embodiments, a compound represented by Formula 601 may be represented by Formula 601-1:

Formula 601-1

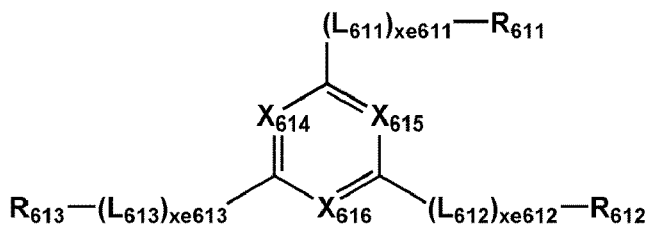

[0129] In Formula 601-1,

X_{614} may be N or C(R_{614}), X_{615} may be N or C(R_{615}), X_{616} may be N or C(R_{616}), and at least one selected from X_{614} to X_{616} may be N,

L_{611} to L_{613} may each independently be the same as described in connection with L_{601} ,

$xe611$ to $xe613$ may each independently be the same as described in connection with $xe1$,

R_{611} to R_{613} may each independently be the same as described in connection with R_{601} , and

R_{614} to R_{616} may each independently be selected from hydrogen, deuterium, -F, -Cl, -Br, -I, a hydroxyl group, a cyano group, a nitro group, an amidino group, a hydrazino group, a hydrazono group, a C_1 - C_{20} alkyl group, a C_1 - C_{20} alkoxy group, a phenyl group, a biphenyl group, a terphenyl group, and a naphthyl group.

[0130] For example, L_{601} and L_{611} to L_{613} in Formulae 601 and 601-1 may each independently be selected from: a substituted or unsubstituted C_3 - C_{10} cycloalkylene group, a substituted or unsubstituted C_1 - C_{10} heterocycloalkylene group, a substituted or unsubstituted C_3 - C_{10} cycloalkenylene group, a substituted or unsubstituted C_1 - C_{10} heterocycloalkenylene group, a substituted or unsubstituted C_6 - C_{30} arylene group, a substituted or unsubstituted C_1 - C_{20} heteroarylene group, a substituted or unsubstituted divalent non-aromatic condensed polycyclic group, and a substituted or unsubstituted divalent non-aromatic condensed heteropolycyclic group, but embodiments are not limited thereto.

[0131] In one embodiment, L_{601} and L_{611} to L_{613} in Formulae 601 and 601-1 may each independently be selected from:

a phenylene group, a naphthylene group, a fluorenylene group, a spiro-bifluorenylene group, a benzofluorenylene group, a dibenzofluorenylene group, a phenanthrenylene group, an anthracenylylene group, a fluoranthenylylene group, a triphenylylene group, a pyrenylene group, a chrysenylene group, a perylynylene group, a pentaphenylylene group, a hexacenylylene group, a pentacenylylene group, a thiophenylylene group, a furanylylene group, a carbazolylylene group, an indolylylene group, an isoindolylylene group, a benzofuranylylene group, a benzothiophenylylene group, a dibenzofuranylylene group, a dibenzothiophenylylene group, a benzocarbazolylylene group, a dibenzocarbazolylylene group, a dibenzosilolylylene group, a pyridinylylene group, an imidazolylylene group, a pyrazolylylene group, a thiazolylylene group, an isothiazolylylene group, an oxazolylylene group, an isoxazolylylene group, a thiadiazolylylene group, an oxadiazolylylene group, a pyrazinylylene group, a pyrimidinylylene group, a pyridazinylylene group, a triazinylylene group, a quinolinylene group, an isoquinolinylene group, a benzoquinolinylene group, a phthalazinylylene group, a naphthyridinylylene group, a quinoxalinylylene group, a quinazolinylene group, a cinnolinylene group, a phenanthridinylylene group, an acridinylylene group, a phenanthrolinylylene group, a phenazinylylene group, a benzimidazolylylene group, an isobenzothiazolylylene group, a benzoxazolylylene group, an isobenzoxazolylylene group, a triazolylylene group, a tetrazolylylene group, an imidazopyridinylylene group, an imidazopyrimidinylylene group, and an azacarbazolylylene group; and

a phenylene group, a naphthylene group, a fluorenylylene group, a spiro-bifluorenylylene group, a benzofluorenylylene group, a dibenzofluorenylylene group, a phenanthrenylene group, an anthracenylylene group, a fluoranthenylylene group, a triphenylylylene group, a pyrenylene group, a chrysenylene group, a perylynylylene group, a pentaphenylylene group, a hexacenylylene group, a pentacenylylene group, a thiophenylylene group, a furanylylene group, a carbazolylylene group, an indolylylene group, an isoindolylylene group, a benzofuranylylene group, a benzothiophenylylene group, a dibenzofuranylylene group, a dibenzothiophenylylene group, a benzocarbazolylylene group, a dibenzocarbazolylylene group, a dibenzosilolylylene group, a pyridinylylene group, an imidazolylylene group, a pyrazolylylene group, a thiazolylylene group, an isothiazolylylene group, an oxazolylylene group, an isoxazolylylene group, a thiadiazolylylene group, an oxadiazolylylene group, a pyrazinylylene group, a pyrimidinylylene group, a pyridazinylylene group, a triazinylylene group, a quinolinylene group, an isoquinolinylene group, a benzoquinolinylene group, a phthalazinylylene group, a naphthyridinylylene group, a quinoxalinylylene group, a quinazolinylene group, a cinnolinylene group, a phenanthridinylylene group, an acridinylylene group, a phenanthrolinylylene group, a phenazinylylene group, a benzimidazolylylene group, an isobenzothiazolylylene group, a benzoxazolylylene group, an isobenzoxazolylylene group, a triazolylylene group, a tetrazolylylene group, an imidazopyridinylylene group, an imidazopyrimidinylylene group, and an azacarbazolylylene group, each substituted with at least one selected from deuterium, -F, -Cl, -Br, -I, a hydroxyl group, a cyano group, a nitro group, an amidino

group, a hydrazino group, a hydrazono group, a C₁-C₂₀ alkyl group, a C₁-C₂₀ alkoxy group, a phenyl group, a biphenyl group, a terphenyl group, a naphthyl group, a fluorenyl group, a spiro-bifluorenyl group, a benzofluorenyl group, a dibenzofluorenyl group, a phenanthrenyl group, an anthracenyl group, a fluoranthenyl group, a triphenylenyl group, a pyrenyl group, a chrysenyl group, a perylenyl group, a pentaphenyl group, a hexacenyl group, a pentacenyl group, a thiophenyl group, a furanyl group, a carbazolyl group, an indolyl group, an isoindolyl group, a benzofuranyl group, a benzothiophenyl group, a dibenzofuranyl group, a dibenzothiophenyl group, a benzocarbazolyl group, a dibenzocarbazolyl group, a dibenzosilolyl group, a pyridinyl group, an imidazolyl group, a pyrazolyl group, a thiazolyl group, an isothiazolyl group, an oxazolyl group, an isoxazolyl group, a thiadiazolyl group, an oxadiazolyl group, a pyrazinyl group, a pyrimidinyl group, a pyridazinyl group, a triazinyl group, a quinolinyl group, an isoquinolinyl group, a benzoquinolinyl group, a phthalazinyl group, a naphthyridinyl group, a quinoxalinyl group, a quinazolinyl group, a cinnolinyl group, a phenanthridinyl group, an acridinyl group, a phenanthrolinyl group, a phenazinyl group, a benzimidazolyl group, an isobenzothiazolyl group, a benzoxazolyl group, an isobenzoxazolyl group, a triazolyl group, a tetrazolyl group, an imidazopyridinyl group, an imidazopyrimidinyl group, and an azacarbazolyl group; but embodiments of the present disclosure are not limited thereto.

[0132] In one or more embodiments, xe1 and xe611 to xe613 in Formulae 601 and 601-1 may each independently be 0, 1, or 2.

[0133] For example, R₆₀₁ and R₆₁₁ to R₆₁₃ in Formulae 601 and 601-1 may each independently be selected from: a substituted or unsubstituted C₃-C₁₀ cycloalkyl group, a substituted or unsubstituted C₁-C₁₀ heterocycloalkyl group, a substituted or unsubstituted C₃-C₁₀ cycloalkenyl group, a substituted or unsubstituted C₁-C₁₀ heterocycloalkenyl group, a substituted or unsubstituted C₆-C₃₀ aryl group, a substituted or unsubstituted C₆-C₃₀ aryloxy group, a substituted or unsubstituted C₆-C₃₀ arylthio group, a substituted or unsubstituted C₁-C₂₀ heteroaryl group, a substituted or unsubstituted monovalent non-aromatic condensed polycyclic group, a substituted or unsubstituted monovalent non-aromatic condensed heteropolycyclic group, -Si(Q₆₀₁)(Q₆₀₂)(Q₆₀₃), -C(=O)(Q₆₀₁), -S(=O)₂(Q₆₀₁), and -P(=O)(Q₆₀₁)(Q₆₀₂).

[0134] In one or more embodiments, in Formulae 601 and 601-1, R₆₀₁ and R₆₁₁ to R₆₁₃ may each independently be selected from:

a phenyl group, a biphenyl group, a terphenyl group, a naphthyl group, a fluorenyl group, a spiro-bifluorenyl group, a benzofluorenyl group, a dibenzofluorenyl group, a phenanthrenyl group, an anthracenyl group, a fluoranthenyl group, a triphenylenyl group, a pyrenyl group, a chrysenyl group, a perylenyl group, a pentaphenyl group, a hexacenyl group, a pentacenyl group, a thiophenyl group, a furanyl group, a carbazolyl group, an indolyl group, an isoindolyl group, a benzofuranyl group, a benzothiophenyl group, a dibenzofuranyl group, a dibenzothiophenyl group, a benzocarbazolyl group, a dibenzocarbazolyl group, a dibenzosilolyl group, a pyridinyl group, an imidazolyl group, a pyrazolyl group, a thiazolyl group, an isothiazolyl group, an oxazolyl group, an isoxazolyl group, a thiadiazolyl group, an oxadiazolyl group, a pyrazinyl group, a pyrimidinyl group, a pyridazinyl group, a triazinyl group, a quinolinyl group, an isoquinolinyl group, a benzoquinolinyl group, a phthalazinyl group, a naphthyridinyl group, a quinoxalinyl group, a quinazolinyl group, a cinnolinyl group, a phenanthridinyl group, an acridinyl group, a phenanthrolinyl group, a phenazinyl group, a benzimidazolyl group, an isobenzothiazolyl group, a benzoxazolyl group, an isobenzoxazolyl group, a triazolyl group, a tetrazolyl group, an imidazopyridinyl group, an imidazopyrimidinyl group, and an azacarbazolyl group;

a phenyl group, a biphenyl group, a terphenyl group, a naphthyl group, a fluorenyl group, a spiro-bifluorenyl group, a benzofluorenyl group, a dibenzofluorenyl group, a phenanthrenyl group, an anthracenyl group, a fluoranthenyl group, a triphenylenyl group, a pyrenyl group, a chrysenyl group, a perylenyl group, a pentaphenyl group, a hexacenyl group, a pentacenyl group, a thiophenyl group, a furanyl group, a carbazolyl group, an indolyl group, an isoindolyl group, a benzofuranyl group, a benzothiophenyl group, a dibenzofuranyl group, a dibenzothiophenyl group, a benzocarbazolyl group, a dibenzocarbazolyl group, a dibenzosilolyl group, a pyridinyl group, an imidazolyl group, a pyrazolyl group, a thiazolyl group, an isothiazolyl group, an oxazolyl group, an isoxazolyl group, a thiadiazolyl group, an oxadiazolyl group, a pyrazinyl group, a pyrimidinyl group, a pyridazinyl group, a triazinyl group, a quinolinyl group, an isoquinolinyl group, a benzoquinolinyl group, a phthalazinyl group, a naphthyridinyl group, a quinoxalinyl group, a quinazolinyl group, a cinnolinyl group, a phenanthridinyl group, an acridinyl group, a phenanthrolinyl group, a phenazinyl group, a benzimidazolyl group, an isobenzothiazolyl group, a benzoxazolyl group, an isobenzoxazolyl group, a triazolyl group, a tetrazolyl group, an imidazopyridinyl group, an imidazopyrimidinyl group, and an azacarbazolyl group, each substituted with at least one selected from deuterium, -F, -Cl, -Br, -I, a hydroxyl group, a cyano group, a nitro group, an amidino group, a hydrazino group, a hydrazono group, a C₁-C₂₀ alkyl group, a C₁-C₂₀ alkoxy group, a phenyl group, a biphenyl group, a terphenyl group, a naphthyl group, a fluorenyl group, a spiro-bifluorenyl group, a benzofluorenyl group, a dibenzofluorenyl group, a phenanthrenyl group, an anthracenyl group, a fluoranthenyl group, a triphenylenyl group, a pyrenyl group, a chrysenyl group, a perylenyl group, a pentaphenyl group, a hexacenyl group, a pentacenyl group, a thiophenyl group, a furanyl group, a carbazolyl group, an indolyl group, an

isindolyl group, a benzofuranyl group, a benzothiophenyl group, a dibenzofuranyl group, a dibenzothiophenyl group, a benzocarbazolyl group, a dibenzocarbazolyl group, a dibenzosilolyl group, a pyridinyl group, an imidazolyl group, a pyrazolyl group, a thiazolyl group, an isothiazolyl group, an oxazolyl group, an isoxazolyl group, a thiadiazolyl group, an oxadiazolyl group, a pyrazinyl group, a pyrimidinyl group, a pyridazinyl group, a triazinyl group, a quinolinyl group, an isoquinolinyl group, a benzoquinolinyl group, a phthalazinyl group, a naphthyridinyl group, a quinoxalinyl group, a quinazoliny group, a cinnolinyl group, a phenanthridinyl group, an acridinyl group, a phenanthrolinyl group, a phenaziny group, a benzimidazolyl group, an isobenzothiazolyl group, a benzoxazolyl group, an isobenzoxazolyl group, a triazolyl group, a tetrazolyl group, an imidazopyridinyl group, an imidazopyrimidinyl group, and an azacarbazolyl group; and

$-S(=O)_2(Q_{601})$ and $-P(=O)(Q_{601})(Q_{602})$, and Q_{601} and Q_{602} may respectively be the same as defined above.

[0135] The electron transport region may include at least one compound selected from Compounds ET1 to ET36, but embodiments of the present disclosure are not limited thereto:

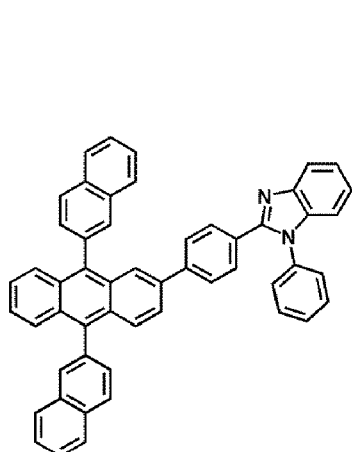

ET1

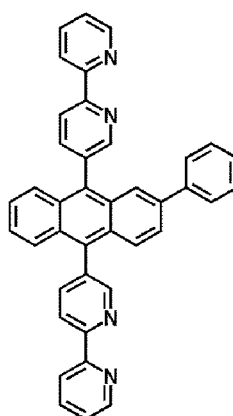

ET2

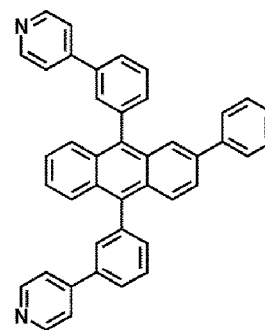

ET3

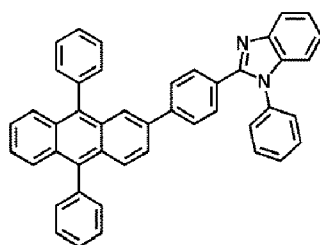

ET4

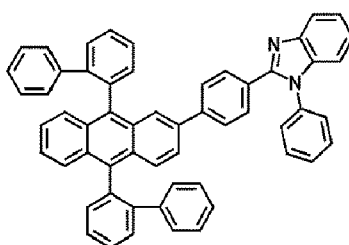

ET5

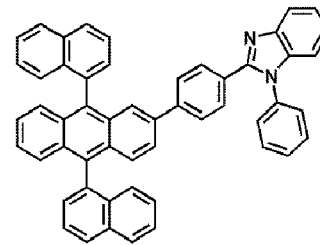

ET6

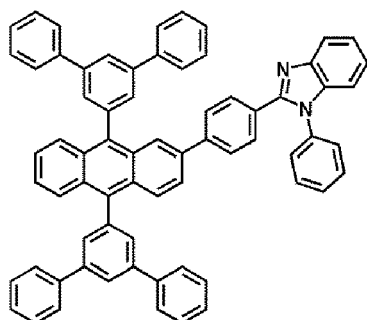

ET7

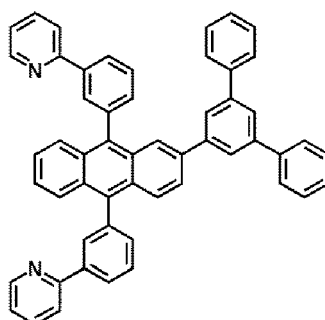

ET8

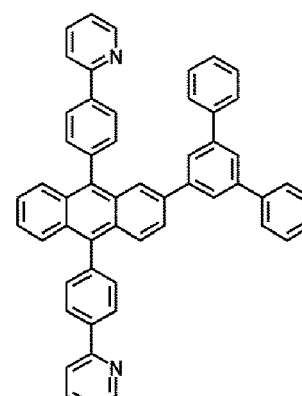

ET9

5

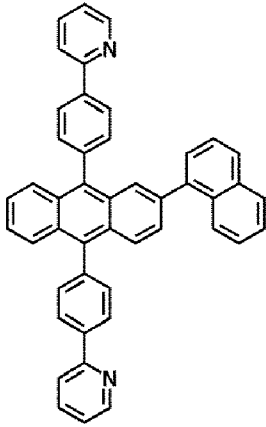

ET10

10

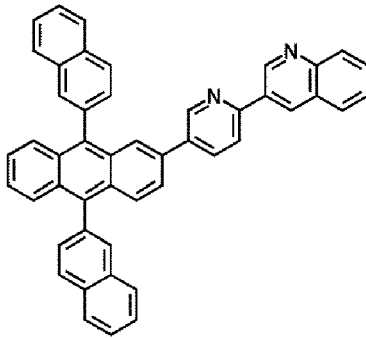

ET11

15

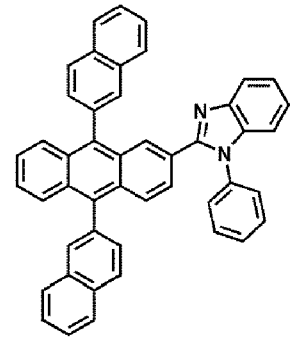

ET12

20

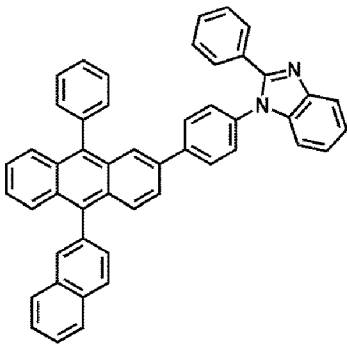

ET13

25

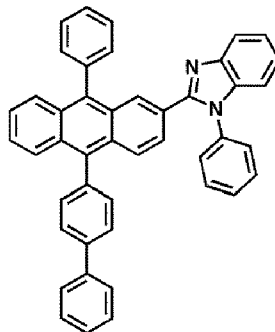

ET14

30

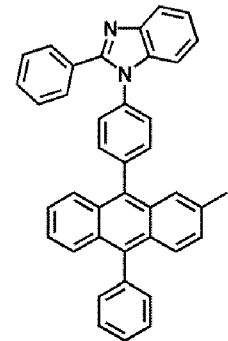

ET15

35

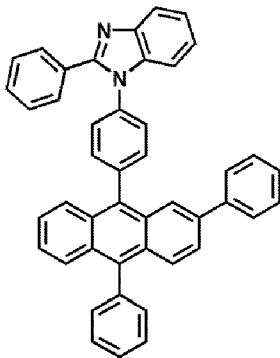

ET16

40

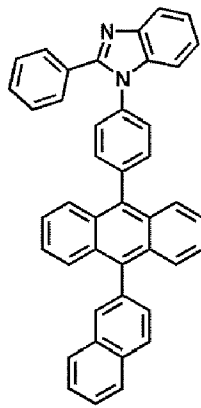

ET17

45

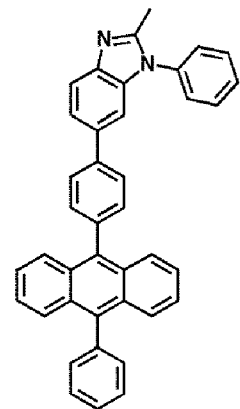

ET18

50

55

5

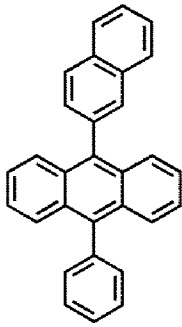

ET19

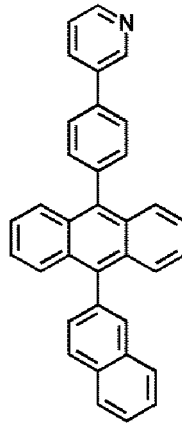

ET20

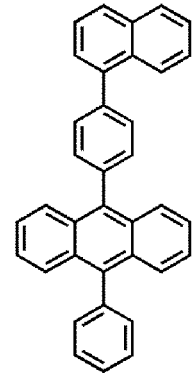

ET21

10

15

20

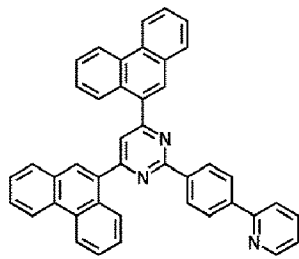

ET22

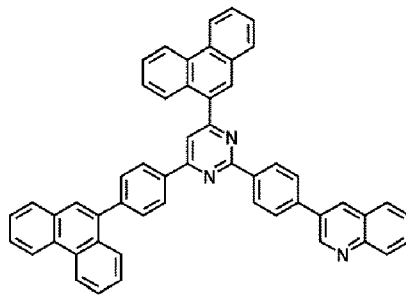

ET23

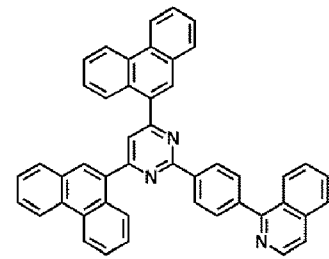

ET24

25

30

35

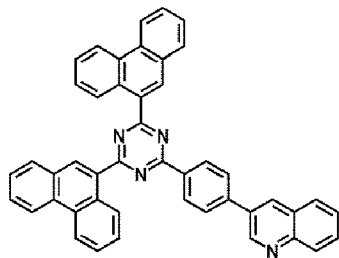

ET25

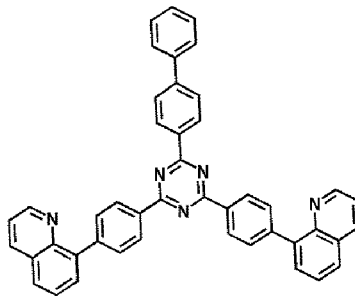

ET26

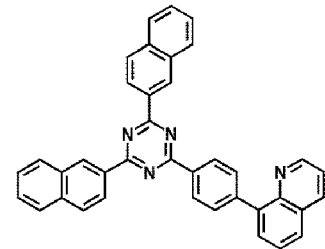

ET27

40

45

50

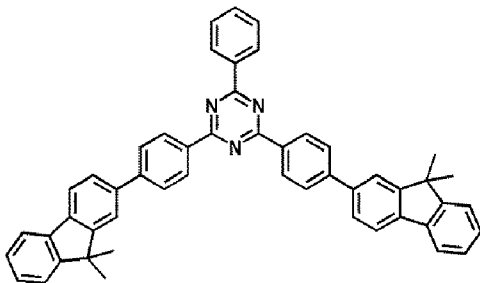

ET28

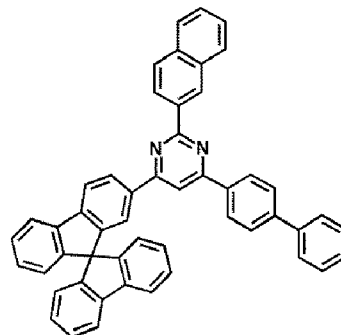

ET29

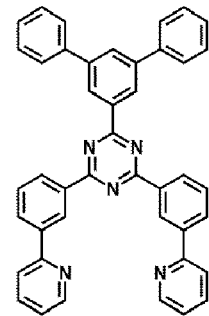

ET30

55

5

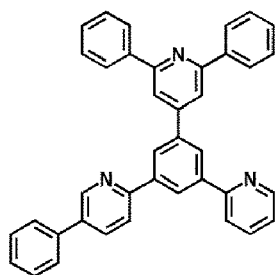

ET31

10

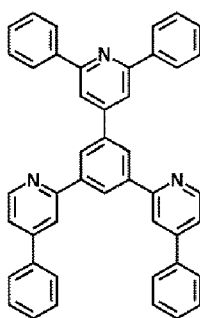

ET32

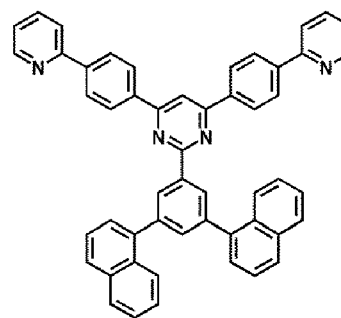

ET33

15

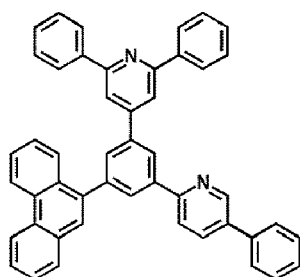

ET34

20

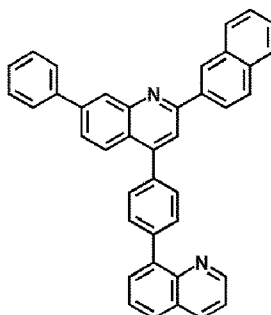

ET35

25

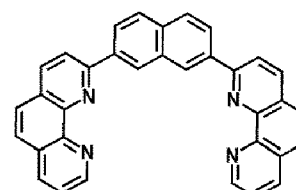

ET36

[0136] In one or more embodiments, the electron transport region may include at least one selected from 2,9-dimethyl-4,7-diphenyl-1,10-phenanthroline (BCP), 4,7-diphenyl-1,10-phenanthroline (Bphen), Alq₃, BAlq, 3-(biphenyl-4-yl)-5-(4-tert-butylphenyl)-4-phenyl-4H-1,2,4-triazole (TAZ), and NTAZ.

30

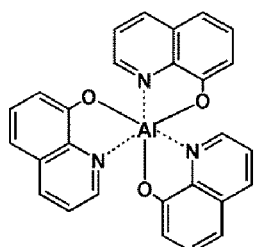
Alq₃

35

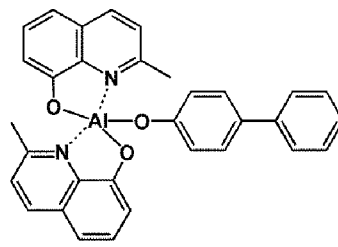

BAlq

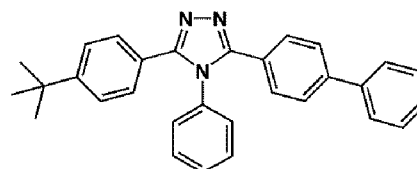

TAZ

40

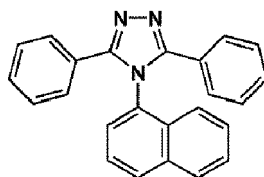

NTAZ

45

[0137] In one embodiment, the electron transport region may include a phosphine oxide-containing compound (for example, TSPO1 used in the following examples or the like), but embodiments of the present disclosure are not limited thereto. In one embodiment, the phosphine oxide-containing compound may be used in a hole blocking layer in the electron transport region, but embodiments of the present disclosure are not limited thereto.

50

[0138] Thicknesses of the buffer layer, the hole blocking layer, and the electron control layer may each be in a range of about 20 Å to about 1,000 Å, for example, about 20 Å to about 700 Å, about 20 Å to about 500 Å, about 20 Å to about 400 Å, about 30 Å to about 400 Å or about 30 Å to about 300 Å. When the thicknesses of the buffer layer, the hole blocking layer, and the electron control layer are within these ranges, the electron blocking layer may have excellent electron blocking characteristics or electron control characteristics without a substantial increase in driving voltage.

55

[0139] A thickness of the electron transport layer may be in a range of about 100 Å to about 1,000 Å, for example,

about 100 Å to about 700 Å, about 100 Å to about 600 Å, about 150 Å to about 600 Å, about 150 Å to about 500 Å or about 250 Å to about 350 Å. When the thickness of the electron transport layer is within the range described above, the electron transport layer may have suitable or satisfactory electron transport characteristics without a substantial increase in driving voltage.

[0140] The electron transport region (for example, the electron transport layer in the electron transport region) may further include, in addition to the materials described above, a metal-containing material.

[0141] The metal-containing material may include at least one selected from alkali metal complex and alkaline earth-metal complex. The alkali metal complex may include a metal ion selected from a Li ion, a Na ion, a K ion, a Rb ion, and a Cs ion, and the alkaline earth-metal complex may include a metal ion selected from a Be ion, a Mg ion, a Ca ion, a Sr ion, and a Ba ion. A ligand coordinated with the metal ion of the alkali metal complex or the alkaline earth-metal complex may be selected from a hydroxy quinoline, a hydroxy isoquinoline, a hydroxy benzoquinoline, a hydroxy acridine, a hydroxy phenanthridine, a hydroxy phenyloxazole, a hydroxy phenylthiazole, a hydroxy diphenyloxadiazole, a hydroxy diphenylthiadiazole, a hydroxy phenylpyridine, a hydroxy phenylbenzimidazole, a hydroxy phenylbenzothiazole, a bipyridine, a phenanthroline, and a cyclopentadiene, but embodiments of the present disclosure are not limited thereto.

[0142] For example, the metal-containing material may include a Li complex. The Li complex may include, for example, Compound ET-D1 (lithium quinolate, LiQ) or ET-D2:

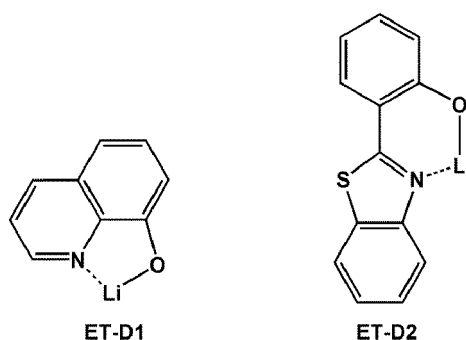

[0143] The electron transport region may include an electron injection layer that facilitates injection of electrons from the second electrode 190. The electron injection layer may directly contact the second electrode 190.

[0144] The electron injection layer may have i) a single-layered structure including a single layer including a single material, ii) a single-layered structure including a single layer including a plurality of different materials, or iii) a multi-layered structure having a plurality of layers including a plurality of different materials.

[0145] The electron injection layer may include an alkali metal, an alkaline earth metal, a rare earth metal, an alkali metal compound, an alkaline earth-metal compound, a rare earth metal compound, an alkali metal complex, an alkaline earth-metal complex, a rare earth metal complex, or any combinations thereof.

[0146] The alkali metal may be selected from Li, Na, K, Rb, and Cs. In one embodiment, the alkali metal may be Li, Na, or Cs. In one or more embodiments, the alkali metal may be Li or Cs, but embodiments of the present disclosure are not limited thereto.

[0147] The alkaline earth metal may be selected from Mg, Ca, Sr, and Ba.

[0148] The rare earth metal may be selected from Sc, Y, Ce, Tb, Yb, and Gd.

[0149] The alkali metal compound, the alkaline earth-metal compound, and the rare earth metal compound may be selected from oxides and halides (for example, fluorides, chlorides, bromides, or iodides) of the alkali metal, the alkaline earth-metal, and the rare earth metal.

[0150] The alkali metal compound may be selected from alkali metal oxides, such as Li_2O , Cs_2O , or K_2O , and alkali metal halides, such as LiF, NaF, CsF, KF, LiI, NaI, CsI, or KI. In one embodiment, the alkali metal compound may be selected from LiF, Li_2O , NaF, LiI, NaI, CsI, and KI, but embodiments of the present disclosure are not limited thereto.

[0151] The alkaline earth-metal compound may be selected from alkaline earth-metal oxides, such as BaO, SrO, CaO, $\text{Ba}_x\text{Sr}_{1-x}\text{O}$ ($0 < x < 1$), or $\text{Ba}_x\text{Ca}_{1-x}\text{O}$ ($0 < x < 1$). In one embodiment, the alkaline earth-metal compound may be selected from BaO, SrO, and CaO, but embodiments of the present disclosure are not limited thereto.

[0152] The rare earth metal compound may be selected from YbF_3 , ScF_3 , ScO_3 , Y_2O_3 , Ce_2O_3 , GdF_3 , and TbF_3 . In one embodiment, the rare earth metal compound may be selected from YbF_3 , ScF_3 , TbF_3 , YbI_3 , ScI_3 , and TbI_3 , but embodiments of the present disclosure are not limited thereto.

[0153] The alkali metal complex, the alkaline earth-metal complex, and the rare earth metal complex may include an ion of alkali metal, alkaline earth-metal, and rare earth metal as described above, and a ligand coordinated with a metal ion of the alkali metal complex, the alkaline earth-metal complex, or the rare earth metal complex may be selected from

hydroxy quinoline, hydroxy isoquinoline, hydroxy benzoquinoline, hydroxy acridine, hydroxy phenanthridine, hydroxy phenyloxazole, hydroxy phenylthiazole, hydroxy diphenyloxadiazole, hydroxy diphenylthiadiazole, hydroxy phenylpyridine, hydroxy phenylbenzimidazole, hydroxy phenylbenzothiazole, bipyridine, phenanthroline, and cyclopentadiene, but embodiments of the present disclosure are not limited thereto.

5 [0154] The electron injection layer may consist of an alkali metal, an alkaline earth metal, a rare earth metal, an alkali metal compound, an alkaline earth-metal compound, a rare earth metal compound, an alkali metal complex, an alkaline earth-metal complex, a rare earth metal complex, or any combinations thereof, as described above. In one or more embodiments, the electron injection layer may further include an organic material. When the electron injection layer further includes an organic material, an alkali metal, an alkaline earth metal, a rare earth metal, an alkali metal compound, 10 an alkaline earth-metal compound, a rare earth metal compound, an alkali metal complex, an alkaline earth-metal complex, a rare earth metal complex, or any combinations thereof may be homogeneously or non-homogeneously dispersed in a matrix including the organic material.

15 [0155] A thickness of the electron injection layer may be in a range of about 1 Å to about 100 Å, for example, about 3 Å to about 90 Å or about 3 Å to about 20 Å. When the thickness of the electron injection layer is within the range described above, the electron injection layer may have suitable or satisfactory electron injection characteristics without a substantial increase in driving voltage.

Second electrode 190

20 [0156] The second electrode 190 may be disposed on the organic layer 150 having such a structure. The second electrode 190 may be a cathode which is an electron injection electrode, and in this regard, a material for forming the second electrode 190 may be selected from metal, an alloy, an electrically conductive compound, and a combination thereof, which have a relatively low work function.

25 [0157] The second electrode 190 may include at least one selected from lithium (Li), silver (Ag), magnesium (Mg), aluminium (Al), aluminium-lithium (Al-Li), calcium (Ca), magnesium-indium (Mg-In), magnesium-silver (Mg-Ag), ITO, and IZO, but embodiments of the present disclosure are not limited thereto. The second electrode 190 may be a transmissive electrode, a semi-transmissive electrode, or a reflective electrode.

[0158] The second electrode 190 may have a single-layered structure, or a multi-layered structure including two or more layers.

30 [0159] Layers constituting the hole transport region, an emission layer, and layers constituting the electron transport region may be formed in a certain region by using one or more suitable methods selected from vacuum deposition, spin coating, casting, Langmuir-Blodgett (LB) deposition, ink-jet printing, laser-printing, and laser-induced thermal imaging.

35 [0160] When layers constituting the hole transport region, an emission layer, and layers constituting the electron transport region are formed by vacuum deposition, the deposition may be performed at a deposition temperature of about 100 °C to about 500 °C, a vacuum degree of about 10⁻⁸ torr to about 10⁻³ torr, and a deposition speed of about 0.01 Å/sec to about 100 Å/sec by taking into account a material to be included in a layer to be formed, and the structure of a layer to be formed.

40 [0161] When layers constituting the hole transport region, an emission layer, and layers constituting the electron transport region are formed by spin coating, the spin coating may be performed at a coating speed of about 2,000 rpm to about 5,000 rpm and at a heat treatment temperature of about 80 °C to about 200 °C by taking into account a material to be included in a layer to be formed, and the structure of a layer to be formed.

Apparatus

45 [0162] The organic light-emitting device may be included in various suitable apparatuses. For example, a light-emitting apparatus, an authentication apparatus, or an electronic apparatus, which includes the organic light-emitting device, may be provided.

50 [0163] The light-emitting apparatus may further include, in addition to the organic light-emitting device, a thin film transistor including a source electrode and a drain electrode. One of the source electrode and the drain electrode of the thin film transistor may be electrically coupled to (e.g., electrically connected to) one of the first electrode and the second electrode of the organic light-emitting device. The light-emitting apparatus may be used as various suitable displays, light sources, and the like.

[0164] The authentication apparatus may be, for example, a biometric authentication apparatus for authenticating an individual by using biometric information of a biometric body (for example, a fingertip, a pupil, or the like).

55 [0165] The authentication apparatus may further include, in addition to the organic light-emitting device, a biometric information collector.

[0166] The electronic apparatus may be applied to personal computers (for example, a mobile personal computer), mobile phones, digital cameras, electronic organizers, electronic dictionaries, electronic game machines, medical in-

struments (for example, electronic thermometers, sphygmomanometers, blood glucose meters, pulse measurement devices, pulse wave measurement devices, electrocardiogram (ECG) displays, ultrasonic diagnostic devices, or endoscope displays), fish finders, various suitable measuring instruments, meters (for example, meters for a vehicle, an aircraft, and a vessel), projectors, and the like, but embodiments of the present disclosure are not limited thereto.

5

General definition of some of the substituents

[0167] The term "C₁-C₆₀ alkyl group," as used herein, refers to a linear or branched aliphatic saturated hydrocarbon monovalent group having 1 to 60 carbon atoms, and examples thereof include a methyl group, an ethyl group, a propyl group, an isobutyl group, a sec-butyl group, a tert-butyl group, a pentyl group, an isoamyl group, and a hexyl group. The term "C₁-C₆₀ alkylene group," as used herein, refers to a divalent group having substantially the same structure as the C₁-C₆₀ alkyl group. Corresponding definitions apply to other ranges given for the number of carbon atoms in an alkyl/alkylene group.

[0168] The term "C₂-C₆₀ alkenyl group," as used herein, refers to a hydrocarbon group having at least one carbon-carbon double bond at a main chain (e.g., in the middle) or at a terminus of the C₂-C₆₀ alkyl group, and examples thereof include an ethenyl group, a propenyl group, and a butenyl group. The term "C₂-C₆₀ alkenylene group," as used herein, refers to a divalent group having substantially the same structure as the C₂-C₆₀ alkenyl group. Corresponding definitions apply to other ranges given for the number of carbon atoms in an alkenyl/alkenylene group.

[0169] The term "C₂-C₆₀ alkynyl group," as used herein, refers to a hydrocarbon group having at least one carbon-carbon triple bond at a main chain (e.g., in the middle) or at a terminus of the C₂-C₆₀ alkyl group, and examples thereof include an ethynyl group, and a propynyl group. The term "C₂-C₆₀ alkynylene group," as used herein, refers to a divalent group having substantially the same structure as the C₂-C₆₀ alkynyl group. Corresponding definitions apply to other ranges given for the number of carbon atoms in an alkynyl/alkynylene group.

[0170] The term "C₁-C₆₀ alkoxy group," as used herein, refers to a monovalent group represented by -OA₁₀₁ (wherein A₁₀₁ is the C₁-C₆₀ alkyl group), and examples thereof include a methoxy group, an ethoxy group, and an isopropoxy group. Corresponding definitions apply to other ranges given for the number of carbon atoms in an alkoxy group.

[0171] The term "C₃-C₁₀ cycloalkyl group," as used herein, refers to a monovalent saturated hydrocarbon monocyclic group having 3 to 10 carbon atoms, and examples thereof include a cyclopropyl group, a cyclobutyl group, a cyclopentyl group, a cyclohexyl group, and a cycloheptyl group. The term "C₃-C₁₀ cycloalkylene group," as used herein, refers to a divalent group having substantially the same structure as the C₃-C₁₀ cycloalkyl group.

[0172] The term "C₁-C₁₀ heterocycloalkyl group," as used herein, refers to a monovalent monocyclic group having at least one heteroatom selected from N, O, Si, P, and S as a ring-forming atom and 1 to 10 carbon atoms, and examples thereof include a 1,2,3,4-oxatriazolidinyl group, a tetrahydrofuranyl group, and a tetrahydrothiophenyl group. The term "C₁-C₁₀ heterocycloalkylene group," as used herein, refers to a divalent group having substantially the same structure as the C₁-C₁₀ heterocycloalkyl group.

[0173] The term "C₃-C₁₀ cycloalkenyl group," as used herein, refers to a monovalent monocyclic group that has 3 to 10 carbon atoms and at least one carbon-carbon double bond in the ring thereof and no aromaticity (e.g., the entire ring, group, or molecule is not aromatic), and examples thereof include a cyclopentenyl group, a cyclohexenyl group, and a cycloheptenyl group. The term "C₃-C₁₀ cycloalkenylene group," as used herein, refers to a divalent group having substantially the same structure as the C₃-C₁₀ cycloalkenyl group.

[0174] The term "C₁-C₁₀ heterocycloalkenyl group," as used herein, refers to a monovalent monocyclic group that has at least one heteroatom selected from N, O, Si, P, and S as a ring-forming atom, 1 to 10 carbon atoms, and at least one carbon-carbon double bond in its ring. Non-limiting examples of the C₁-C₁₀ heterocycloalkenyl group include a 4,5-dihydro-1,2,3,4-oxatriazolyl group, a 2,3-dihydrofuranyl group, and a 2,3-dihydrothiophenyl group. The term "C₁-C₁₀ heterocycloalkenylene group," as used herein, refers to a divalent group having substantially the same structure as the C₁-C₁₀ heterocycloalkenyl group.

[0175] The term "C₆-C₆₀ aryl group," as used herein, refers to a monovalent group having a carbocyclic aromatic system having 6 to 60 carbon atoms, and the term "C₆-C₆₀ arylene group," as used herein, refers to a divalent group having a carbocyclic aromatic system having 6 to 60 carbon atoms. Non-limiting examples of the C₆-C₆₀ aryl group include a phenyl group, a naphthyl group, an anthracenyl group, a phenanthrenyl group, a pyrenyl group, and a chrysenyl group. When the C₆-C₆₀ aryl group and the C₆-C₆₀ arylene group each include two or more rings, the rings may be fused to each other (e.g., combined together). Corresponding definitions apply to other ranges given for the number of carbon atoms in an aryl/arylene group.

[0176] The term "C₁-C₆₀ heteroaryl group," as used herein, refers to a monovalent group having a carbocyclic aromatic system that has at least one heteroatom selected from N, O, Si, P, and S as a ring-forming atom, in addition to 1 to 60 carbon atoms. The term "C₁-C₆₀ heteroarylene group," as used herein, refers to a divalent group having a carbocyclic aromatic system that has at least one heteroatom selected from N, O, Si, P, and S as a ring-forming atom, in addition to 1 to 60 carbon atoms. Non-limiting examples of the C₁-C₆₀ heteroaryl group include a pyridinyl group, a pyrimidinyl

group, a pyrazinyl group, a pyridazinyl group, a triazinyl group, a quinolinyl group, and an isoquinolinyl group. When the C₁-C₆₀ heteroaryl group and the C₁-C₆₀ heteroarylene group each include two or more rings, the rings may be condensed with each other (e.g., combined together). Corresponding definitions apply to other ranges given for the number of carbon atoms in an heteroaryl/heteroarylene group.

[0177] The term "C₆-C₆₀ aryloxy group," as used herein, refers to -OA₁₀₂ (wherein A₁₀₂ is the C₆-C₆₀ aryl group), and the term "C₆-C₆₀ arylthio group," as used herein, indicates -SA₁₀₃ (wherein A₁₀₃ is the C₆-C₆₀ aryl group). Corresponding definitions apply to other ranges given for the number of carbon atoms in an aryloxy group and an arylthio group.

[0178] The term "monovalent non-aromatic condensed polycyclic group," as used herein, refers to a monovalent group (for example, having 8 to 60 carbon atoms) having two or more rings condensed with each other (e.g., combined together), only carbon atoms as ring-forming atoms, and no aromaticity in its entire molecular structure (e.g., the entire group or molecule is not aromatic). An example of the monovalent non-aromatic condensed polycyclic group is a fluorenyl group. The term "divalent non-aromatic condensed polycyclic group," as used herein, refers to a divalent group having substantially the same structure as the monovalent non-aromatic condensed polycyclic group.

[0179] The term "monovalent non-aromatic condensed heteropolycyclic group," as used herein, refers to a monovalent group (for example, having 1 to 60 carbon atoms) having two or more rings condensed to each other (e.g., combined together), at least one heteroatom selected from N, O, Si, P, and S, other than carbon atoms, as a ring-forming atom, and no aromaticity in its entire molecular structure (the entire group or molecule is not aromatic). An example of the monovalent non-aromatic condensed heteropolycyclic group is a carbazolyl group. The term "divalent non-aromatic condensed heteropolycyclic group," as used herein, refers to a divalent group having substantially the same structure as the monovalent non-aromatic condensed heteropolycyclic group.

[0180] The term "C₅-C₆₀ carbocyclic group," as used herein, refers to a monocyclic or polycyclic group having 5 to 60 carbon atoms in which a ring-forming atom is a carbon atom only. The C₅-C₆₀ carbocyclic group may be an aromatic carbocyclic group or a non-aromatic carbocyclic group. The C₅-C₆₀ carbocyclic group may be a ring, such as benzene, a monovalent group, such as a phenyl group, or a divalent group, such as a phenylene group. In one or more embodiments, depending on the number of substituents coupled to (e.g., connected to) the C₅-C₆₀ carbocyclic group, the C₅-C₆₀ carbocyclic group may be a trivalent group or a quadrivalent group.

[0181] The term "C₁-C₆₀ heterocyclic group," as used herein, refers to a group having substantially the same structure as the C₅-C₆₀ carbocyclic group, except that as a ring-forming atom, at least one heteroatom selected from N, O, Si, P, and S is used in addition to carbon (the number of carbon atoms may be in a range of 1 to 60).

[0182] In the present disclosure, at least one substituent of the substituted C₅-C₆₀ (e.g. C₅-C₃₀) carbocyclic group, the substituted C₁-C₆₀ (e.g. C₁-C₂₀) heterocyclic group, the substituted C₃-C₁₀ cycloalkylene group, the substituted C₁-C₁₀ heterocycloalkylene group, the substituted C₃-C₁₀ cycloalkenylene group, the substituted C₁-C₁₀ heterocycloalkenylene group, the substituted C₆-C₆₀ (e.g. C₆-C₃₀) arylene group, the substituted C₁-C₆₀ (e.g. C₁-C₂₀) heteroarylene group, substituted divalent non-aromatic condensed polycyclic group, substituted divalent non-aromatic condensed heteropolycyclic group, the substituted C₁-C₆₀ (e.g. C₁-C₂₀) alkyl group, the substituted C₂-C₆₀ (e.g. C₂-C₂₀) alkenyl group, the substituted C₂-C₆₀ (e.g. C₂-C₂₀) alkynyl group, the substituted C₁-C₆₀ (e.g. C₁-C₂₀) alkoxy group, the substituted C₃-C₁₀ cycloalkyl group, the substituted C₁-C₁₀ heterocycloalkyl group, the substituted C₃-C₁₀ cycloalkenyl group, the substituted C₁-C₁₀ heterocycloalkenyl group, the substituted C₆-C₆₀ (e.g. C₆-C₃₀) aryl group, the substituted C₆-C₆₀ (e.g. C₆-C₃₀) aryloxy group, the substituted C₆-C₆₀ (e.g. C₆-C₃₀) arylthio group, the substituted C₁-C₆₀ (e.g. C₁-C₂₀) heteroaryl group, substituted monovalent non-aromatic condensed polycyclic group, and the substituted monovalent non-aromatic condensed heteropolycyclic group may be selected from:

deuterium, -F, -Cl, -Br, -I, a hydroxyl group, a cyano group, a nitro group, an amidino group, a hydrazino group, a hydrazono group, a C₁-C₆₀ (e.g. C₁-C₂₀) alkyl group, a C₂-C₆₀ (e.g. C₂-C₂₀) alkenyl group, a C₂-C₆₀ (e.g. C₂-C₂₀) alkynyl group, and a C₁-C₆₀ (e.g. C₁-C₂₀) alkoxy group;

a C₁-C₆₀ (e.g. C₁-C₂₀) alkyl group, a C₂-C₆₀ alkenyl group, a C₂-C₆₀ alkynyl group, and a C₁-C₆₀ (e.g. C₁-C₂₀) alkoxy group, each substituted with at least one selected from deuterium, -F, -Cl, -Br, -I, a hydroxyl group, a cyano group, a nitro group, an amidino group, a hydrazino group, a hydrazono group, a C₃-C₁₀ cycloalkyl group, a C₁-C₁₀ heterocycloalkyl group, a C₃-C₁₀ cycloalkenyl group, a C₁-C₁₀ heterocycloalkenyl group, a C₆-C₆₀ (e.g. C₆-C₃₀) aryl group, a C₆-C₆₀ (e.g. C₆-C₃₀) aryloxy group, a C₆-C₆₀ (e.g. C₆-C₃₀) arylthio group, a C₁-C₆₀ (e.g. C₁-C₂₀) heteroaryl group, a monovalent non-aromatic condensed polycyclic group, a monovalent non-aromatic condensed heteropolycyclic group, -Si(Q₁₁)(Q₁₂)(Q₁₃), -N(Q₁₁)(Q₁₂), -B(Q₁₁)(Q₁₂), -C(=O)(Q₁₁), -S(=O)₂(Q₁₁), and -P(=O)(Q₁₁)(Q₁₂); a C₃-C₁₀ cycloalkyl group, a C₁-C₁₀ heterocycloalkyl group, a C₃-C₁₀ cycloalkenyl group, a C₁-C₁₀ heterocycloalkenyl group, a C₆-C₆₀ (e.g. C₆-C₃₀) aryl group, a C₆-C₆₀ (e.g. C₆-C₃₀) aryloxy group, a C₆-C₆₀ (e.g. C₆-C₃₀) arylthio group, a C₁-C₆₀ (e.g. C₁-C₂₀) heteroaryl group, a monovalent non-aromatic condensed polycyclic group, and a monovalent non-aromatic condensed heteropolycyclic group;

a C₃-C₁₀ cycloalkyl group, a C₁-C₁₀ heterocycloalkyl group, a C₃-C₁₀ cycloalkenyl group, a C₁-C₁₀ heterocycloalkenyl group, a C₆-C₆₀ (e.g. C₆-C₃₀) aryl group, a C₆-C₆₀ (e.g. C₆-C₃₀) aryloxy group, a C₆-C₆₀ (e.g. C₆-C₃₀) arylthio group,

Synthesis of Compound 1

[0190] 3.54 g of Intermediate 1-1, 4.565 g of potassium tetrachloroplatinate (K_2PtCl_4), and 0.32 g of tetrabutylammonium bromide were dissolved in 200 mL of acetic acid (0.1 M) and stirred at a temperature of 120 °C for 72 hours. The reaction mixture was cooled to room temperature, and an organic layer was extracted therefrom three times by using dichloromethane and water. The extracted organic layer was dried by using $MgSO_4$ and concentrated, and column chromatography was used to obtain 2.2 g (yield: 40 %) of Compound 1. $C_{22}H_{12}N_2O_3Pt$: M+1 547.42.

Synthesis Example 2: Synthesis of Compound 5

[0191]

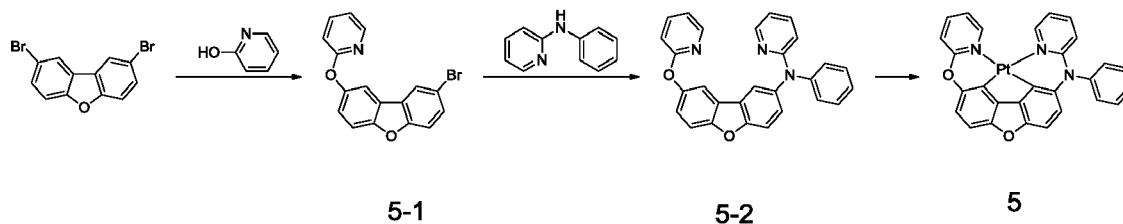
**Synthesis of Intermediate 5-1**

[0192] 1.7 g (yield: 50 %) of Intermediate 5-1 was obtained in substantially the same manner as in Synthesis of Intermediate 1-1, except that 0.95 g of pyridin-2-ol was used instead of 1.9 g of pyridin-2-ol.

Synthesis of Intermediate 5-2

[0193] 3.4 g of Intermediate 5-1, 1.7 g of N-phenylpyridin-2-amine, 0.45 g of tris(dibenzylideneacetone)dipalladium(0), 0.1 g of tri-tert-butylphosphine, and 2.9 g of sodium tert-butoxide were added to 200 mL of toluene and stirred at a temperature of 100 °C for 2 hours. After cooling, an organic layer obtained therefrom by washing the reaction mixture with ethyl acetate and water three times was dried by using $MgSO_4$ and dried under reduced pressure. Column chromatography was used to obtain 2.79 g (yield: 65 %) of Intermediate 5-2.

Synthesis of Compound 5

[0194] 3.1 g (yield: 50 %) of Compound 5 was obtained in substantially the same manner as in Synthesis of Compound 1, except that Intermediate 5-2 was used instead of Intermediate 1-1. The obtained compound was identified by LC-MS and 1H NMR. $C_{28}H_{17}N_3O_2Pt$: M+1 622.52.

Synthesis Example 3: Synthesis of Compound 31

[0195]

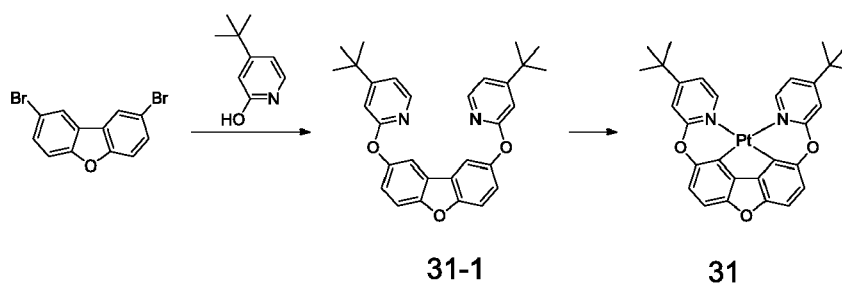
**Synthesis of Intermediate 31-1**

[0196] 2.1 g (yield: 45 %) of Intermediate 31-1 was obtained in substantially the same manner as in Synthesis of Intermediate 1-1, except that 4-(tert-butyl)pyridin-2-ol was used instead of pyridin-2-ol.

Synthesis of Compound 31

[0197] 2.31 g (yield: 35 %) of Compound 31 was obtained in substantially the same manner as in Synthesis of Compound 1, except that Intermediate 31-1 was used instead of Intermediate 1-1. The obtained compound was identified by LC-MS and ¹H NMR. C₃₀H₂₈N₂O₃Pt : M+1 659.62.

Synthesis Example 4: Synthesis of Compound 70

[0198]

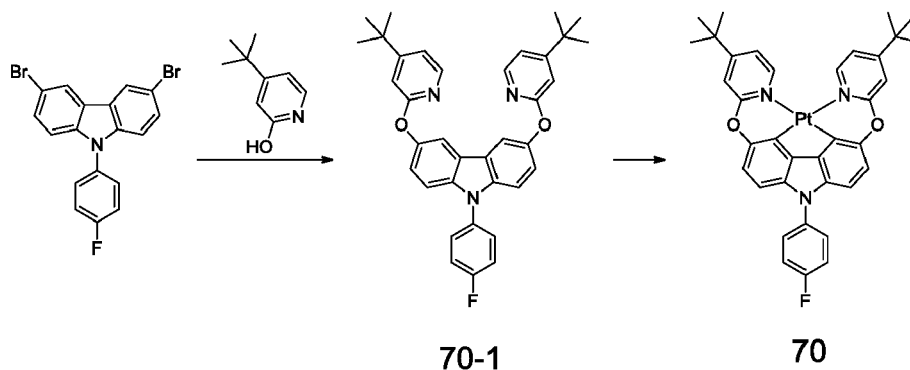
**Synthesis of Intermediate 70-1**

[0199] 3.26 g (yield: 60%) of Intermediate 70-1 was obtained in substantially the same manner as in Synthesis of Intermediate 31-1, except that 3,6-dibromo-9-(4-fluorophenyl)-9H-carbazole was used instead of 2,8-dibromodibenzofuran.

Synthesis of Compound 70

[0200] 3.16 g (yield: 42%) of Compound 70 was obtained in substantially the same manner as in Synthesis of Compound 1, except that Intermediate 70-1 was used instead of Intermediate 1-1. The obtained compound was identified by LC-MS and ¹H NMR. C₃₆H₃₂FN₃O₂Pt : M+1 752.72.

Synthesis Example 5: Synthesis of Compound 74

[0201]

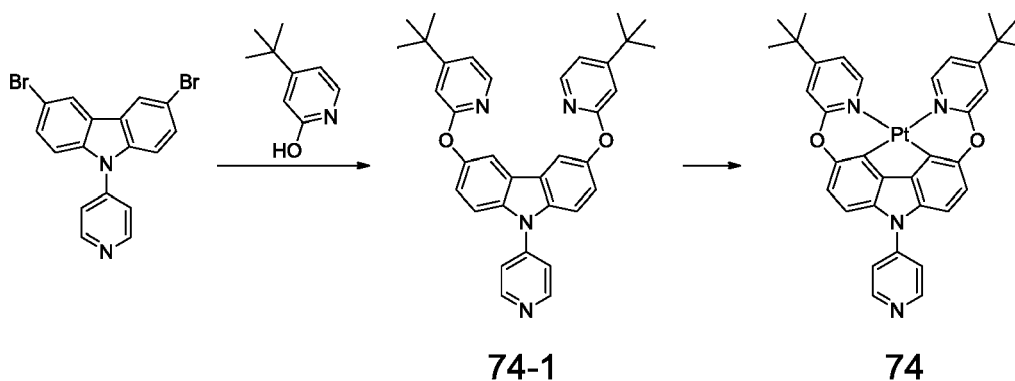
**Synthesis of Intermediate 74-1**

[0202] 2.98 g (yield: 55 %) of Intermediate 74-1 was obtained in substantially the same manner as in Synthesis of Intermediate 31-1, except that 3,6-dibromo-9-(pyridin-4-yl)-9H-carbazole was used instead of 2,8-dibromodibenzofuran.

Synthesis of Compound 74

[0203] 1.84 g (yield: 25 %) of Compound 74 was obtained in substantially the same manner as in Synthesis of Compound 1, except that Intermediate 74-1 was used instead of Intermediate 1-1. The obtained compound was identified by LC-MS and ¹H NMR. C₃₅H₃₂N₄O₂Pt : 735.72.

Synthesis Example 6: Synthesis of Compound 92

[0204]

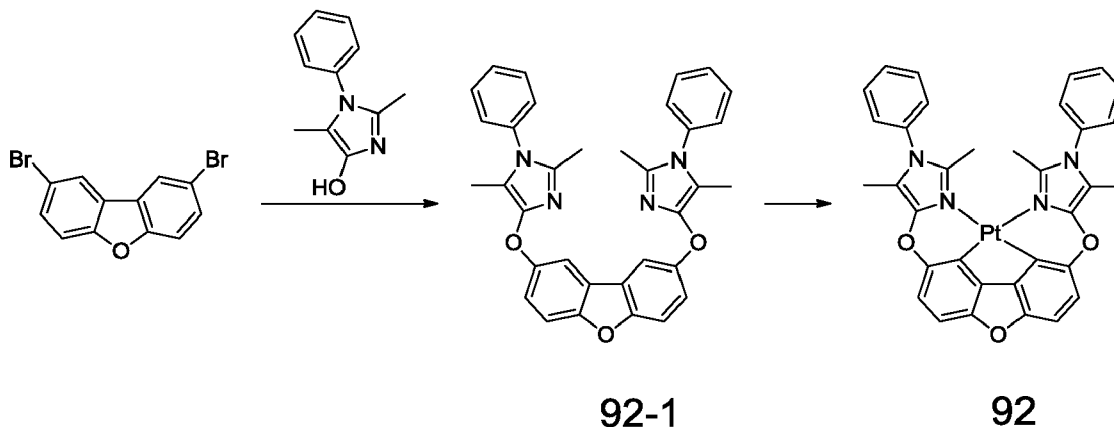
**Synthesis of Intermediate 92-1**

[0205] 2.97 g (yield: 55 %) of Intermediate 92-1 was obtained in substantially the same manner as in Synthesis of Intermediate 1-1, except that 2,5-dimethyl-1-phenyl-1H-imidazol-4-ol was used instead of pyridin-2-ol.

Synthesis of Compound 92

[0206] 1.47 g (yield: 20 %) of Compound 92 was obtained in substantially the same manner as in Synthesis of Compound 1, except that Intermediate 92-1 was used instead of Intermediate 1-1. The obtained compound was identified by LC-MS and ¹H NMR. C₃₄H₂₆N₄O₃Pt : M+1 733.66.

Synthesis Example 7: Synthesis of Compound 98

[0207]

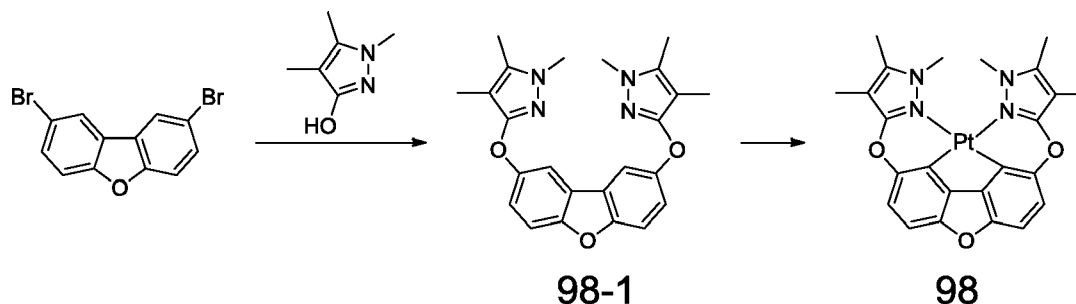
**Synthesis of Intermediate 98-1**

[0208] 1.87 g (yield: 45 %) of Intermediate 98-1 was obtained in substantially the same manner as in Synthesis of Intermediate 1-1, except that 1,4,5-trimethyl-1H-pyrazol-3-ol was used instead of pyridin-2-ol.

[0215] Synthesis methods of compounds other than Compounds synthesized according to Synthesis Examples 1 to 8 may also be easily recognized by those of ordinary skill in the art by referring to the synthesis mechanisms and source materials described above.

5 Example 1

[0216] As a substrate and an ITO anode, a Corning 15 Ω/cm^2 (1,200 Å) ITO glass substrate was cut to a size of 50 mm x 50 mm x 0.7 mm, sonicated with isopropyl alcohol and pure water each for 5 minutes, and then cleaned by exposure to ultraviolet rays and ozone for 30 minutes. Then, the ITO glass substrate was provided to a vacuum deposition apparatus.

10 [0217] 2-TNATA was vacuum-deposited on the ITO anode formed on the ITO glass substrate to form a hole injection layer having a thickness of 600 Å, and NPB was vacuum-deposited on the hole injection layer to form a hole transport layer having a thickness of 300 Å.

[0218] A mixed host of BCPDS and POPCPA at a weight ratio of 1:1 and a dopant Compound 1 were co-deposited on the hole transport layer at a ratio of 90:10 to form an emission layer having a thickness of 300 Å.

15 [0219] TSP01 was vacuum-deposited on the emission layer to form a hole blocking layer having a thickness of 50 Å. Then, Alq₃ was vacuum-deposited to form an electron transport layer having a thickness of 300 Å, LiF, which is an alkali metal halide, was vacuum-deposited to form an electron injection layer having a thickness of 10 Å, and Al was vacuum-deposited to form a LiF/Al cathode electrode having a thickness of 3,000 Å, thereby completing the manufacture of an organic light-emitting device.

20

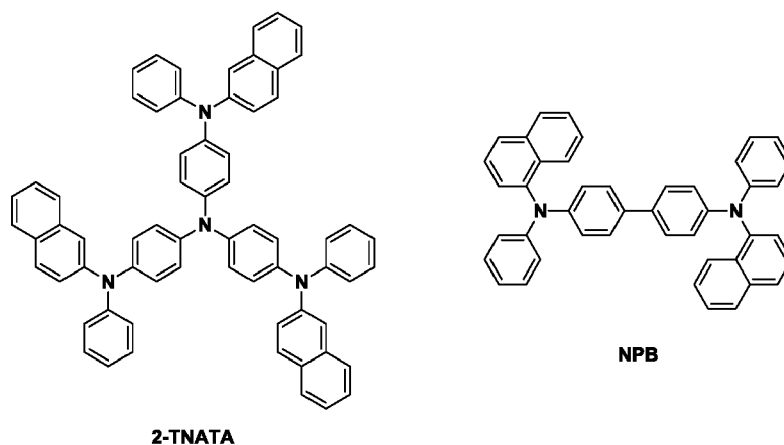

35

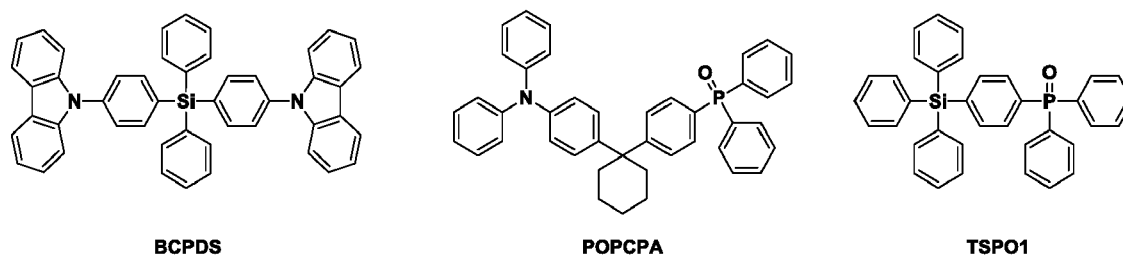

45

Examples 2 to 8 and Comparative Examples 1 and 2

50 [0220] Organic light-emitting devices were manufactured in the same manner as in Example 1, except that Compounds shown in Table 1 were each used instead of Compound 1 as a dopant in forming an emission layer.

Evaluation Example 1

55 [0221] The driving voltage, current density, luminance, external quantum efficiency (EQE), and maximum emission wavelength of the organic light-emitting devices manufactured according to Examples 1 to 8 and Comparative Examples 1 and 2 were measured by using Keithley SMU 236 and a luminance meter PR650, and results thereof are shown in Table 1.

Table 1

	Emission layer	Driving voltage (V)	Current density (mA/cm ²)	Luminance (cd/m ²)	Efficiency (cd/A)	Emission color	Emission wavelength (nm)
Example 1	1	5.22	50	4225	8.45	Blue	467
Example 2	5	5.35	50	4402	8.804	Blue	468
Example 3	31	5.13	50	4133	8.266	Blue	463
Example 4	70	5.16	50	4020	8.04	Blue	468
Example 5	74	5.42	50	4051	8.102	Blue	460
Example 6	92	5.39	50	4122	8.244	Blue	464
Example 7	98	5.58	50	4072	8.144	Blue	462
Example 8	106	5.23	50	4067	8.134	Blue	458
Comparative Example 1	Flrpic	6.56	50	3870	7.74	Blue	478
Comparative Example 2	D-2	6.27	50	3958	7.916	Blue	471

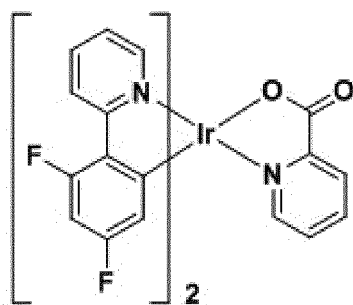

Flrpic

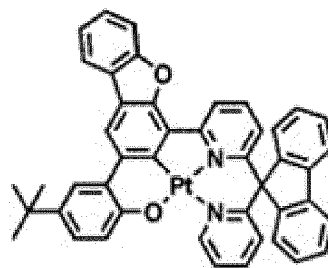

D-2

[0222] Referring to Table 1, it is confirmed that the organic light-emitting devices of Examples 1 to 8 have a low driving voltage, and high efficiency, as compared with those of the organic light-emitting devices of Comparative Examples 1 to 2.

[0223] The organic light-emitting device may have a low driving voltage, high efficiency, and a long lifespan.

[0224] It should be understood that embodiments described herein should be considered in a descriptive sense only and not for purposes of limitation. Descriptions of features or aspects within each embodiment should typically be considered as available for other similar features or aspects in other embodiments.

[0225] It will be understood that, although the terms "first," "second," "third," etc., may be used herein to describe various elements, components, regions, layers and/or sections, these elements, components, regions, layers and/or sections should not be limited by these terms. These terms are used to distinguish one element, component, region, layer or section from another element, component, region, layer or section. Thus, a first element, component, region, layer or section described below could be termed a second element, component, region, layer or section, without departing from the spirit and scope of the present disclosure.

[0226] Spatially relative terms, such as "beneath," "below," "lower," "under," "above," "upper," and the like, may be used herein for ease of explanation to describe one element or feature's relationship to another element(s) or feature(s) as illustrated in the figures. It will be understood that the spatially relative terms are intended to encompass different orientations of the device in use or in operation, in addition to the orientation depicted in the figures. For example, if the device in the figures is turned over, elements described as "below" or "beneath" or "under" other elements or features would then be oriented "above" the other elements or features. Thus, the example terms "below" and "under" can encompass both an orientation of above and below. The device may be otherwise oriented (e.g., rotated 90 degrees or at other orientations) and the spatially relative descriptors used herein should be interpreted accordingly.

[0227] It will be understood that when an element or layer is referred to as being "on," "connected to," or "coupled to" another element or layer, it can be directly on, connected to, or coupled to the other element or layer, or one or more intervening elements or layers may be present. In addition, it will also be understood that when an element or layer is referred to as being "between" two elements or layers, it can be the only element or layer between the two elements or layers, or one or more intervening elements or layers may also be present.

[0228] The terminology used herein is for the purpose of describing particular embodiments only and is not intended to be limiting of the present disclosure. As used herein, the singular forms "a" and "an" are intended to include the plural forms as well, unless the context clearly indicates otherwise. It will be further understood that the terms "comprises," "comprising," "includes," and "including," when used in this specification, specify the presence of the stated features, integers, acts, operations, elements, and/or components, but do not preclude the presence or addition of one or more other features, integers, acts, operations, elements, components, and/or groups thereof.

[0229] As used herein, the terms "substantially," "about," and similar terms are used as terms of approximation and not as terms of degree, and are intended to account for the inherent deviations in measured or calculated values that would be recognized by those of ordinary skill in the art. Further, the use of "may" when describing embodiments of the present disclosure refers to "one or more embodiments of the present disclosure." As used herein, the terms "use," "using," and "used" may be considered synonymous with the terms "utilize," "utilizing," and "utilized," respectively.

[0230] Also, any numerical range recited herein is intended to include all subranges of the same numerical precision subsumed within the recited range. For example, a range of "1.0 to 10.0" is intended to include all subranges between (and including) the recited minimum value of 1.0 and the recited maximum value of 10.0, that is, having a minimum value equal to or greater than 1.0 and a maximum value equal to or less than 10.0, such as, for example, 2.4 to 7.6. Any maximum numerical limitation recited herein is intended to include all lower numerical limitations subsumed therein, and any minimum numerical limitation recited in this specification is intended to include all higher numerical limitations subsumed therein.

[0231] While one or more embodiments have been described with reference to the figures, it will be understood by those of ordinary skill in the art that various changes in form and details may be made therein without departing from the scope as defined by the following claims, and equivalents thereof.

Claims

1. An organic light-emitting device comprising:

a first electrode;

a second electrode facing the first electrode; and

an organic layer between the first electrode and the second electrode and comprising an emission layer, wherein the organic layer comprises at least one of the organometallic compound represented by Formula 1:

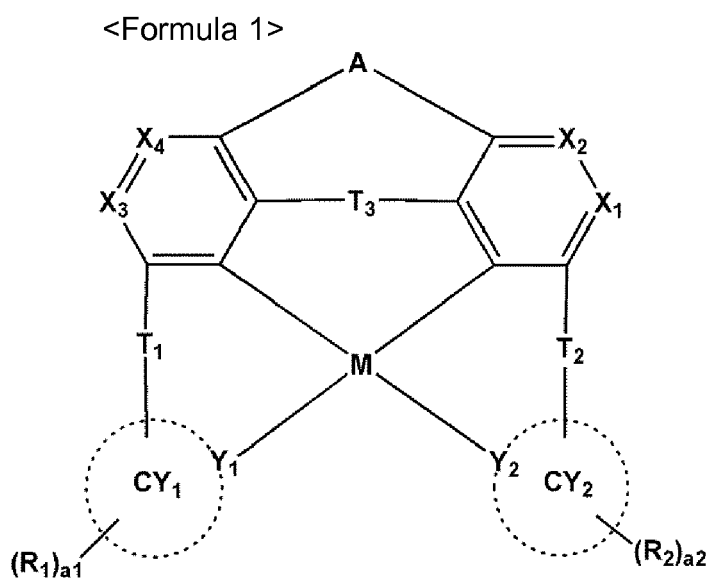

wherein, in Formula 1,

EP 3 544 075 A1

M is selected from transition metals,

CY₁ and CY₂ are each independently a C₅-C₆₀ carbocyclic group or a C₁-C₆₀ heterocyclic group,

X₁ is C(R₁₁) or N, X₂ is C(R₁₂) or N, X₃ is C(R₁₃) or N, and X₄ is C(R₁₄) or N,

Y₁ and Y₂ are each independently C or N,

a bond between Y₁ and M and a bond between Y₂ and M are each a coordinate bond,

A is selected from O, S, N(R₃), C(R₃)(R₄), and Si(R₃)(R₄),

T₁ to T₃ are each independently selected from a single bond, *-O-*, *-S-*, *-C(R₅)(R₆)-*, *-C(R₅)=*, *=C(R₅)-*, *-C(R₅)=C(R₆)-*, *-C(=O)-*, *-C(=S)-*, *-C≡C-*, *-B(R₅)-*, *-N(R₅)-*, *-P(R₅)-*, *-Si(R₅)(R₆)-*, and *-Ge(R₅)(R₆)-*,

R₁ to R₆ and R₁₁ to R₁₄ are each independently selected from hydrogen, deuterium, -F, -Cl, -Br, -I, a hydroxyl group, a cyano group, a nitro group, an amidino group, a hydrazino group, a hydrazono group, a substituted or unsubstituted C₁-C₆₀ alkyl group, a substituted or unsubstituted C₂-C₆₀ alkenyl group, a substituted or unsubstituted C₂-C₆₀ alkynyl group, a substituted or unsubstituted C₁-C₆₀ alkoxy group, a substituted or unsubstituted C₃-C₁₀ cycloalkyl group, a substituted or unsubstituted C₁-C₁₀ heterocycloalkyl group, a substituted or unsubstituted C₃-C₁₀ cycloalkenyl group, a substituted or unsubstituted C₁-C₁₀ heterocycloalkenyl group, a substituted or unsubstituted C₆-C₆₀ aryl group, a substituted or unsubstituted C₆-C₆₀ aryloxy group, a substituted or unsubstituted C₆-C₆₀ arylthio group, a substituted or unsubstituted C₁-C₆₀ heteroaryl group, a substituted or unsubstituted monovalent non-aromatic condensed polycyclic group, a substituted or unsubstituted monovalent non-aromatic condensed heteropolycyclic group, -Si(Q₁)(Q₂)(Q₃), -N(Q₁)(Q₂), -B(Q₁)(Q₂), -P(Q₁)(Q₂), -C(=O)(Q₁), -S(=O)₂(Q₁), and -P(=O)(Q₁)(Q₂), where-
in two neighboring groups selected from R₁ to R₆ are optionally linked to form a substituted or unsubstituted C₅-C₆₀ carbocyclic group or a substituted or unsubstituted C₁-C₆₀ heterocyclic group,

a₁ and a₂ are each independently an integer of 1 to 5, wherein, when a₁ is two or more, two or more R₁(s) are identical to or different from each other, and when a₂ is two or more, two or more R₂(s) are identical to or different from each other,

at least one substituent of the substituted C₅-C₆₀ carbocyclic group, the substituted C₁-C₆₀ heterocyclic group, the substituted C₁-C₆₀ alkyl group, the substituted C₂-C₆₀ alkenyl group, the substituted C₂-C₆₀ alkynyl group, the substituted C₁-C₆₀ alkoxy group, the substituted C₃-C₁₀ cycloalkyl group, the substituted C₁-C₁₀ heterocycloalkyl group, the substituted C₃-C₁₀ cycloalkenyl group, the substituted C₁-C₁₀ heterocycloalkenyl group, the substituted C₆-C₆₀ aryl group, the substituted C₆-C₆₀ aryloxy group, the substituted C₆-C₆₀ arylthio group, the substituted C₁-C₆₀ heteroaryl group, the substituted monovalent non-aromatic condensed polycyclic group, and the substituted monovalent non-aromatic condensed heteropolycyclic group is selected from:

deuterium (-D), -F, -Cl, -Br, -I, a hydroxyl group, a cyano group, a nitro group, an amidino group, a hydrazino group, a hydrazono group, a C₁-C₆₀ alkyl group, a C₂-C₆₀ alkenyl group, a C₂-C₆₀ alkynyl group, and a C₁-C₆₀ alkoxy group;

a C₁-C₆₀ alkyl group, a C₂-C₆₀ alkenyl group, a C₂-C₆₀ alkynyl group, and a C₁-C₆₀ alkoxy group, each substituted with at least one selected from deuterium, -F, -Cl, -Br, -I, a hydroxyl group, a cyano group, a nitro group, an amidino group, a hydrazino group, a hydrazono group, a C₃-C₁₀ cycloalkyl group, a C₁-C₁₀ heterocycloalkyl group, a C₃-C₁₀ cycloalkenyl group, a C₁-C₁₀ heterocycloalkenyl group, a C₆-C₆₀ aryl group, a C₆-C₆₀ aryloxy group, a C₆-C₆₀ arylthio group, a C₁-C₆₀ heteroaryl group, a monovalent non-aromatic condensed polycyclic group, a monovalent non-aromatic condensed heteropolycyclic group, -Si(Q₁₁)(Q₁₂)(Q₁₃), -N(Q₁₁)(Q₁₂), -B(Q₁₁)(Q₁₂), -C(=O)(Q₁₁), -S(=O)₂(Q₁₁), and -P(=O)(Q₁₁)(Q₁₂);

a C₃-C₁₀ cycloalkyl group, a C₁-C₁₀ heterocycloalkyl group, a C₃-C₁₀ cycloalkenyl group, a C₁-C₁₀ heterocycloalkenyl group, a C₆-C₆₀ aryl group, a C₆-C₆₀ aryloxy group, a C₆-C₆₀ arylthio group, a C₁-C₆₀ heteroaryl group, a monovalent non-aromatic condensed polycyclic group, and a monovalent non-aromatic condensed heteropolycyclic group;

a C₃-C₁₀ cycloalkyl group, a C₁-C₁₀ heterocycloalkyl group, a C₃-C₁₀ cycloalkenyl group, a C₁-C₁₀ heterocycloalkenyl group, a C₆-C₆₀ aryl group, a C₆-C₆₀ aryloxy group, a C₆-C₆₀ arylthio group, a C₁-C₆₀ heteroaryl group, a monovalent non-aromatic condensed polycyclic group, and a monovalent non-aromatic condensed heteropolycyclic group, each substituted with at least one selected from deuterium, -F, -Cl, -Br, -I, a hydroxyl group, a cyano group, a nitro group, an amidino group, a hydrazino group, a hydrazono group, a C₁-C₆₀ alkyl group, a C₂-C₆₀ alkenyl group, a C₂-C₆₀ alkynyl group, a C₁-C₆₀ alkoxy group, a C₃-C₁₀ cycloalkyl group, a C₁-C₁₀ heterocycloalkyl group, a C₃-C₁₀ cycloalkenyl group, a C₁-C₁₀ heterocycloalkenyl group, a C₆-C₆₀ aryl group, a C₆-C₆₀ aryloxy group, a C₆-C₆₀ arylthio group, a C₁-C₆₀ heteroaryl group, a monovalent non-aromatic condensed polycyclic group, a monovalent non-aromatic condensed heteropolycyclic group, -Si(Q₂₁)(Q₂₂)(Q₂₃), -N(Q₂₁)(Q₂₂), -B(Q₂₁)(Q₂₂), -C(=O)(Q₂₁), -S(=O)₂(Q₂₁), and -P(=O)(Q₂₁)(Q₂₂); and -Si(Q₃₁)(Q₃₂)(Q₃₃), -N(Q₃₁)(Q₃₂), -B(Q₃₁)(Q₃₂), -C(=O)(Q₃₁), -S(=O)₂(Q₃₁), and-

P(=O)(Q₃₁)(Q₃₂),

Q₁ to Q₃, Q₁₁ to Q₁₃, Q₂₁ to Q₂₃, and Q₃₁ to Q₃₃ are each independently selected from hydrogen, deuterium, -F, -Cl, -Br, -I, a hydroxyl group, a cyano group, a nitro group, an amidino group, a hydrazino group, a hydrazono group, a C₁-C₆₀ alkyl group, a C₂-C₆₀ alkenyl group, a C₂-C₆₀ alkynyl group, a C₁-C₆₀ alkoxy group, a C₃-C₁₀ cycloalkyl group, a C₁-C₁₀ heterocycloalkyl group, a C₃-C₁₀ cycloalkenyl group, a C₁-C₁₀ heterocycloalkenyl group, a C₆-C₆₀ aryl group, a C₁-C₆₀ heteroaryl group, a monovalent non-aromatic condensed polycyclic group, a monovalent non-aromatic condensed heteropolycyclic group, a biphenyl group, and a terphenyl group, and

* and *' each indicate a binding site to a neighboring atom.

2. An organic light-emitting device according to claim 1, wherein:

the first electrode is an anode,

the second electrode is a cathode,

the organic layer comprises: i) a hole transport region between the first electrode and the emission layer and comprising a hole injection layer, a hole transport layer, a buffer layer, an electron blocking layer, or any combination thereof, and ii) an electron transport region between the emission layer and the second electrode and comprising a hole blocking layer, an electron transport layer, an electron injection layer, or any combination thereof.

3. An organic light-emitting device according to claim 1 or claim 2, wherein:

the emission layer comprises the organometallic compound,

the organometallic compound in the emission layer serves as a phosphorescent dopant such that phosphorescence is emitted from the emission layer; or

the organometallic compound in the emission layer serves as a delayed fluorescent dopant such that delayed fluorescence is emitted from the emission layer.

4. An organic light-emitting device according to any one of claims 1 to 3, wherein:

the emission layer consists of the organometallic compound; or

the emission layer further comprises a host, and an amount of the organometallic compound in the emission layer is in a range of about 0.01 parts by weight to about 50 parts by weight based on 100 parts by weight of the emission layer.

5. An organic light-emitting device according to any one of claims 1 to 4, wherein:

the emission layer comprises at least one of a pyrene-containing compound, an arylamine-based compound, and a styryl-based compound.

6. An electronic apparatus comprising:

a thin film transistor; and

the organic light-emitting device according to any one of claims 1 to 5,

wherein the thin film transistor comprises a source electrode, a drain electrode, an active layer, and a gate electrode, and

the first electrode of the organic light-emitting device is electrically coupled to one of the source electrode and the drain electrode of the thin film transistor.

7. An organometallic compound represented by Formula 1:

Formula 1

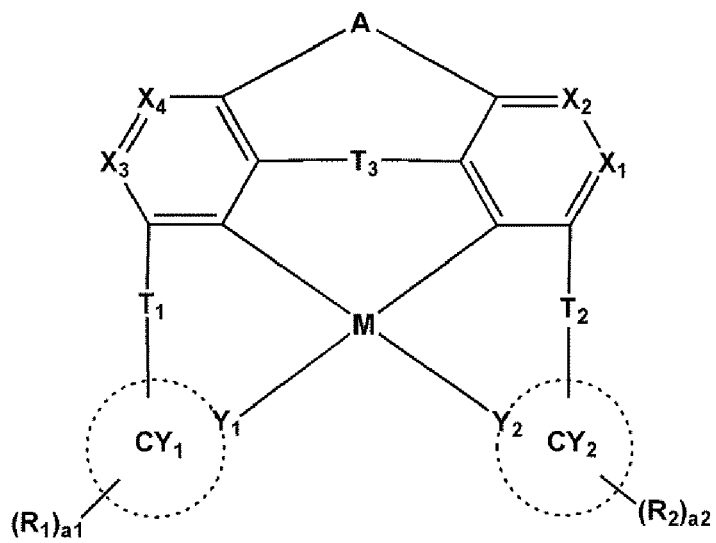

wherein, in Formula 1,

M is selected from transition metals,

CY₁ and CY₂ are each independently a C₅-C₆₀ carbocyclic group or a C₁-C₆₀ heterocyclic group,

X₁ is C(R₁₁) or N, X₂ is C(R₁₂) or N, X₃ is C(R₁₃) or N, and X₄ is C(R₁₄) or N,

Y₁ and Y₂ are each independently C or N,

a bond between Y₁ and M and a bond between Y₂ and M are each a coordinate bond,

A is selected from O, S, N(R₃), C(R₃)(R₄), and Si(R₃)(R₄),

T₁ to T₃ are each independently selected from a single bond, *-O-*, *-S-*, *-C(R₅)(R₆)-*, *-C(R₅)=*, *=C(R₅)-*, *-C(R₅)=C(R₆)-*, *-C(=O)-*, *-C(=S)-*, *-C≡C-*, *-B(R₅)-*, *-N(R₅)-*, *-P(R₅)-*, *-Si(R₅)(R₆)-*, and *-Ge(R₅)(R₆)-*,

R₁ to R₆ and R₁₁ to R₁₄ are each independently selected from hydrogen, deuterium, -F, -Cl, -Br, -I, a hydroxyl group, a cyano group, a nitro group, an amidino group, a hydrazino group, a hydrazono group, a substituted or unsubstituted C₁-C₆₀ alkyl group, a substituted or unsubstituted C₂-C₆₀ alkenyl group, a substituted or unsubstituted C₂-C₆₀ alkynyl group, a substituted or unsubstituted C₁-C₆₀ alkoxy group, a substituted or unsubstituted C₃-C₁₀ cycloalkyl group, a substituted or unsubstituted C₁-C₁₀ heterocycloalkyl group, a substituted or unsubstituted C₃-C₁₀ cycloalkenyl group, a substituted or unsubstituted C₁-C₁₀ heterocycloalkenyl group, a substituted or unsubstituted C₆-C₆₀ aryl group, a substituted or unsubstituted C₆-C₆₀ aryloxy group, a substituted or unsubstituted C₆-C₆₀ arylthio group, a substituted or unsubstituted C₁-C₆₀ heteroaryl group, a substituted or unsubstituted monovalent non-aromatic condensed polycyclic group, a substituted or unsubstituted monovalent non-aromatic condensed heteropolycyclic group, -Si(Q₁)(Q₂)(Q₃), -N(Q₁)(Q₂), -B(Q₁)(Q₂), -P(Q₁)(Q₂), -C(=O)(Q₁), -S(=O)₂(Q₁), and -P(=O)(Q₁)(Q₂), wherein two neighboring groups selected from R₁ to R₆ are optionally linked to form a substituted or unsubstituted C₅-C₆₀ carbocyclic group or a substituted or unsubstituted C₁-C₆₀ heterocyclic group,

a₁ and a₂ are each independently an integer of 1 to 5, wherein, when a₁ is two or more, two or more R₁(s) are identical to or different from each other, and when a₂ is two or more, two or more R₂(s) are identical to or different from each other,

at least one substituent of the substituted C₅-C₆₀ carbocyclic group, the substituted C₁-C₆₀ heterocyclic group, the substituted C₁-C₆₀ alkyl group, the substituted C₂-C₆₀ alkenyl group, the substituted C₂-C₆₀ alkynyl group, the substituted C₁-C₆₀ alkoxy group, the substituted C₃-C₁₀ cycloalkyl group, the substituted C₁-C₁₀ heterocycloalkyl group, the substituted C₃-C₁₀ cycloalkenyl group, the substituted C₁-C₁₀ heterocycloalkenyl group, the substituted C₆-C₆₀ aryl group, the substituted C₆-C₆₀ aryloxy group, the substituted C₆-C₆₀ arylthio group, the substituted C₁-C₆₀ heteroaryl group, the substituted monovalent non-aromatic condensed polycyclic group, and the substituted monovalent non-aromatic condensed heteropolycyclic group is selected from:

deuterium (-D), -F, -Cl, -Br, -I, a hydroxyl group, a cyano group, a nitro group, an amidino group, a hydrazino group, a hydrazono group, a C₁-C₆₀ alkyl group, a C₂-C₆₀ alkenyl group, a C₂-C₆₀ alkynyl group, and a C₁-C₆₀ alkoxy group;

a C₁-C₆₀ alkyl group, a C₂-C₆₀ alkenyl group, a C₂-C₆₀ alkynyl group, and a C₁-C₆₀ alkoxy group, each substituted with at least one selected from deuterium, -F, -Cl, -Br, -I, a hydroxyl group, a cyano group, a nitro group, an amidino group, a hydrazino group, a hydrazono group, a C₃-C₁₀ cycloalkyl group, a C₁-C₁₀ heterocycloalkyl group, a C₃-C₁₀ cycloalkenyl group, a C₁-C₁₀ heterocycloalkenyl group, a C₆-C₆₀ aryl group, a C₆-C₆₀ aryloxy group, a C₆-C₆₀ arylthio group, a C₁-C₆₀ heteroaryl group, a monovalent non-aromatic condensed polycyclic group, a monovalent non-aromatic condensed heteropolycyclic group, -Si(Q₁₁)(Q₁₂)(Q₁₃), -N(Q₁₁)(Q₁₂), -B(Q₁₁)(Q₁₂), -C(=O)(Q₁₁), -S(=O)₂(Q₁₁), and -P(=O)(Q₁₁)(Q₁₂);

a C₃-C₁₀ cycloalkyl group, a C₁-C₁₀ heterocycloalkyl group, a C₃-C₁₀ cycloalkenyl group, a C₁-C₁₀ heterocycloalkenyl group, a C₆-C₆₀ aryl group, a C₆-C₆₀ aryloxy group, a C₆-C₆₀ arylthio group, a C₁-C₆₀ heteroaryl group, a monovalent non-aromatic condensed polycyclic group, and a monovalent non-aromatic condensed heteropolycyclic group;

a C₃-C₁₀ cycloalkyl group, a C₁-C₁₀ heterocycloalkyl group, a C₃-C₁₀ cycloalkenyl group, a C₁-C₁₀ heterocycloalkenyl group, a C₆-C₆₀ aryl group, a C₆-C₆₀ aryloxy group, a C₆-C₆₀ arylthio group, a C₁-C₆₀ heteroaryl group, a monovalent non-aromatic condensed polycyclic group, and a monovalent non-aromatic condensed heteropolycyclic group, each substituted with at least one selected from deuterium, -F, -Cl, -Br, -I, a hydroxyl group, a cyano group, a nitro group, an amidino group, a hydrazino group, a hydrazono group,

a C₁-C₆₀ alkyl group, a C₂-C₆₀ alkenyl group, a C₂-C₆₀ alkynyl group, a C₁-C₆₀ alkoxy group, a C₃-C₁₀ cycloalkyl group, a C₁-C₁₀ heterocycloalkyl group, a C₃-C₁₀ cycloalkenyl group, a C₁-C₁₀ heterocycloalkenyl group, a C₆-C₆₀ aryl group, a C₆-C₆₀ aryloxy group, a C₆-C₆₀ arylthio group, a C₁-C₆₀ heteroaryl group, a monovalent non-aromatic condensed polycyclic group, a monovalent non-aromatic condensed heteropolycyclic group, -Si(Q₂₁)(Q₂₂)(Q₂₃), -N(Q₂₁)(Q₂₂), -B(Q₂₁)(Q₂₂), -C(=O)(Q₂₁), -S(=O)₂(Q₂₁), and -P(=O)(Q₂₁)(Q₂₂); and

-Si(Q₃₁)(Q₃₂)(Q₃₃), -N(Q₃₁)(Q₃₂), -B(Q₃₁)(Q₃₂), -C(=O)(Q₃₁), -S(=O)₂(Q₃₁), and -P(=O)(Q₃₁)(Q₃₂),

Q₁ to Q₃, Q₁₁ to Q₁₃, Q₂₁ to Q₂₃, and Q₃₁ to Q₃₃ are each independently selected from hydrogen, deuterium, -F, -Cl, -Br, -I, a hydroxyl group, a cyano group, a nitro group, an amidino group, a hydrazino group, a hydrazono group, a C₁-C₆₀ alkyl group, a C₂-C₆₀ alkenyl group, a C₂-C₆₀ alkynyl group, a C₁-C₆₀ alkoxy group, a C₃-C₁₀ cycloalkyl group, a C₁-C₁₀ heterocycloalkyl group, a C₃-C₁₀ cycloalkenyl group, a C₁-C₁₀ heterocycloalkenyl group, a C₆-C₆₀ aryl group, a C₁-C₆₀ heteroaryl group, a monovalent non-aromatic condensed polycyclic group, a monovalent non-aromatic condensed heteropolycyclic group, a biphenyl group, and a terphenyl group, and

* and *' each indicate a binding site to a neighboring atom.

8. An organometallic compound according to claim 7, wherein:

M is selected from platinum (Pt), palladium (Pd), copper (Cu), silver (Ag), gold (Au), rhodium (Rh), iridium (Ir), ruthenium (Ru), and osmium (Os).

9. An organometallic compound according to claim 7 or claim 8, wherein:

CY₁ and CY₂ are each independently selected from:

a 5-membered carbocyclic group, a 6-membered carbocyclic group, a 5-membered heterocyclic group, and a 6-membered heterocyclic group; and

a condensed ring in which two or more groups selected from a 5-membered carbocyclic group, a 6-membered carbocyclic group, a 5-membered heterocyclic group, and a 6-membered heterocyclic group are condensed.

10. An organometallic compound according to any one of claims 7 to 9, wherein: a moiety represented by

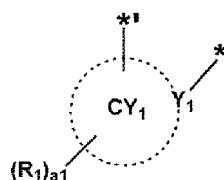

in Formula 1 is selected from groups represented by Formulae 3-1 to 3-40:

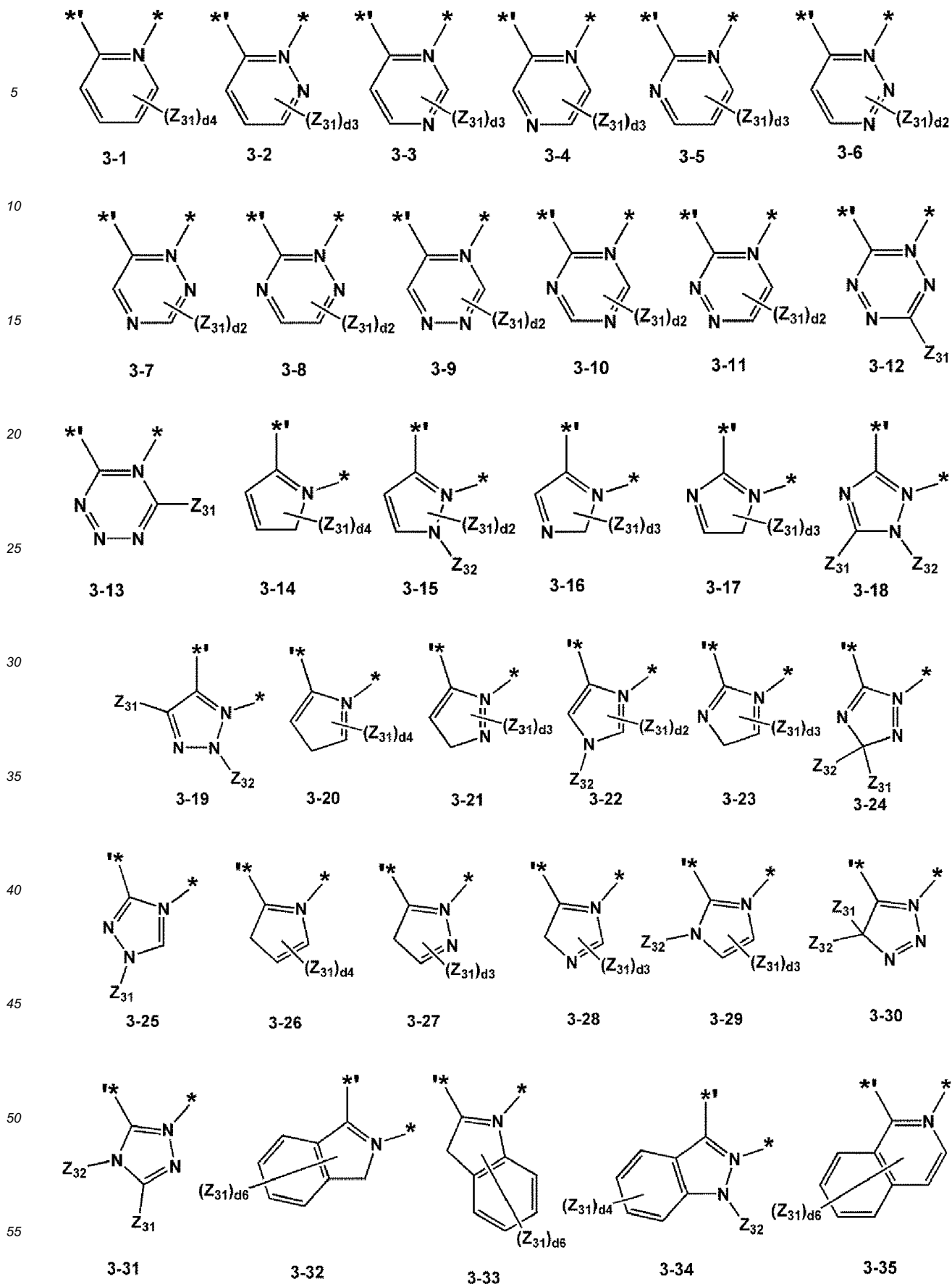

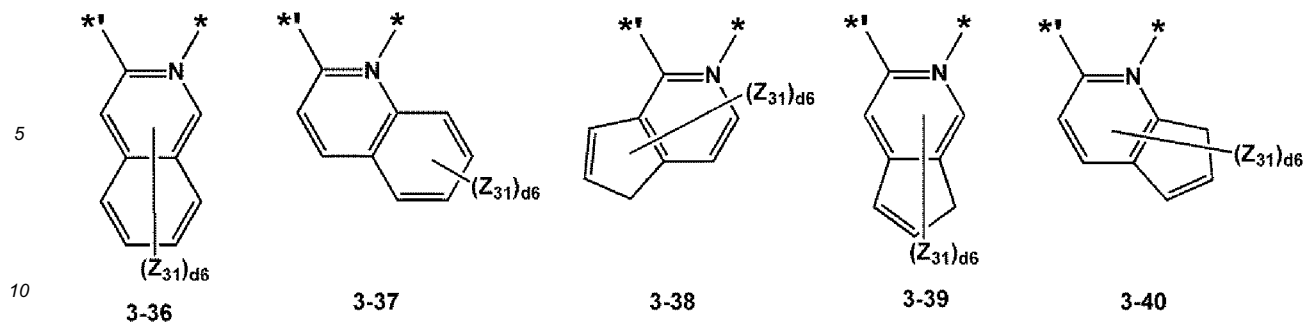

15 wherein Z_{31} to Z_{32} are each independently selected from hydrogen, deuterium, -F, -Cl, -Br, -I, a hydroxyl group, a cyano group, a nitro group, an amidino group, a hydrazino group, a hydrazono group, a C_1 - C_{20} alkyl group, a C_2 - C_{20} alkenyl group, a C_2 - C_{20} alkynyl group, a C_1 - C_{20} alkoxy group, a cyclopentyl group, a cyclohexyl group, a phenyl group, a naphthyl group, a pyridinyl group, a pyrimidinyl group, a pyrazinyl group, a pyridazinyl group, an indolyl group, an isoindolyl group, an indazolyl group, a quinolinyl group, an isoquinolinyl group, a quinoxalinyl group, a quinazoliny group, a cinnolinyl group, and a triazinyl group,

20 d_2 is an integer of 0 to 2,

d_3 is an integer of 0 to 3,

d_4 is an integer of 0 to 4,

d_6 is an integer of 0 to 6, and

* indicates a binding site to M in Formula 1, and ** indicates a binding site to a neighboring group.

25 11. An organometallic compound according to any one of claims 7 to 10, wherein: a moiety represented by

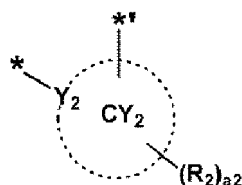

35 in Formula 1 is selected from groups represented by Formulae 4-1 to 4-40:

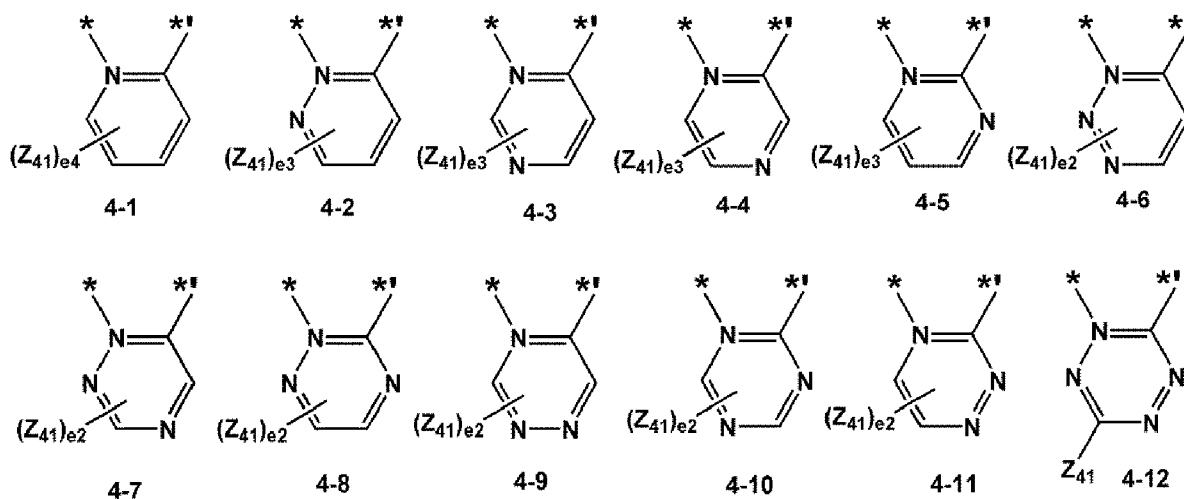

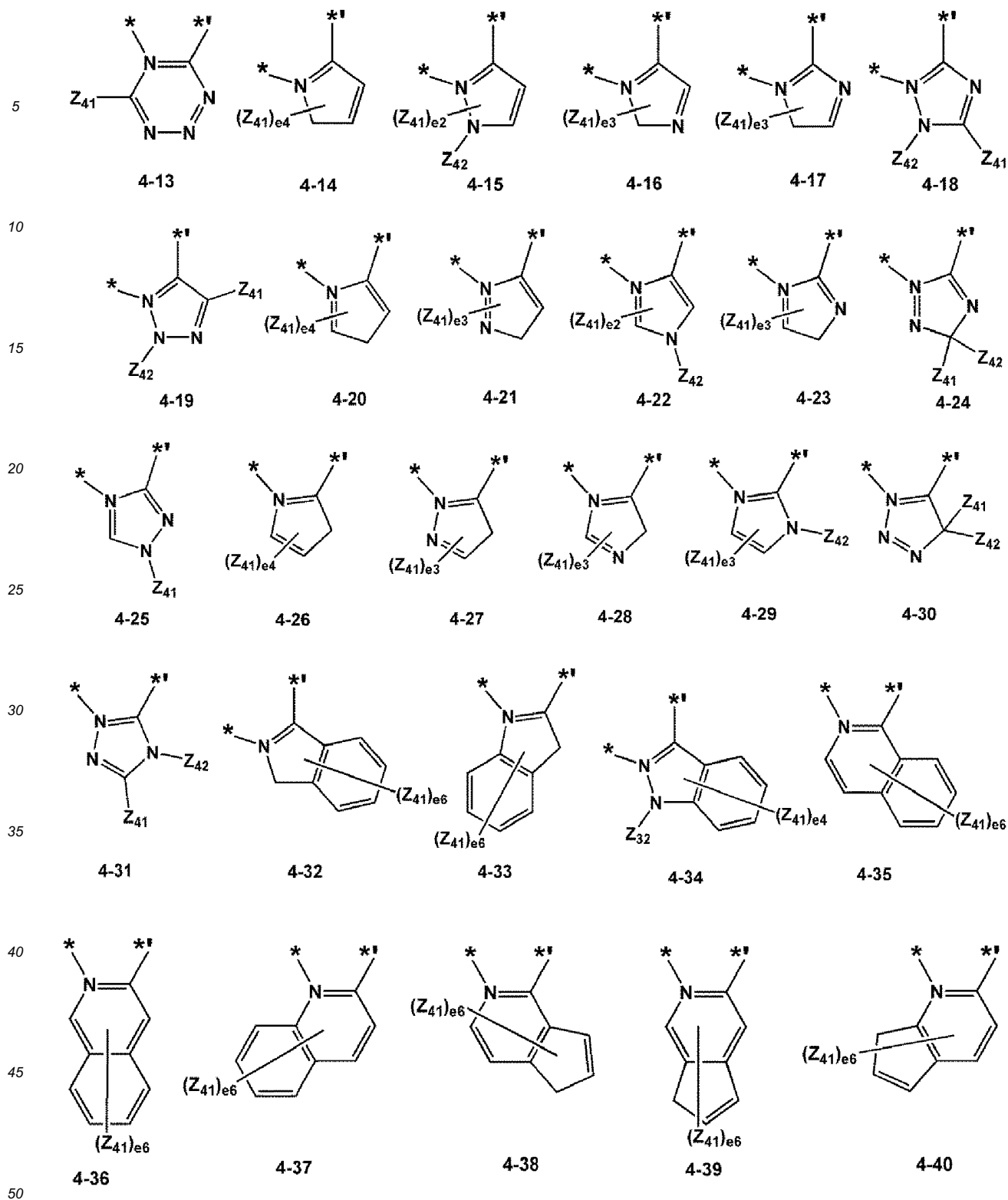

wherein Z_{41} to Z_{42} are each independently selected from hydrogen, deuterium, -F, -Cl, -Br, -I, a hydroxyl group, a cyano group, a nitro group, an amidino group, a hydrazino group, a hydrazono group, a C_1 - C_{20} alkyl group, a C_2 - C_{20} alkenyl group, a C_2 - C_{20} alkynyl group, a C_1 - C_{20} alkoxy group, a cyclopentyl group, a cyclohexyl group, a phenyl group, a naphthyl group, a pyridinyl group, a pyrimidinyl group, a pyrazinyl group, a pyridazinyl group, an indolyl group, an isoindolyl group, an indazolyl group, a quinolinyl group, an isoquinolinyl group, a quinoxalinyl group, a quinazolinyl group, a cinnolinyl group, and a triazinyl group, e_2 is an integer of 0 to 2,

55

e3 is an integer of 0 to 3,
 e4 is an integer of 0 to 4,
 e6 is an integer of 0 to 6, and,

* indicates a binding site to M in Formula 1, and ** indicates a binding site to a neighboring group.

5

12. An organometallic compound according to any one of claims 7 to 11, wherein:

X_1 is C(R₁₁), X_2 is C(R₁₂), X_3 is C(R₁₃), and X_4 is C(R₁₄),

10 R₁₁ to R₁₄ are each independently selected from hydrogen, deuterium, -F, -Cl, -Br, -I, a hydroxyl group, a cyano group, a nitro group, an amidino group, a hydrazino group, a hydrazono group, a C₁-C₂₀ alkyl group, and a C₁-C₂₀ alkoxy group.

13. An organometallic compound according to any one of claims 7 to 12, wherein:

Y₁ and Y₂ are each N.

15

14. An organometallic compound according to any one of claims 7 to 13, wherein:

T₃ is a single bond, and

20 T₁ and T₂ are each independently selected from *-O-*, *-S-*, *-C(R₇)(R₈)-*, *-B(R₇)-*, *-N(R₇)-*, *-P(R₇)-*, *-Si(R₇)(R₈)-*, and *-P(R₇)(R₈)-*.

15. An organometallic compound according to claim 14, wherein:

T₁ and T₂ are identical to each other.

25

16. An organometallic compound according to any one of claims 7 to 15, wherein:

R₁ to R₆ and R₁₁ to R₁₄ are each independently selected from:

hydrogen, deuterium, -F, -Cl, -Br, -I, a hydroxyl group, a cyano group, a nitro group, an amidino group, a hydrazino group, a hydrazono group, a C₁-C₂₀ alkyl group, and a C₁-C₂₀ alkoxy group;

30 a C₁-C₂₀ alkyl group and a C₁-C₂₀ alkoxy group, each substituted with at least one selected from deuterium, -F, -Cl, -Br, -I, a hydroxyl group, a cyano group, a nitro group, an amidino group, a hydrazino group, a hydrazono group, a C₁-C₂₀ alkyl group, and a C₁-C₂₀ alkoxy group;

35 a cyclopentyl group, a cyclohexyl group, a phenyl group, a naphthyl group, a pyridinyl group, a pyrimidinyl group, a pyrazinyl group, a pyridazinyl group, a pyrrolyl group, an indolyl group, an isoindolyl group, an indazolyl group, a quinolinyl group, an isoquinolinyl group, a quinoxalyl group, a quinazolyl group, a cinnolinyl group, and a triazinyl group; and

40 a cyclopentyl group, a cyclohexyl group, a phenyl group, a naphthyl group, a pyridinyl group, a pyrimidinyl group, a pyrazinyl group, a pyridazinyl group, an indolyl group, an isoindolyl group, an indazolyl group, a quinolinyl group, an isoquinolinyl group, a quinoxalyl group, a quinazolyl group, a cinnolinyl group, and a triazinyl group, each substituted with at least one selected from deuterium, -F, -Cl, -Br, -I, a hydroxyl group, a cyano group, a nitro group, an amidino group, a hydrazino group, a hydrazono group, a C₁-C₂₀ alkyl group, a C₁-C₂₀ alkoxy group, a cyclopentyl group, a cyclohexyl group, a phenyl group, a naphthyl group, a pyridinyl group, a pyrimidinyl group, a pyrazinyl group, a pyridazinyl group, an indolyl group, an isoindolyl group, an indazolyl group, a quinolinyl group, an isoquinolinyl group, a quinoxalyl group, a quinazolyl group, a cinnolinyl group, and a triazinyl group, -Si(Q₃₁)(Q₃₂)(Q₃₃), -N(Q₃₁)(Q₃₂), -B(Q₃₁)(Q₃₂), -C(=O)(Q₃₁), -S(=O)₂(Q₃₁), and -P(=O)(Q₃₁)(Q₃₂); and

45 -Si(Q₁)(Q₂)(Q₃), -N(Q₁)(Q₂), -B(Q₁)(Q₂), -C(=O)(Q₁), -S(=O)₂(Q₁), and -P(=O)(Q₁)(Q₂), and Q₁ to Q₃ and Q₃₁ to Q₃₃ are each independently selected from hydrogen, deuterium, -F, -Cl, -Br, -I, a cyano group, a C₁-C₂₀ alkyl group, a C₂-C₂₀ alkenyl group, a C₂-C₂₀ alkynyl group, a C₁-C₂₀ alkoxy group, a C₃-C₁₀ cycloalkyl group, a C₁-C₁₀ heterocycloalkyl group, a C₃-C₁₀ cycloalkenyl group, a C₁-C₁₀ heterocycloalkenyl group, a C₆-C₂₀ aryl group, a C₁-C₂₀ heteroaryl group, a monovalent non-aromatic condensed polycyclic group, and a monovalent non-aromatic condensed heteropolycyclic group.

17. An organometallic compound according to claim 7, wherein:

55 Formula 1 is represented by Formula 1-1 or 1-2:

Formula 1-1

Formula 1-2

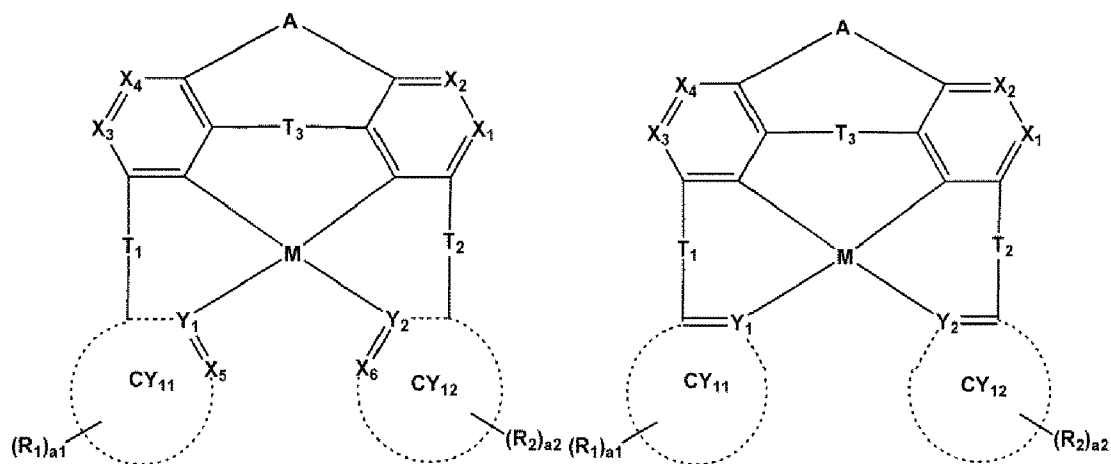

wherein, in Formulae 1-1 and 1-2,
 M, A, X₁ to X₄, T₁ to T₃, Y₁, Y₂, R₁, R₂, a₁, and a₂ are respectively the same as defined in claim 7,
 CY₁₁ and CY₁₂ are respectively the same as defined in connection with CY₁ and CY₂ in claim 7, and
 X₅ is C(R₁₅) or N, and X₆ is C(R₁₆) or N.

18. An organometallic compound according to claim 17, wherein:

X₁ to X₄ is each CH,
 T₃ is a single bond,
 A is selected from O, S, N(R₃), C(R₃)(R₄), and Si(R₃)(R₄),
 R₃ and R₄ are each independently selected from:

hydrogen, deuterium, -F, -Cl, -Br, -I, a hydroxyl group, a cyano group, a C₁-C₂₀ alkyl group, a C₁-C₂₀ alkoxy group, a phenyl group, a naphthyl group, a pyridinyl group, a pyrimidinyl group, a pyrazinyl group, a pyridazinyl group; and
 a phenyl group, a naphthyl group, a pyridinyl group, a pyrimidinyl group, a pyrazinyl group, and a pyridazinyl group, each substituted with at least one selected from deuterium, -F, -Cl, -Br, -I, a hydroxyl group, a cyano group, a C₁-C₂₀ alkyl group, and a C₁-C₂₀ alkoxy group.

19. An organometallic compound according to any one of claims 7 to 18, wherein:
 Formula 1 is represented by one of Formulae 1-1a to 1-1d:

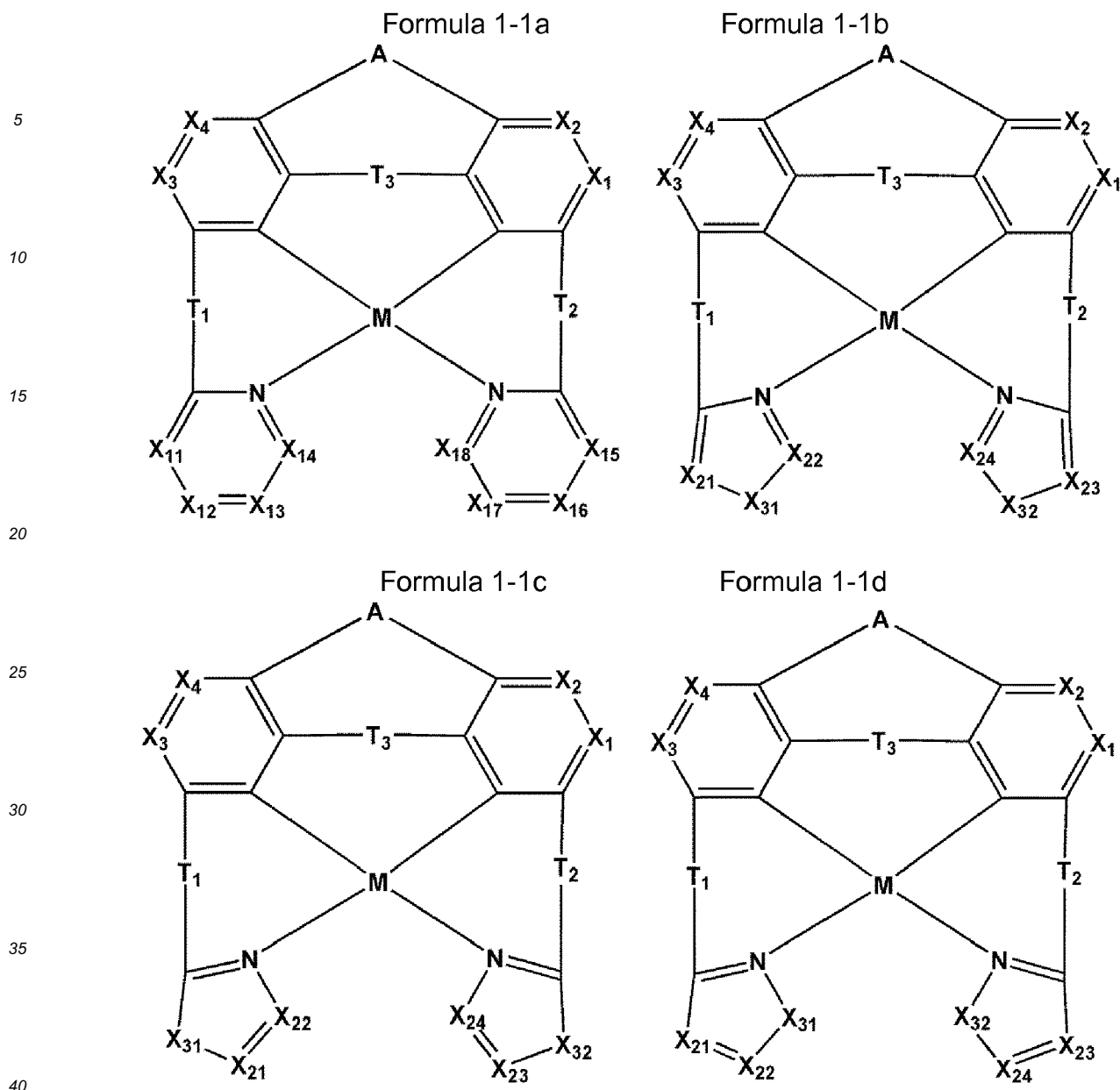

wherein, in Formulae 1-1a to 1-1d,

M, A, X₁ to X₄, and T₁ to T₃ are respectively the same as defined in claim 1,

X₁₁ is C(R_{11a}) or N, X₁₂ is C(R_{12a}) or N, X₁₃ is C(R_{13a}) or N, X₁₄ is C(R_{14a}) or N, X₁₅ is C(R_{15a}) or N, X₁₆ is C(R_{16a}) or N, X₁₇ is C(R_{17a}) or N, and X₁₈ is C(R_{18a}) or N,

R_{11a} to R_{14a} are respectively the same as defined in connection with R₁ in claim 1, and R_{15a} to R_{18a} are respectively the same as defined in connection with R₂ in claim 7,

two neighboring groups selected from R_{11a} to R_{18a} are optionally linked to form a substituted or unsubstituted C₅-C₆₀ carbocyclic group or a substituted or unsubstituted C₁-C₆₀ heterocyclic group,

X₂₁ is C(R_{21a}) or N, X₂₂ is C(R_{22a}) or N, X₂₃ is C(R_{23a}) or N, and X₂₄ is C(R_{24a}) or N,

X₃₁ is C(R_{31a})(R_{31b}) or N(R_{31a}), and X₃₂ is C(R_{32a})(R_{32b}) or N(R_{32a}),

R_{21a}, R_{22a}, R_{31a}, and R_{31b} are respectively the same as defined in connection with R₁ in claim 7, and R_{23a}, R_{24a}, R_{32a}, and R_{32b} are respectively the same as defined in connection with R₂ in claim 7, and

two neighboring groups selected from R_{21a} to R_{24a}, R_{31a}, R_{31b}, R_{32a}, and R_{32b} are optionally linked to form a substituted or unsubstituted C₅-C₆₀ carbocyclic group or a substituted or unsubstituted C₁-C₆₀ heterocyclic group.

20. An organometallic compound according to claim 7, wherein:

the compound represented by Formula 1 is selected from Compounds 1 to 107:

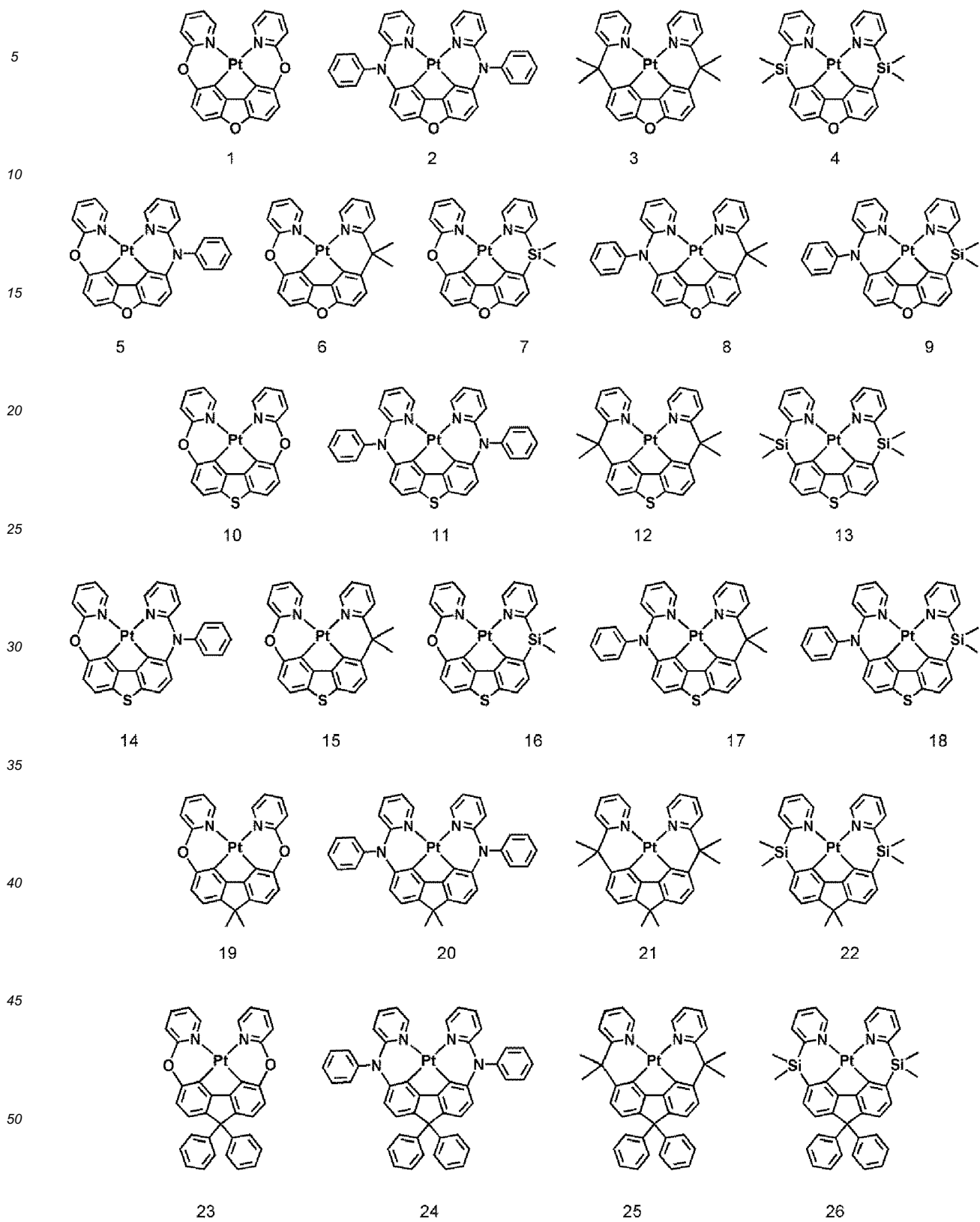

5

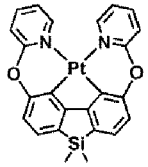

27

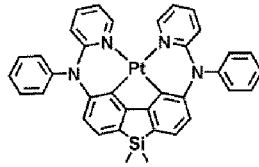

28

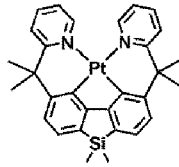

29

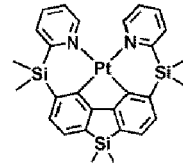

30

10

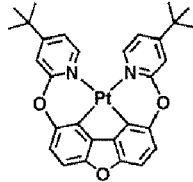

31

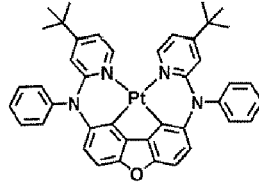

32

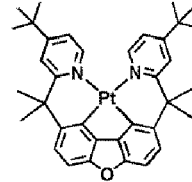

33

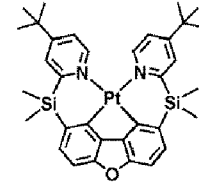

34

15

20

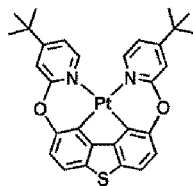

35

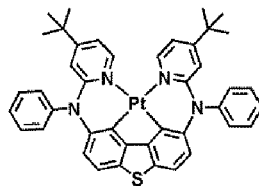

36

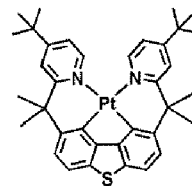

37

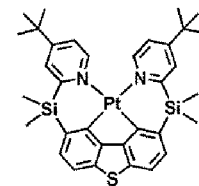

38

25

30

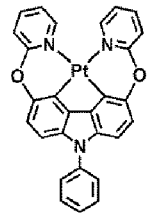

39

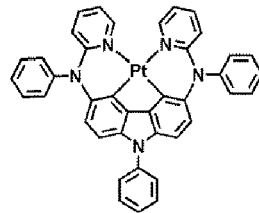

40

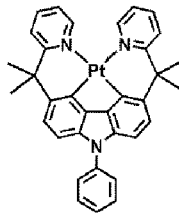

41

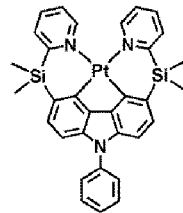

42

35

40

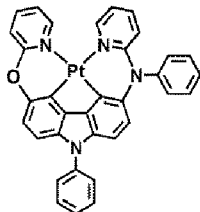

43

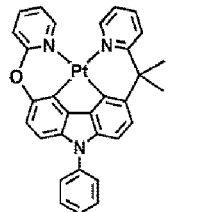

44

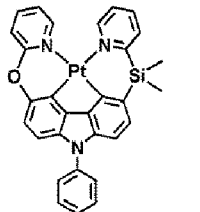

45

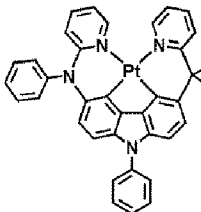

46

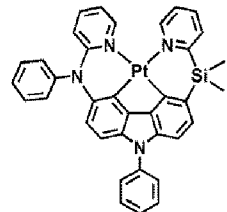

47

45

50

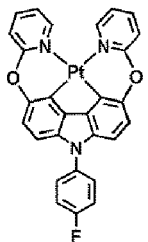

48

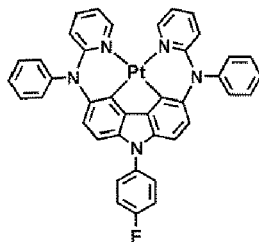

49

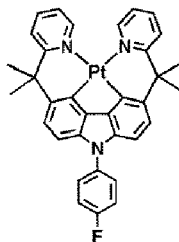

50

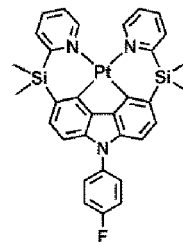

51

55

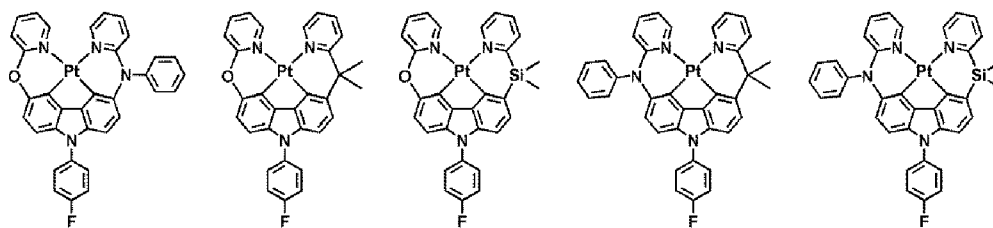

52

53

54

55

56

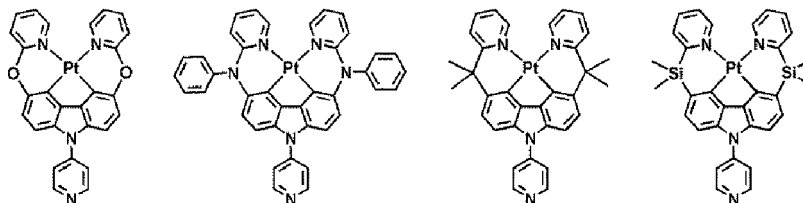

57

58

59

60

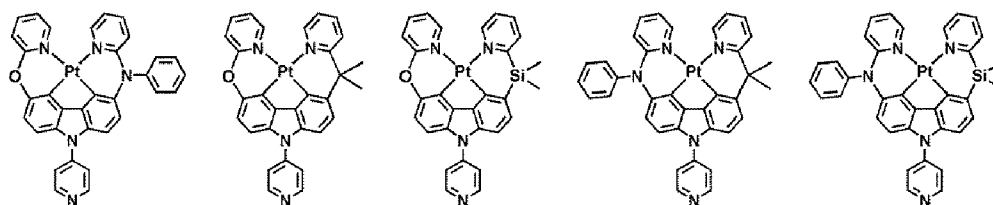

61

62

63

64

65

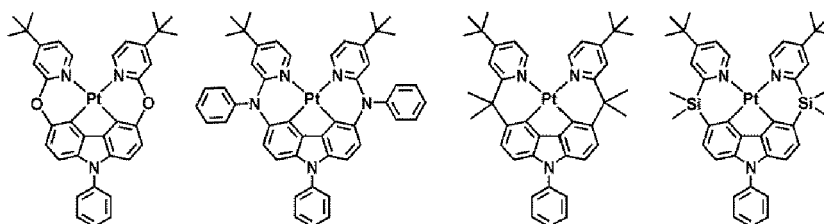

66

67

68

69

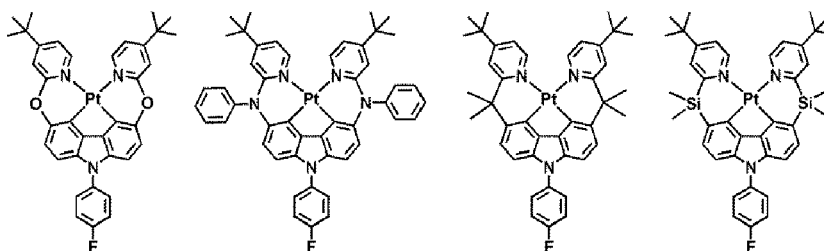

70

71

72

73

5

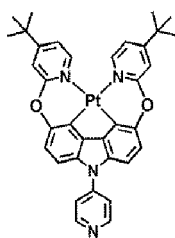

74

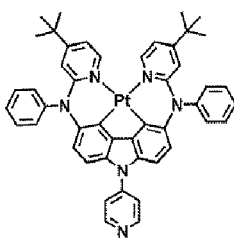

75

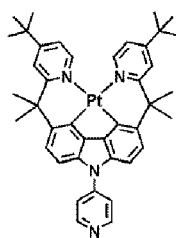

76

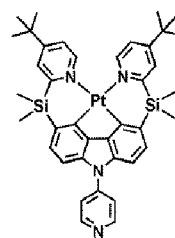

77

10

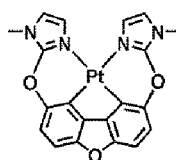

78

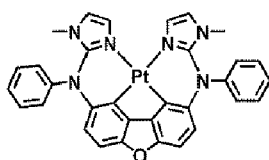

79

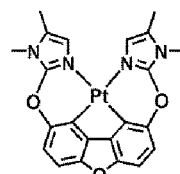

80

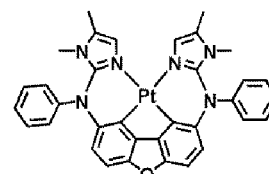

81

15

20

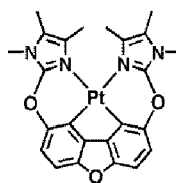

82

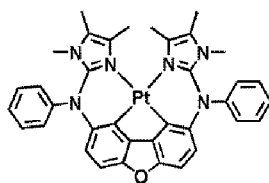

83

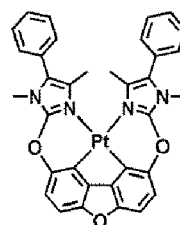

84

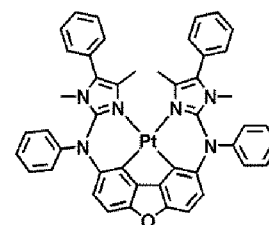

85

25

30

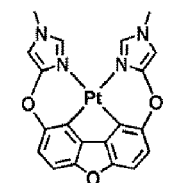

86

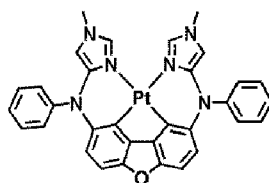

87

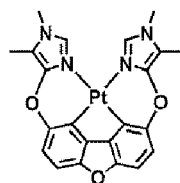

88

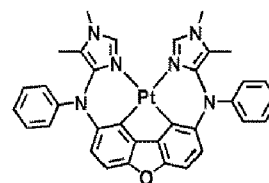

89

35

40

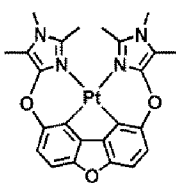

90

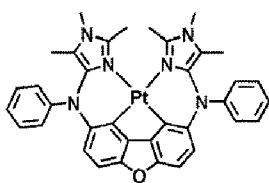

91

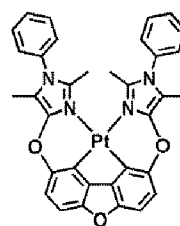

92

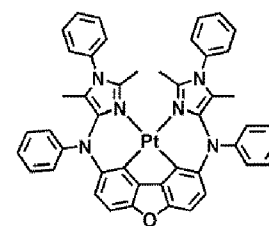

93

45

50

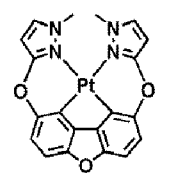

94

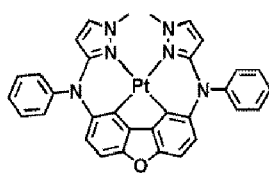

95

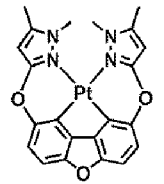

96

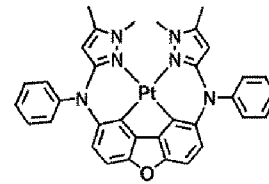

97

55

5

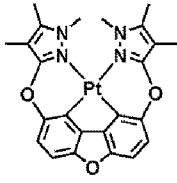

98

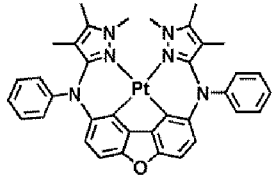

99

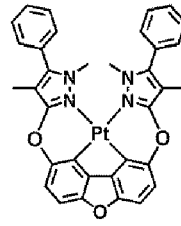

100

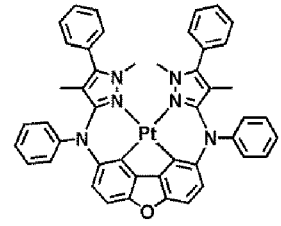

101

10

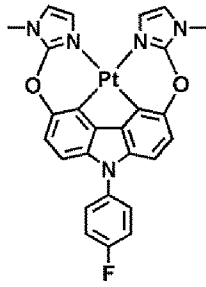

102

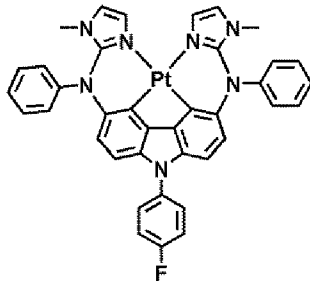

103

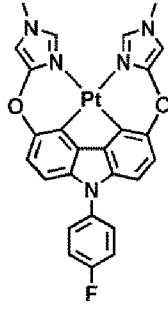

104

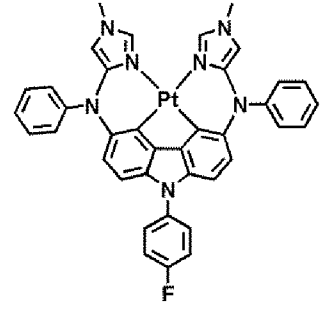

105

20

25

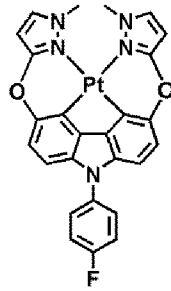

106

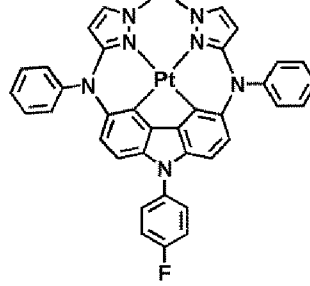

107

30

35

40

45

50

55

FIG. 1

10

190
150
110

FIG. 2

20

190
150
110
210

FIG. 3

30

220
190
150
110

FIG. 4

40

220
190
150
110
210



EUROPEAN SEARCH REPORT

Application Number
EP 19 15 4092

5

10

15

20

25

30

35

40

45

50

55

DOCUMENTS CONSIDERED TO BE RELEVANT			
Category	Citation of document with indication, where appropriate, of relevant passages	Relevant to claim	CLASSIFICATION OF THE APPLICATION (IPC)
X	WEI K J ET AL: "Self-assembly of a 3-D porous solid based on a 1-D Ag(I) coordination polymer", INORGANIC CHEMISTRY COMMUNICATIONS, ELSEVIER, AMSTERDAM, NL, vol. 9, no. 9, 1 September 2006 (2006-09-01), pages 926-930, XP028039804, ISSN: 1387-7003, DOI: 10.1016/J.INOCHE.2006.05.027 [retrieved on 2006-09-01]	7,17-19	INV. H01L51/54 C07F15/00
A	* page 926 - page 929; figures 1-4 * -----	1-6,8-16	
A	WO 2012/079741 A1 (MERCK PATENT GMBH [DE]; KUNZ DORIS [DE]; GIERZ VERENA [DE]) 21 June 2012 (2012-06-21) * page 29 - page 32 * -----	1-20	
A	US 2016/028029 A1 (LI JIAN [US] ET AL) 28 January 2016 (2016-01-28) * paragraph [0151] - paragraph [0161] * -----	1-20	TECHNICAL FIELDS SEARCHED (IPC)
A	WO 2010/118026 A2 (UNIV ARIZONA [US]; LI JIAN [US]; WANG ZIXING [US]; TURNER ERIC [US]) 14 October 2010 (2010-10-14) * claims 1-21 * -----	1-20	C07F H01L
The present search report has been drawn up for all claims			
Place of search The Hague		Date of completion of the search 12 August 2019	Examiner Königstein, C
CATEGORY OF CITED DOCUMENTS			
X : particularly relevant if taken alone Y : particularly relevant if combined with another document of the same category A : technological background O : non-written disclosure P : intermediate document		T : theory or principle underlying the invention E : earlier patent document, but published on, or after the filing date D : document cited in the application L : document cited for other reasons & : member of the same patent family, corresponding document	

1
EPO FORM 1503 03 82 (P04C01)

ANNEX TO THE EUROPEAN SEARCH REPORT
ON EUROPEAN PATENT APPLICATION NO.

EP 19 15 4092

5 This annex lists the patent family members relating to the patent documents cited in the above-mentioned European search report.
The members are as contained in the European Patent Office EDP file on
The European Patent Office is in no way liable for these particulars which are merely given for the purpose of information.

12-08-2019

Patent document cited in search report	Publication date	Patent family member(s)	Publication date
WO 2012079741 A1	21-06-2012	CN 103261210 A	21-08-2013
		DE 102011106849 A1	21-06-2012
		DE 112011104390 A5	12-09-2013
		JP 6261982 B2	17-01-2018
		JP 2014506241 A	13-03-2014
		KR 20140145934 A	24-12-2014
		US 2013284977 A1	31-10-2013
		WO 2012079741 A1	21-06-2012
US 2016028029 A1	28-01-2016	JP 2016034935 A	17-03-2016
		US 2016028029 A1	28-01-2016
		US 2017125708 A1	04-05-2017
		US 2018277777 A1	27-09-2018
WO 2010118026 A2	14-10-2010	CN 102449108 A	09-05-2012
		EP 2417217 A2	15-02-2012
		JP 5604505 B2	08-10-2014
		JP 2012522843 A	27-09-2012
		JP 2014221807 A	27-11-2014
		KR 20120015303 A	21-02-2012
		KR 20170122295 A	03-11-2017
		US 2012095232 A1	19-04-2012
		US 2015318500 A1	05-11-2015
WO 2010118026 A2	14-10-2010		

专利名称(译)	有机金属化合物，包括该有机金属化合物的有机发光装置以及包括该有机发光装置的有机发光装置		
公开(公告)号	EP3544075A1	公开(公告)日	2019-09-25
申请号	EP2019154092	申请日	2019-01-29
[标]申请(专利权)人(译)	三星显示有限公司		
申请(专利权)人(译)	三星DISPLAY CO. , LTD.		
当前申请(专利权)人(译)	三星DISPLAY CO. , LTD.		
[标]发明人	SIM MUNKI KO SOOBYUNG KIM SUNGBUM PARK JUNHA AHN HEECHOON LEE HYOYOUNG JEON MINA JUN MIEUN HAN JUNGHOON KIM YOUNGKOOK HWANG SEOKHWAN		
发明人	SIM, MUNKI KO, SOOBYUNG KIM, SUNGBUM PARK, JUNHA AHN, HEECHOON LEE, HYOYOUNG JEON, MINA JUN, MIEUN HAN, JUNGHOON KIM, YOUNGKOOK HWANG, SEOKHWAN		
IPC分类号	H01L51/54 C07F15/00		
CPC分类号	C07F15/0086 C09K11/06 C09K2211/185 H01L51/0087 H01L51/0094 H01L51/50 H01L51/5016 H01L27/3244 H01L51/5056 H01L51/5072 H01L51/5088 H01L51/5092 H01L51/5096		
优先权	1020180033483 2018-03-22 KR		
外部链接	Espacenet		

摘要(译)

提供一种有机金属化合物，包括该有机金属化合物的有机发光器件以及包括该有机发光器件的电子设备。该有机发光装置包括：第一电极；以及第二电极。面对第一电极的第二电极；在第一电极和第二电极之间并包括发射层的有机层，其中有机层包括由式1表示的有机金属化合物中的至少一个。

FIG. 1

10

190
150
110